

# MANITOWOC

# 36-Foot Diameter PLATFORM-RINGER™

(U.S. and Foreign Patents Applied For.)

## SPECIFICATIONS



Counterweights partially removed  
to reveal machinery components.

# MANITOWOC 36-Foot Diameter PLATFORM-RINGER™

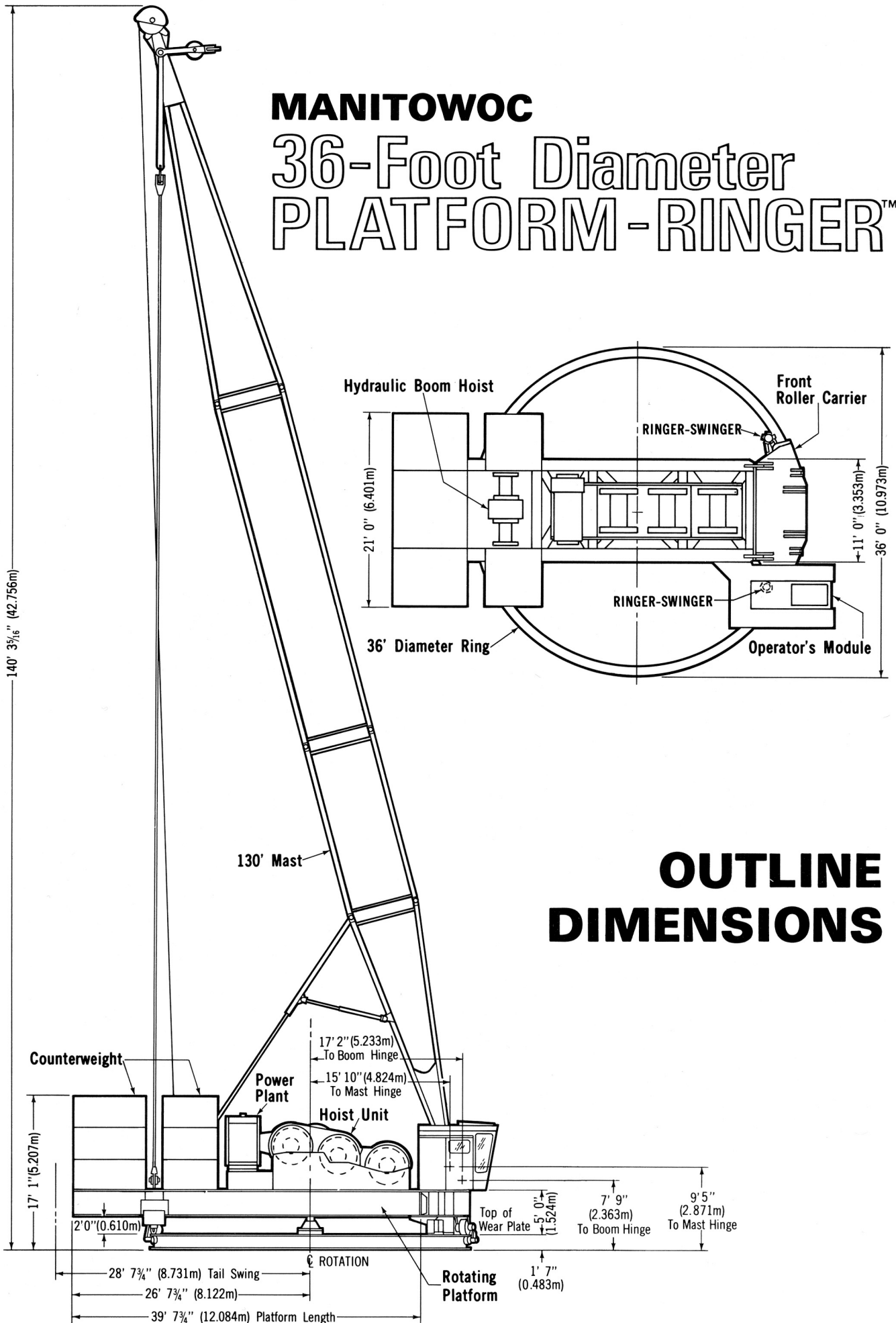

## OUTLINE DIMENSIONS

# WEIGHTS

	POUNDS*		POUNDS*
<b>36' DIAMETER RING</b> , 4 segments with wear plates . . . . .	38,610	<b>MAST AND BACKHITCH</b> , 130' No. 22A mast with pendant backhitch . . . . .	31,170
<b>FRONT ROLLER CARRIER</b> , with 4 house rollers, 2 hook rollers and mast support . . . . .	22,000	<b>OPERATOR'S MODULE</b> , complete with all operating controls and mounting bracket . . . . .	2,050
<b>ROTATING PLATFORM</b> , with 2-drum 390 Hoist and hydraulic boom hoist . . . . .	112,720	<b>BOOM NO. 27</b>	
<b>RINGER-SWINGER ATTACHMENTS</b> , 2 with positioners (each 1,500) . . . . .	3,000	<b>BOOM BUTT:</b> (less wire rope and pendants) . .	8,485
<b>REMOVABLE COUNTERWEIGHT (13-PC)</b>		<b>BOOM TOP:</b> (equipped with six sheave lower boom point) . . . . .	9,720
Rear (7 boxes, each 46,000) . . . . .	322,000	Add for upper boom point and sheave . . .	1,255
Front Left (3 boxes, each 38,000) . . . . .	114,000	Total . . . . .	10,975
Front Right (3 boxes, each 38,000) . . . . .	114,000	<b>BOOM INSERTS:</b>	
Total . . . . .	550,000	Insert — 20' (with pendants & wire rope guide) .	3,860
<b>TELESCOPIC BOOM STOPS</b> . . . . .	825	Insert — 40' (with pendants & wire rope guides) .	6,650

*\*Weights are approximate and may vary between machines as a result of design changes and component variations.*

## 36-FOOT DIAMETER RING ASSEMBLY

**RING SEGMENTS:** Fabricated, reinforced I-beam construction. Four ring segments (front, rear and two sides) are bolt-connected for fast installation and removal.

**WEAR PLATES:** Sixteen ¾" alloy steel plates cut to fit on

top of ring segments to protect them from wear. Attached to ring by retainer plates designed to clear hook roller hanger assembly.

**RING GEAR:** Sixteen segments bolt-connected to ring.

## ROTATING STRUCTURE

**ROTATING PLATFORM:** Fabricated deep box section side rails with lattice-type supports form a mounting platform for machinery components. Catwalks and railings provided along both sides of platform. Platform can be mounted on fixed or transporter base. Base or transporter must be equipped with king pin to provide concentricity between rotating platform and 36' diameter ring.

**KING PIN:** Cast steel. Bolted to support structure with high strength bolts. Provides pivot for rotating platform. Takes horizontal load only, no uplift. Grease fittings provide lubrication to bronze bearings in platform. Support structure supplied by customer, except with transporter mounting.

**FRONT ROLLER CARRIER:** Fabricated box section construction with 4 house rollers and 2 hook rollers, all antifriction bearing mounted. Provides lugs for boom hinge pins and mast support. Pin-connected to front end of rotating platform.

**OPERATOR'S MODULE:** Steel construction, independently mounted on boom carrier, fully enclosed and insulated. Includes operating controls for load hoist, boom hoist and swing; safety glass windows, cab heater, wind-

shield wiper, horn and defogging fan.

**COUNTERWEIGHT TRAY:** Rotating platform extends beyond 36' diameter ring to form center section of counterweight tray. Two side wings pin-connected to center section complete rear counterweight tray which supports 322,000 pounds of counterweight. Two additional side wings, pin-connected to rotating platform on either side of boom hoist, each support 114,000 pounds of counterweight.

**COUNTERWEIGHT ROLLERS:** Two sets of dual equalized support rollers and two hook rollers mounted under center section of rear counterweight tray are antifriction bearing mounted.

**RINGER COUNTERWEIGHTS:** 550,000 pounds. Optional interlocking steel boxes filled with scrapcrete (consisting of 7 boxes weighing 46,000 pounds each and 6 boxes weighing 38,000 pounds each). Note: counterweights can be supplied at job site in most readily available form such as cast concrete, steel plate or billets. Certification of weights is recommended to assure accuracy of counterweight.

# MACHINERY COMPONENTS

**LOAD HOIST:** VICON® (Variable Independent CONTROL) controlled 390 Hoist with power plant for load and whip lines. Available in either 2 or 3 drum models for versatility in meeting specific application requirements. Hoist includes VICON power load lowering, radiator, engine shroud, fully enclosed gears and drive chains, anti-friction bearing drum journals, electric starting, instrument panel and air controls in operator's module. Drums 19" in diameter x 37¼" wide, equipped with ratchet and pawl. Optional grooved laggings available. Dual, air actuated drum brakes are spring set, air released, air applied. Single, air actuated drum clutches.

**INDEPENDENT BOOM HOIST:** Dual drums with grooved laggings driven by bronze worm and gear through planetary gear reduction. All rotating shafts antifriction bearing mounted. Boom hoist powered by variable displacement hydraulic motor providing full range speed control. Boom hoist brake, external contracting band-type, spring applied, air released. Auxiliary brake, external contracting band-type, manually applied from operator's module. Ratchet mounted to worm gear; pawl gravity engaged, air released. Ratchet and pawl mounted inside gear housing. Boom hoist mounted on rear of rotating platform.

**POWER PLANTS:** See page 5.

## THE RINGER-SWINGER™

The swing function for the 36' diameter PLATFORM-RINGER is performed by Manitowoc's exclusive, patented RINGER-SWINGER system. This fully modulated, hydraulically powered system provides swing acceleration or deceleration in either direction. Operation is controlled by a single lever and full, free-float exists when lever is in neutral position.

The system utilizes two RINGER-SWINGER units, one mounted on either side of the front roller carrier. A hydraulic motor powers a direct drive pinion which is held in constant contact against an internal ring gear by hydraulic and spring positioners. A drive pinion flange and gear segment skirt maintains pitch control between pinion and ring gear.

The number of RINGER-SWINGER assemblies required for a project, such as barge-mounting, depends upon specific lifting and swinging requirements. Two RINGER-SWINGERS are standard equipment on each 36' diameter PLATFORM-RINGER and additional RINGER-SWINGERS are optional. Consult factory for specific information.

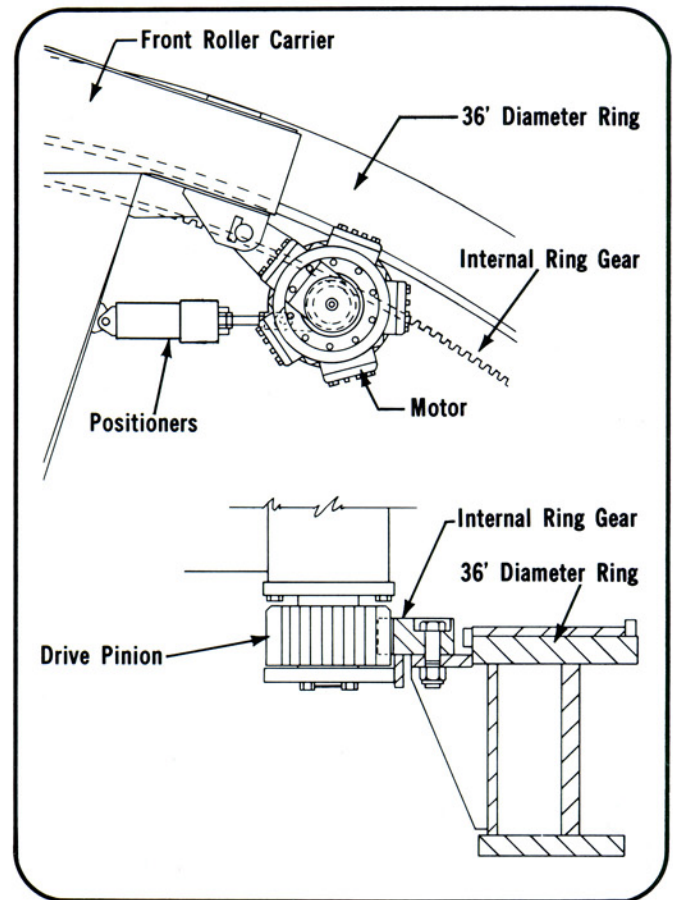
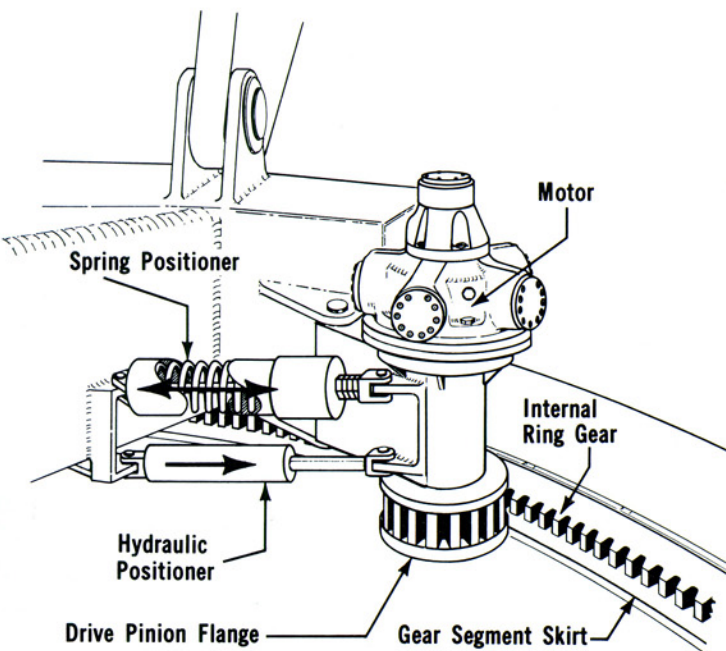

# POWER PLANT OPTIONS

	Cylinder	Bore	Stroke	Cubic Inch Displacement	Net HP @ RPM (at flywheel)
Cummins KT-1150-C450	6	6.25"	6.25"	1,150	450 @ 2,000
Caterpillar 3408 PC-TA	8	5.40"	6.00"	1,099	460 @ 2,000
Caterpillar D346	8	5.25"	6.50"	1,191	535 @ 2,000
G.M. 12V-71N	12	4.25"	5.00"	852	410 @ 2,000
Fuel Tank Capacity: 200 Gallons.					

# DRUMS AND LAGGINGS

Model 390 Hoist

Application	Drum	Diameter	Drum Width	Wire Rope Size	Spooling Capacity		
					First Layer	Layers	Max. Capacity
<b>2-DRUM HOIST</b>							
LIFTCRANE Hoist Whip	Front	19.0"	37.25"	1 $\frac{1}{8}$ "	161'	7	1,505'
	Rear	19.0"	37.25"	1 $\frac{1}{8}$ "	161'	7	1,505'
<b>OPTIONAL 3-DRUM HOIST</b>							
LIFTCRANE Hoist Whip	2-Front	19.0"	37.25"	1 $\frac{1}{8}$ "	161'	7	3,010'
	1-Rear	19.0"	37.25"	1 $\frac{1}{8}$ "	161'	7	1,505'

# FRONT END EQUIPMENT

**NO. 27 BOOM:** 40' boom butt, 40' open throat top, 20' and 40' inserts. All welded construction. Rectangular boom with inverted angle chords and tubular lagings. Chords are 100,000 PSI yield steel. Lower boom point equipped with six 32" OD antifriction bearing mounted sheaves. Basic boom length 140'; maximum boom length 340'.

**FIXED MAST:** Consists of 130' No. 22A boom with open throat top. Mast is pin-connected to mast support on front roller carrier.

**BACKSTAY STRUT:** Two-piece, box section construction. Supports mast when boom hoist lines are slack.

**MAST BACKSTAY PENDANTS:** Four 2" swaged structural strand pendants.

**BOOM RIGGING:** Eight-part line reeved between fixed mast and boom equalizer. Controls boom angle by single line continuously reeved from dual boom hoist drums which power boom up and down. Two pair of 1 $\frac{1}{8}$ " pendants connect equalizer to boom point.

**EQUALIZER:** Steel fabrication. Four vertical sheaves antifriction bearing mounted.

**WIRE ROPE GUIDE:** Mounted on top side of boom. Two sheaves bronze bearing mounted.

**WIRE ROPE ROLLER GUIDE:** Mounted on top side of boom. Induction hardened tubing. Antifriction bearing mounted.

**UPPER BOOM POINT:** Optional. Pin-connected to open throat top. Single or double 36" OD sheaves available, both antifriction bearing mounted.

**4 $\frac{1}{2}$ ° OFFSET BOOM TOP:** Optional. Permits greater clearance between load and boom. Standard No. 27 boom converted by adapter links at upper boom joint.

**FOR CAPACITY CHARTS AND INFORMATION, CONSULT FACTORY.**

**NO. 122A JIB:** Optional. 28-ton maximum capacity. 40' length extendible to 50' with 10' insert. Jib angle adjustable to 3, 10, and 20 degrees. Top section equipped with 32" roller bearing sheave, wire rope guide and anchor for two-part line. Jib attaches to lower boom point.

**CONSULT JIB LIFTING CAPACITY CHARTS FOR SPECIFIC CAPACITY WHEN USED ON VARIOUS BOOM LENGTHS.**

**NO. 123 JIB:** Optional. 20-ton capacity. 30' length extendible to 60' with 10' inserts. Jib angle adjustable to 0, 10, and 20 degrees. Top section equipped with 24" roller bearing sheave, wire rope guide and anchor for two-part line. Jib adapter required to mount No. 123 jib on No. 27 boom.

**CONSULT JIB LIFTING CAPACITY CHARTS FOR SPECIFIC CAPACITY WHEN USED ON VARIOUS BOOM LENGTHS.**

# FIXED MOUNT

Manitowoc's 36' diameter PLATFORM-RINGER is adaptable to provide high capacity lifting capability for barge, pedestal or gantry applications. The fixed mount eliminates the need for ring side beams. Only a king pin support is required.

The 36' diameter ring can be directly mounted to top of its support structure and secured by a clamp arrangement. The ring can also be supported on blocking or steel pedestals located on 4' centers under the ring perimeter and at its four segment joints.

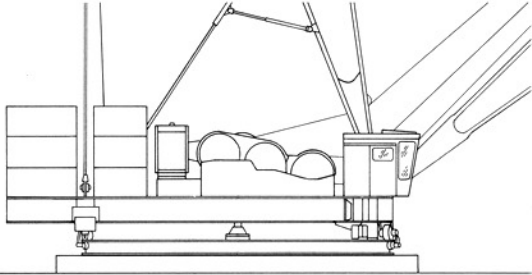

**PEDESTAL MOUNT**

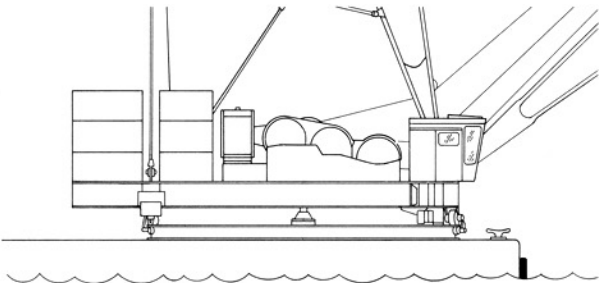

**BARGE MOUNT**

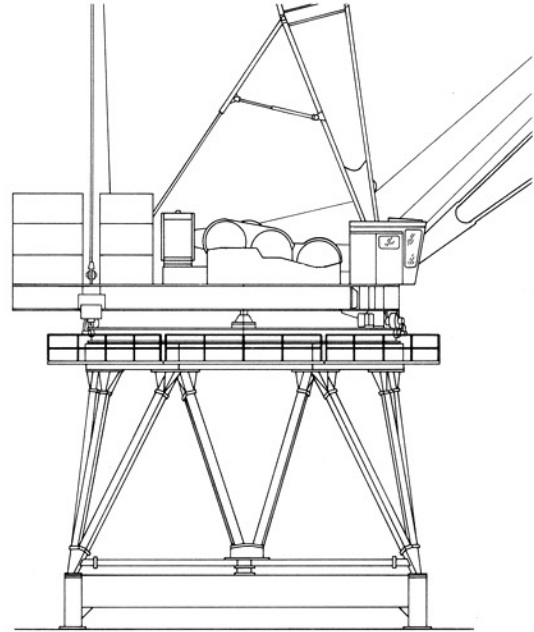

**GANTRY MOUNT**

# MOBILE MOUNT

For even greater versatility, Manitowoc's 36' diameter PLATFORM-RINGER can be crawler-transporter mounted to provide the mobility needed to move the PLATFORM-RINGER from lift to lift. The crawler-transporter can then be removed and utilized as a high capacity load transporter while the PLATFORM-RINGER remains available for lift work.

This method of mounting requires two side beams and a king pin assembly which are bolt-connected to the transporter carbody. The ring is supported in a conventional manner using blocking or Manitowoc's Screw-Jack support system.

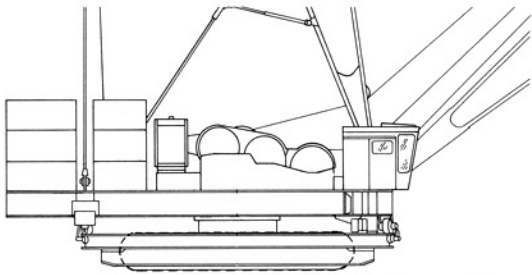

**CRAWLER-TRANSPORTER**

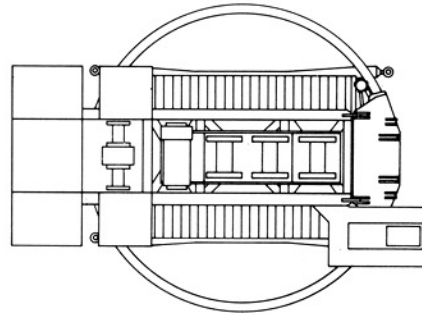

*Because of a program of continuing improvements, Manitowoc Engineering Co. reserves the right to change this description at any time, without notice.*

**MANITOWOC ENGINEERING CO.**  
(A division of The Manitowoc Company, Inc.)  
Manitowoc, Wisconsin 54220

