

GRUA TORRE / TOWER CRANE

GRUE A TOUR / БАШЕННЫЙ КРАН /

KULE VINÇ / رافعة برجية

J380PA



EN 14439
C25

UNE-EN-ISO 9001

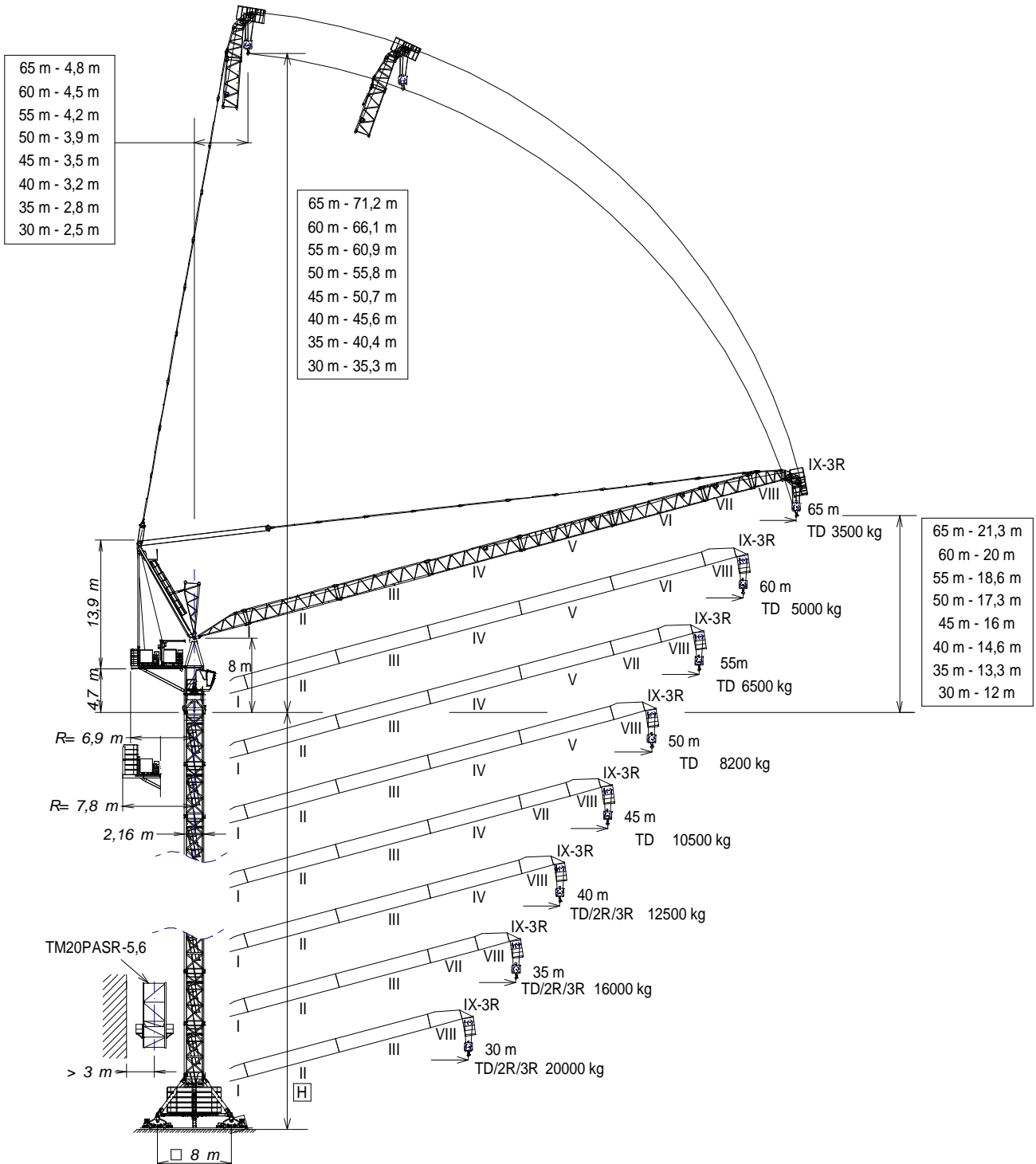

<p>H = Máxima altura de torre sin arriostrar (m). Maximum tower height without fastening (m). Hauteur maximale de tour sans ancrage (m). Максимальная высота башни без крепления (м). Desteksiz maksimum kule yüksekliği (m). أقصى ارتفاع للبرج بدون ربط (م)</p>	*Tramo pluma I / Jib setion I -----	206.40.000	
	*Tramo pluma II / Jib setion II -----	206.41.000	BSR18-20-5,6H ----- 166.20.500
	*Tramo pluma III / Jib setion III -----	206.42.000	ASR20 ----- 160.21.200
	*Tramo pluma IV / Jib setion IV -----	206.43.000	TSR20 ----- 153.31.800
	*Tramo pluma V / Jib setion V -----	206.44.000	TSR20-5,6 ----- 204.31.000
	*Tramo pluma VI / Jib setion VI -----	206.45.000	TM20PASR-5,6 ----- 206.35.000
	*Tramo pluma VII / Jib setion VII -----	206.46.000	ABH100B ----- 204.23.000
	*Tramo pluma VIII / Jib setion VIII -----	206.47.000	ABH100H ----- 156.23.500
	*Tramo pluma IX-3R / Jib setion IX-3R -----	206.49.000	

* Tramo pluma / Jib section / Tronçon de flèche / Секция стрелы / Bom bölümü / أجزاء الذراع



JASO EQUIPOS DE OBRAS Y CONSTRUCCIONES, S.L.



FEM 1005 - C25

Reservado el derecho a modificaciones sin previo aviso. Declinamos toda responsabilidad derivada de la información proporcionada / Subject to modification, without previous warning. This information is supplied without liability / L'entreprise se réserve le droit de procéder à des modifications sans préavis. Nous déclinons toute responsabilité quant aux informations fournies / Мы оставляем за собой право на внесение изменений без предварительного уведомления. Мы снимаем с себя любую ответственность в отношении предоставленной информации / Önceden bildirilmeksizin değiştirilme hakkı saklıdır. Verilen bilgiler için hiçbir sorumluluk kabul etmemekteyiz / حقوق التغيير محفوظة دون إشعار مسبق. دون أدنى مسؤولية عن المعلومات المقدمة

Fecha / Date: 10-09-2014

TD

(H) TRASLACIÓN / TRAVELLING /

TRASLATION / ПЕРЕМЕЩЕНИЕ / RAY YÜRÜYÜŞLÜ / متحركة

(H) ESTACIONARIA / STATIONARY /

STATIONAIRE / СТАЦИОНАРНОЕ СОСТОЯНИЕ / SABIT / ثابتة

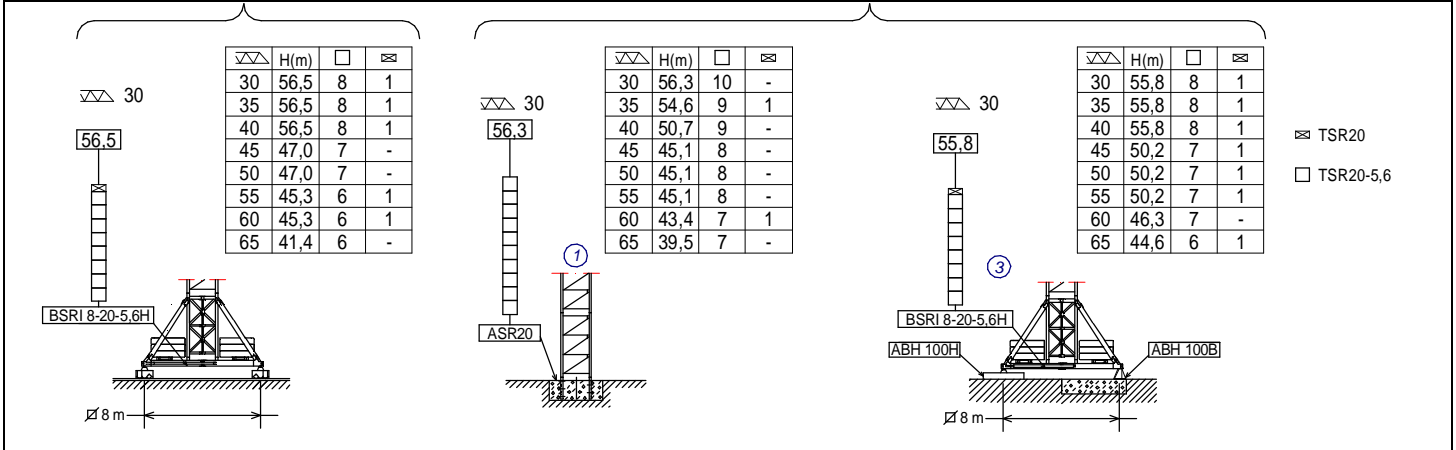

TD / 2R / 3R

(H) TRASLACIÓN / TRAVELLING /

TRASLATION / ПЕРЕМЕЩЕНИЕ / RAY YÜRÜYÜŞLÜ / متحركة

(H) ESTACIONARIA / STATIONARY /

STATIONAIRE / СТАЦИОНАРНОЕ СОСТОЯНИЕ / SABIT / ثابتة

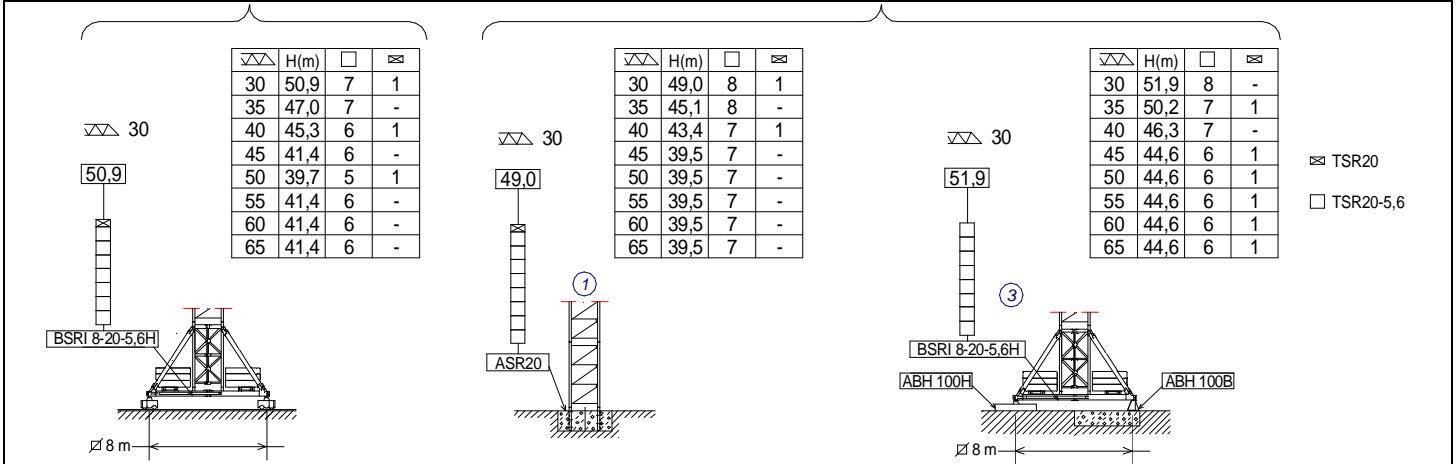

TREPADO / CLIMBING / TÉLESCOPAGE / ЛЕСТНИЦА / TIRMANMA / التسلق

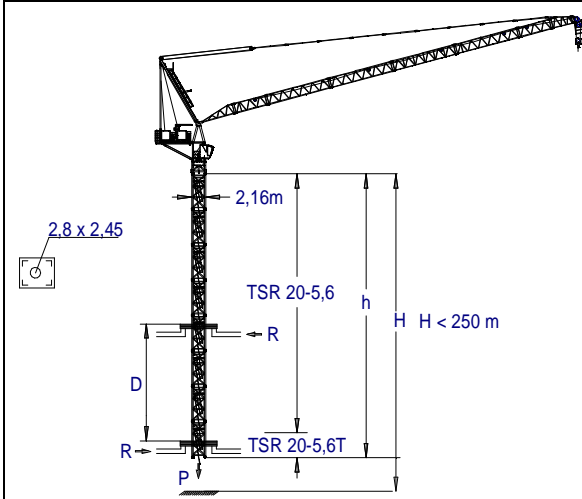

h_{max}: TSR20-5,6T + 6xTSR20-5,6

50 m.	36 t	▶	■
h (m)	39,2		
D (m)	18,3 - 19		
P (KN)	1786	1426	
R _{max} (KN)	375	495	

TSR20-5,6T: 204.31.700

i Trepado interno / Internal climbing. / Télescopage intérieur / Внутренняя лестница / Bina içi tirmanma / التسلق الداخلي



Viento fuera de servicio / Out of service wind / Vitesse du vent hors service / Ветровая нагрузка в покое / Rüzgar devre dışı / الريح خارج الخدمة

i Consultar / Consult / Nous consulter / Консультируйтесь / Danışınız / الرجوع إلى

▶ En servicio / In service / En service / В работе / Devrede / في الخدمة

■ Fuera de servicio / Out of service / Hors service / В покое / Devre dışı / خارج الخدمة



JASO EQUIPOS DE OBRAS Y CONSTRUCCIONES, S.L.















FEM 1005 – C25

Reservado el derecho a modificaciones sin previo aviso. Declinamos toda responsabilidad derivada de la información proporcionada / Subject to modification, without previous warning. This information is supplied without liability / L'entreprise se réserve le droit de procéder à des modifications sans préavis. Nous déclinons toute responsabilité quant aux informations fournies / Мы оставляем за собой право на внесение изменений без предварительного уведомления. Мы снимаем с себя любую ответственность в отношении предоставленной информации / Önceden bildirilmeksizin değiştirilme hakkı saklıdır. Verilen bilgiler için hiçbir sorumluluk kabul etmemekteyiz / حقوق التغيير محفوظة دون إشعار مسبق. دون أدنى مسؤولية عن المعلومات المقدمة

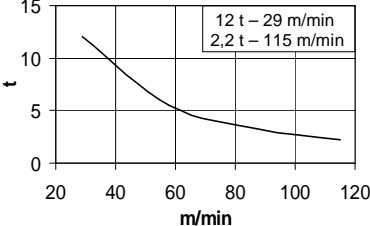
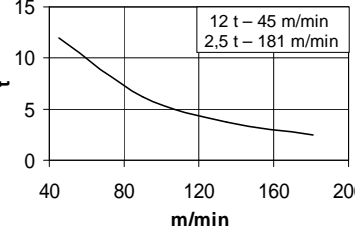
TD (t)									TD 12t @ (m)
PLUMA JIB	Alcance del gancho [m] / Hook reach [m] / Portée du crochet (m) / Радиус действия крюка (m) / Kancanın yüksekliği (m) / مدى الخطاف								
	65	60	55	50	45	40	35	30	
65 m	3,5	4,7	6,0	7,7	9,6	12,0	12,0	12,0	40,0
60 m	-	5,0	6,4	8,0	9,9	12,0	12,0	12,0	40,6
55 m	-	-	6,5	8,1	10,0	12,0	12,0	12,0	40,8
50 m	-	-	-	8,2	10,1	12,0	12,0	12,0	40,9
45 m	-	-	-	-	10,5	12,0	12,0	12,0	41,7
40 m	-	-	-	-	-	12,0	12,0	12,0	40,0
35 m	-	-	-	-	-	-	12,0	12,0	35,0
30 m	-	-	-	-	-	-	-	12,0	30,0

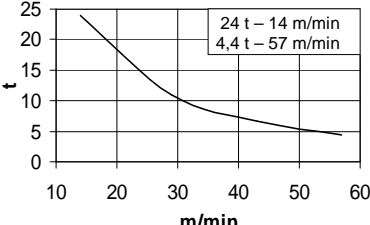
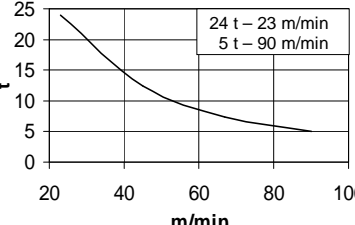

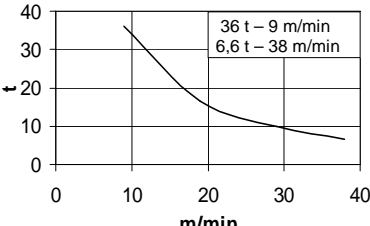
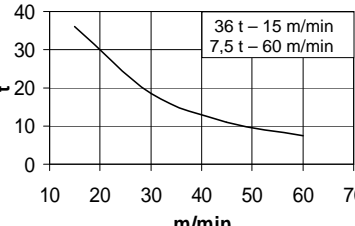
TD/2R/3R (t)												TD 12t @ (m)	2R 24t @ (m)	3R 36t @ (m)
	Alcance del gancho [m] / Hook reach [m] / Portée du crochet (m) / Радиус действия крюка (m) / Kancanın yüksekliği (m) / مدى الخطاف													
	65	60	55	50	45	40	35	30	25	20	15			
65 m	3,0	4,2	5,6	7,2	9,1	11,5	12,0	12,0	12,0	12,0	12,0	39,2		
60 m	-	4,5	5,9	7,5	9,4	11,8	14,9	19,0	24,0	24,0	24,0	39,7	25,5	
55 m	-	-	6,0	7,6	9,5	11,9	15,0	19,0	24,0	24,0	24,0	39,9	25,5	
50 m	-	-	-	7,7	9,6	12,0	15,0	19,0	24,5	32,7	36,0	40,0	25,5	18,5
45 m	-	-	-	-	10,0	12,4	15,4	19,4	24,9	33,2	36,0	40,8	25,7	18,7
40 m	-	-	-	-	-	12,5	15,5	19,5	25,0	33,3	36,0	40,0	25,7	18,7
35 m	-	-	-	-	-	-	16,0	20,0	25,4	33,5	36,0	35,0	26,1	18,8
30 m	-	-	-	-	-	-	-	20,0	25,4	33,5	36,0	30,0	26,2	18,8
Alcance del gancho [m] / Hook reach [m] / Portée du crochet (m) / Радиус действия крюка (m) / Kancanın yüksekliği (m) / مدى الخطاف												TD 9t @ (m)	2R 18t @ (m)	
	65	60	55	50	45	40	35	30	25					
65 m	3,0	4,2	5,6	7,2	9,1	11,5	14,6	18,0	18,0	45,3	30,8			
Alcance del gancho [m] / Hook reach [m] / Portée du crochet (m) / Радиус действия крюка (m) / Kancanın yüksekliği (m) / مدى الخطاف												TD 10t @ (m)	2R 20t @ (m)	3R 30t @ (m)
	55	50	45	40	35	30	25	20						
55 m	6,0	7,6	9,5	11,9	15,0	19,0	24,7	30,0	44,0	29,0	21,6			

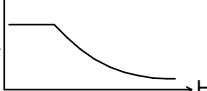
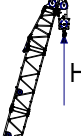

<p>*opcional *optional *en option *опция *opsiyonel *اختياري</p>												
	<p>EC88115VF 65 kW</p> 	<p>* EC150218VF 110 kW</p> 	<p>TG4025VF 4x7,5 kW</p> <p>0...25 m/min</p>	<p>OG2008VF 2x7,3 kW</p> <p>0...0,2 0,2...0,4 0,4...0,8 r/min</p> <p>sl/min</p>	<p>EP10015VF 75 kW</p> <p>1,5 min</p>	<p>TH4010 29,4 kW</p> <p>0,6 m/min</p>						
			<p> 400V 50Hz</p> <p>P_{TOTAL}(EC88115VF + OG2008VF + EP10015VF) = 154,6 kW</p> <p>P_{TOTAL}(*EC150218VF + OG2008VF + EP10015VF) = *199,6 kW</p>									
			<p>  </p> <p> $H \leq$</p> <table border="0"> <tr> <td>TD</td> <td>874m</td> </tr> <tr> <td>2R</td> <td>437m</td> </tr> <tr> <td>3R</td> <td>291m</td> </tr> </table>				TD	874m	2R	437m	3R	291m
TD	874m											
2R	437m											
3R	291m											

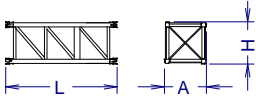
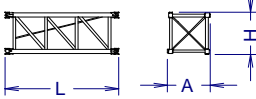
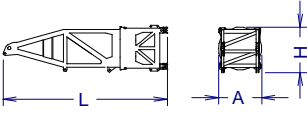
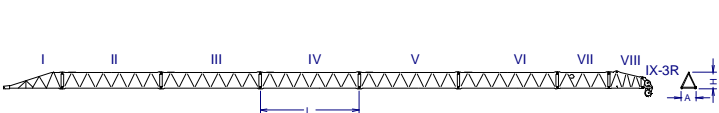
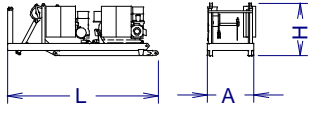
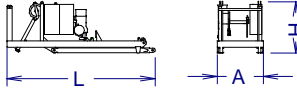
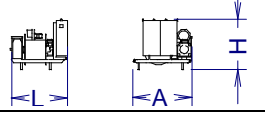
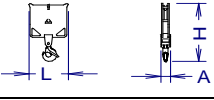
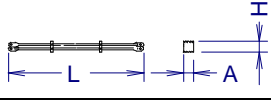
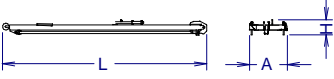
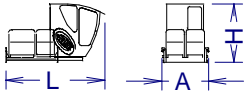
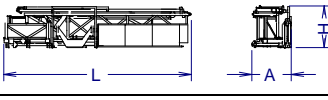
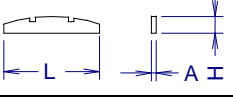

LISTA DE EMBARQUE / PACKING LIST LISTE DE COLISAGE / СПИСОК ПОСТАВКИ / ÇEKİ LİSTESİ / قائمة التحميل J380PA

DENOMINACIÓN / DENOMINATION / DÉSIGNATION / НАЗВАНИЕ / AÇIKLAMA / اسم		L [m]	A [m]	H [m]	P / W [kg]	
Torre inferior / Lower tower / Tour inférieure / Нижняя باشيا Alt kule / البرج السفلي	TSRI-20-5,6		5,990	2,257	2,257	6562
Torre / Tower / Tour باشيا / Kule / برج	TSR20 TSR20-5,6		4,260 5,990	2,251 2,257	2,251 2,257	3110 4262
Torre asiento pista, torre superior y orientación Slewing table, top tower and slewing mechanism Tour pivot + tour supérieure + mécanisme d'orientation Сиденье площадки + верхняя башня + поворотный механизм Göbek + üst kule+mekanizma برج وحدة الدوران + البرج العلوي + آلية الدوران			8,847	2,315	2,555	15680
Tramo de pluma Jib section Tronçon de flèche Секция стрелы Вот bölümü أجزاء الذراع	[I] [II] [III] [IV] [V] [VI] [VII] [VIII] [IX-3R]		6,265 10,460 10,505 10,550 10,550 10,550 5,615 3,780 2,370	2,200 1,560 1,560 1,540 1,490 1,540 1,540 1,540 1,970	1,783 1,750 1,748 1,752 1,730 1,725 1,725 1,855 3,17	1805 2700 2575 2260 1845 1730 960 975 1050
Contrapluma con mecanismos, pasteca y plumin Counterjib with mechanisms, reeving block and auxiliary jib Contre-flèche avec mécanismes et fléchette auxiliaire Противовесная консоль с механизмами и вспомогательной дополнительной стрелой Mekanizmalı kuiruk ve yardımcı kol uzantısı الذراع المعاكس مع آليات وريشة مساعدة			7,150	2,241	2,495	19070
Contrapluma con elevacion pluma, pasteca y plumin Counterjib with luffing mechanisms, reeving block and auxiliary jib Contre-flèche avec mécanisme de relevage de la flèche, moufle et fléchette Противовесная консоль с механизмом подъема стрелы, блоком и дополнительной стрелой Kaldırma kolu, makara düzenekli ve kol uzantılı kuiruk الذراع المعاكس مع رافع الذراع والبكرة والريشة الإضافية			7,150	2,218	2,495	10405
Mecanismo elevacion carga / Hoisting mechanism / Mécanisme de levage de charge / Подъем груза / Yük kaldırma / رافع الحمولة			2,208	2,539	2,068	8665
Polipasto / Hook assembly / Palan / Полуснаст / Kanca takımı / بكرة	TD/2R/3R TD		1,101 0,150	0,340 0,278	1,692 1,715	800 240
Tirante sostén pluma / Jib support tie / Tirant de fleche / Растяжка поддержки стрелы / Kol destek bağları / مشد دعامة الذراع			5,850	0,430	0,615	2375
Parte superior Top part			11,947	2,222	0,878	6970
Plataforma y cabina (2 x 1,5) / Platform and cabin / Plateforme et cabine / Платформа и кабина / Platform ve kabin / منصة وكابينة			4,000	1,905	2,335	1190
Transporte torre de montaje/ Jacking cage transport / Transport de tour de montage / Транспортировка монтажной башни / Kaldırma kafesinin taşınması / نقل برج التركيب	TM20PASR-5,6		10,820	2,285	2,395	12140
Contrapeso / Counterweight / Contrepoids / Противовес / Denge ağırlığı / اوزان معاكسة			4,500	0,235	0,800	6000
Contrapeso / Counterweight / Contrepoids / Противовес / Denge ağırlığı / اوزان معاكسة	Lastre / Ballast / Lest / Балласт Alt ağırlık taşları / ثقل		3,8	0,58	1,5	6000



JASO EQUIPOS DE OBRAS Y CONSTRUCCIONES, S.L.



FEM 1005 – C25

Reservado el derecho a modificaciones sin previo aviso. Declinamos toda responsabilidad derivada de la información proporcionada / Subject to modification, without previous warning. This information is supplied without liability / L'entreprise se réserve le droit de procéder à des modifications sans préavis. Nous déclinons toute responsabilité quant aux informations fournies / Мы оставляем за собой право на внесение изменений без предварительного уведомления. Мы снимаем с себя любую ответственность в отношении предоставленной информации / Önceden bildirilmeksizin değiştirilebilir. Verilen bilgiler için hiçbir sorumluluk kabul etmemekteyiz / حقوق التغيير محفوظة دون إشعار مسبق. دون أدنى مسؤولية عن المعلومات المقدمة

Fecha / Date: 10-09-2014

