



BIGMAX[®]

by TECHNOCRANE

BIGMAX Cranes

TCH Series Heavy Duty Telescopic Cranes

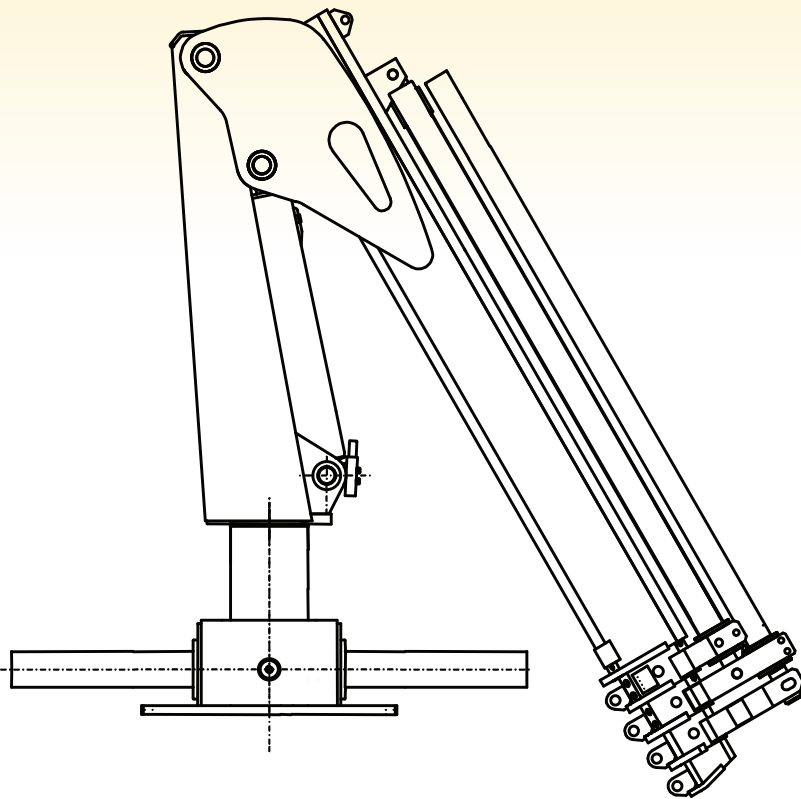
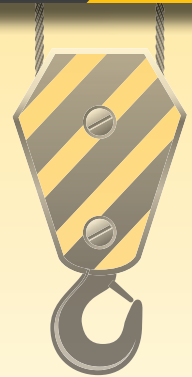

Strength

- Designed for harsh marine and industrial applications
- Strong, light weight hexagonal boom construction
- Fabricated from high tensile steel
- Rugged steel base with double rack and pinion slewing system
- Two year comprehensive parts and labour warranty

Choice

- Four models 27,400 to 74,300 ft lbs (3.8 to 10.3 t/m)
- Up to 4 hydraulic extensions to 31 feet
- Three levels of corrosion proofing
- Range of outrigger stabilizers to fit
- Winches and other options available

Safety

- Counterbalance safety valve mounted directly to main lift cylinder
- Active and passive overload and hose failure protection
- Control valve supplied loose for maximum visibility when mounted
- Complies with ANSI B 30.5, DIN 15018 and EN12999 Standard

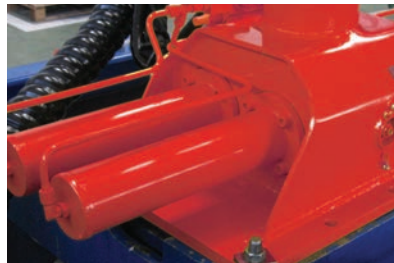
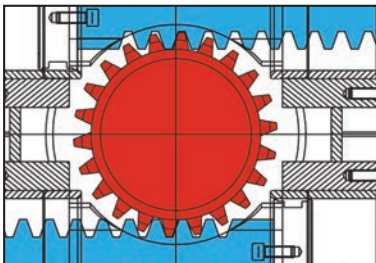

www.bigmaxcranes.com

BIGMAX by Technocrane

Toll free: 877-531-8644 | info@bigmaxcranes.com

TCH Series Reach and Load Chart

TCH 400.2
TCH 400.3
TCH 400.4

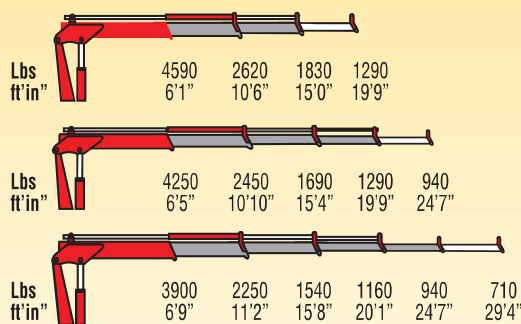

TCH 700.2
TCH 700.3
TCH 700.4

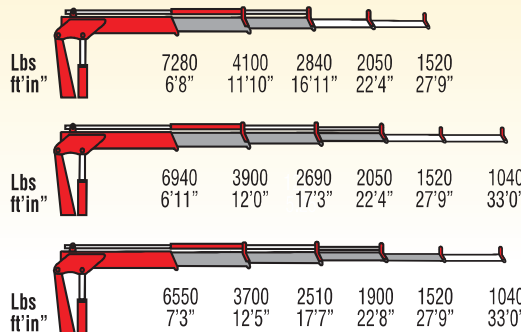

TCH 850.2
TCH 850.3
TCH 850.4

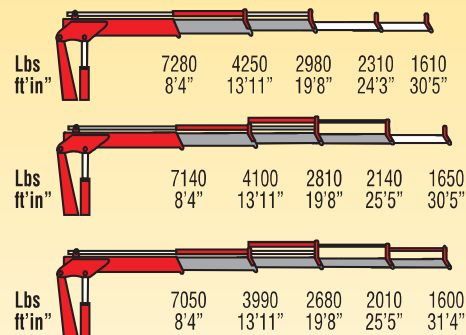

TCH 1050.2
TCH 1050.3
TCH 1050.4

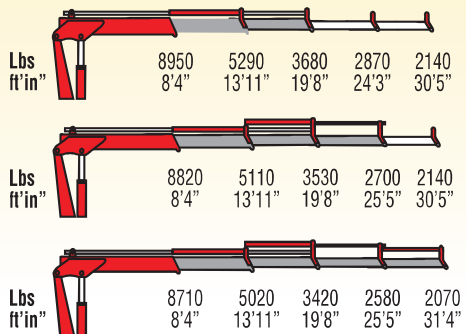

TCH SERIES SPECIFICATIONS

MODEL	Maximum Lift	Maximum Reach	Base Crane Weight (Lbs.)	Dimensions (inches)		
				Height	Width	Depth
TCH 400	4,590 lbs @ 6'1"	29'4"	1,260	73	78	19
TCH 700	7,280 lbs @ 6'8"	33'0"	1,630	78	87	23
TCH 850	7,280 lbs @ 8'4"	31'4"	2,370	88	79	23
TCH 1050	8,950 lbs @ 8'4"	31'4"	2,370	88	79	23

Contact us for a price quote today!

Fast delivery as most models delivered from stock!

CRANE OPTIONS

1. Winch: a winch can be installed on most TCH models to increase vertical lift capability.

2. Radio/Wireless Controls: hand held or wired controls are available for enhanced safety and convenience.

3. Accessories: rotators, grabs and augers are available for most TCH models.



BIGMAX CRANES
by Technocrane

4165 Packalen Blvd.
Garden Bay, BC
Canada V0N 1S1

Office: 604-575-2103
Toll free: 877-531-8644
Fax: 604-648-9852
info@bigmaxcranes.com



www.bigmaxcranes.com