

WT 850 / WT 1000

WUMAG PALFINGER



Maximum job performance

Revolutionary construction



A true space-saver

The WT 1000 possesses the special ability of being able to slew its boom system laterally into operating position as soon as its main boom is lifted slightly. The rear of the vehicle can get very close to the object.



WT 850

The WT 850 is ideal for the construction, inspection and cleaning of large buildings. A working height of 84 meters basically says it all. Yet the lateral outreach of 30 meters only underscores the platform's great potential. This articulated access platform can be mounted on a standard 48-ton chassis with five axles (3 steerable) chassis. This enables a turn radius of only 14 meters. Another solid argument for the WT 850 is its high degree of reliability, which can be seen especially during intensive assembly work.

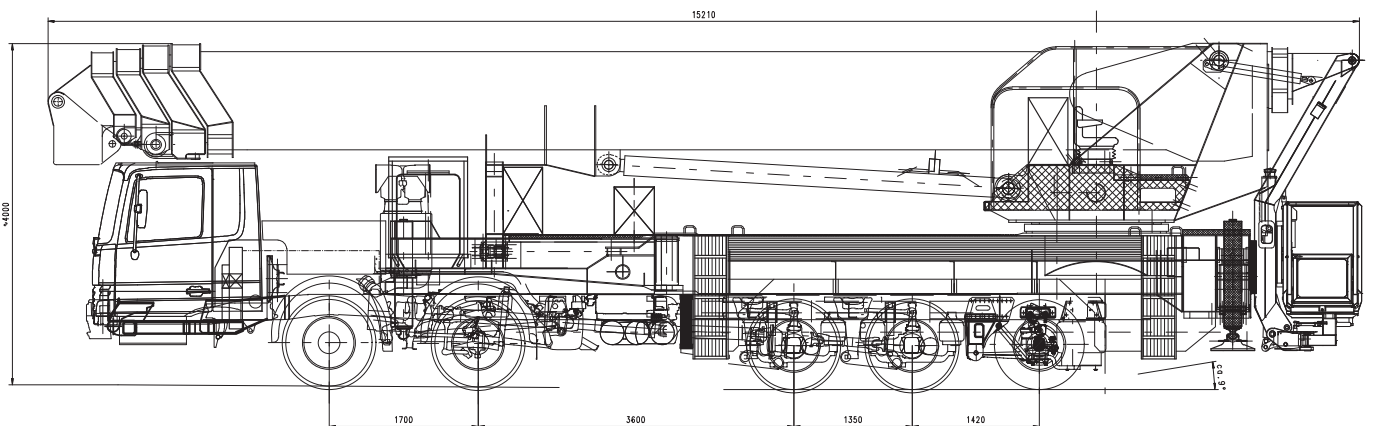

Well-established technology

WT 850 Working range

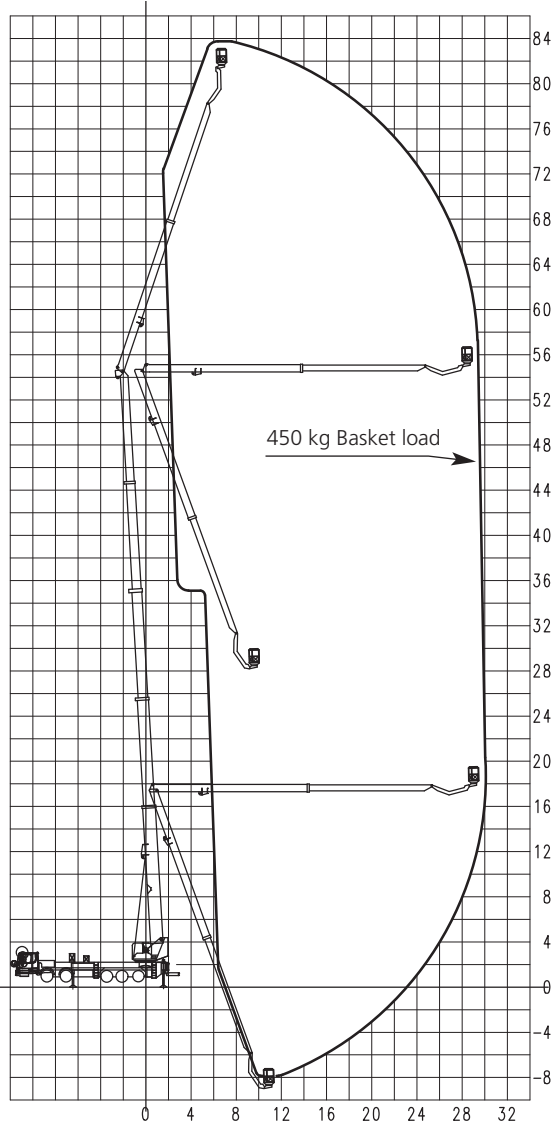

Technical Data WT 850

Specifications of basic model

Max. working height	84 m
Max. basket floor height	82 m
Max. horizontal outreach of standard basket (with ... kg basket load)	30.0 m / 450 kg

Boom system

Number of extensions (lower boom/upper boom)	4/1
All power guides and hydraulic and mechanical equipment internally routed and optimally protected against damage	standard
Hydraulic jib boom, working range	110°
Hydraulic Upper boom, working range	160°
Automatic return of main boom to transport position "Home Function"	standard

Workman basket

Standard basket:	3.88 / 2.15 x
Telescopic basket (WxLxH)	1.05 x 1.10 m
Optional basket: without telescopic function (WxLxH)	2.47 x 1.05 x 1.10 m
Slewing range of basket	2 x 84°
Full load	450 kg
with the telescopic workman basket	450 kg
Full load with the telescopic workman basket (optional)	500 kg
Motor Start/Stop in the workman basket	standard
Synthetic cover on control panel	standard
230/400 V CEE outlet in the workman basket	standard
5 anchor points to secure safety belt	standard
Displaceable control panel	standard
Graphic display	standard
Reversible slewing direction after panel relocation	standard
Collision protection for basket and jib boom	standard
Battery voltage monitoring in the basket	standard

Stabilizers

Function of stabilizers	swing-out and H-type stabilizer, half-sided / full extended
Max. stabilizer spread - both sides horizontally extended	8.00 m
Stabilizer control at the base	standard
Automatic outrigger system and set-up levelling,	standard
Max. permissible inclination 0°	standard
Blinking lights on the stabilizer extensions	standard
4 Safety plates	standard

Slewing system

Slewing range	endless
---------------	---------

Carrier vehicle and installation

GVW class	at least 48 t
Length in transport position	14.99 m*
Width in transport position	2.55 m*
Height in transport position	3.99 m*
Angle of slope	ca. 10° *

*) depending on carrier vehicle

Manual and emergency controls

Integrated at the secondary remote control	standard
Emergency lowering system in the basket	standard
Back-up/Emergency control at the base with seat	standard
Diesel-emergency pump	standard
Dead man's device	standard
Oil type Synthofluid PE-815 (Bio-oil)	standard

WT 1000

The largest access platform in the world is regarded as the Queen of the Skies – the WT 1000 by WUMAG PALFINGER. It was developed for assembly and maintenance work on wind turbines. Mounted on a 5-axle all-terrain mobile crane chassis, the WT 1000 can go just about anywhere. Its heavy-duty workman basket can carry nominal loads of up to 600 kg. Since it can be set up in four different stabilizing configurations, the WT 1000 can also be operated in tight spots.

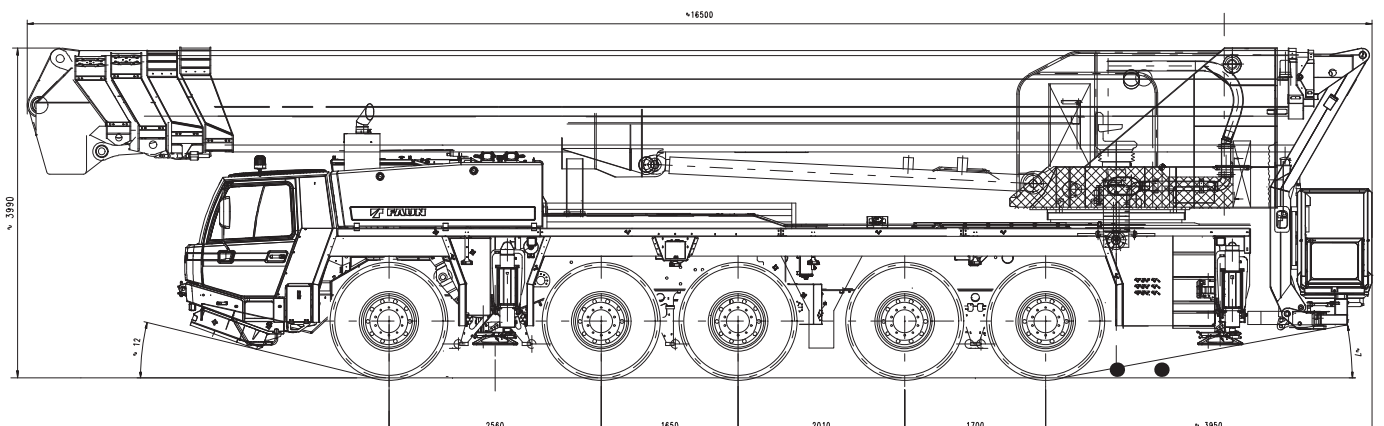

A masterpiece of engineering

WT 1000 Working range

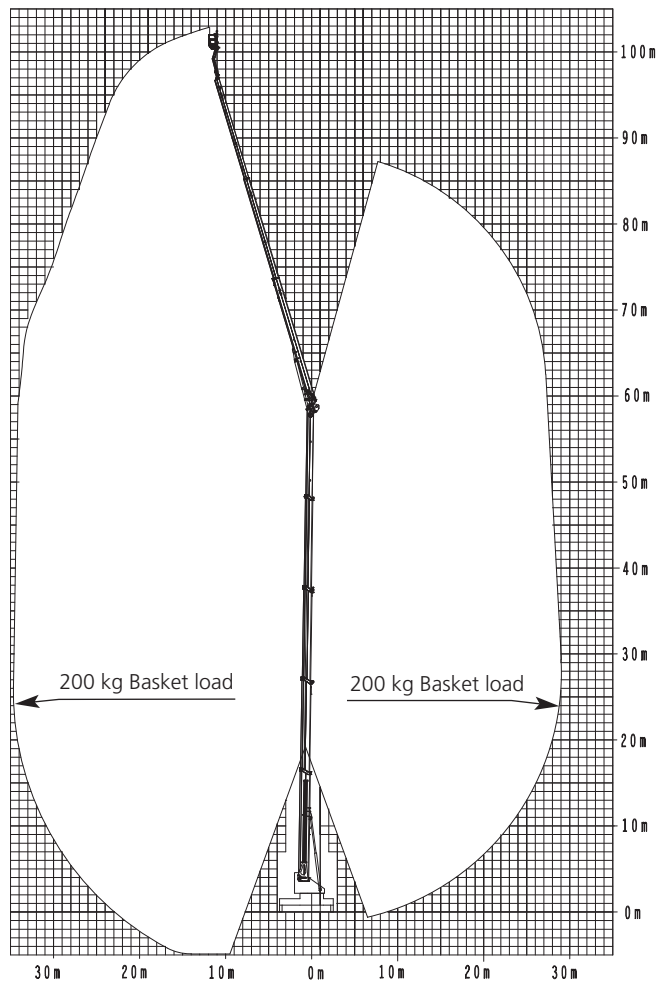

Technical Data WT 1000

Specifications of basic model

Max. working height	102.50 m
Max. basket floor height	100.50 m
Max. horizontal outreach of standard basket (with ... kg basket load)	35.0 m / 200 kg

Boom system

Number of extensions (lower boom/upper boom)	4/2
All power guides and hydraulic and mechanical equipment internally routed and optimally protected against damage	standard
Hydraulic jib boom, working range	115°
Hydraulic Upper boom, working range	163°
Automatic return of main boom to transport position "Home Function"	standard

Workman basket

Standard basket:	3.88 / 2.15 x
Telescopic basket (WxLxH)	1.05 x 1.10 m
Optional basket: without telescopic function (WxLxH)	2.47 x 1.05 x 1.10 m
Slewing range of basket	2 x 84°
Full load with the telescopic workman basket	530 kg
Full load with the telescopic workman basket (optional)	600 kg
Motor Start/Stop in the workman basket	standard
Synthetic cover on control panel	standard
230/400 V CEE outlet in the workman basket	standard
5 anchor points to secure safety belt	standard
Displaceable control panel	standard
Graphic display	standard
Reversible slewing direction after panel relocation	standard
Collision protection for basket and jib boom	standard
Battery voltage monitoring in the basket	standard

Stabilizers

Function of stabilizers	H-type stabilizer, half-sided / full extended
Max. stabilizer spread - both sides horizontally extended	8,05 m
Stabilizer control at the base	standard
Automatic outrigger system and set-up levelling,	standard
Max. permissible inclination 0°	
Blinking lights on the stabilizer extensions	standard
4 Safety plates	standard

Slewing system

Slewing range	endless
---------------	---------

Carrier vehicle and installation

GVW class	at least 60 t
Length in transport position	ca. 16.4 m
Width in transport position	2.75 m
Height in transport position	ca. 3.99 m
Angle of slope	ca. 7°

Manual and emergency controls

Integrated at the secondary remote control	standard
Emergency lowering system in the basket	standard
Back-up/Emergency control at the base with seat	standard
Emergency drive through a separate hydraulic cycle of chassis	standard
Dead man's device	standard
Oil type Synthofluid PE-815 (Bio-oil)	standard

Your Reliable Partner

KP-WT850/1000M2-4E
E 09/08, K 04/10, D 04/10



Krefeld – Germany



Löbau – Germany