

GENERAL DIMENSIONS

Unit : mm

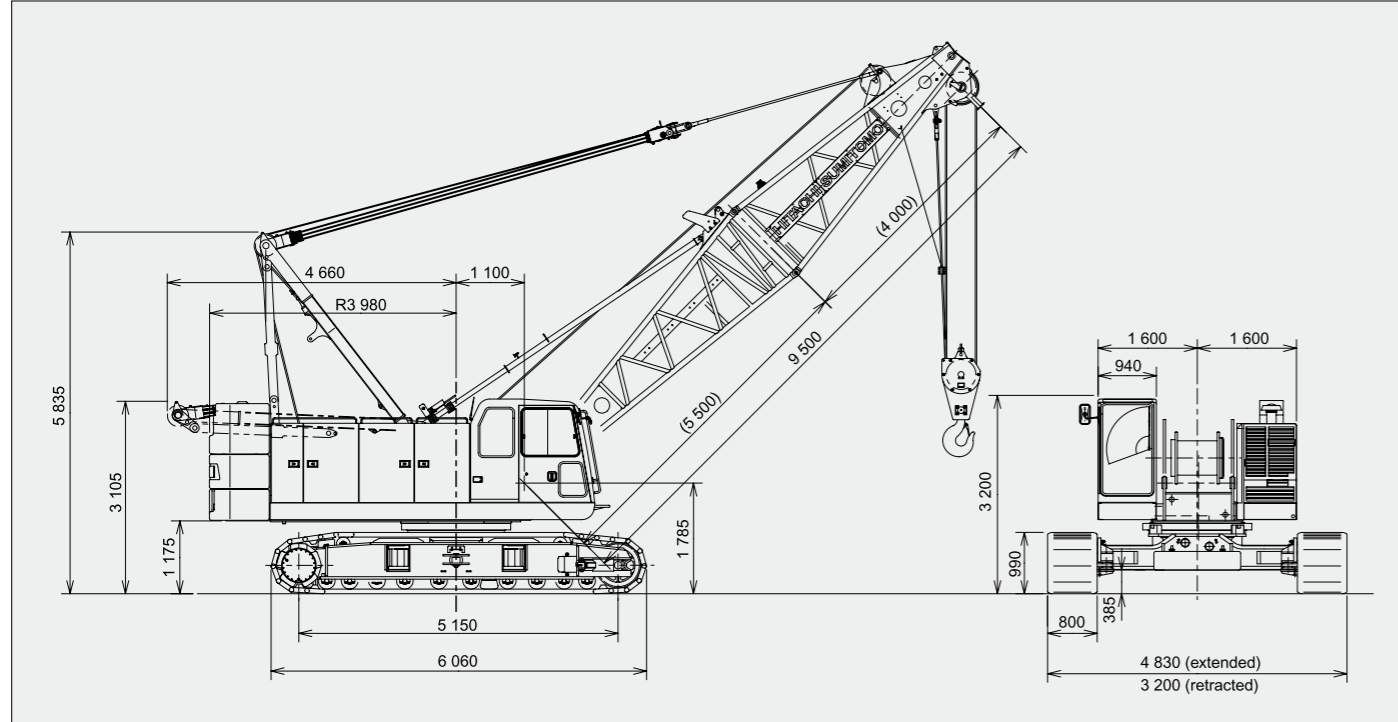

SPECIFICATIONS

| | | Liftcrane application | Clamshell application |
|---------------------------------------|-------------------|--|--|
| Max. lifting capacity | t × m | 80 × 3.3 | — |
| Basic boom length | m | 9.5 | 9.5 |
| Max. boom length | m | 54.5 | 21.5 |
| Fly jib length | m | 9.0 to 18.0 | — |
| Boom + fly jib length | m | 45.5 + 18.0 | — |
| Rope line speeds ^(*) | Front main drum | m / min | 105 |
| | Rear main drum | m / min | 105 |
| | Boom hoist drum | m / min | 68 |
| Slewing speed | min ⁻¹ | 3.9 | 3.9 |
| Travel speed high/low ^{(*)2} | km/h | 1.8 / 1.3 | 1.8 / 1.3 |
| Gradeability | % (°) | 30 (17) | 30 (17) |
| Engine | Make & model | Isuzu 6HK1X | Isuzu 6HK1X |
| | Rated output | kW / min ⁻¹ | 212 / 2 000 |
| Ground contact pressure | kPa | 89 | 90 |
| Operating weight | t | 75.1 (with / basic boom and 80 t hook block) | 77.7 (with / basic boom and 1.2 m ³ Clamshell bucket) |

Notes : 1. These figures are based on drum first layer and rated engine rpm with no load, and vary under load and operating conditions (*1).

2. Travel speed is based on flat, level and firm supporting surface, and under the conditions that no load must be applied and front-end attachment must be 9.5 m basic boom (*2).

•We are constantly improving our products and therefore reserve the right to change designs and specifications without notice.

•Units in this catalog are shown under International System of Unit ; the figures in parenthesis are under Gravitational System of Units as old one.

•Illustrations may include optional equipment and accessories, and may not include all standard equipment.

Address inquires to :

Hitachi Sumitomo Heavy Industries Construction Crane Co., Ltd.

9-3, Higashi Ueno 6-chome, Taito-ku, Tokyo 110-0015, Japan
Phone: 81-3-3845-1387 Facsimile: 81-3-3845-1394
<http://www.hsc-crane.com>

Printed in Japan
1211©05H.EA129-1d

SCX800-2

The New World Standard
Crawler Crane

Take a closer look. The SCX800-2. A new standard of 80 ton class crawler crane throughout the world.

From now on, the SCX800-2 will become a new world standard that matches and answers various demands and requirements from customer around the world. "Higher lifting performance", "job-proven controllability", "operator comfort", "superior safety", "transport ease", and "good environment". The SCX800-2 takes into its design these points under an advanced and accumulated technologies. Now, the SCX800-2 just comes around you.

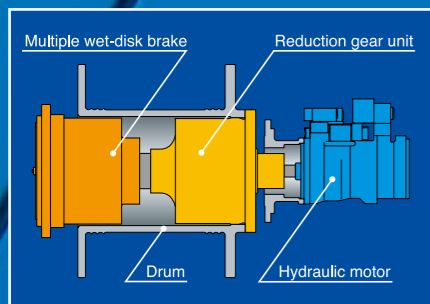

Advanced clutchless multiple wet-disk brake is well designed, and ensures continuous duty cycle operation.

The front/rear main winch drums and optional 3rd winch drum use a multiple wet-disk brake, and a forced-oil cooling system is designed to sustain brake performance even in continuous duty cycle operations grabbing.

The clutchless multiple wet-disk brake requires no maintenance.

This brake system requires no maintenance unlike a conventional drum brake with linings. Accordingly, it results in reducing the machine maintenance cost greatly.

A high viscosity hydraulic oil is standardized.

A newly developed mechanism is used on the brake design to reduce drag resistance and it realizes a smooth friction-off between discs even though the standardized high viscosity hydraulic oil is utilized, contributing to longer life of hydraulic pumps and motors.

An aluminium-make oil cooler.

For not only corrosion-resistance but also high cooling efficiency, an aluminium-make oil cooler is provided in front of engine radiator.

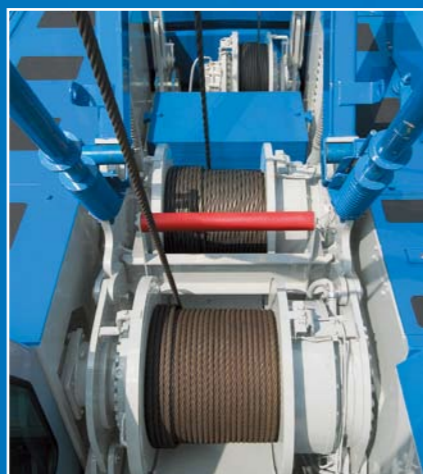

A really versatile machine with powerful winch drum.

The SCX800-2 is really a versatile machine and certainly performs not only liftcrane works but also duty cycle works with bigger line pull of 137 kN (14 t) as maximum with cable of 22.4 mm diameters.

Bigger drum horse power at widely used rope line speed range.

A bigger drum horse power (line pull by line speed) is realized under a new winch drum design with a specially-tailored power increase control system that maximizes engine output under any load condition in whole range of engine rpm.

Wider drum is designed.

In consideration of an efficient bucket work, front and rear main operating drums are able to wind up approx. 37 m long cable at drum first layer with 23 windings; it accordingly results in longer cable life under a right cable winding into drum.

Optional third drum.

A third drum is optionally available under the same structural specifications as that of two main operating drums except drum width and flange diameter, and an 137 kN (14 t) max. line pull as same as that of two main drums is available. It accordingly enables to efficiently perform duty cycle works too.

Higher lifting performance

Max. line pull
137 kN (14t)

Rated line pull
68 kN (7.0t)



Job-proven certain controllability

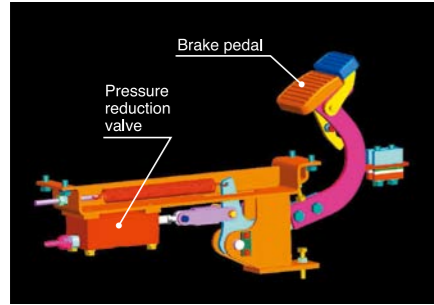

New negative brake system much reduces operator fatigue and enhances safety.

With a new negative brake of spring-applied/power hydraulically-released design applying dynamic hydraulic pressure for its release control, an effective braking can be done under an extreme light foot pedalling, and it accordingly results in greatly reducing operator fatigue especially during winch free-fall operations under duty cycle applications. Further, the use of negative brake system maintains a high level of brake safety even if a hydraulic pressure drop in the circuit happens.



A high operation ease with specially-tailored EPC system.

Thanks to unique EPC system, an easy-precise-minute control of engine rpm and pump discharge from min. thru max. is really possible at the same time by simply twisting the grip fitted on slewing control lever.

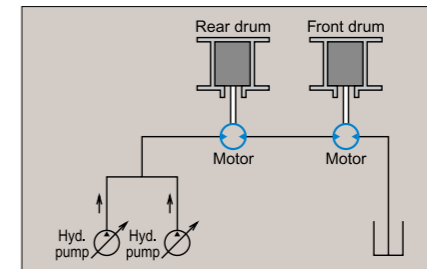

Drum rotation speed is easily synchronized.

Under a series hydraulic circuit on two main operating drums, the SCX800-2 allows the inexperienced operator to synchronize rope line speed of front and rear drums ranging all the way even a high speed range so that clamshell/Japanese MHL diaphragm wall excavating bucket operation can be easily and precisely performed.

A series hydraulic circuit is designed on front and rear drum winch motor hydraulic lines. Accordingly, oil flow capacity to each motor is equal, and as a fixed displacement axial piston motor is used on each drum, the drum rotation speed gets equal regardless of the difference of the load between front and rear drums.



Armchair control station with drum rotation sensors.

An armchair control station is provided for a good, easy and comfortable operation. In addition, armchair control levers of two main and boom hoist drums each fit the drum rotation sensor to let operator sense a drum rotation speed decrease/increase by a knob vibration per 11 mm cable winding/rewinding movement at 1st drum layer, and it results in performing more safety lifting work, especially in blind condition.



A good slewing & boom hoisting/lowering speed control design.

Boom hoist drum rotation speed can be freely controlled thru knob dialing independently for more precise combined operation of hook and boom motions. In addition, max. slewing speed can be freely controlled thru knob dialing too, and, as an example, it realizes a precise combined operation under higher hook hoisting and lower slewing speed in high lift work. Further, more smoother slewing can be realized in any kinds operations and works too because, as a main reason, a variable displacement axial piston pump is designed in slewing circuit.

Operator comfort with simplified & functional control station layout

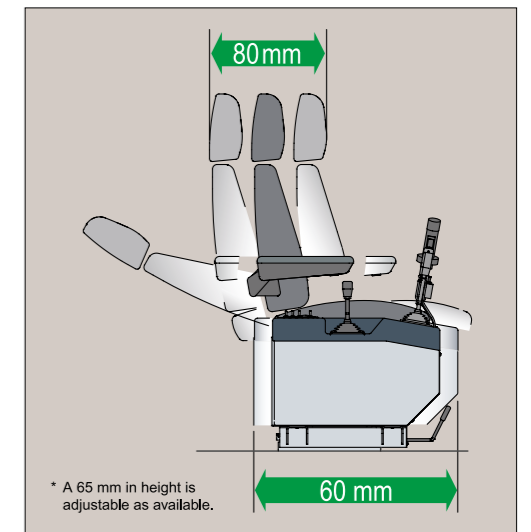

Slidable control station and operator seat.

To set most of suitable operator position, both right- and left-hand control stations are designed to simultaneously slide 60 mm back and forth together with operator seat, and operator seat is able to slide 80 mm independently too.

Control lever arrangement under human-engineering, and functional instrument panel design.

Further, control station and instrument panel are designed suitably for operator control ease with comfortable and natural position.

Simplified and easy-to-read panel.

A large LCD graphic display panel of Load Moment Indicator is provided with a reflection-less design on display panel. And, the switches, meters/gauges and controllers are functionally grouped for operator control.



A newly designed operator's cab.

In consideration of operator comfort, a new operator's cab much improves the visibility thru front and both side windows of the cab under simplified layout of control station. In addition, a reinforced light green-tinted safety glass is adopted in front window to protect operator from ultraviolet rays and airborne debris.

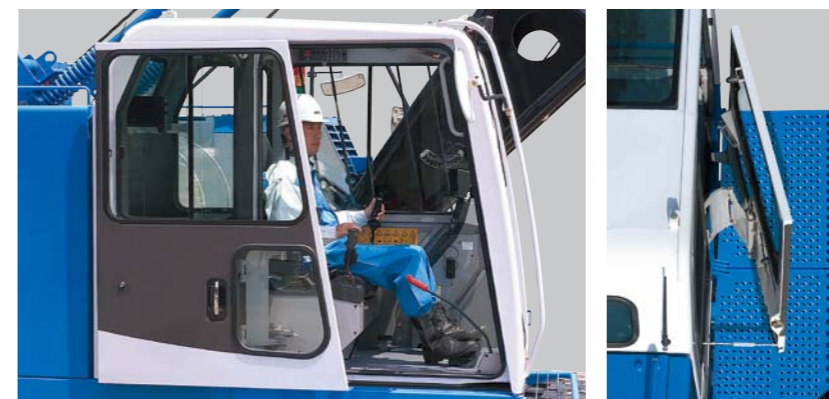

Cab large sliding door with a slewing-link design.

For easy entry and exit to and from the cab, and smooth door opening and closing, a slewing-link type large sliding door is designed. And, a slewing-link door design certainly eliminates a troublesome occurrences like a gathering the mud into rail groove, rail-rust and so on unlike rail-slide door.

Outside-air intake type air-conditioner.

For good air-conditioning with fresh air, an outside-air intake type air-conditioner is available.



Excellent reliability in every safety function



Our own designed new Load Moment Indicator.

The Load Moment Indicator (LMI) is reliable computerized safety device developed under our own accumulated technique in the past. An easy-to-read LCD graphic display panel is well designed and a reflectionless display panel is provided on a new LMI with setting ease of viewing angle. In addition, no zero-point adjustment, and data input thru interface counter-indication/message on display panel are available for easier and certain setting of operating conditions and LMI functions. Of course, "present lifting load", "rated load", "load ratio", "working radius", "boom angle", "engine rpm" and so on are indicated on the LMI display panel. Further, displayed picture and menu selection can be easily set up by panel switch in accordance with operation situation and condition.

Lifting height indication function.

For more safer lifting work especially in blind condition, it is available to indicate the lifting height above ground or depth below ground on display panel of LMI.



Boom speed slowdown function.

This function is available just before automatic stopping of boom motion at both upper and lower side limits of boom angle to prevent a shock even though control lever is still at hoisting/lowering position. This function is also available when over-loading in the case that working radius exceeds the specified one.

LMI automatically sets front-end att. erection mode with letter message.

In the range out of crane working area, the LMI display panel automatically indicates "Now, out of crane working range" with a rigging instruction, and it is available to lift front-end att. off ground without the influence of LMI safety functions, and, after front-end att. is lifted over the range of crane working area, LMI safety function gets back automatically for safe erection work.



Secondary boom over hoisting limiter.

Further to boom over-hoist limiting function by the limit switch and LMI safety circuit, an additional limit switch is located on boom backstops for redundant boom protection.

Automatic drum pawl locking device.

On boom hoist drum, it is designed to automatically lock and release drum pawl when control lever just returns to neutral position, and just actuates.

Slewing and travel alarms.

These alarms alert work crew around the machine when slewing and/or travelling to keep clear for safety.

Optional 3-color percentage indicator.

To let work crew around the machine know operating conditions of "safety" or "marginal" or "over-loading" with a 3-color of "green" or "yellow" or "red". As a further function, red lamp comes on automatically whenever operator cuts off LMI safety circuit absentmindedly.



Independent lever lock.

Control lever can each be mechanically locked to prevent absent-minded misoperation.



Standardized safety devices other than the above

- Main hook over hoisting limiter;
- LMI safety circuit-off switch
- Slewing brake safety circuit;
- Non-drum brake preventing device;
- Free-fall interlocking device;
- Lock lever (Fool proof shut-off lever);
- Drum pawl locks;

Faster assembling/disassembling and a good transportability

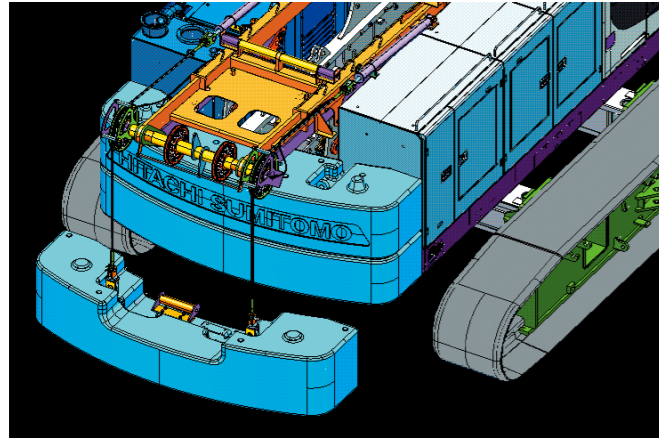

Optional counterweight self-removal device.

It is able to raise and lower each counterweight by a gantry with two power hyd. cylinders.

Optional lower frame jack-up device.

Lower frame jack-up device gets faster assembling/disassembling of two crawler side frames, and it is allowed to transport basic machine with boom base section in 26 t weight.



Counterweight with horizontally-split design.

It is able to load boom extensions onto counterweight when transport. And, the reversible stack is possible to reduce the time for disassembling/assembling works.

Basic machine transport outline

1 Attach lower frame jack-up device on to lower frame, and disassemble two crawler side frames.

2 Set up trailer bed under lower frame, and load the machine on to trailer by cylinder retraction.

3 Disattach lower frame jack-up device.

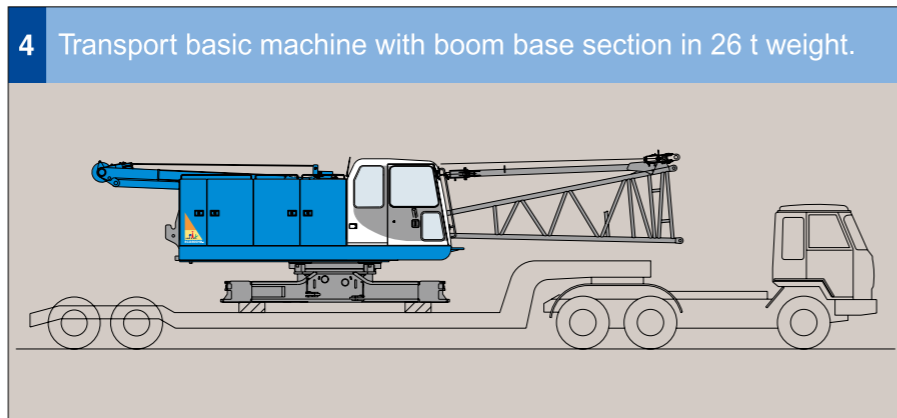

A Keen Attention to Environment

The prime mover is from ISUZU, a reliable diesel engine manufacturer, and meets current EU Emission Regulations for Off-Road Diesel Engine - Stage 3.

Standard version

SCX800-2

■ Max. lifting capacity:

80 t × 3.3 m

■ Max. line pull:

137 kN (14 t)

