

Features four-wheel  
drive for the  
tough applications



- \* Rated Capacity Limiter ... Standard
- \* Capacity on outriggers ... 9,000 lbs.
- \* Pick and carry capacity ... 7,200 lbs.
- \* Height ... 6' 9"
- \* Width ... 5' 4"
- \* Boom rotation ... 360 Degree continuous
- \* Sheave height up to 33' 6"
- \* Horizontal reach up to ... 27'
- \* Tight turning radius
- \* 4-Wheel steer ... Standard
- \* 4-Wheel drive ... Standard
- \* Fully hydraulic controls for smooth precise operation
- \* Independent outrigger controls
- \* Dual fuel Standard, Diesel Optional

**BMC**® **BRODERSON**®  
**Manufacturing Corp.**  
P.O. Box 14770, Lenexa, KS 66285-4770  
(913) 888-0606 • FAX (913) 888-8431  
website: [bmccranes.com](http://bmccranes.com)

# IC-40-A

CAPACITIES APPLY TO OPERATION ON FIRM LEVEL SURFACE					
LOAD RADIUS FEET	MAIN BOOM OR EXTENSION CAPACITIES IN POUNDS				
	360° ROTATION		OVER FRONT		
	ON RUBBER	ON OUTRIGGERS	ON RUBBER	ON OUTRIGGERS	
4	7000	8500	7200	9000	
5	5000	7000	6000	7000	
6	3700	5850	5300	5850	
8	2300	4150	4150	4150	
10	1450	3400	3200	3400	
12	1050	2850	2400	2850	
14	900	2350	1900	2450	
16	750	1900	1600	2150	
18	650	1600	1300	1950	
19	600	1450	1150	1850	
20	550	1450	1150	1600	
22	450	1250	1000	1450	
24	400	1050	850	1300	
26	350	850	750	1150	
27	300	750	650	1100	

  

8' BOOM EXTENSION	8-FOOT BOOM EXTENSION - STRAIGHT OR OFFSET							
	MAIN BOOM ANGLE							
	ANGLE	0°	10°	20°	30°	40°	50°	60°
* 0°	1100	1200	1300	1450	1600	1850	2300	3500
* 15°	—	—	1100	1250	1350	1500	1700	2050
* 30°	—	—	—	1100	1200	1300	1450	1600

\* USE 0° FOR STRAIGHT BOOM EXTENSION.  
 \* USE 0°, 15° OR 30° FOR OFFSET BOOM EXTENSION.

CAUTION: BOOM EXTENSION LOADS MUST NOT EXCEED MAIN BOOM CAPACITY. BOOM EXTENSION DEDUCT: 100 LBS. WHEN STOWED ON BASE BOOM, DO NOT PICK AND CARRY WITH LOADS ON BOOM EXTENSION.

CAPACITIES ON OUTRIGGERS ARE 85% OF TIPPING LOADS. CAPACITIES ON RUBBER ARE 75% OF TIPPING LOADS. CAPACITIES BELOW BOLD LINE ARE LIMITED BY TIPPING. OTHER CAPACITIES ARE LIMITED BY STRUCTURAL OR HYDRAULIC CAPABILITIES. MAXIMUM HYDRAULIC PRESSURE 2600 PSI.

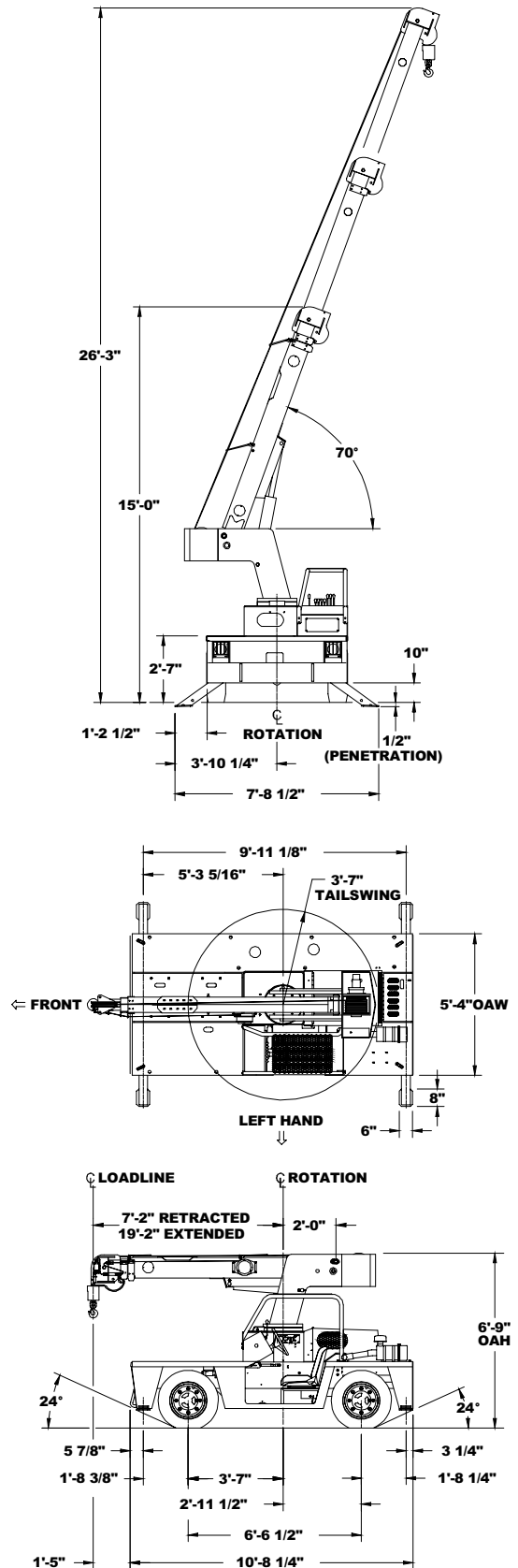
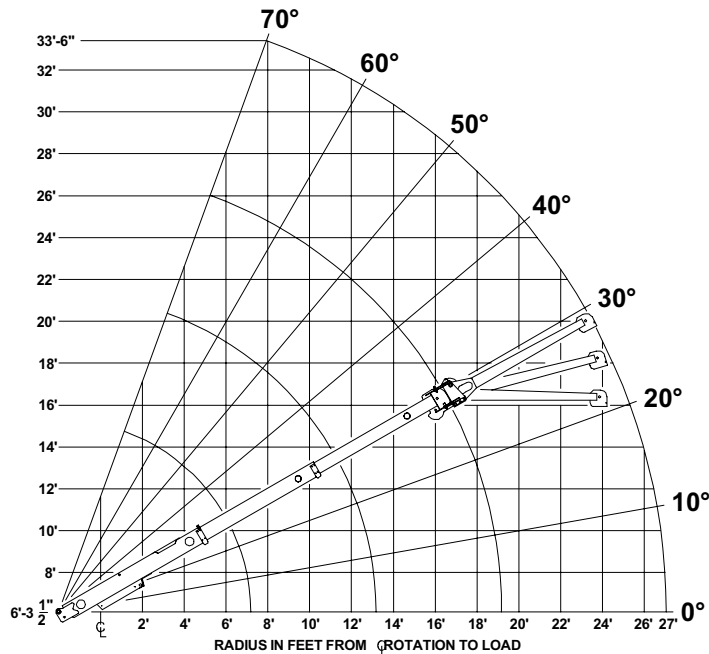
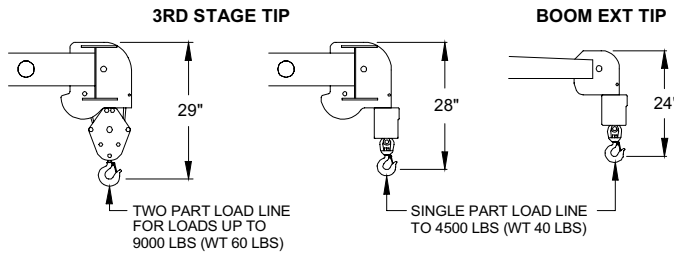

## General:

<b>Weight</b>	8,840 lbs.
<b>Travel Speed</b>	0 to 10 mph
<b>Drawbar Pull</b>	2,000 lbs.
<b>Gradeability</b>	25% (14 degrees)
<b>Boom Movements:</b>	
Rotation	Continuous Rotation
Elevation	0 to 70 degrees
Extension	7 ft. 2 in. to 19 ft. 2 in.
<b>Boom Speeds:</b>	
Rotation	1.4 RPM
Elevation	17 seconds
Extension	31 seconds

Engine:	Standard	Optional
Make	Nissan	Cummins
Model	H20	A2300
Type	Gas/Dual Fuel	Diesel
Cylinders	4	4
Displacement	121 CID	140 CID
HP @ Governed speed	51 HP	50 HP
Fuel Tank Capacity	13.5 Gallons	

## Hydrostatic Pump:

Piston type, direct driven from engine crankshaft. Maximum flow 34 GPM, maximum pressure 4,000 PSI.

## Axles:

### Front Drive Axle:

Planetary drive/steer axle with an overall 16:15/1 ratio. Differential is limited slip. Axle is rigidly mounted to frame.

### Rear Steering Axle:

Planetary drive/steer axle with an overall 16:15/1 ratio. Differential is limited slip. Axle oscillates 1-1/2 degrees in either direction.

## Steering:

Full hydraulic steering unit controls steering cylinder attached to each axle. Limited steering if engine dies.

## Brakes:

Primary braking from hydrostatic transmission. Foot-actuated wet-disc brakes in each axle for additional braking in some conditions. Lever actuated parking brake to hold crane when not being driven.

## Tires:

28 x 9 - 15 pneumatic tires, 14 PR. Pressurized to 120 PSI for crane rated loads.

## Chassis:

### Cargo Deck:

29 square feet deck area, 6,000 pounds capacity when centered over front axle or to the rear of front axle.

### Outriggers:

Four hydraulic outriggers of box-beam construction. Independent controls for each. Hydraulic cylinders are equipped with direct-connected holding valves.

## Chassis: (Cont'd)

### Lifting Rings:

Consists of four rings, one at each corner of the load deck.

### Pulling Eye:

Mounted on front bumper.

## Operator's Compartment

Provides one-position access to all chassis and crane functions. Includes adjustable operator's seat, retracting seat belt, fire extinguisher and bubble level.

## Electrical System:

### 12 Volt System

**Lighting Group:** One pair headlights and taillights.

### Instrument Group:

Fuel, ammeter, oil pressure, water temperature, hydraulic oil temperature gauges & hourmeter. Gauges are lighted.

### Outrigger Alarm System

Two-tone alarm is activated when "Outrigger Down" controls are operated.

### Back-Up Alarm:

Provides pulsating 97 decibel sound when transmission is in reverse.

## Hydraulic System:

Tandem pump mounted to rear of hydrostatic piston pump. Delivers 6 GPM at 2,600 PSI for boom circuits & 18 GPM at 2,350 PSI for hoist circuit. System protected by relief valves. Hydraulic oil tank has 14 gallons capacity. Hydraulic oil cooler provided.

## Boom:

### Boom Assembly:

Three-section boom assembly equipped with bearing pads, double-acting hydraulic cylinders equipped with direct-connected holding valve and boom angle indicator on side of boom.

### Boom Rotation:

Heavy-duty ball bearing rotation gear with external teeth. Rotation is powered by hydraulic motor & worm gear drive.

### Boom Hoist:

Turret-mounted, planetary gear hoist, hydraulically powered with bare drum line pull of 5,000 lbs. and a line speed of 86 FPM. Hoist includes 85 ft. of 3/8 in. wire rope, down-haul weight, swivel hook and sheave block for 2-part line.

### Anti-Two-Block Device:

Prevents damage to hoist rope and/or crane components. Dumps hydraulic flow for Hoist Raise, Telescope Extend and Boom Lower.

### Sheave Block

Single sheave block for 2-part line requirements.

### Rated Capacity Limiter:

Warns operator of impending overload with audible and visual signals. Prevents overload by stopping boom functions that cause overloads.

# IC-40-A

Listed below are brief descriptions of each option available for the IC-40-A Industrial Crane. Consult the IC-40-A Engineering Spec for additional information on each option.

## IC-40-2A, 4-1/2 Ton Industrial Crane with Dual Fuel Engine (Gas/LPG).

### Engine Options:

#### Cummins 2.3L Diesel Engine

Cummins Model A2300, CARB Tier II and EPA Tier II Certified.

#### Spark Arrester Muffler

Installed in addition to standard muffler.

#### Engine Shut Down Gauges

Shuts engine off when high water temperature or low engine oil pressure occurs. Diesel only.

### Tire Option:

#### Foam Filling of Tires

#### Spare Tire & Wheel

28 x 9 - 15, 14-ply

### Chassis Options:

#### Auxiliary Winch

Mounted behind front bumper, hydraulically driven with control in operator's console (3,000 lbs. @ 20 FPM).

#### Pintle Hook - Rear

Holland "T-60-A" pintle hook mounted on rear of frame. 5-ton capacity.

#### Lifting Sling

Sling to attach to Lifting Rings.

#### Headlight & Taillight Grilles

Welded steel protective grilles for headlights and taillights.

### Operator Compartment Options:

#### All Weather Cab

Rigid-mounted canopy section and removable hinged door. Includes heater, windshield wiper, defroster fan, domelight & sliding window in door. Cannot be used with Operator Guard.

#### Cab Heater

Heater with two-speed fan, for units without All Weather Cab.

#### Operator Guard

Tubular steel weldment with heavy expanded steel mesh top section.

### Electrical Options:

#### Strobe Lights

Two yellow strobe lights mounted to turntable.

#### Boom Work Lights

One work light mounted to boom to light boom tip and one work light mounted to turret to light ground under boom tip.

### Boom Attachment Options:

#### Boom Extension

8 foot, boom stowable.

#### Boom Extension, Offset

8 foot, boom stowable, the boom extension is offsettable to 3 different positions. 0 degree (inline), 15 degree and 30 degree offset.

#### Searcher Hook

2,000 pound capacity. Swivel hook with spring latch hangs from support structure projecting outward from boom tip.

Should you, as the end user, require an option or special equipment on your IC-40-A that is not listed on our sales literature, please contact your dealer sales-person or the factory to receive a special quoted price.

**BMC<sup>®</sup> BRODERSON<sup>®</sup>**  
**Manufacturing Corp.**

P.O. Box 14770, Lenexa, KS 66285-4770  
(913) 888-0606 • FAX (913) 888-8431  
website: [bmccranes.com](http://bmccranes.com)