

**ROUGH
TERRAIN
CRANE**

RK450

SPECIFICATIONS

Max. Lifting capacity: 45.0 metric tons x 3.0 meters
Max. Boom Length: 39.0 meters
Max. Total Length (boom + jib): 54.0 meters

KOBELCO
◆ KOBELCO STEEL, LTD.

Specifications

UPPER STRUCTURE



SWING UNIT

A hydraulic piston motor drives the swing pinion through a deck-mounted planetary gear reducer for 360° continuous rotation.

Hydraulic flow into the swing motor is controlled by a manual valve in the swing circuit. The brake valve allows the operator to select free or automatic braking when the swing control lever is set in neutral.

SWING PARKING BRAKE

Manual disc brake.

SWING GEAR

Internal spur gear.

SLEWING RING

Integral with the swing gear, with a single row of ball bearings.



WINCHES

Mounted side by side, Power raising and lowering with inching capability, and free fall. Hydraulic motor drive, spur gear reduction, and counterbalance valve.

CLUTCHES

Internal-expanding, hydraulic shoe type.

BRAKES

Band type, with positive and negative brake modes.

DRUMS

360mm P.C.D., with 630mm diameter flanges. Width: 446.3mm (main) and 294.3 mm (auxiliary).

HOIST CABLES

IWRC6xFi (22+7) c/o spin-resist cable. Diameter: 18mm. Length: 175m (main) and 120m (auxiliary). U4xSec (39) non-spin cable optionally available.

BOOM HOIST

One-double acting hydraulic cylinder with holding valve, and boom angle indicator mounted on the base boom section.



BOOM TELESCOPE

Full power telescoping by three hydraulic cylinders with holding valves and telescoping assistance cables for the boom tip section.

CONTROLS

Five adjustable hand control levers for swing, telescope, main winch, auxiliary winch, and boom hoist (with pedal). These can be tilted in three neutral positions and stored in their bases when not in use. Other controls include: two short levers for main and auxiliary winch clutches and negative brake ON-OFF; one short lever for swing parking brake; one lever for telescope change over; one lever for transmission gear selection; swing lock pin; winch drum lock knobs; two pedals for main and auxiliary winch drum brakes; one pedal for engine throttle control; and one travel brake pedal.



OPERATOR'S CAB

All-weather; wide-view cab with safety glass, sliding door; roll-down window, and sashless roof window with wiper. Adjustable driver's seat with seat belt. Auxiliary seat behind driver's seat.

SAFETY DEVICES (Standard)

Overhoist shut-off, relief valves in hydraulic circuits, holding valves for boom hoist and telescope cylinders, counterbalance valve for winch motor, Check and Safety Monitor, overload warning device (automatic shut-off), winch drum locks, swing brake lock pin, lock valves for vertical cylinders on outriggers, emergency steering system, about-face steering compensator valve, axle lock-out valve, and swing flasher lamps, Programmable Operating Zone System, Automatic Outrigger Extension Sensor, and Automatic Swing Arrest, free-fall interlock and safety lock lever.

HYDRAULIC SYSTEM



PUMPS

Three gear pumps and two variable plunger pumps deliver power to the upper structure and outriggers. The first and second plunger pumps are paired and driven by power take-off. The third, fourth and fifth pumps are paired and directly driven. The first pump actuates the boom hoist, boom telescope, and winch assist; the second pump actuates the outriggers, and winch system; the third pump actuates the swing and steering the fourth pump actuates the pilot circuits for the clutches and negative brake cylinders, steering assist, the cab air conditioner. The fifth pump assists steering system and optional sky tilt jib and power twist.

MOTORS

Two plunger motors power the main hoist, the auxiliary hoist, and the swing.

CONTROL VALVES

Upper

One 5-stack set for the winch, boom telescope, and boom hoist; one 2-stack set for the clutch and brake; one 1-stack set for the swing.

Lower

Seven solenoid valves for the outriggers and suspension system; one 2-stack set for steering.

OIL RESERVOIR

Capacity 575 liters



EQUIPMENT (Standard)

Radio, windshield wiper/washer, cigarette lighter, ashtray, sun visor, floor mat, engine tachometer, tachograph, hourmeter, engine over running alarm, paper-element air cleaner, two working lights, horn, sensor malfunction, cab heater/defroster, air conditioner, towing hooks (one front, one rear) oil cooler for hydraulic system.

EQUIPMENT (Optional)

Extra oil cooler, remote backmirror, and outrigger plates.

CARRIER

TYPE

4-wheel drive (4x4), with 2-wheel (4x2) drive select for high speed mode.

FRAME

Wave shaped frame construction.

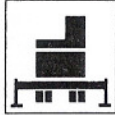

OUTRIGGERS

KOBELCO hydraulic H- or X-type outriggers. Eight double-acting hydraulic cylinders provide independent horizontal and vertical movement for each outrigger. Outriggers can be set from inside the cab or at the side of the carrier. Both outriggers feature self-storing floats.



POWER PLANT

Mitsubishi 6D22TC intercooled, turbocharged, water-cooled diesel engine with 4 cycles, 6 cylinders, and direct injection.

Max. output (DIN) 320 PS at 2,200 rpm

Max. torque (DIN) 118kg-m at 1,400 rpm

Displacement 11,149kg

ELECTRICAL SYSTEM

24-volt DC system with two 12-volt, 150 Ah batteries

FUEL TANK

Capacity 300 liters

TORQUE CONVERTER

Single-stage, torque converter with automatically controlled lock-up clutch.

TRANSMISSION

8-speed power shift with high-low range. The transmission shifts to automatic drive when the D range is engaged in the high mode.

Gear ratios (forward and reverse):

Lower mode: 1st-5.045; 2nd-2.991; 3rd-1.70; R-5.045

High mode: 1st-2.354; 2nd-1.395; 3rd-0.793; R-2.354

BRAKES

Service: Air-over hydraulic disc brakes on all wheels; dual caliper on both front wheels and rear wheels.

Parking: Spring-applied, air-released shoe brake on the out-put shaft of the transmission, and complementary disc brake actuator.



STEERING

"Orbitrol" hydraulic steering with emergency system. Four steering modes are provided: normal, cramp, crab, and rear. Adjustable steering wheel. About-Face Steering Compensator

An about-face steering compensator makes it possible to travel in reverse with the same handling characteristics as forward travel. The compensator is activated by a reverse steer switch on the front panel.

SUSPENSION

Front and rear axles are fitted with torque rod and hydro-pneumatic suspension with lock-up system.

FRONT/REAR AXLES

Fully floating drive-steer type axles. Standard conventional differential on all axle.

AXLE LOADINGS

Gross-Vehicle Weight: 37,460kg; (37,570kg with operator)

Front: 18,720kg; (18,785kg with operator)

Rear: 18,740kg; (18,785kg with operator)

FINAL REDUCTION

2-stage reduction with a ratio of 16,942

(Differential=3.7; final reduction=4.579)

TIRES

Front/Rear: 18.00R25**(OR)

LIGHTS

Halogen headlights, license plate light, clearance light, stop lights, directional lights, parking lights, back light, step light.

ATTACHMENTS

BOOM

Boom consists of a boom base and four power telescoping sections. The first and second sections are paired and extent simultaneously, as do the third and tip sections synchronized. All-welded, high tensile strength steel box construction.

Fully retracted length 10.2m

Fully extended length 39.0m

JIB

9m "A" frame jib with telescopic box section extendable to "15" m stored alongside of boom. Jib swing down under the boom and twisted to set out. Jib offsets 5°, 17°, and 30° with suspension rods. Optional sky tilt for variable offset angle 5° to 45° operated from the cab.

Length 9.0m/15.0m

AUXILIARY SHEAVE

The pin-released auxiliary sheave permits one-part line operation.



HOOK BLOCKS

Five-sheave, 45 metric ton block with safety latch.

3-sheave, 21 metric ton block with safety latch.

4.5 metric ton ball hook with swivel and safety latch.

PERFORMANCE

Max. rated lifting capacity: 45.0 metric tonx3.0m

Boom length: 10.20 to 39.0m

Twist jib length: 9.0m/15.0m

Boom derricking angle: 0 to 82.5°

Boom derricking time: 60 sec

Boom telescoping time: 120 sec (10.20 to 39.0m)

Main hoist line speed (4th layer) High: 122m/min

Low: 52m/min

Aux. hoist hook speed (2nd layer) High: 105m/min

Low: 45m/min

Swing speed: 2.4rpm

Max. travel speed: 49km/h

Gradeability: tanθ0.6

Note: Please consult your local dealer for details concerning which features are standard and which are optional.

Lifting Capacities

NOTES FOR LIFTING CAPACITIES

GENERAL NOTES

- Lifting capacities listed apply only to the machine as originally manufactured and designed by KOBE STEEL, LTD. modifications to this machine or use of equipment other than that specified can reduce operating capacity.
- Construction equipment can be dangerous if improperly operated or maintained. Operation and maintenance of this machine must be in compliance with the information in the operation, safety and maintenance manual supplied with machine. If this manual is missing, order replacement through the distributor.

OPERATION WITH OUTRIGGERS

- For outrigger operation, outriggers shall be fully extended with tires free of supporting surface before operating crane.
 - Total rated loads shown on the chart are the maximum allowable crane capacities and are based on the machine standing level on firm supporting surface under ideal job conditions. Depending on the nature of the supporting surface, it may be necessary to have structural supports under the outrigger floats to spread the load to larger bearing surface.
 - Capacities do not exceed 78% of the tipping loads. Capacities based on factors other than machine stability such as structural competence are shown in bold lines.
- Weight of hooks, hook blocks, slings and other lifting devices are a part of the total load. Their total weight must be subtracted from the rated load to obtain the weight that can be lifted.
- 45-ton hook block weight 370kg
 21-ton hook block weight 230kg
 4.5-ton hook block weight 90kg
- The working radius given in the charts allow for loaded boom deflection. Always operate the machine on the basis of actual operating radius.
 - Total rated loads are based on freely suspended loads and make no allowance for such factors as the effect of wind, sudden stopping of loads, supporting surface conditions, side loads, etc. Side pull on boom or jib is extremely dangerous.
 - Maximum outrigger extension is 7.2m. Two intermediate extension positions are also provided at 5.4m and 4.0m. Minimum outrigger extension is 2.49m. Over-the-side ratings depend on outrigger extension. Values for each outrigger position are given separately and must be followed accordingly during operation. Load rating over the front and rear assume fully extended outrigger position.

Over-the-front area

Over-the-rear area

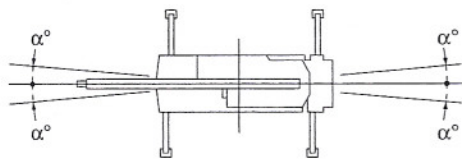

Outriggers	5.4m extension	4.0m extension	2.49m extension (only H type)
α° (FRONT)	28	20	5
α° (REAR)	28	20	5

- Ratings of the auxiliary sheave should not exceed 4,500kg. For boom length between 10.2m and 17.4m, deduct the weight of 45-ton hook block (4,500kg) from the main boom rating. For boom length longer than 17.4m, deduct the 20-ton hook block (230kg).
- To determine load ratings that fall between those shown in the charts, proceed as follows:
 - For boom lengths not listed use rating for next longer boom length or next shorter boom length, whichever smaller.
 - For load radii not shown, use rating for next larger radius.
- Total load that can be lifted over a jib is based on main boom angle only.

- When lifting over the boom with a jib extended, deduct the weight of the hook block, other handling accessories, and 1,800kg (with jib box section stored) or 2,100kg (extended) from the main boom ratings. Do not use the auxiliary sheave when the jib is extended.
- To attempt to lift loads in the area other than those listed in the rated load charts, the machine may tip or collapse.
- Standard hoist reevings are shown below. Rated single-line pull is 4,500kg.

Boom length	10.2m	17.4m	24.6m	31.8m	39.0m	Aux. sheave
Hook	45-ton	45-ton	21-ton	21-ton	21-ton	4.5-ton
Parts of line	10	6	5	3	2	1

- Free fall should in principle be done with no load on a hook. When a load must unavoidably be applied, load allowable for free fall operations are restricted to one-fifth of rated loads at the given load radius. Never brake suddenly during free fall, or machine may tip.

OPERATION WITHOUT OUTRIGGERS (ON TIRES)

- Load ratings are the allowable maximum lifting capacities for a firm and level surface, with tires filled to prescribed pressure (8.00kg/cm²), and with axle lock-out cylinder engaged. Damaged tires are hazardous to safe operation of crane. Ratings include hook block and all other load handling accessories. Values in the bold lines are based on the machine's hydraulic or structural limitations; all others are based on stability.
 - 45-ton hook block weight 370kg
 - 21-ton hook block weight 230kg
 - 4-ton hook block weight 90kg
- The working radius given in the charts allow for loaded boom deflection. Always operate the machine on the basis of actual operating radius.
- Load ratings differ for over-the-front and 360° operation. Care must be taken to avoid overload when swinging a load from an over-the-front position to a over-the-side position.

Over-the-front area

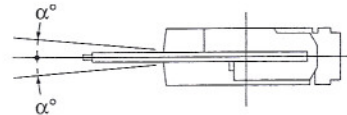

On tires	Stationary	Pick & carry
α° (FRONT)	1°	1°

- Ratings of the auxiliary sheave should not exceed 4,500kg. For boom length between 10.2m and 17.4m, deduct the weight of 45-ton hook block (4,500kg) from the main boom rating. For boom length longer than 17.4m, deduct the 20-ton hook block (230kg).
- Do not operate the jib or use free fall.
- Parking brake and auxiliary brake must be applied during stationary load lifting.
- Pick and carry operations must be done in the low travel mode.
- During pick and carry operations, keep the load close to the ground to avoid swaying, and travel no faster than 2.0km/h. Avoid cornering, sudden starts, sudden acceleration, and sudden braking. Boom must be centered over the front area.
- Do not operate the crane functions while carrying the load.
- Standard hoist reevings are shown below. Single-line load must not exceed 4,500kg.

Boom length	10.2m	17.4m	24.6m	Aux. sheave
Hook	45-ton	45-ton	21-ton	4.5-ton
Parts for line	10	6	5	1

Main Boom Lifting Capacities with Outriggers

Operating radius in meters	With outriggers 7.2m extended—360° working area					With outriggers in 5.4m position—over the side					With outriggers in 4.0m position—over the side					With outriggers in 2.57m position over the side		
	Boom length in meters					Boom length in meters					Boom length in meters					Boom length in meters		
	10.2	17.4	24.6	31.8	39.0	10.2	17.4	24.6	31.8	39.0	10.2	17.4	24.6	31.8	39.0	10.2	17.4	24.6
3.0	45.00	28.00	20.00			45.00	28.00	20.00			40.00	28.00	20.00			15.00	12.00	11.00
3.5	40.80	28.00	20.00	13.00		40.80	28.00	20.00	13.00		33.20	28.00	20.00	13.00		15.00	12.00	11.00
3.75	38.90	28.00	20.00	13.00		38.90	28.00	20.00	13.00		30.00	28.00	20.00	13.00		15.00	12.00	11.00
4.0	37.00	28.00	20.00	13.00		37.00	28.00	20.00	13.00		27.00	25.30	20.00	13.00		13.60	12.00	11.00
4.5	33.50	28.00	20.00	13.00	7.50	33.50	28.00	20.00	13.00	7.50	21.60	21.15	20.00	13.00	7.50	11.00	10.50	9.80
5.0	30.20	28.00	20.00	13.00	7.50	28.20	24.90	20.00	13.00	7.50	17.80	17.30	16.70	13.00	7.50	9.10	8.70	8.65
5.5	27.50	25.70	20.00	13.00	7.50	24.20	22.50	20.00	13.00	7.50	15.00	14.40	14.10	13.00	7.50	7.65	7.30	7.20
6.0	25.00	23.60	20.00	13.00	7.50	20.80	20.50	18.25	13.00	7.50	12.80	12.20	12.05	13.00	7.50	6.45	6.20	6.10
6.5	22.70	21.80	18.50	13.00	7.50	18.00	17.40	16.65	13.00	7.50	11.10	10.60	10.35	11.50	7.50	5.50	5.25	5.15
7.0	20.70	20.20	17.10	13.00	7.50	15.40	15.00	15.00	13.00	7.50	9.65	9.30	9.00	10.20	7.50	4.70	4.50	4.40
7.2	11.50	19.60	16.60	13.00	7.50	11.50	14.25	14.20	13.00	7.50	9.15	8.80	8.50	9.70	7.50	4.40	4.20	4.10
7.5		18.70	16.00	13.00	7.50		13.30	13.10	13.00	7.50		8.10	7.85	9.00	7.50		3.85	3.75
8.0		17.40	15.00	12.35	7.50		11.70	11.50	12.00	7.50		7.15	6.90	8.00	7.50		3.30	3.20
8.5		16.20	14.10	11.70	7.50		10.40	10.20	11.00	7.50		6.30	6.10	7.10	7.05		2.80	2.65
9.0		15.00	13.30	11.15	7.50		9.30	9.10	10.00	7.50		5.60	5.40	6.40	6.60		2.35	2.20
9.5		13.80	12.60	10.60	7.50		8.40	8.15	9.10	7.50		5.00	4.80	5.75	6.20		1.90	1.75
10.0		12.45	12.00	10.10	7.50		7.55	7.30	8.30	7.50		4.45	4.25	5.20	5.70		1.50	1.40
11.0		10.30	10.15	9.20	7.00		6.20	6.00	6.90	6.75		3.50	3.25	4.25	4.75		0.85	0.70
12.0		8.65	8.50	8.40	6.50		5.15	4.90	5.80	6.05		2.70	2.45	3.45	4.00			
13.0		7.35	7.20	7.70	6.05		4.25	4.00	4.90	5.40		2.00	1.80	2.80	3.35			
14.0		6.30	6.15	7.00	5.65		3.45	3.25	4.20	4.75		1.40	1.25	2.20	2.80			
14.4		4.00	5.75	6.60	5.50		3.20	3.00	3.95	4.50		1.20	1.05	2.00	2.60			
15.0			5.30	6.10	5.25			2.60	3.60	4.15			0.75	1.70	2.30			
16.0			4.55	5.40	4.90			2.05	3.05	3.60				1.25	1.85			
17.0			3.95	4.75	4.55			1.60	2.55	3.15				0.90	1.50			
18.0			3.40	4.20	4.20			1.15	2.10	2.75				0.60	1.15			
19.0			2.90	3.70	3.90			0.80	1.70	2.40					0.85			
20.0			2.40	3.30	3.60				1.35	2.05					0.60			
21.0			2.00	2.90	3.30				1.05	1.75								
21.6			1.80	2.65	3.15				0.90	1.55								
22.0				2.50	3.00				0.80	1.45								
23.0				2.20	2.70				0.55	1.20								
24.0				1.90	2.40					0.95								
25.0				1.60	2.15					0.75								
26.0				1.35	1.90					0.55								
27.0				1.10	1.65													
28.0				0.90	1.45													
28.8				0.80	1.30													
29.0					1.25													
30.0					1.05													
31.0					0.90													
32.0					0.75													
33.0					0.60													
Min. angle	0°	0°	0°	0°	0°	0°	0°	28°	36°	43°	0°	0°	45°	50°	55°	0°	39°	57°

*H-typhe only

Main Boom Lifting Capacities without Outriggers

Operating radius in meters	Stationary						Pick & Carry (under 2km/h)					
	360° working area			Over the front			360° working area			Over the front		
	Boom length in meters			Boom length in meters			Boom length in meters			Boom length in meters		
	10.2	17.4	24.6	10.2	17.4	24.6	10.2	17.4	24.6	10.2	17.4	24.6
3.0	12.50	10.00	5.50	20.00	15.00	10.50	8.00	6.50	4.50	14.50	10.50	8.00
3.5	9.10	8.00	5.50	20.00	15.00	10.50	8.00	6.50	4.50	14.50	10.50	8.00
3.75	8.05	7.20	5.50	20.00	15.00	10.50	8.00	6.50	4.50	14.50	10.50	8.00
4.0	7.20	6.50	5.50	20.00	15.00	10.50	7.20	6.50	4.50	14.50	10.50	8.00
4.5	5.70	5.25	5.50	17.40	15.00	10.50	5.70	5.25	4.50	12.50	10.50	8.00
5.0	4.50	4.20	4.20	15.10	15.00	10.50	4.50	4.20	4.20	11.00	10.50	8.00
5.5	3.60	3.25	3.25	13.66	13.70	10.50	3.60	3.25	3.25	9.90	10.50	8.00
6.0	2.80	2.55	2.45	12.20	12.40	10.50	2.80	2.55	2.45	8.95	9.50	8.00
6.5	2.20	1.95	1.85	11.20	11.30	9.50	2.20	1.95	1.85	8.25	8.60	8.00
7.0	1.70	1.45	1.35	10.30	10.20	8.70	1.70	1.45	1.35	7.60	7.80	7.25
7.2	1.50	1.25	1.15	10.00	9.75	8.35	1.50	1.25	1.15	7.35	7.45	7.00
7.5		1.05	0.95		9.10	7.90		1.05	0.95		7.00	6.65
8.0		0.70	0.65		8.10	7.20		0.70	0.65		6.35	6.05
8.5					7.20	6.55					5.80	5.50
9.0					6.40	5.90					5.25	5.00
9.5					5.75	5.40					4.75	4.55
10.0					5.20	4.80					4.30	4.10
11.0					4.30	3.90					3.60	3.30
12.0					3.60	3.20					3.00	2.75
13.0					3.00	2.65					2.40	2.25
14.0					2.40	2.15					1.90	1.80
14.4					2.20	1.95					1.70	1.65
15.0						1.70						1.40
16.0						1.30						1.05
17.0						0.90						0.75
Min. angle	0°	54°	65°	0°	0°	37°	0°	54°	65°	0°	0°	37°

Standard Jib Lifting Capacities with Outriggers

Main boom angle	With outriggers in 7.2m position—360° working area					
	9.0 m jib			15.0 m jib		
	Offset angle			Offset angle		
	5°	17°	30°	5°	17°	30°
82	3.50	2.80	2.20	2.40	1.60	1.10
80	3.50	2.80	2.20	2.40	1.60	1.10
78	3.50	2.80	2.20	2.40	1.60	1.10
77	3.50	2.80	2.20	2.32	1.60	1.10
76	3.50	2.80	2.20	2.23	1.60	1.10
75	3.50	2.80	2.20	2.15	1.60	1.10
74	3.32	2.68	2.11	2.06	1.53	1.08
72	3.00	2.45	1.96	1.91	1.41	1.04
70	2.75	2.24	1.82	1.76	1.32	1.00
68	2.52	2.05	1.71	1.63	1.25	0.96
66	2.30	1.91	1.62	1.51	1.18	0.92
64	2.12	1.80	1.53	1.41	1.13	0.89
62	1.96	1.69	1.46	1.33	1.08	0.86
60	1.85	1.60	1.39	1.25	1.04	0.84
58	1.74	1.50	1.32	1.19	0.99	0.81
57	1.70	1.45	1.29	1.16	0.97	0.79
56	1.62	1.41	1.26	1.14	0.95	0.78
55	1.49	1.37	1.23	1.11	0.93	0.76
54	1.35	1.27	1.20	1.06	0.90	0.75
53	1.22	1.14	1.07	0.95	0.88	0.74
52	1.10	1.03	0.96	0.84	0.79	0.71
51	0.99	0.92	0.86	0.74	0.70	0.63
50	0.88	0.81	0.77	0.66	0.61	0.55
48	0.67	0.63	0.60	0.48	0.44	0.41
47	0.58	0.53	0.52	0.41	0.38	0.35
46	0.50	0.45	0.43	0.35		
45	0.42	0.37	0.35			
44	0.34					
Min. angle	44°	45°	45°	46°	47°	47°

Main boom angle	With outriggers in 5.4m position—over the side					
	9.0 m jib			15.0 m jib		
	Offset angle			Offset angle		
	5°	17°	30°	5°	17°	30°
82	3.50	2.80	2.20	2.40	1.60	1.10
80	3.50	2.80	2.20	2.40	1.60	1.10
78	3.50	2.80	2.20	2.40	1.60	1.10
77	3.50	2.80	2.20	2.32	1.60	1.10
76	3.50	2.80	2.20	2.23	1.60	1.10
75	3.50	2.80	2.20	2.15	1.60	1.10
74	3.32	2.68	2.11	2.06	1.53	1.08
72	3.00	2.45	1.96	1.91	1.41	1.04
70	2.75	2.24	1.82	1.76	1.32	1.00
68	2.52	2.05	1.71	1.63	1.25	0.96
67	2.26	1.98	1.66	1.57	1.22	0.94
66	2.03	1.80	1.62	1.51	1.18	0.92
65	1.80	1.64	1.58	1.46	1.16	0.90
64	1.60	1.48	1.40	1.31	1.13	0.89
63	1.41	1.31	1.23	1.13	0.97	0.88
62	1.24	1.15	1.07	0.98	0.83	0.74
60	0.91	0.85	0.77	0.72	0.58	0.52
58	0.64	0.57	0.50	0.47	0.38	0.33
57	0.50	0.44	0.39	0.36		
56	0.40	0.31				
Min. angle	56°	56°	57°	57°	58°	58°

Main boom angle	With outriggers in 4.0m position—over the side					
	9.0 m jib			15.0 m jib		
	Offset angle			Offset angle		
	5°	17°	30°	5°	17°	30°
82	3.50	2.80	2.20	2.40	1.60	1.10
80	3.50	2.80	2.20	2.40	1.60	1.10
78	3.50	2.80	2.20	2.40	1.60	1.10
77	3.50	2.80	2.20	2.32	1.60	1.10
76	3.50	2.80	2.20	2.23	1.60	1.10
75	3.50	2.80	2.20	2.15	1.60	1.10
74	2.84	2.40	2.11	2.06	1.53	1.08
73	2.40	2.09	1.80	1.98	1.46	1.06
72	2.02	1.80	1.53	1.76	1.41	1.04
71	1.76	1.53	1.29	1.46	1.15	1.02
70	1.42	1.28	1.08	1.20	0.96	0.88
69	1.17	1.04	0.89	0.96	0.79	0.73
68	0.94	0.82	0.73	0.75	0.62	0.58
67	0.74	0.62	0.56	0.57	0.46	0.43
66	0.56	0.44	0.41	0.40	0.32	0.30
65	0.40					
Min. angle	65°	66°	66°	66°	66°	66°

Working Ranges

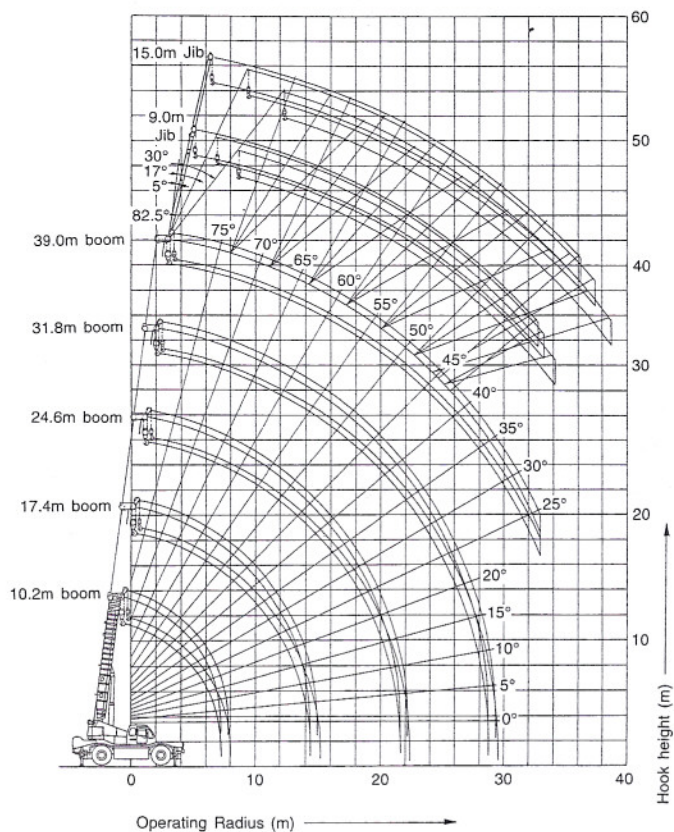

Ratings inside the bold lines are governed by the strength of the boom or other structural components.

Optional Sky Tilt jib Lifting Capacities with Outriggers

Main boom angle	With outriggers in 7.2m position—360° working area					
	9.0 m jib			15.0 m jib		
	Offset angle			Offset angle		
	5°	25°	45°	5°	25°	45°
82	3.50	2.40	1.60	2.40	1.25	0.80
80	3.50	2.40	1.60	2.40	1.25	0.80
78	3.50	2.40	1.60	2.40	1.25	0.80
77	3.50	2.40	1.60	2.32	1.25	0.80
76	3.50	2.40	1.60	2.23	1.22	0.80
75	3.50	2.31	1.60	2.15	1.20	0.80
74	3.32	2.23	1.58	2.06	1.18	0.79
72	3.00	2.08	1.54	1.91	1.14	0.79
70	2.75	1.95	1.50	1.76	1.10	0.78
68	2.52	1.84	1.45	1.63	1.06	0.77
66	2.30	1.72	1.39	1.51	1.02	0.76
64	2.12	1.60	1.35	1.41	0.99	0.75
62	1.96	1.52	1.31	1.33	0.95	0.74
60	1.85	1.45	1.26	1.25	0.92	0.73
58	1.74	1.37	1.22	1.19	0.88	0.72
57	1.70	1.34	1.20	1.16	0.86	0.72
56	1.62	1.30	1.17	1.14	0.84	0.71
55	1.49	1.27	1.14	1.11	0.82	0.71
54	1.35	1.21	1.12	1.06	0.80	0.70
53	1.22	1.10	1.02	0.95	0.78	0.70
52	1.10	1.00	0.94	0.84	0.72	0.69
51	0.99	0.90	0.85	0.74	0.64	0.62
50	0.88	0.80	0.76	0.66	0.57	0.54
48	0.67	0.62	0.59	0.48	0.43	0.40
47	0.58	0.52	0.50	0.41	0.37	0.34
46	0.50	0.44	0.42	0.35	0.32	
45	0.42	0.36	0.34			
44	0.34					
Min. angle	44°	45°	45°	46°	46°	47°

Main boom angle	With outriggers in 5.4m position—over the side					
	9.0 m jib			15.0 m jib		
	Offset angle			Offset angle		
	5°	25°	45°	5°	25°	45°
82	3.50	2.40	1.60	2.40	1.25	0.80
80	3.50	2.40	1.60	2.40	1.25	0.80
78	3.50	2.40	1.60	2.40	1.25	0.80
77	3.50	2.40	1.60	2.32	1.25	0.80
76	3.50	2.40	1.60	2.23	1.22	0.80
75	3.50	2.31	1.60	2.15	1.20	0.80
74	3.32	2.23	1.58	2.06	1.18	0.79
72	3.00	2.08	1.54	1.91	1.14	0.79
70	2.75	1.95	1.50	1.76	1.10	0.78
68	2.52	1.84	1.45	1.63	1.06	0.77
67	2.26	1.78	1.42	1.57	1.04	0.76
66	2.03	1.72	1.39	1.51	1.02	0.76
65	1.80	1.66	1.37	1.46	1.01	0.75
64	1.60	1.47	1.35	1.31	0.99	0.75
63	1.41	1.29	1.19	1.13	0.89	0.74
62	1.24	1.12	1.03	0.98	0.77	0.68
60	0.91	0.81	0.75	0.72	0.56	0.48
58	0.64	0.52	0.49	0.47	0.34	0.30
57	0.50	0.40	0.38	0.36		
56	0.40					
Min. angle	56°	57°	57°	57°	58°	58°

Main boom angle	With outriggers in 4.0m position—over the side					
	9.0 m jib			15.0 m jib		
	Offset angle			Offset angle		
	5°	25°	45°	5°	25°	45°
82	3.50	2.40	1.60	2.40	1.25	0.80
80	3.50	2.40	1.60	2.40	1.25	0.80
78	3.50	2.40	1.60	2.40	1.25	0.80
77	3.50	2.40	1.60	2.32	1.25	0.80
76	3.50	2.40	1.60	2.23	1.22	0.80
75	3.50	2.31	1.60	2.15	1.20	0.80
74	2.84	2.23	1.58	2.06	1.18	0.79
73	2.40	1.92	1.56	1.98	1.16	0.79
72	2.02	1.63	1.36	1.76	1.14	0.79
71	1.70	1.38	1.16	1.46	1.12	0.78
70	1.42	1.16	0.97	1.20	0.95	0.78
69	1.17	0.96	0.80	0.96	0.78	0.64
68	0.94	0.76	0.65	0.75	0.61	0.50
67	0.74	0.59	0.50	0.57	0.45	0.40
66	0.56	0.42	0.36	0.40	0.31	
65	0.40					
Min. angle	65°	66°	66°	66°	66°	67°

Working Ranges

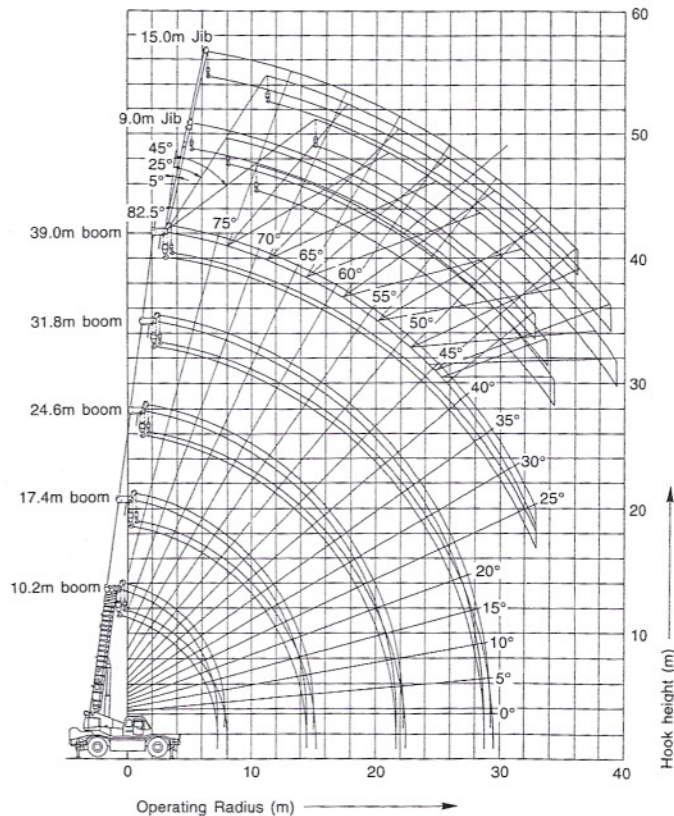

Ratings inside the bold lines are governed by the strength of the boom or other structural components.

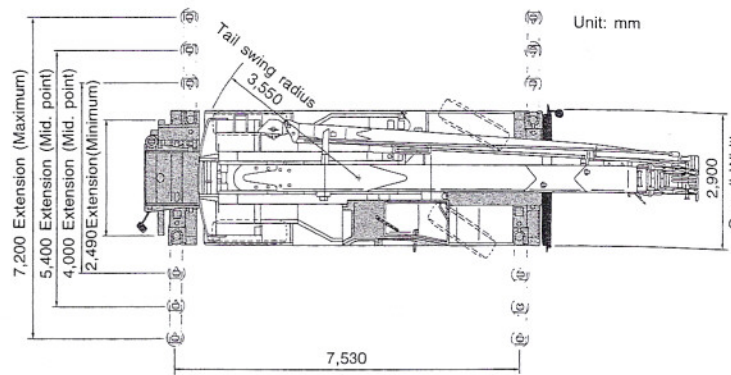
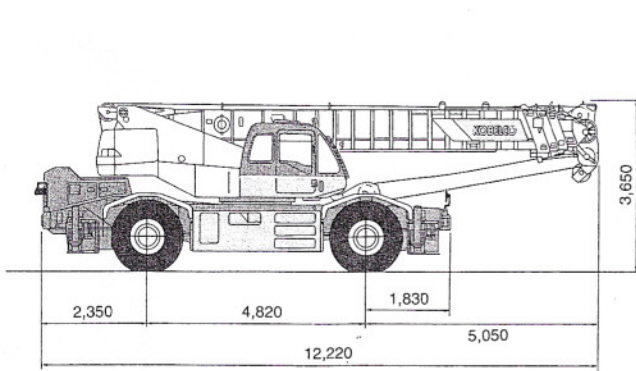

Turning Radius

2-Drive Steering (Front)

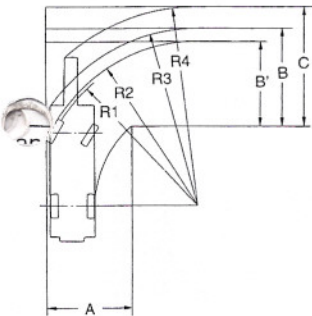

R1	Minimum turning radius	10.60m
R2	Tire clearance with curb	10.89m
R3	Carrier clearance	11.70m
R4	Boom clearance	13.22m
A	Entrance width	5.62m
B	Exit width (carrier)	6.43m
B'	Exit width (tires)	5.62m
C	Exit width (boom)	7.95m

4-Drive Steering

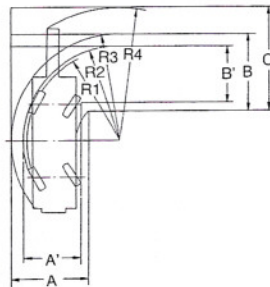

R1	Minimum turning radius	5.94m
R2	Tire clearance with curb	6.25m
R3	Carrier clearance	7.07m
R4	Boom clearance	8.86m
A	Entrance width (carrier)	5.07m
A'	Entrance width (tires)	3.73m
B	Exit width (carrier)	5.07m
B'	Exit width (tires)	3.73m
C	Exit width (boom)	6.90m

2-Drive Steering (Rear)

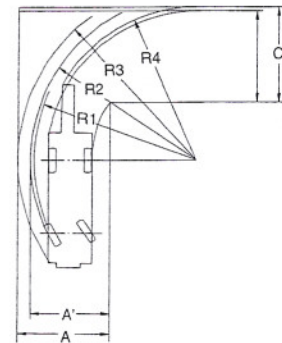

R1	Minimum turning radius	10.60m
R2	Tire clearance with curb	10.89m
R3	Carrier clearance	11.75m
R4	Boom clearance	10.15m
A	Entrance width (carrier)	6.11m
A'	Entrance width (tire)	5.25m
B	Exit width	6.11m
C	Exit width (boom)	6.32m

MASTER COPY
SALES DEPT.

Note: Due to our policy of continual product improvement, all designs and specifications are subject to change without advance notice.

KOBE STEEL, LTD.
ENGINEERING & MACHINERY DIVISION
Construction Machinery Group

27-8, Jingumae 6-chome, Shibuya-ku, TOKYO, 150 Japan/Tel: (03) 3797-7021/Fax: (03) 3797-7072

Bulletin No. RK450-2-SPEC-101

920302TF Printed in Japan