

Technical data
Hydraulic lift crane

LR 1130
Litronic®

Complies with ANSI B 30.5

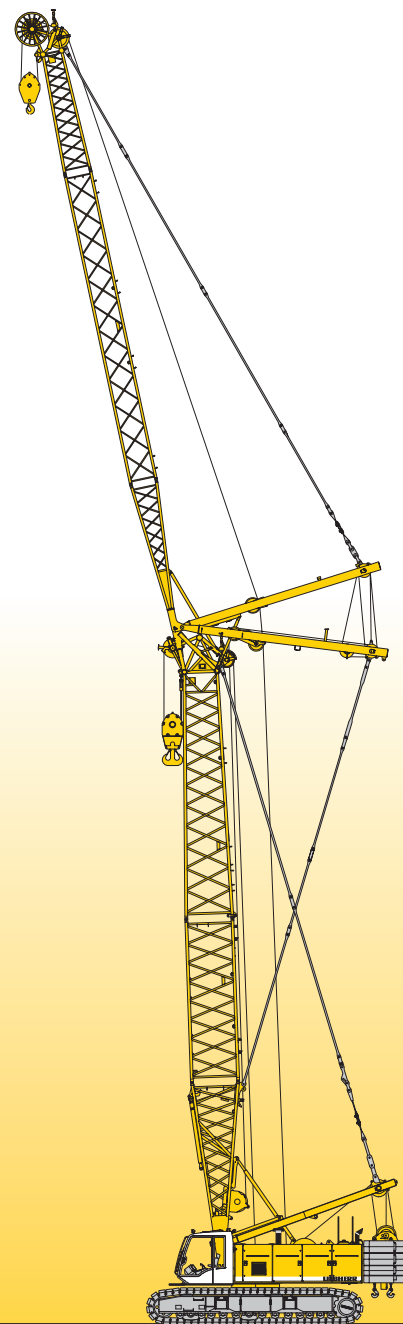

LIEBHERR

Dimensions

Basic machine with undercarriage

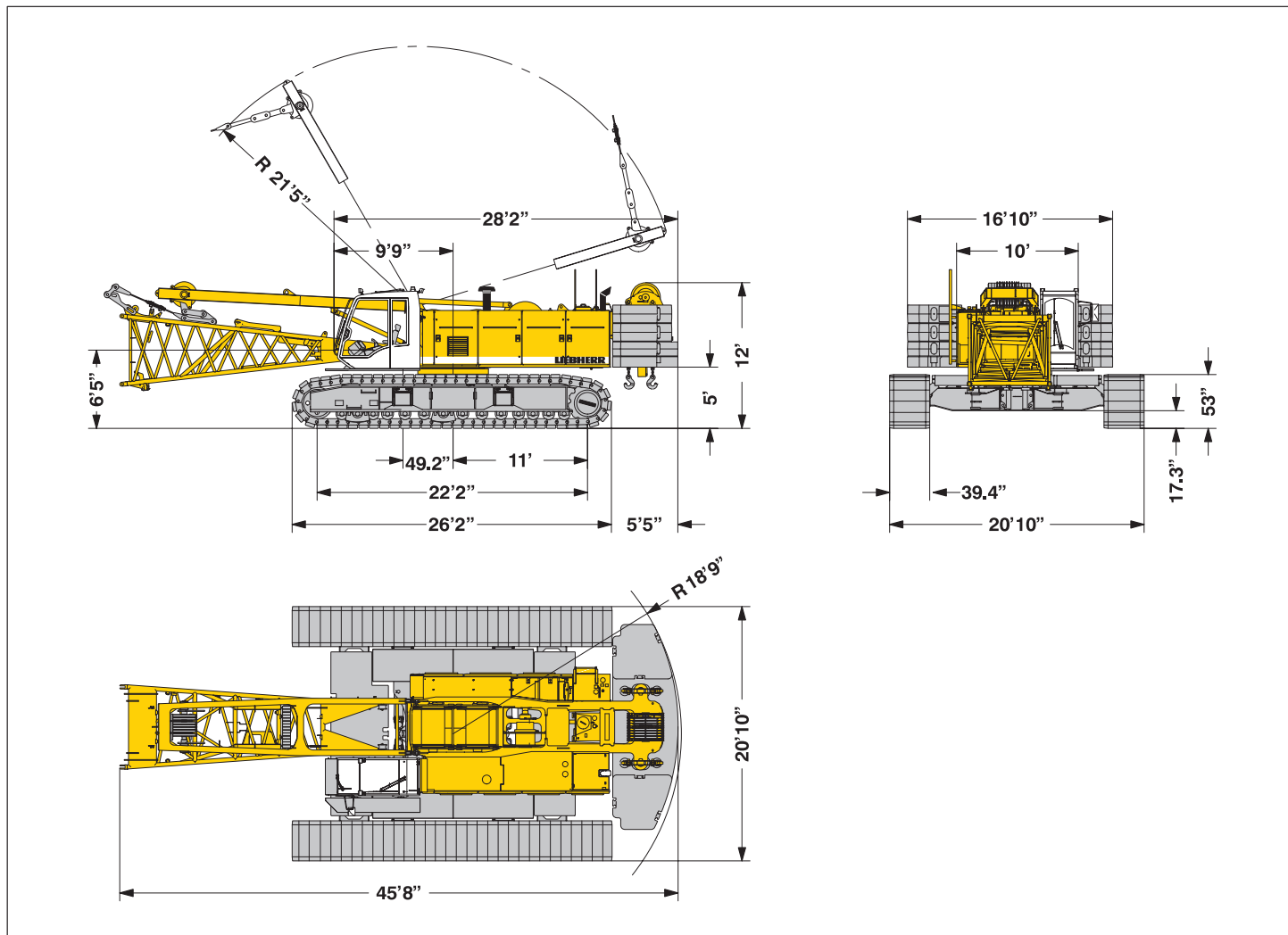

Operating weight

The operating weight includes the basic machine with crawlers, 2 main winches 26,500 lbs and 56 ft main boom, consisting of A-frame, boom foot (23 ft), boom head (33 ft), 112,215 lbs basic counterweight, 44,100 lbs carbony counterweight and 352,750 lbs hook block.

Total weight _____ appr. 322,100 lbs

Ground pressure

Ground bearing pressure _____ 15.4 psi

Equipment

Main boom (No. 2017.xx) max. length _____ 262 ft
 High reach (No. 2017.xx and 1309.xx) _____ 305 ft
 Luffing jib (No. 1309.xx) max. length _____ 258 ft
 Max. combination _____ boom 154 ft and luffing jib 258 ft
 Fixed jib (No. 0806.xx) _____ 36 ft – 105 ft
 Auxiliary jib 53,000 lbs lifting capacity (optional 79,400 lbs)

Remarks

1. The lifting capacities stated are valid for lifting operation only (corresponds with crane classification according to F.E.M. 1.001, crane group A1)
2. Crane standing on firm, horizontal ground.
3. The weight of the lifting device (hoisting ropes, hook block, shackle etc.) must be deducted from the gross lifting capacity to obtain a net lifting value.
4. Additional equipment on boom (e.g. boom walkways, auxiliary jib) must be deducted to get the net lifting capacity.
5. For max. wind speed please refer to lift chart in operator's cab or manual.
6. Working radii are measured from centre of swing and under load.
7. The lifting capacities are valid for 360 degrees of swing.
8. Calculation of stability under load is based on 75% tipping load, ANSI B 30.5 and ISO 4305 Table 2.
9. The structures are calculated according to F.E.M. 1.001 – 1998 (EN 13001-2 / 2004) and tested according to SAE J 987.

Transport dimensions and weights

Basic machine and boom (No.2017.xx)

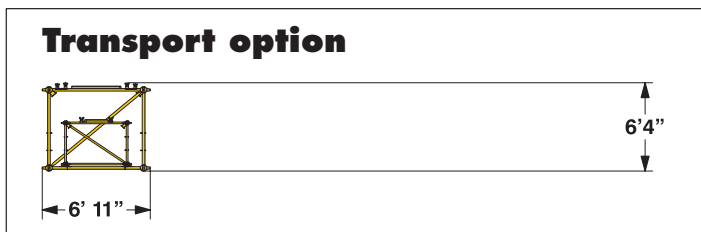
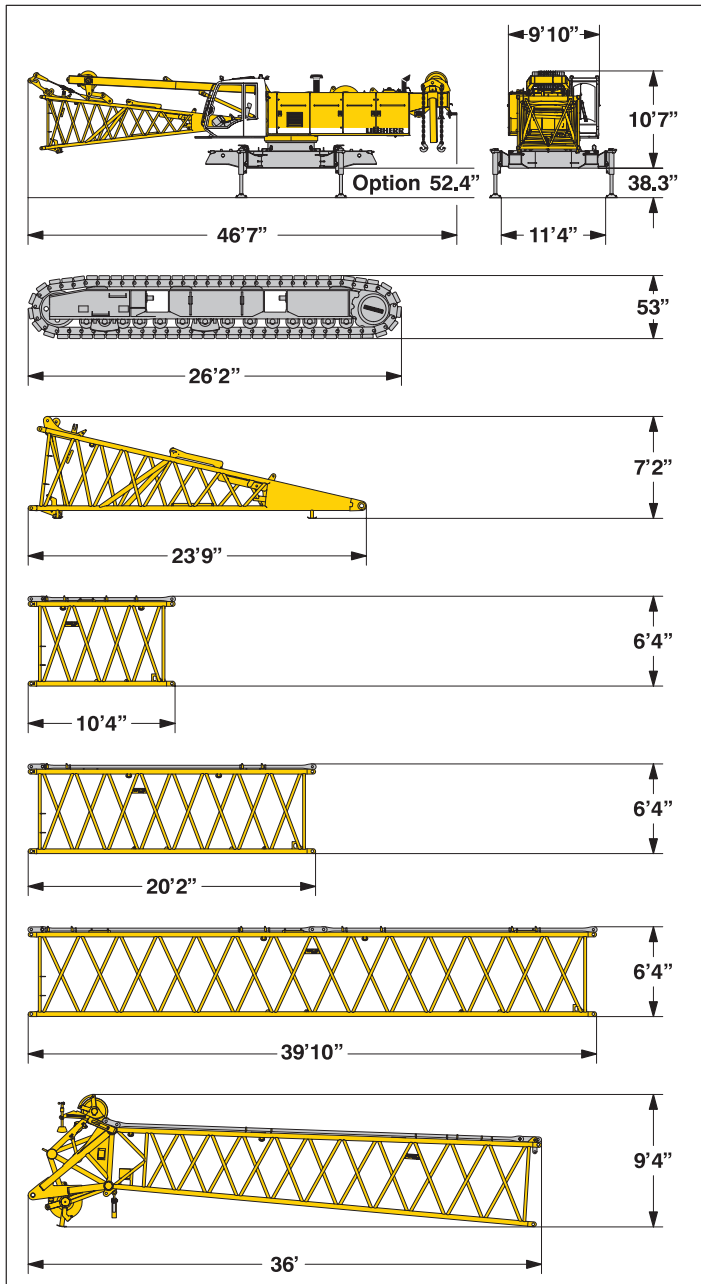

*) Including pendant straps

Basic machine

with A-frame, 2x 26,500 lbs crane winches and boom foot, without hoisting ropes, basic counterweight and crawlers

Width	9'10"
Weight in lbs	73,650

Crawler 2x

Flat track shoes	(option 47.2")	39.4"
Width		55.1"
Weight in lbs		35,300

Boom foot (No. 2017.24) without winches

Width	7'10"
Weight in lbs	5,300

Boom section (No. 2017.21) 10 ft

Width	6'11"
Weight in lbs*	1,450

Boom section (No. 2017.21) 20 ft

Width	6'11"
Weight in lbs*	2,300

Boom section (No. 2017.21) 40 ft

Width	6'11"
Weight in lbs*	4,200

Boom head No. 2017.21)

Width	6'11"
Weight in lbs*	6,950

Boom - luffing jib transport option

40 ft boom – and 38 ft jib extension
20 ft boom – and 20 ft jib extension

(No. 2017.xx/1309.xx)	20 ft/20 ft	40 ft/38 ft
Width	20'1"	40'
Weight in lbs*	3,450	6,300

Transport dimensions and weights

Luffing jib (No. 1309.xx)

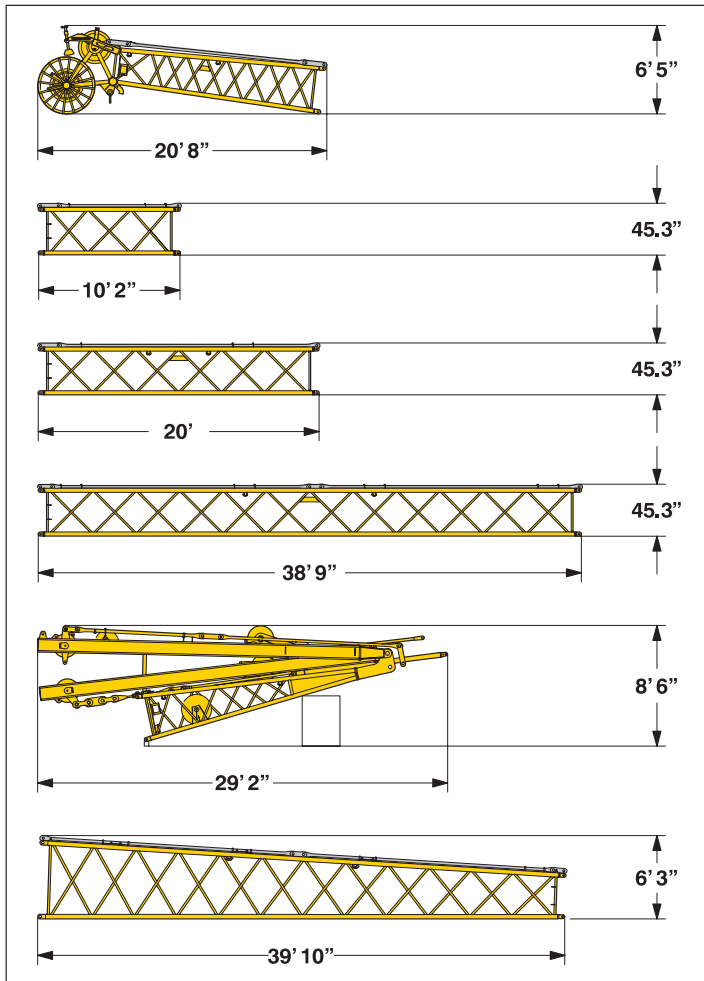

Luffing jib head (No. 1309.22)

Width	59"
Weight in lbs*	2,500

Luffing jib section (No. 1309.20) **10 ft**

Width	59"
Weight in lbs*	930

Luffing jib section (No. 1309.20) **20 ft**

Width	59"
Weight in lbs*	1,150

Luffing jib section (No. 1309.20) **38 ft**

Width	59"
Weight in lbs*	2,120

Luffing jib foot with A-frames (No. 1309.22)

Width	5'7"
Weight in lbs*	10,600

Boom section tapered (No. 2017/1309.21) **40 ft**

Width	6'11"
Weight in lbs*	3,010

Fixed jib (No. 0806.xx)

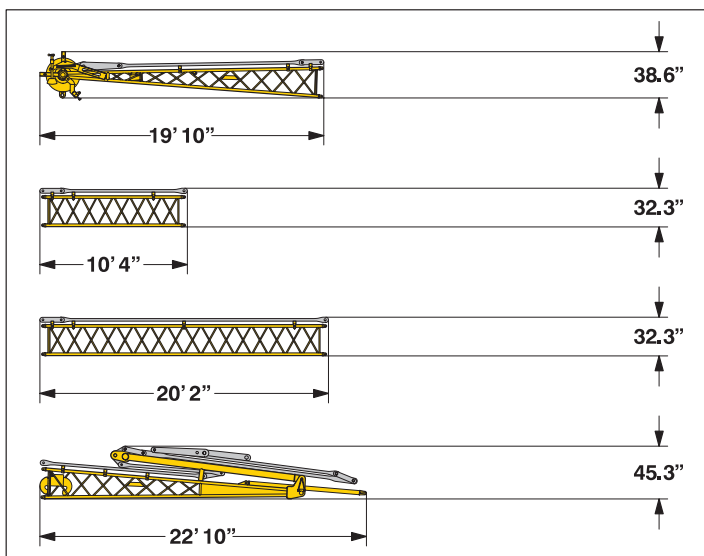

Fixed jib head (No. 0806.16)

Width	45"
Weight in lbs*	985

Fixed jib section (No. 0806.15) **10 ft**

Width	37.4"
Weight in lbs*	245

Fixed jib section (No. 0806.15) **20 ft**

Width	37.4"
Weight in lbs*	430

Fixed jib foot with A-frame (No. 0806.16)

Width	59"
Weight in lbs*	2,050

*) Including pendant straps

Transport dimensions and weights

Counterweights

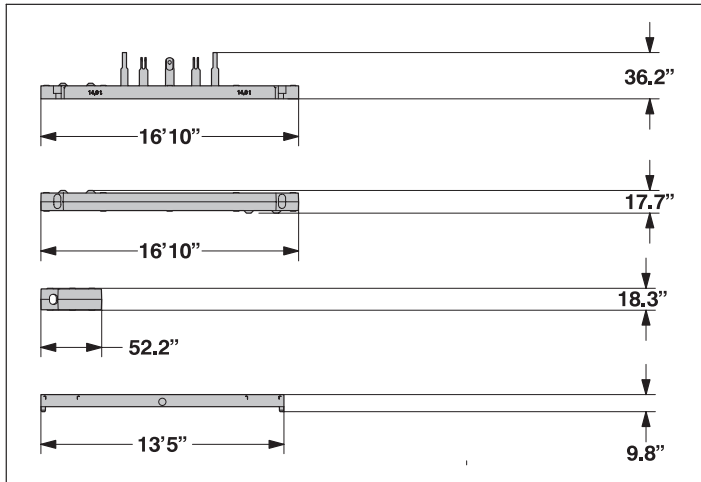

Counterweight	1x
Width	65.4"
Weight in lbs	31,970

Counterweight	1x
Width	65.4"
Weight in lbs	35,935

Counterweight	4x
Width	53.5"
Weight in lbs	11,245

Carbody counterweight	2x
Width	57.1"
Weight in lbs	22,050

Mid fall (option)

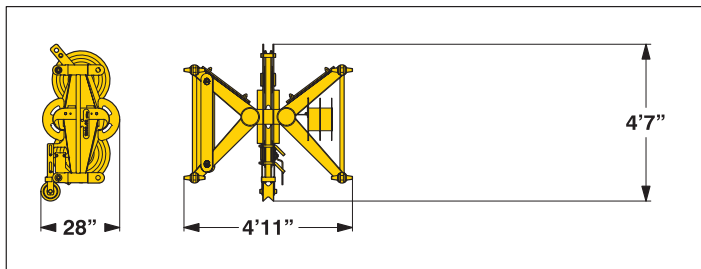

Mid fall section (No. 1309.32)	1.1 ft
Width	28"
Weight in lbs	600

Hooks

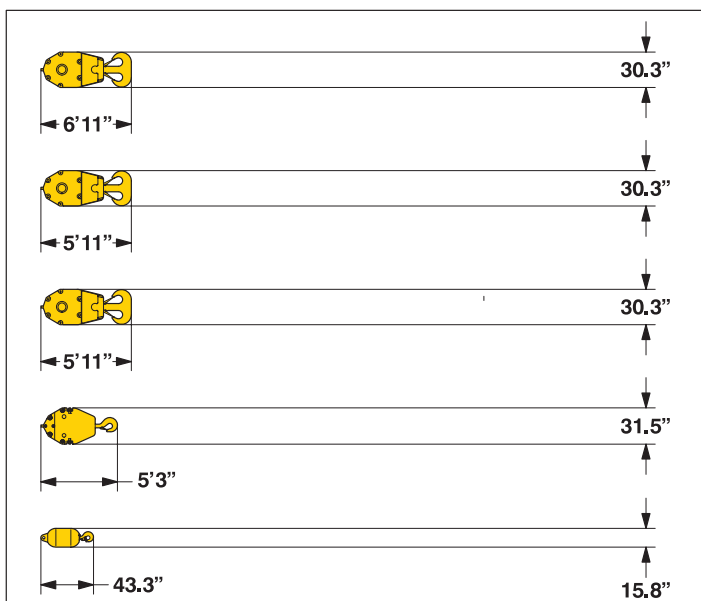

352,750 lbs hook block - 7 sheaves	
Width	25.2" — 30" — 34.6"
Weight in lbs	3,310 — 4,960 — 6,615

220,500 lbs hook block - 5 sheaves	
Width	21.3" — 26.4" — 30.3"
Weight in lbs	2,870 — 3,970 — 5,070

176,400 lbs hook block - 3 sheaves	
Width	14.2 — 18.1 — 22"
Weight in lbs	2,200 — 3,310 — 4,410

88,200 lbs hook block - 1 sheave	
Width	11.8" — 15.8" — 19.7"
Weight in lbs	1,550 — 2,425 — 3,310

27,600 lbs single hook	
Width	15.8"
Weight in lbs	1,330

Technical description



Engine

Power rating according to ISO 9249, 270 kW (362 hp) at 2000 rpm
Engine type _____ Liebherr D 936 L A6
Fuel tank _____ 219 gal capacity with continuous level indicator and reserve warning
Engine complies with NRMM exhaust certification EPA / CARB Tier 3 and 97/68 EC Stage III



Hydraulic system

A double axial displacement pump supplies the open loop hydraulic system, allowing all functions to be operated simultaneously. To minimize peak pressure an automatic working pressure cut-off is integrated in the pump. All filters are electronically monitored.
The use of synthetic environmentally friendly (biodegradable) oils is possible.
Working pressure _____ max. 5080 PSI
Oil tank capacity _____ 172 gal



Luffing jib winch

Line pull _____ max. 23,150 lbs
Rope diameter _____ 20 mm
Jib luffing _____ 46 sec. from 15° to 78°



Boom winch

Line pull _____ max. 33,100 lbs
Rope diameter _____ 24 mm
Boom up _____ 96 sec. from 15° to 86°



Swing

Consists of rollerbearing with external teeth, swing drive with fixed axial piston hydraulic motor, spring loaded and hydraulically released multi-disc holding brake, planetary gearbox and pinion.
Both swing modes are possible – speed control or free swing.
A multi-disc holding brake acts automatically at zero swing motion.
Swing speed from 0 – 3 rpm continuously variable.



Main winches

Line pull (1st layer) _____ max. 38,600 lbs
Line pull (7th layer) _____ 26,500 lbs
Rope diameter _____ 26 mm
Drum diameter _____ 23 inch
Rope speed ft/min _____ 0 – 446
Rope capacity in 7 layers _____ 1600 ft
The winches are outstanding in their compact design and easy assembly. Propulsion is via a planetary gearbox in an oil bath.
Load support by the hydraulic system; additional safety factor provided by a spring loaded, multi-disc holding brake.
The main winches use pressure controlled, variable flow hydraulic motors. This system features sensors that automatically adjust oil flow to provide max. winch speed depending on load.
Option – winch with freefall system:
Clutch and braking functions on the freefall system are provided by a compact designed, low wear and maintenance free multi-disc brake.



Crawlers

Propulsion through axial piston motor, hydraulically released spring loaded multi-disc brake, crawler tracks, hydraulic chain tensioning device.
Flat track shoes _____ 39.4 inch
Drive speed _____ 0 – 1.3 mph



Control

The control system – developed and manufactured by Liebherr – is designed to withstand extreme environmental conditions such as temperature, vibration and electromagnetic interference and to meet all requirements that are needed in heavy duty crane operation.
Complete machine operating data are shown on a high resolution display. Standard operational information is displayed by means of graphical symbols, fault indications are displayed in plain text (more than 15 languages available).
The cranes are equipped with proportional control for all main movements, which can be carried out simultaneously.
The crane is operated with 2 multi-directional joysticks, the right for winch I and boom, the left for winch II and swing control.
Option:
Bi-directional double T-levers for simultaneous boom and luffing jib operation.
The crawlers are activated by the two central foot pedals. Additionally, hand levers can be attached to the pedals.
Remote control for assembly of counterweight.



Noise emission

Noise emissions correspond with 2000/14/EC directive on noise emission by equipment used outdoors.

Boom combinations

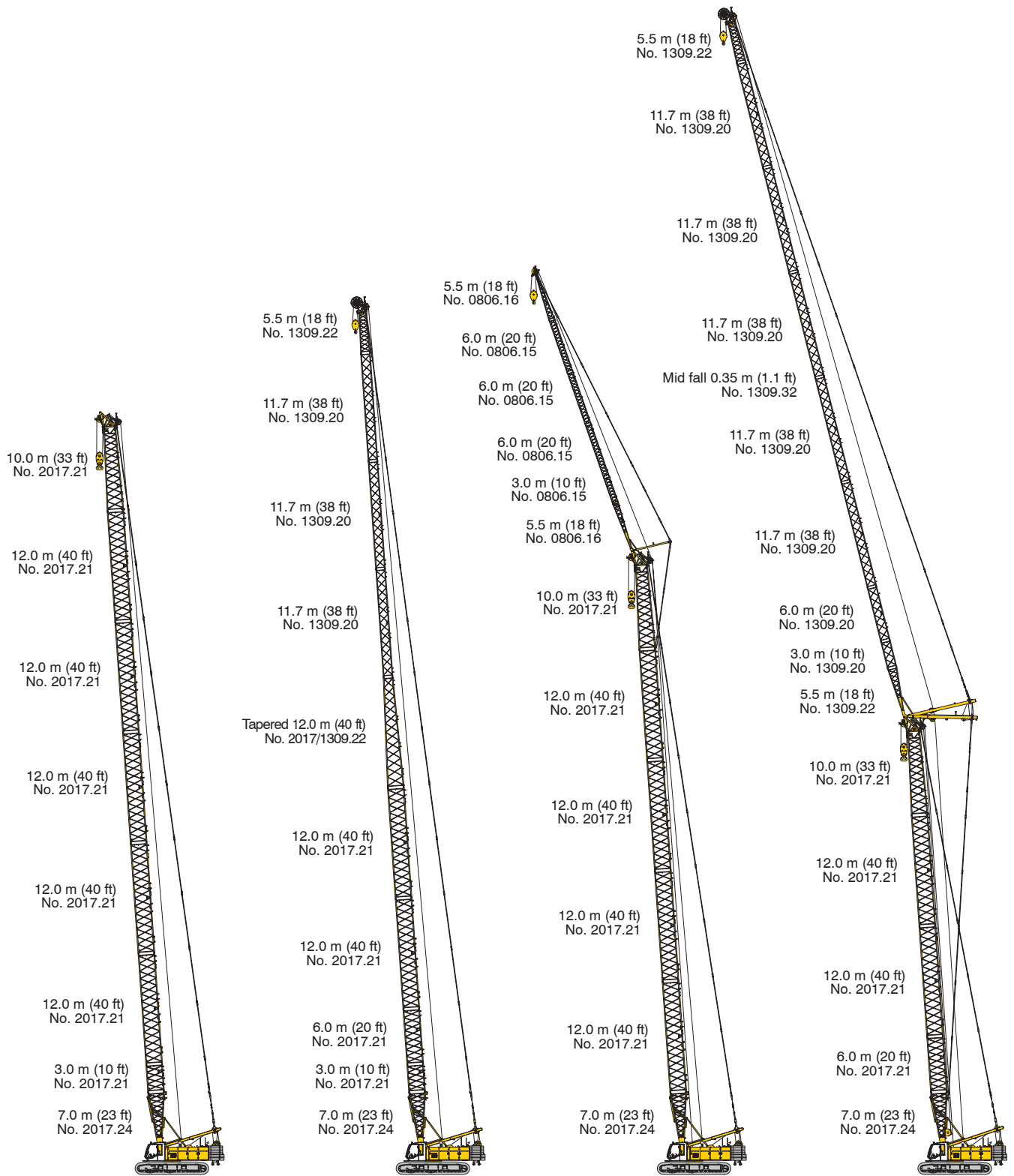

Main boom No. 2017.xx — 262 ft

Max. combination — 305 ft
 Main boom No. 2017.xx — 171 ft
 Tapered No. 2017/1309.xx — 40 ft
 Luffing jib No. 1309.xx — 94 ft

Max. combination — 318 ft
 Main boom No. 2017.xx — 213 ft
 Fixed jib No. 0806.xx — 105 ft
 Main boom No. 2017.xx — 223 ft
 Fixed jib No. 0806.xx — 95 ft

Max. combination — 412 ft
 Main boom No. 2017.xx — 154 ft
 Luffing jib No. 1309.xx — 258 ft
 Main boom No. 2017.xx — 174 ft
 Luffing jib No. 1309.xx — 161 ft

Self assembly system

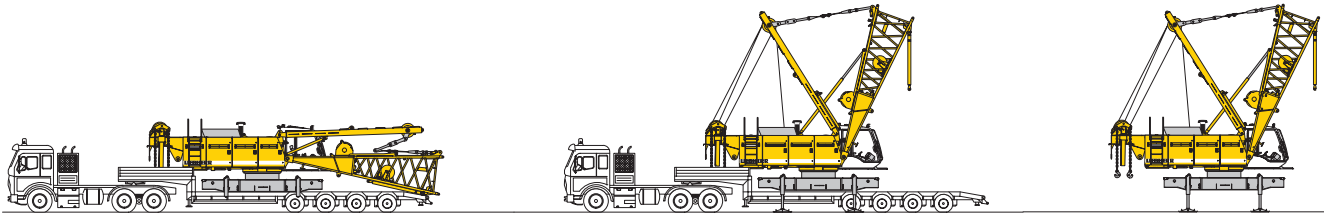

Unloading of basic machine

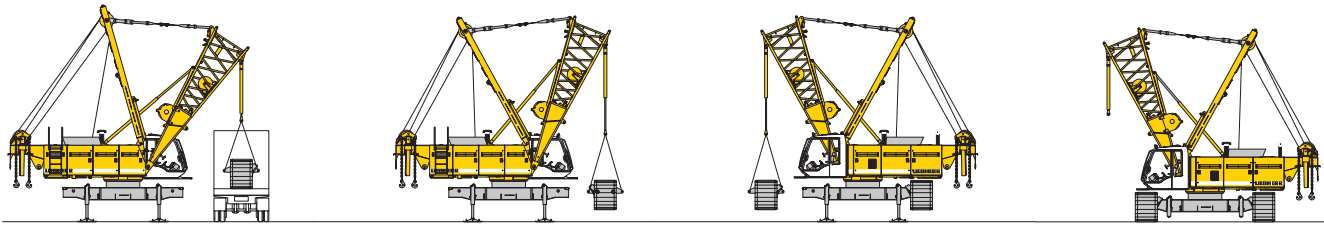

Unloading and assembly of crawlers

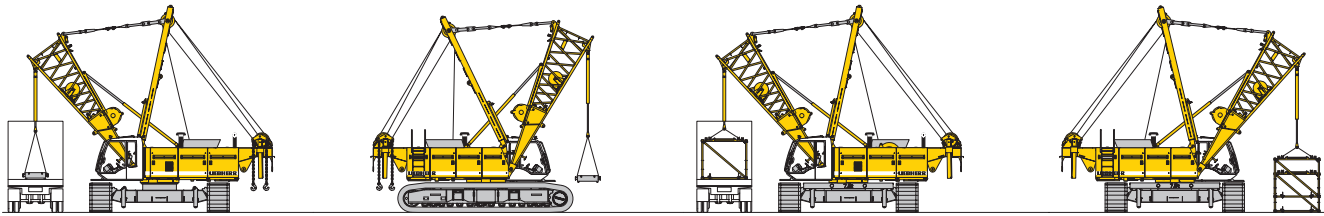

Unloading and assembly of carbody counterweight

Unloading and assembly of boom

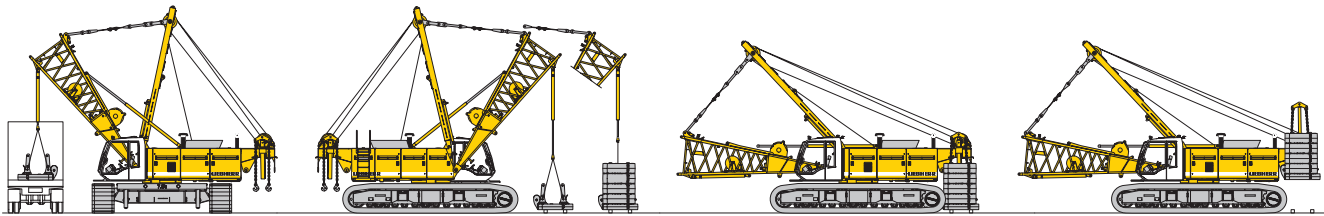

Unloading and assembly of counterweight

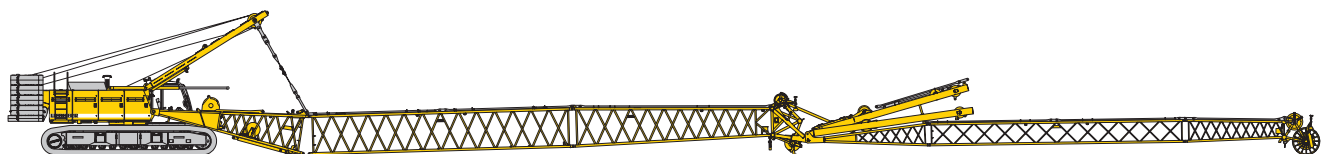

Assembly of boom

Erecting of main boom to working position

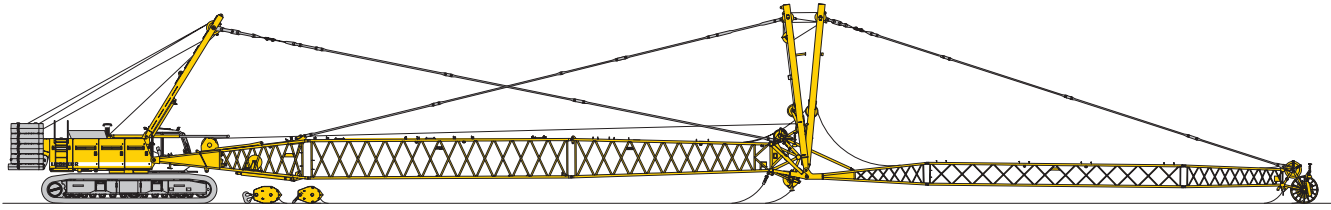

Reeving of hoist and jib ropes



Erecting of main boom and luffing jib

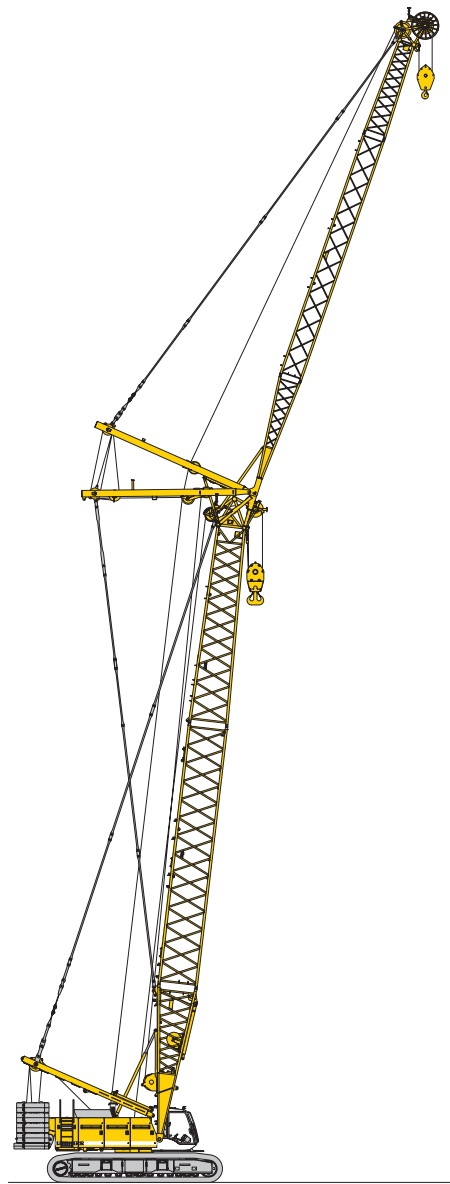

Working position

Working range - main boom (No. 2017.xx) **86° - 15°** max. 112,215 lbs counterweight and 44,100 lbs carbody counterweight

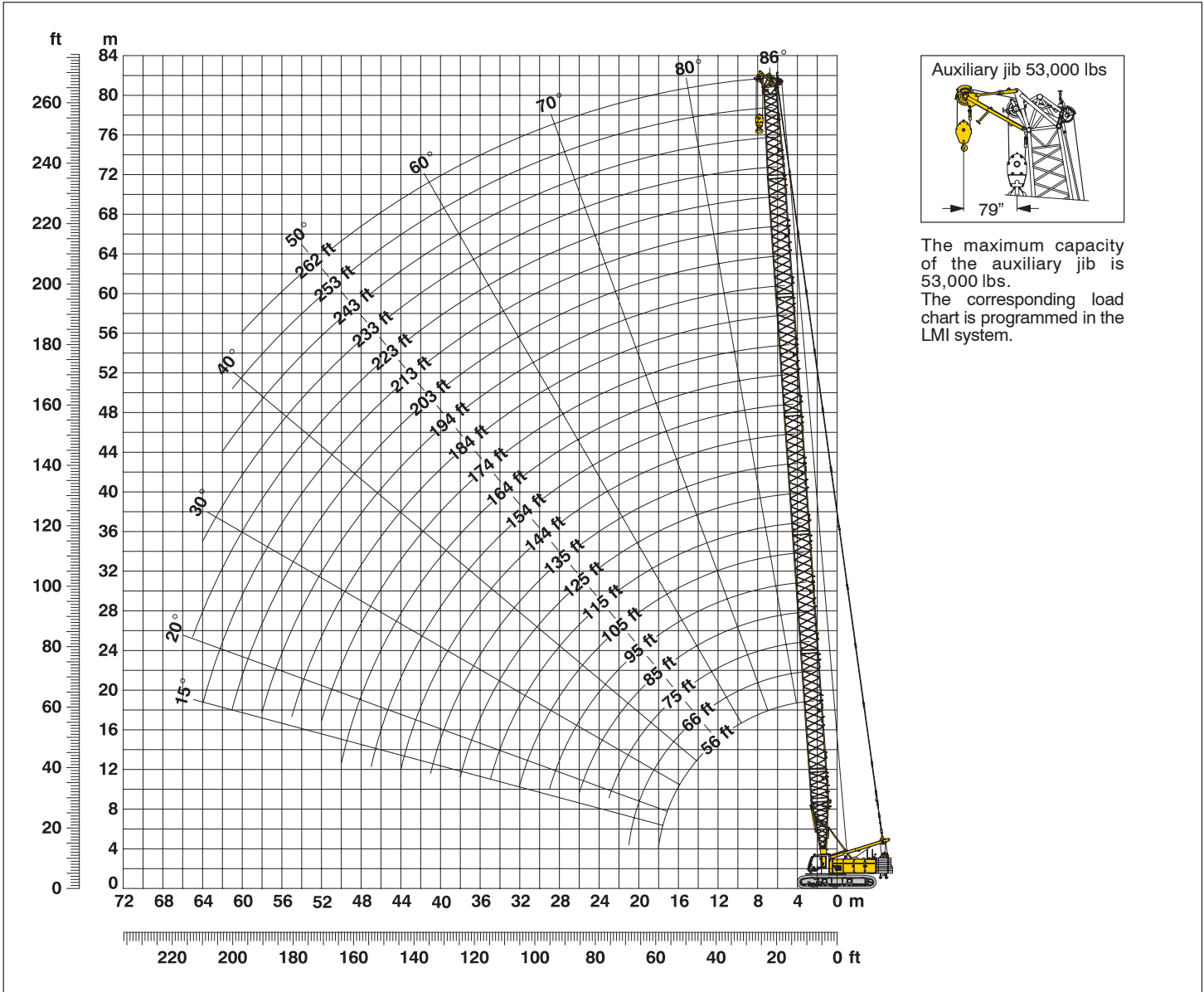

Main boom configuration (Table 1 - No. 2017.xx)

Configuration for boom lengths (56 ft – 262 ft)		Amount of boom extensions																					
Length		1	1	1	1	1	1	1	1	1	1	1	1	1	1	1	1	1	1	1	1	1	
Boom foot	23 ft	1	1	1	1	1	1	1	1	1	1	1	1	1	1	1	1	1	1	1	1	1	
Boom insert	10 ft*		1		1		1		1		1		1		1		1		1		1		
Boom insert	20 ft*			1	1		1		1		1		1		1		1		1		1		
Boom insert	40 ft*				1	1	1	1	1	2	2	2	2	3	3	3	3	4	4	4	4	5	5
Boom head	33 ft*	1	1	1	1	1	1	1	1	1	1	1	1	1	1	1	1	1	1	1	1	1	
Boom length (ft)		56	66	75	85	95	105	115	125	135	144	154	164	174	184	194	203	213	223	233	243	253	262

*Actual lengths of boom sections are metric (e.g. 3 m, 6 m, 10 m, 12 m). The figures shown above are approximate conversions to feet.

Lift chart for main boom (No. 2017.xx)

Capacities in 1000 lbs for boom lengths from (56 ft – 262 ft) – with 26,500 lbs winches counterweight 112,200 lbs and carbody counterweight 44,100 lbs

Radius (ft)	Boom length in (ft)												Radius (ft)	
	56 lbs	66 lbs	85 lbs	105 lbs	125 lbs	144 lbs	164 lbs	184 lbs	203 lbs	223 lbs	243 lbs	262 lbs		
12		302.5												12
15	281.5	289.5	247.4	207.1										15
20	210.7	220.7	207.6	188.7	162.4	140.4	119.8							20
25	169.9	174.2	168.3	164.9	147.0	128.2	113.6	98.2	83.6	68.5	57.2			25
30	147.6	141.1	142.1	140.6	135.7	117.5	107.3	95.1	80.8	66.9	56.6	46.3		30
35	120.8	123.5	120.1	118.4	116.6	109.8	99.4	91.7	77.6	65.4	55.2	45.2		35
40	102.4	100.4	102.0	99.9	99.2	95.2	94.8	89.2	75.3	63.2	53.8	44.3		40
45	87.1	87.2	87.1	87.0	86.7	86.3	85.6	83.9	73.6	61.3	50.7	42.6		45
50	75.5	75.7	75.6	75.4	74.2	74.8	73.2	71.1	69.3	60.0	49.5	41.1		50
55	66.4	66.6	66.6	66.4	66.0	65.7	65.2	64.8	64.1	56.9	48.5	40.0		55
65		53.2	53.3	53.2	51.6	52.3	50.9	50.8	50.9	49.6	45.1	37.2		65
70			48.2	48.1	47.7	47.3	46.8	46.4	45.9	45.4	43.8	35.8		70
80			40.2	40.2	39.8	39.4	38.9	38.4	37.9	37.4	36.9	33.5		80
85			36.9	37.0	36.6	36.2	35.7	35.2	34.7	34.2	33.6	32.6		85
90				34.2	33.8	33.4	32.9	32.5	31.9	31.4	30.8	30.3		90
100				29.4	29.1	28.8	28.3	27.8	27.2	26.7	26.3	24.7		100
110					25.5	25.2	24.7	24.2	23.7	23.1	22.6	22.0		110
120					22.4	22.1	21.6	21.1	20.6	20.0	19.5	18.9		120
130						19.5	19.0	18.5	18.0	17.4	16.9	16.3		130
140						17.3	16.8	16.3	15.8	15.3	14.7	14.1		140
150							14.9	14.4	13.9	13.4	12.8	12.2		150
160							13.2	12.8	12.2	11.7	11.1	10.6		160
170								11.3	10.8	10.3	9.7	9.1		170
180								10.0	9.5	9.0	8.4	7.8		180
190									8.3	7.9	7.3	6.7		190
200									7.3	6.8	6.2	5.7		200
210										5.9	5.3	4.8		210
215										5.4	4.9	4.3		215
220											4.5	3.9		220
230											3.7	3.1		230
235											3.3	2.8		235
240												2.4		240
245												2.1		245

Above lift chart is for reference only. For actual lift duty please refer to lift chart in operator's cab or manual.

L - boom high reach (No. 2017 / 1309.xx) 198 ft - 305 ft

Working range 86° - 15°

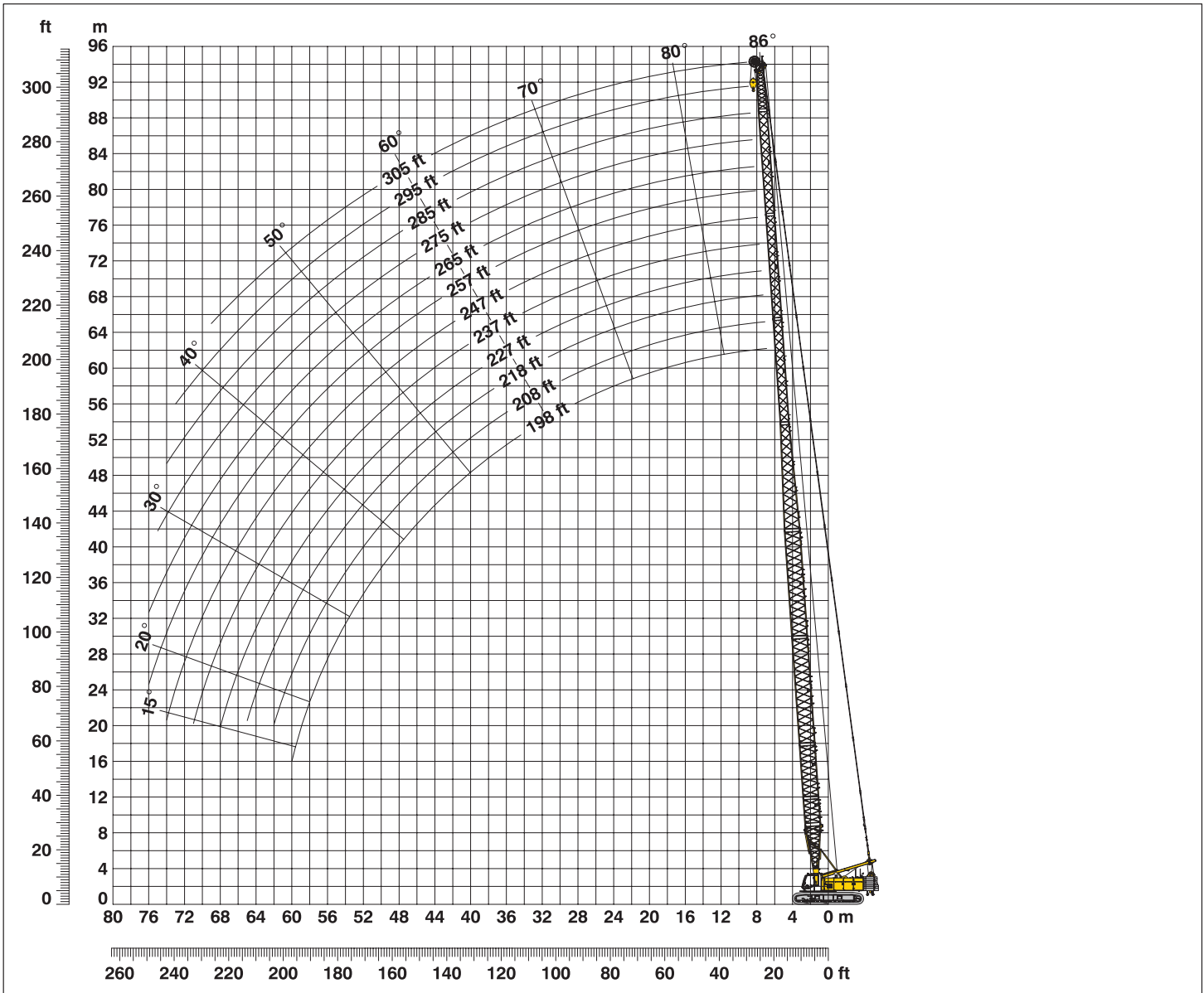

L - boom configuration with 131 ft main boom (No. 2017.xx / No. 1309.xx)

Configuration for L - boom lengths (198 ft - 304 ft)

	Length	Amount of boom and luffing jib extensions											
		1	1	1	1	1	1	1	1	1	1	1	1
Boom foot	23 ft	1	1	1	1	1	1	1	1	1	1	1	1
Boom insert	10 ft*	1	1	1	1	1	1	1	1	1	1	1	1
Boom insert	20 ft*	1	1	1	1	1	1	1	1	1	1	1	1
Boom insert	40 ft*	2	2	2	2	2	2	2	2	2	2	2	2
Tapered	40 ft*	1	1	1	1	1	1	1	1	1	1	1	1
Luffing insert	10 ft*	1		1		1		1		1		1	
Luffing insert	20 ft*		1	1			1		1		1		1
Luffing insert	38 ft*				1	1	1	1	2	2	2	2	3
Luffing jib head	18 ft	1	1	1	1	1	1	1	1	1	1	1	1
Max. L - boom length (ft)		198	208	218	227	237	247	257	265	275	285	295	304

*Actual lengths of boom sections are metric (e.g. 3 m, 6 m, 11.7 m, 12 m). The figures shown above are approximate conversions to feet.

Lift chart for L – boom (No. 2017 / 1309.xx)

Main boom length 131 ft

Capacities in 1000 lbs
counterweight 112,200 lbs and carbody counterweight 44,100 lbs

Radius (ft)	Boom length in (ft)				
	198	237	265	295	304
	lbs	lbs	lbs	lbs	lbs
19.7	94.9				
25	93.8	56.9	36.3		
30	90.9	54.9	35.4	23.0	20.9
40	80.2	49.7	32.4	20.9	18.8
50	63.8	46.1	29.7	18.9	17.0
60	50.0	42.8	27.1	17.3	15.4
70	45.4	39.4	24.4	15.9	14.2
80	40.6	36.3	22.5	14.6	13.0
90	34.7	32.7	20.5	13.6	12.1
100	30.0	29.7	18.4	12.3	11.1
110	25.7	24.9	17.0	11.1	9.9
120	23.3	23.0	15.8	10.2	9.0
130	20.8	20.4	14.9	9.6	8.4
140	18.6	18.2	14.2	9.1	7.9
150	16.7	16.4	13.4	8.7	7.5
160	15.1	14.7	12.7	8.3	7.2
170	13.6	13.3	12.2	7.9	6.8
180	12.4	12.1	11.2	7.6	6.5
190	11.2	10.9	10.3	7.3	6.3
195	10.7	10.4	9.9	7.2	6.2
210		9.0	8.7	6.7	5.8
220		8.2	7.7	6.4	5.6
230		7.3	6.8	6.1	5.5
240			6.0	5.2	5.0
250			5.1	4.4	4.2
255			4.7	4.1	3.8
270				3.1	2.9
280				2.4	2.3
285				2.1	

Main boom length 171 ft

Capacities in 1000 lbs
counterweight 112,200 lbs and carbody counterweight 44,100 lbs

Radius (ft)	Boom length in (ft)				
	238	258	276	296	305
	lbs	lbs	lbs	lbs	lbs
22.5	65.7				
25	65.7	51.8			
30	64.7	50.8	41.3	32.4	28.7
40	61.2	48.0	39.1	30.4	24.6
50	55.0	45.3	36.6	28.4	22.6
60	49.0	42.3	34.2	25.1	20.8
70	40.6	37.7	32.3	23.7	19.2
80	35.4	33.2	29.9	22.2	17.8
90	31.7	29.8	28.0	21.0	16.6
100	28.8	27.1	24.1	19.6	15.5
110	24.4	25.1	23.1	18.2	14.1
120	22.2	22.0	21.1	17.1	13.1
130	19.7	19.5	18.9	15.9	12.3
140	17.5	17.3	17.1	14.8	11.7
150	15.6	15.4	15.2	13.9	11.2
160	14.0	13.8	13.5	12.6	10.7
170	12.5	12.3	12.0	11.1	9.9
180	11.3	11.1	10.8	9.9	9.2
190	10.1	9.9	9.4	8.9	8.6
200	9.1	8.9	8.3	7.7	7.8
210	8.2	7.7	7.3	6.6	6.7
220	7.3	6.7	6.4	5.7	5.7
230	6.2	5.9	5.5	4.9	4.9
235		5.5	5.1	4.4	4.6
240		5.0	4.7	4.0	4.1
250		4.1	4.0	3.1	3.2
260			3.1	2.4	2.4
265			2.7	2.1	2.0
270			2.3		

Above lift chart is for reference only. For actual lift duty please refer to lift chart in operator's cab or manual.

L – boom configuration with 171 ft main boom (No. 2017.xx / No. 1309.xx)

Configuration for L – boom lengths (238 ft – 305 ft)

Configuration	Length	Amount of boom and luffing jib extensions							
		1	1	1	1	1	1	1	1
Boom foot	23 ft	1	1	1	1	1	1	1	1
Boom insert	10 ft*	1	1	1	1	1	1	1	1
Boom insert	20 ft*	1	1	1	1	1	1	1	1
Boom insert	40 ft*	3	3	3	3	3	3	3	3
Tapered	40 ft*	1	1	1	1	1	1	1	1
Luffing insert	10 ft*	1		1		1		1	
Luffing insert	20 ft*		1	1		1		1	
Luffing insert	38 ft*				1	1	1	1	2
Luffing jib head	18 ft	1	1	1	1	1	1	1	1
Max. L – boom length (ft)		238	248	258	266	276	286	296	305

*Actual lengths of boom sections are metric (e.g. 3 m, 6 m, 11.7 m, 12 m). The figures shown above are approximate conversions to feet.

Working range - luffing jib (No. 1309.xx) 78° - 15°

Main boom 88° - 45°

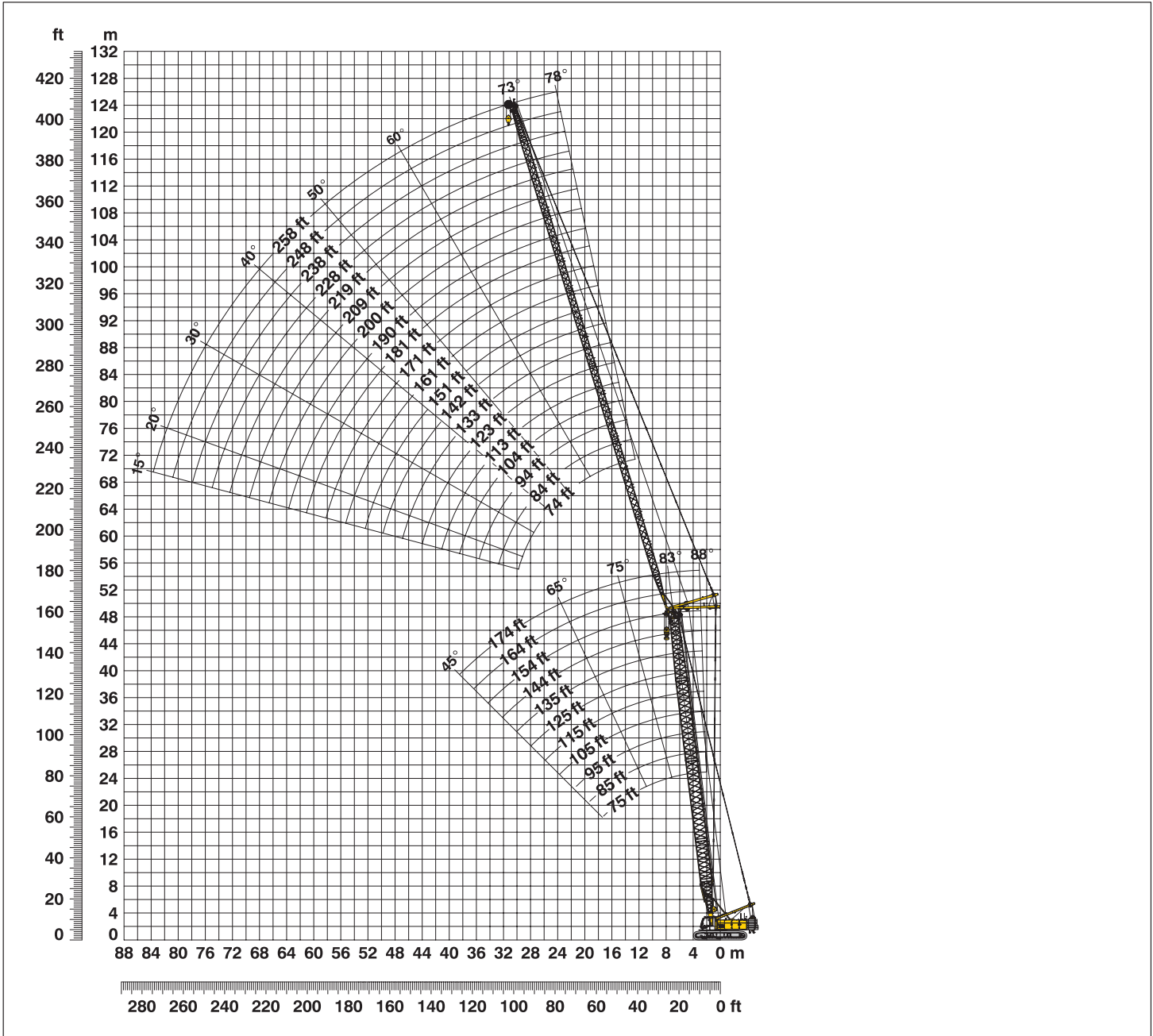

Boom configuration for main boom lengths (75 ft - 174 ft) – see table 1 on page 10

Jib configuration for jib lengths (74 ft - 258 ft) (No. 1309.xx)

	Length	Amount of luffing jib extensions																			
Luffing jib foot	18 ft	1	1	1	1	1	1	1	1	1	1	1	1	1	1	1	1	1	1	1	
Luffing jib insert	10 ft*		1		1		1		1		1		1		1		1		1		
Luffing jib insert	20 ft*			1	1		1	1		1	1		1	1		1	1		1	1	
Luffing jib insert	38 ft*	1	1	1	1	2	2	2	2	3	3	3	3	4	4	4	4	5	5	5	5
Luffing jib head	18 ft	1	1	1	1	1	1	1	1	1	1	1	1	1	1	1	1	1	1	1	1
Luffing jib length (ft)		74	84	94	104	113	123	133	142	151	161	171	181	190	200	209	219	228	238	248	258

*Actual lengths of boom sections are metric (e.g. 3 m, 6 m, 11.7 m). The figures shown above are approximate conversions to feet.

Lift chart – tower crane (No. 1309.xx)

Main boom angle 88°

Main boom 75 ft

Radius (ft)	Jib length in (ft)							
	74	94	113	133	161	199	228	258
27	104.9							
35	94.9	85.2	69.7					
40	86.2	80.2	68.1	54.4				
50	71.9	68.2	62.9	51.4	35.9			
55	66.1	63.7	59.4	50.3	34.8	20.3		
60	61.6	59.3	56.0	48.9	33.8	19.9	15.0	
70	53.1	51.1	49.2	44.9	32.1	19.3	14.3	9.7
75	46.7	47.8	46.1	43.2	31.2	19.0	14.0	9.4
80	44.8	44.7	43.6	40.6	30.5	18.8	13.6	9.1
100		26.6	33.8	32.7	27.1	17.7	12.5	8.0
115			28.1	27.6	24.8	16.9	11.8	7.3
135				23.3	21.7	15.9	11.0	6.6
160					17.8	14.8	10.3	5.9
200						11.5	9.5	5.2
225							8.2	4.9
255								4.7

Main boom 105 ft

Radius (ft)	Jib length in (ft)							
	74	94	113	133	161	199	228	258
28	92.1							
35	84.5	73.7						
40	77.7	69.9	60.7					
45	72.2	66.2	58.7	47.2				
50	67.6	62.3	55.9	46.4	33.6			
55	63.0	59.1	53.6	45.3	32.8	21.2		
65	55.8	50.4	48.5	42.7	31.3	19.4	13.9	
70	51.1	49.2	46.3	41.2	30.7	19.1	13.6	9.3
80	45.5	44.6	42.2	38.4	29.2	18.3	13.1	8.7
100		34.5	34.3	33.0	26.7	16.9	12.1	7.7
115			28.8	28.1	20.2	16.0	11.4	7.1
135				18.5	16.5	14.9	10.6	6.4
165					13.8	13.2	9.8	5.6
200						10.2	9.1	5.1
225							8.3	4.8
255								4.6

Main boom 125 ft

Radius (ft)	Jib length in (ft)							
	74	94	113	133	161	199	228	258
28.7	77.4							
35	72.4	63.9						
40	68.1	60.7	53.8					
45	63.3	57.5	51.1	42.3				
50	59.6	54.6	48.8	41.7	31.0			
55	55.6	50.9	46.9	40.5	30.5	19.9		
65	49.5	46.3	43.1	38.2	29.3	18.2	13.3	
70	47.1	44.1	41.3	36.9	28.8	18.0	13.0	8.9
80	42.5	40.2	37.8	34.6	27.4	17.2	12.5	8.4
100		33.2	31.9	30.1	21.5	15.9	11.6	7.5
120			17.1	15.6	17.6	14.7	10.8	6.7
135				14.5	14.8	13.9	10.3	6.3
165					11.9	12.1	9.5	5.5
200						9.4	8.9	5.0
230							7.1	4.6
255								4.4

Main boom 154 ft

Radius (ft)	Jib length in (ft)							
	74	94	113	133	161	199	228	258
29.8	61.1							
35	58.2	51.0						
40	54.7	48.7	43.0					
45	50.7	46.1	41.4	35.0				
50	48.7	44.0	39.6	34.4	25.1			
60	43.6	40.2	36.3	32.5	24.1	16.4		
65	41.4	38.1	34.9	31.3	23.6	16.1	12.0	
70	39.3	36.4	33.5	30.1	23.1	15.9	11.9	8.1
85	20.4	32.6	29.8	27.0	21.0	14.9	11.3	7.6
100		28.1	16.1	17.5	18.1	14.0	10.7	7.0
120			13.3	13.2	14.1	12.8	10.0	6.4
140				11.3	11.2	11.7	9.4	5.9
165					9.2	9.9	8.9	5.3
205						7.3	8.1	4.7
230							5.7	4.4
260								4.3

Main boom 164 ft

Radius (ft)	Jib length in (ft)							
	74	94	113	133	161	181	199	228
30.1	56.8							
35	54.1	47.4						
40	50.6	45.3	39.8					
45	47.7	43.0	38.6	32.7				
50	45.4	41.0	36.9	32.1	23.1			
55	42.8	38.9	35.5	31.1	22.8	18.8		
60	40.8	37.3	33.8	30.2	22.3	18.3	15.6	
65	39.1	35.4	32.5	29.2	21.7	18.0	15.2	11.5
85	18.6	29.5	27.8	21.3	19.3	16.4	14.2	10.8
100		15.2	14.9	14.6	16.3	15.1	13.2	10.3
120			11.8	11.8	12.1	12.4	12.1	9.6
140				10.3	10.1	10.6	11.0	9.1
165					8.6	9.2	9.6	8.5
185						8.2	8.6	8.1
205							7.0	7.6
230								5.2

Main boom 174 ft

Radius (ft)	Jib length in (ft)							
	74	84	94	104	113	123	133	161
30.4	51.7							
35	49.6	46.7	43.7					
40	46.8	44.2	42.0	39.5	36.9			
45	44.2	42.1	39.9	37.8	35.8	33.0	30.6	
50	42.1	39.7	38.1	36.1	34.3	32.1	29.9	21.5
60	37.9	36.1	34.8	33.0	31.5	29.8	28.2	20.6
70	34.7	33.1	31.6	30.3	29.2	27.5	24.6	19.5
80	31.7	30.6	29.3	28.0	26.8	21.9	23.0	18.5
85	31.0	29.5	28.3	27.0	16.7	19.2	20.6	18.0
95		15.2	15.2	15.1	14.6	15.2	16.7	16.9
100			14.2	14.3	13.9	14.4	15.3	15.7
110				12.9	12.8	12.8	13.5	13.7
120					11.8	11.7	11.9	12.2
130						10.7	10.8	10.7
140							9.9	9.5
165								7.9

Capacities in 1000 lbs with luffing jib (No. 1309.xx) 112,200 lbs counterweight + 44,100 lbs carbody counterweight. Above lift chart is for reference only. For actual lift duty and complete chart with all available configurations please refer to lift chart in operator's cab or manual.

Lift chart - luffing jib (No. 1309.xx)

Main boom angle 83°

Main boom 75 ft

Radius (ft)	Jib length in (ft)							
	74	94	113	133	161	199	228	258
40	97.4							
50	79.3	77.1						
55	70.3	70.0	64.9					
60	63.1	62.8	62.3	50.9				
70	52.2	51.9	51.5	48.3	33.4			
80	44.3	44.0	43.7	43.4	31.7	19.9		
85	41.1	40.9	40.6	40.2	30.9	19.5	14.1	
95		35.7	35.4	35.0	29.7	18.7	13.2	8.5
100		33.5	33.2	32.9	28.6	18.3	12.9	8.3
105		26.6	31.3	30.9	27.6	17.9	12.7	8.0
120			26.5	26.2	25.7	17.1	11.9	7.4
140				21.5	21.0	16.0	11.1	6.7
170					16.1	14.7	10.2	5.8
205						11.6	9.5	5.2
235							8.0	4.9
265								4.7

Main boom 105 ft

Radius (ft)	Jib length in (ft)							
	74	94	113	133	161	199	228	258
43.6	80.5							
50	74.5	67.9						
55	69.0	64.8	57.6					
65	56.4	56.1	53.8	45.7				
70	51.5	51.2	50.1	44.5	31.8			
85	40.6	40.3	40.0	39.6	30.0	18.8		
90	37.9	37.6	37.3	36.9	29.3	18.5	12.9	
100		33.0	32.8	32.4	28.2	17.8	12.5	8.0
110		26.4	29.1	28.7	26.7	17.2	12.0	7.7
125			23.5	21.8	22.0	16.4	11.3	7.1
145				18.9	18.0	15.4	10.6	6.4
175					14.3	13.7	9.8	5.6
210						10.7	9.1	5.0
235							8.3	4.7
250								4.7
265								4.6

Main boom 125 ft

Radius (ft)	Jib length in (ft)							
	74	94	113	133	161	199	228	258
46	67.7							
55	60.6	56.7						
60	57.1	53.6	48.6					
65	51.2	49.7	46.5	41.0				
75	46.9	44.6	42.3	38.5	29.6			
85	40.2	39.9	38.4	35.8	28.3	17.7		
95	26.6	34.8	34.5	33.0	26.9	17.2	12.4	
100		32.7	32.4	31.7	24.8	16.9	12.1	8.0
110		29.0	28.8	28.4	22.5	16.3	11.7	7.5
130			23.3	17.0	18.5	15.2	10.9	6.8
150				15.2	15.0	14.3	10.2	6.2
175					12.4	12.5	9.6	5.5
190						11.6	9.3	5.2
215						9.4	8.8	4.9
240							7.9	4.6
270								4.4

Main boom 154 ft

Radius (ft)	Jib length in (ft)							
	74	94	113	133	161	199	228	258
49.6	52.2							
60	46.6	42.8						
65	44.1	40.8	37.4					
70	41.4	38.7	35.8	32.1				
75	39.5	36.9	34.0	30.8	24.9			
90	34.7	32.0	29.7	27.4	22.5	15.5		
95	33.1	30.8	28.5	24.5	21.7	15.2	11.7	
105		28.8	20.9	20.8	20.4	14.8	11.0	7.2
115		16.8	17.9	18.2	18.2	14.2	10.7	7.0
130			15.2	15.0	15.6	13.4	10.2	6.5
150				12.6	12.6	12.1	9.6	5.9
180					10.0	10.2	8.9	5.2
215						8.1	7.9	4.7
245							5.9	4.4
260								4.4
275								4.3

Main boom 164 ft

Radius (ft)	Jib length in (ft)							
	74	94	113	133	161	181	199	228
50.8	47.7							
60	43.1	39.7						
65	40.8	37.7	34.5					
70	38.2	35.5	32.8	29.3				
80	34.8	32.0	29.7	27.3	22.0			
85	33.5	30.5	28.5	24.9	21.4	18.0		
90	32.3	29.3	27.1	23.9	20.7	17.7	14.7	
95	30.9	28.2	22.2	22.8	20.0	17.3	14.6	
115		16.5	16.6	16.5	16.6	15.5	13.4	10.4
135			12.7	13.7	13.1	12.6	12.1	9.7
150				11.9	11.2	11.1	11.1	9.1
180					8.9	9.0	9.1	8.1
200						8.0	8.0	7.4
215							7.2	7.1
230								6.3
245								5.4

Main boom 174 ft

Radius (ft)	Jib length in (ft)							
	74	84	94	104	113	123	133	161
52	43.3							
55	42.4	39.6						
60	39.7	37.9	36.5					
65	37.5	35.7	34.4	33.0	31.4			
70	35.2	33.9	32.5	31.3	30.1	28.5	26.7	
80	31.9	30.3	29.3	28.4	27.2	24.8	23.8	19.8
90	29.7	28.1	26.9	23.3	23.1	22.9	21.8	18.7
100	19.2	19.0	19.9	20.3	19.8	20.0	19.9	17.3
105		17.9	18.0	18.6	18.4	18.8	18.9	16.7
115			15.8	15.9	16.1	16.5	17.1	15.4
125				14.1	14.3	14.6	15.0	14.1
135					12.6	13.1	13.3	13.0
145						11.7	12.1	11.9
155							10.9	11.0
160								10.6
180								9.0

Capacities in 1000 lbs with luffing jib (No. 1309.xx) 112,200 lbs counterweight + 44,100 lbs carbody counterweight. Above lift chart is for reference only. For actual lift duty and complete chart with all available configurations please refer to lift chart in operator's cab or manual.

Lift chart – luffing jib (No. 1309.xx)

Main boom angle 75°

Main boom 75 ft

Radius (ft)	Jib length in (ft)							
	74	94	113	133	161	199	228	258
60	53.0							
70	49.8	49.4						
80	42.3	41.9	41.5					
85	39.3	38.9	38.5	38.1				
95	34.2	34.0	33.6	33.2				
100		31.9	31.5	31.1	30.1			
115		26.8	26.6	26.2	25.5	17.7		
125			23.9	23.5	22.9	17.2	12.2	
130			22.7	22.4	21.8	16.9	11.8	
140				20.3	19.7	16.4	11.4	6.9
150				18.5	18.0	15.9	11.0	6.6
180					13.9	13.2	10.1	5.8
215						9.9	9.4	5.2
245							7.3	4.8
260								4.7
275								4.6

Main boom 105 ft

Radius (ft)	Jib length in (ft)							
	74	94	113	133	161	199	228	258
67.7	50.0							
80	40.8	40.3						
85	37.9	37.4	37.0					
95	33.0	32.6	32.2	31.8				
100	31.0	30.6	30.3	29.8				
105		28.8	28.5	28.0	27.3			
120		24.5	24.1	23.7	23.0			
125			22.9	22.5	21.8	16.9		
135			20.7	20.3	19.7	16.4	11.3	
140			19.8	19.4	18.8	16.2	11.1	
145				18.5	17.9	16.0	10.9	6.7
160				16.2	15.6	14.8	10.4	6.3
190					12.1	11.4	9.7	5.5
225						8.6	8.0	5.0
255							6.2	4.7
280								4.4

Main boom 125 ft

Radius (ft)	Jib length in (ft)							
	74	94	113	133	161	199	228	258
72.8	44.4							
85	36.7	36.3						
90	34.3	33.8	33.4					
100	30.1	29.7	29.3	28.8				
110	26.7	26.4	26.0	25.5	24.8			
130		21.4	21.1	20.6	19.9	16.0		
140			19.1	18.7	18.0	15.5	10.8	
145			18.2	17.8	17.2	15.3	10.7	
155				16.3	15.7	14.8	10.3	6.3
165				14.9	14.3	13.5	10.1	6.1
195					11.2	10.4	9.3	5.4
230						7.8	7.2	4.8
240							6.6	4.7
255							5.8	4.6
270								4.3
285								3.8

Main boom 154 ft

Radius (ft)	Jib length in (ft)							
	74	94	113	133	161	199	228	258
80.4	37.4							
90	32.5	32.0						
100	28.6	28.1	27.6					
105	26.9	26.5	26.0	23.9				
115	24.0	23.6	23.2	22.4				
120		22.4	22.0	21.5	18.5			
135		19.2	18.9	18.4	17.2	12.9		
150			16.4	16.0	15.3	12.4	9.4	
155			15.7	15.3	14.6	12.2	9.3	
160				14.6	14.0	11.9	9.2	5.9
170				13.4	12.8	11.2	8.9	5.8
200					9.9	9.1	8.0	5.1
235						6.8	6.1	4.5
265							4.7	3.6
280								3.1
295								2.7

Main boom 164 ft

Radius (ft)	Jib length in (ft)							
	74	94	113	133	161	181	199	228
83	32.6							
95	29.0	27.4						
100	27.7	25.6	24.1					
110	24.6	23.4	22.3	20.6				
120	22.3	21.3	20.3	19.2	16.4			
130		19.7	18.7	17.5	15.7	13.7		
140		17.9	17.1	16.2	14.5	13.2	11.4	
150			16.0	14.9	13.2	12.4	10.9	8.4
155			15.3	14.4	12.7	11.8	10.7	8.4
175				12.5	11.0	10.3	9.3	7.7
205					9.2	8.5	7.6	6.4
220						7.8	6.9	5.7
230							6.6	5.3
240							6.2	5.0
250								4.7
265								4.3

Main boom 174 ft

Radius (ft)	Jib length in (ft)							
	74	84	94	104	113	123	133	161
85.5	28.3							
90	27.3	25.9						
95	25.5	24.7	24.0					
100	24.4	23.6	23.0	22.0				
105	23.3	22.5	22.0	21.3	20.6			
110	22.2	21.6	21.0	20.4	19.7	18.9		
115	21.2	20.5	20.2	19.4	18.9	18.1	17.5	
120	20.7	19.5	19.2	18.6	18.0	17.4	16.7	
125		18.9	18.2	17.8	17.2	16.5	16.1	13.9
130		18.4	17.5	16.9	16.5	15.9	15.4	13.6
140			16.5	15.6	15.1	14.6	14.3	12.6
150				14.8	14.2	13.4	13.1	11.6
160					13.4	12.7	12.1	10.8
170						12.0	11.5	10.0
180							10.9	9.2
205								8.1

Capacities in 1000 lbs with luffing jib (No. 1309.xx) 112,200 lbs counterweight + 44,100 lbs carbody counterweight. Above lift chart is for reference only. For actual lift duty and complete chart with all available configurations please refer to lift chart in operator's cab or manual.

Lift chart - luffing jib (No. 1309.xx)

Main boom angle 65°

Main boom 75 ft

Radius (ft)	Jib length in (ft)							
	74	94	113	133	161	199	228	258
83.4	37.9							
95	32.3	31.9						
110	26.9	26.6	26.2					
120		23.9	23.5	23.0				
130		21.5	21.2	20.8				
135			20.2	19.8	19.1			
145			18.4	18.0	17.3			
160				15.7	15.1	14.2		
165				15.1	14.5	13.6		
175					13.3	12.4	10.3	
190					11.8	10.9	9.9	5.6
230						7.9	7.3	5.0
240							6.7	4.9
255							5.9	4.7
270								4.5
285								3.9

Main boom 105 ft

Radius (ft)	Jib length in (ft)							
	74	94	113	133	161	199	228	258
95.9	29.7							
110	25.1	24.7						
120	22.5	22.1	21.7					
130		19.9	19.5	19.0				
140		18.1	17.7	17.2				
150			16.2	15.7	15.0			
160			14.8	14.4	13.7			
170				13.2	12.5	11.6		
180				12.1	11.5	10.6		
185					11.0	10.1	9.4	
205					9.3	8.5	7.8	5.3
220						7.5	6.8	5.1
245						6.0	5.4	4.6
270							4.3	3.6
290								2.8
300								2.5

Main boom 125 ft

Radius (ft)	Jib length in (ft)							
	74	94	113	133	161	199	228	258
104.2	25.3							
120	21.2	20.7						
130	19.1	18.7	18.3					
140		17.0	16.6	16.0				
150		15.4	15.1	14.6				
155			14.4	13.9	13.1			
170			12.6	12.2	11.5			
180				11.2	10.5	9.6		
185				10.7	10.1	9.1		
195					9.3	8.3	7.4	
210					8.2	7.3	6.5	5.2
215					7.8	7.0	6.2	4.9
250						5.1	4.4	3.3
280							3.2	2.2
285								2.1

Main boom 154 ft

Radius (ft)	Jib length in (ft)							
	74	94	113	133	161	199	228	248
116.7	19.7							
130	15.2	16.7						
140	13.1	15.1	14.6					
150		13.8	13.3	12.7				
160		12.6	12.1	11.6				
170			11.1	10.6	9.8			
180			10.2	9.7	9.0			
190				8.9	8.2	6.7		
200				8.2	7.5	6.1		
205					7.2	5.8	4.6	
220					6.3	5.1	3.9	3.1
225					6.0	4.8	3.7	2.9
245						4.0	2.9	2.1
265						3.3	2.3	
270							2.1	

Main boom 164 ft

Radius (ft)	Jib length in (ft)							
	74	94	113	133	161	181	199	228
120.9	18.1							
135	13.5	15.1						
145	11.7	13.7	13.3					
155		12.5	12.1	11.5				
165		11.4	11.0	10.5				
175			10.1	9.6	8.7			
185			9.2	8.8	7.9	7.0		
195				8.0	7.3	6.4	5.6	
200				7.7	7.0	6.1	5.4	
210					6.4	5.6	4.8	3.6
230					5.3	4.7	4.0	2.8
240						4.3	3.6	2.5
250						3.9	3.2	2.1
260							2.9	
265							2.8	

Main boom 174 ft

Radius (ft)	Jib length in (ft)							
	74	84	94	104	113	123	133	161
125	16.6							
130	15.8							
135	15.0	14.7						
140	14.3	14.0	13.7					
145	13.6	13.3	13.1	12.8				
150	13.0	12.7	12.5	12.2	12.0			
155		12.1	11.9	11.6	11.5	11.1		
160		11.6	11.4	11.1	10.9	10.6	10.4	
170			10.4	10.1	10.0	9.7	9.4	
175				9.7	9.6	9.3	9.0	7.8
180				9.3	9.1	8.9	8.6	7.5
190					8.4	8.1	7.9	6.9
200						7.4	7.2	6.3
205							6.9	6.0
235								4.6

Capacities in 1000 lbs with luffing jib (No. 1309.xx) 112,200 lbs counterweight + 44,100 lbs carbody counterweight. Above lift chart is for reference only. For actual lift duty and complete chart with all available configurations please refer to lift chart in operator's cab or manual.

Lift chart – luffing jib (No. 1309.xx)

Main boom angle 45°

Main boom 75 ft

Radius (ft)	Jib length in (ft)							
	74	94	113	133	161	199	228	258
122.4	20.9							
130	19.4							
140		17.1						
150		15.7						
155			14.6					
170			12.8	12.3				
190				10.5				
200					9.0			
215					8.0			
225						6.4		
250						5.2	4.5	
275							3.5	2.8
280							3.3	2.6
295								2.1

Main boom 105 ft

Radius (ft)	Jib length in (ft)							
	74	94	113	133	161	199	228	258
143.3	14.6							
150	13.8							
160		12.1						
170		11.1						
175			10.2					
190			9.0					
195				8.2				
205				7.5				
215					6.1			
230					5.4			
235					5.1			
250						3.6		
270						2.8	2.0	
275						2.6		

Main boom 125 ft

Radius (ft)	Jib length in (ft)				
	74	94	113	133	161
157.2	11.2				
165	10.5				
175		9.1			
185		8.3			
190			7.5		
200			6.9		
205				6.1	
210				5.8	
220				5.3	
230					4.1
240					3.7
250					3.3

Main boom 154 ft

Radius (ft)	Jib length in (ft)			
	74	94	113	133
178.1	7.0			
180	6.9			
190	6.2			
195		5.4		
200		5.2		
205		4.9		
210			4.2	
220			3.8	
225			3.6	
230				2.9
240				2.5
245				2.4

Main boom 164 ft

Radius (ft)	Jib length in (ft)		
	74	94	113
185.1	5.7		
190	5.4		
195	5.1		
205		4.2	
210		3.9	
220			3.1
225			2.9
230			2.7

Main boom 174 ft

Radius (ft)	Jib length in (ft)			
	74	84	94	104
192	4.5			
195	4.4			
200	4.2			
205		3.6		
210		3.4	3.2	
215			3.0	
220			2.8	2.4
225				2.3

Capacities in 1000 lbs with luffing jib (No. 1309.xx) 112,200 lbs counterweight + 44,100 lbs carbody counterweight. Above lift chart is for reference only. For actual lift duty and complete chart with all available configurations please refer to lift chart in operator's cab or manual.

Working range - fixed jib (No. 0806.xx) 15° and 30°

Main boom 88°- 30°

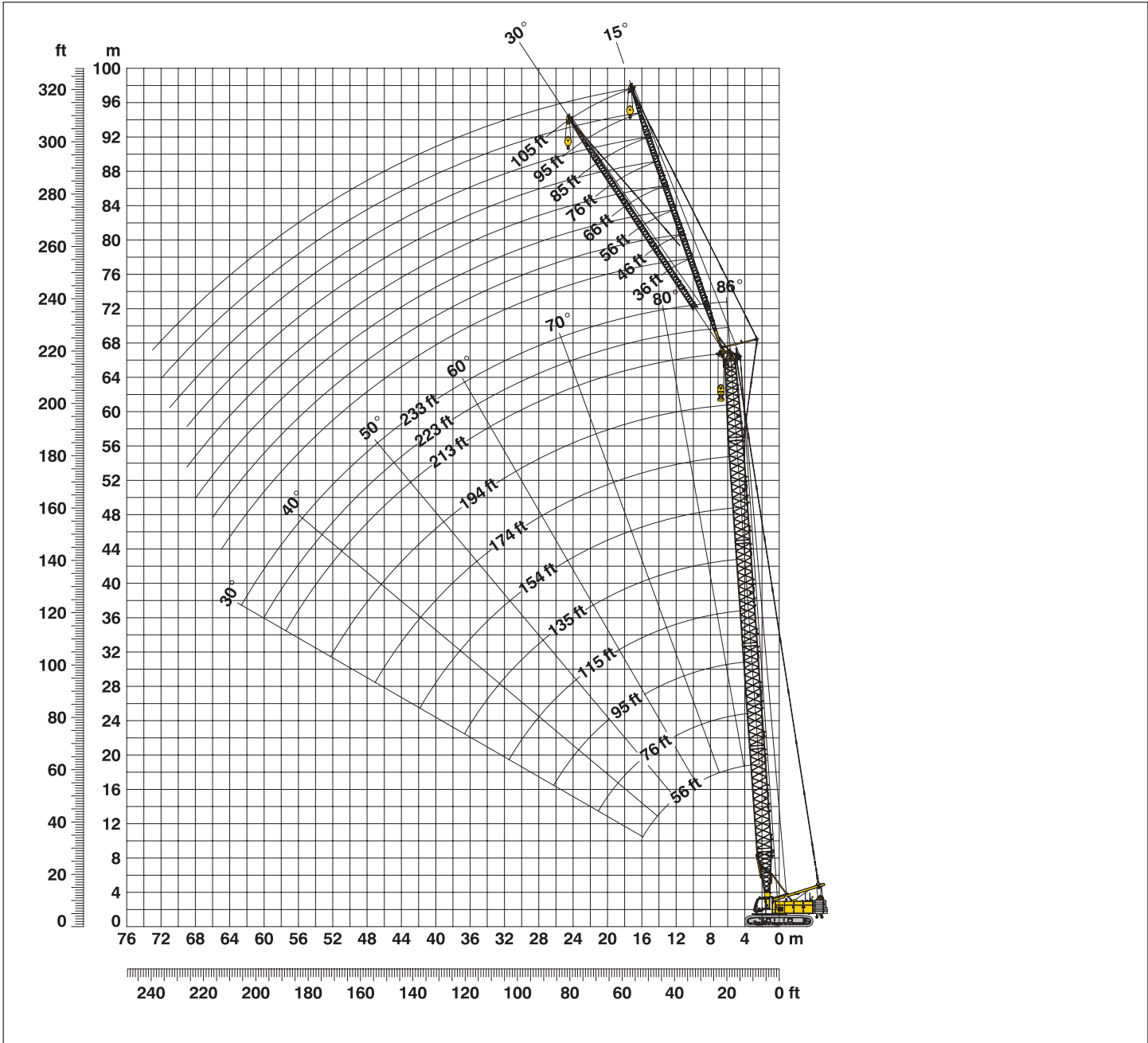

Boom configuration for boom lengths (56 ft - 233 ft) – see table 1 on page 10

Fixed jib configuration for fixed jib lengths (36 ft - 105 ft) (No. 0806.xx)

	Length	Amount of fixed jib extensions								
		1	1	1	1	1	2	2	3	3
Fixed jib foot	18 ft	1	1	1	1	1	1	1	1	1
Fixed jib insert	10 ft*		1			1		1		1
Fixed jib insert	20 ft*			1		1	2	2	3	3
Fixed jib head	18 ft	1	1	1	1	1	1	1	1	1
Fixed jib length (ft)		36	46	56	66	76	85	95	105	

*Actual lengths of boom sections are metric (e.g. 3 m, 6 m). The figures shown above are approximate conversions to feet.

Lift chart - fixed jib (No. 0806.xx)

Offset 15°

Main boom 56 ft

Radius	Fixed jib length in (ft)			
	36	66	85	105
(ft)	lbs	lbs	lbs	lbs
18	53.0			
35	53.0	36.7		
40	53.0	35.6	20.9	
50	52.8	33.3	19.7	12.1
55	52.7	31.6	18.8	11.7
60	51.9	30.2	18.1	11.4
70	44.8	27.4	16.8	10.8
80	40.0	24.4	15.8	10.3
85	37.9	23.7	15.4	10.0
115		19.2	13.7	9.1
135			13.1	8.7
155				8.4

Main boom 85 ft

Radius	Fixed jib length in (ft)			
	36	66	85	105
(ft)	lbs	lbs	lbs	lbs
19	53.0			
35	53.0	37.1		
40	53.0	36.2	22.8	
50	53.0	34.3	20.1	12.0
60	52.6	32.4	19.0	11.4
70	49.7	30.2	18.0	10.9
80	41.7	28.1	16.9	10.5
100	30.9	24.2	15.4	9.8
110	27.0	22.6	14.8	9.4
140		19.4	13.7	8.8
160			13.1	8.5
180				8.2

Main boom 115 ft

Radius	Fixed jib length in (ft)			
	36	66	85	105
(ft)	lbs	lbs	lbs	lbs
20	53.0			
35	53.0	35.5		
45	53.0	34.2	20.0	
50	53.0	33.5	19.6	12.0
60	53.0	32.0	18.8	11.5
80	41.0	29.0	17.0	10.6
100	30.1	24.6	15.6	9.9
120	23.2	22.6	14.5	9.4
140	18.3	19.4	13.8	9.0
170		14.2	13.0	8.5
190			12.1	8.3
205				8.2

Main boom 144 ft

Radius	Fixed jib length in (ft)			
	36	66	85	105
(ft)	lbs	lbs	lbs	lbs
21.1	53.0			
35	53.0	35.1		
45	53.0	34.1	20.2	
50	53.0	33.6	19.9	12.5
60	52.4	32.4	19.1	11.5
80	40.2	30.2	17.7	10.6
100	29.3	27.9	16.2	10.0
140	17.5	18.7	14.3	9.1
165	13.1	14.2	13.6	8.7
195		10.3	10.9	8.3
215			8.8	8.2
235				7.6

Main boom 174 ft

Radius	Fixed jib length in (ft)			
	36	66	85	105
(ft)	lbs	lbs	lbs	lbs
22.1	53.0			
35	53.0	32.5		
45	53.0	32.0	19.2	
55	53.0	31.1	18.7	11.5
60	53.0	30.7	18.3	11.3
80	39.4	29.1	17.2	10.6
120	21.6	22.0	15.3	9.6
160	13.1	14.2	13.3	8.8
190	9.1	10.1	10.6	8.2
215		7.5	8.1	7.8
235			6.4	6.8
255				5.4

Main boom 194 ft

Radius	Fixed jib length in (ft)			
	36	66	85	105
(ft)	lbs	lbs	lbs	lbs
22.8	53.0			
40	53.0	30.9		
45	53.0	30.7	18.7	
55	51.4	29.9	18.3	11.4
60	50.8	29.6	17.9	11.2
100	28.0	22.5	15.9	10.1
140	16.1	17.3	13.6	9.2
180	9.7	10.7	11.3	8.6
205	7.0	7.9	8.5	8.0
235		5.3	5.9	6.3
255			4.4	4.9
275				3.6

Main boom 213 ft

Radius	Fixed jib length in (ft)			
	36	66	85	105
(ft)	lbs	lbs	lbs	lbs
23.5	51.4			
40	49.7	29.3		
45	49.1	29.1	18.1	
55	47.1	28.4	17.8	11.2
80	38.4	26.7	16.7	10.5
120	20.4	21.9	15.1	9.6
160	11.9	13.1	13.1	8.9
200	6.9	7.9	8.5	8.2
225	4.6	5.6	6.1	6.6
255		3.4	3.9	4.4
275			2.6	3.1
290				2.3

Main boom 223 ft

Radius	Fixed jib length in (ft)			
	36	66	75	85
(ft)	lbs	lbs	lbs	lbs
23.8	48.6			
40	46.8	28.3		
45	46.0	28.1	22.1	17.8
60	42.7	27.2	21.3	17.3
80	37.4	24.4	20.2	16.5
100	27.1	23.1	19.2	15.7
160	11.6	12.8	13.1	13.3
200	6.6	7.6	7.9	8.2
230	3.9	4.9	5.2	5.4
260		2.8	3.0	3.3
270			2.4	2.7
280				2.1

Main boom 233 ft

Radius	Fixed jib length in (ft)			
	36	46	56	
(ft)	lbs	lbs	lbs	
24.2	45.1			
30	45.0	38.4		
35	44.9	38.3	33.0	
40	43.9	38.1	32.8	
60	39.8	35.4	31.4	
80	35.4	32.5	29.2	
120	19.8	20.4	20.9	
160	11.3	11.7	12.1	
200	6.3	6.6	7.0	
240	2.9	3.2	3.6	
250		2.5	2.9	
260			2.2	

Capacities in 1000 lbs with fixed jib (No. 0806.xx) 112,200 lbs counterweight + 44,100 lbs carbody counterweight. Above lift chart is for reference only. For actual lift duty and complete chart with all available configurations please refer to lift chart in operator's cab or manual.

Lift chart - fixed jib (No. 0806.xx)

Offset 30°

Main boom 56 ft

Radius	Fixed jib length in (ft)			
	36	66	85	105
(ft)	lbs	lbs	lbs	lbs
26.2	53.0			
45	50.7	30.5		
60	42.8	25.0	15.9	
70	38.8	23.1	15.2	10.0
80	35.9	21.5	14.5	9.6
90	34.1	20.1	14.0	9.3
100		19.0	13.5	9.0
120		17.8	12.9	8.7
130			12.6	8.5
140			12.4	8.4
150				8.3
160				8.1

Main boom 85 ft

Radius	Fixed jib length in (ft)			
	36	66	85	105
(ft)	lbs	lbs	lbs	lbs
27.3	53.0			
50	51.9	30.0		
60	47.6	27.4	16.5	
75	41.7	24.3	15.4	9.8
80	40.3	23.4	15.1	9.6
100	31.2	20.9	14.2	9.1
110	27.2	20.0	13.8	8.9
145		18.1	12.9	8.4
160			12.6	8.3
165			12.5	8.2
180				8.0
185				7.9

Main boom 115 ft

Radius	Fixed jib length in (ft)			
	36	66	85	105
(ft)	lbs	lbs	lbs	lbs
28.3	53.0			
50	53.0	29.2		
60	50.6	27.3	16.0	
75	45.4	24.2	15.3	9.7
80	41.6	23.7	15.0	9.6
100	30.6	21.6	14.1	9.2
120	23.5	19.8	13.6	8.8
140	18.4	18.6	13.0	8.6
170		14.3	12.5	8.3
190			12.3	8.1
200				8.1
205				8.0

Main boom 144 ft

Radius	Fixed jib length in (ft)			
	36	66	85	105
(ft)	lbs	lbs	lbs	lbs
29.3	53.0			
50	52.8	29.3		
65	51.0	27.3	15.9	
75	44.8	24.1	15.3	9.7
80	41.0	23.9	15.0	9.6
100	29.9	22.5	14.4	9.2
120	22.8	21.0	13.8	8.9
140	17.8	19.2	13.3	8.6
165	13.2	14.5	12.9	8.4
195		10.4	11.2	8.2
215			8.9	8.0
235				7.7

Main boom 174 ft

Radius	Fixed jib length in (ft)			
	36	66	85	105
(ft)	lbs	lbs	lbs	lbs
30.3	52.6			
50	51.6	27.6		
65	48.8	22.3	15.7	
75	44.2	21.6	15.1	9.6
80	40.4	21.4	14.8	9.5
100	29.2	20.9	14.0	9.2
120	22.1	20.4	13.5	8.9
160	13.4	14.7	12.5	8.3
190	9.2	10.4	11.1	7.7
220		7.2	7.9	7.6
240			6.1	6.8
260				5.2

Main boom 194 ft

Radius	Fixed jib length in (ft)			
	36	66	85	105
(ft)	lbs	lbs	lbs	lbs
31	49.5			
50	48.4	26.4		
65	44.6	21.2	14.5	
75	42.2	20.3	14.2	9.4
80	39.9	19.9	13.9	9.4
100	28.7	19.1	13.2	9.1
140	16.5	17.7	12.7	8.6
180	9.9	11.2	12.0	8.2
205	7.1	8.2	9.0	8.1
235		5.4	6.1	6.7
255			4.5	5.2
275				3.7

Main boom 213 ft

Radius	Fixed jib length in (ft)			
	36	66	85	105
(ft)	lbs	lbs	lbs	lbs
31.7	45.9			
55	43.8	22.1		
65	41.5	21.7	15.2	
75	39.6	21.3	15.0	9.8
80	38.6	21.0	14.8	9.3
120	21.1	18.3	13.5	8.8
160	12.3	13.7	12.4	8.4
200	7.1	8.3	9.0	7.9
225	4.8	5.9	6.5	7.2
255		3.5	4.1	4.7
275			2.7	3.4
295				2.1

Main boom 223 ft

Radius	Fixed jib length in (ft)			
	36	66	75	95
(ft)	lbs	lbs	lbs	lbs
32.1	43.4			
55	40.6	23.0		
60	39.7	22.9	18.4	
70	37.5	22.6	18.2	12.0
100	28.0	20.9	16.9	11.6
120	20.8	18.8	15.7	11.3
160	12.0	13.5	13.8	10.9
200	6.8	8.0	8.4	9.2
235	3.7	4.8	5.1	5.8
265		2.5	2.9	3.5
275			2.2	2.9
285				2.2

Main boom 233 ft

Radius	Fixed jib length in (ft)		
	36	46	56
(ft)	lbs	lbs	lbs
32.4	40.9		
40	40.5	34.2	
45	40.0	34.0	28.7
60	37.4	32.5	28.2
80	33.9	30.1	26.7
100	27.7	27.4	24.7
140	15.5	16.1	16.7
180	8.8	9.3	9.8
220	4.6	5.0	5.4
245	2.7	3.0	3.4
255		2.3	2.7
260			2.3

Capacities in 1000 lbs with fixed jib (No. 0806.xx) 112,200 lbs counterweight + 44,100 lbs carbody counterweight. Above lift chart is for reference only. For actual lift duty and complete chart with all available configurations please refer to lift chart in operator's cab or manual.

Notice

