

Manitex



TC700



















70-ton (63.5 mt) TELESCOPIC CRANE
TC700 SERIES PRODUCT GUIDE

















CONTENTS

Crane Features.....	4
Range Diagram	5
Load Chart: Main Boom.....	6
Load Chart: Main Boom.....	7
Load Chart: Main Boom.....	8
Jib Load Chart 31 ft. Retracted and 53 ft. Extended.....	9
Jib Load Chart 31 ft. Retracted and 53 ft. Extended.....	10
Jib Load Chart 31 ft. Retracted and 53 ft. Extended.....	11
Chassis Dimensions.....	12
Reeving Diagram, Area of Operation, Outrigger Extension	13
Technical Descriptions.....	14
Technical Descriptions.....	15



KEY

	Operator aids / Load limiter / Indicator
	Cab
	Heating/Air conditioning
	Controls
	Hoist line speed
	1 - Main hoist 2 - Auxiliary winch
	Rope length
	Rope - Standard/optional
	Rope diameter
	Permissible line pull
	Maximum line pull
	Slewing / Allowable slewing range
	Slewing gears
	Slewing brake
	Outriggers / Lifting on outriggers
	Removable counterweight system
	Counterweight
	Radio remote control

	Hook block
	Distance from hook to head sheave pin
	Hook and ball
	Hydraulics
	Max. boom length with extension
	Boom extension with offset
	Boom angle
	Telescoping mode
	Working radius
	Boom length
	Hydraulic actuated boom
	Mechanical synchronized
	Boom head / Hook block dimension
	Main boom with auxiliary head
	Tip height
	2-Person man basket

THE TC700 TELESCOPIC CRANE

Versatile. Affordable. User friendly.

The TC700 is built to meet the wide-ranging needs of owner operators who may use it for residential construction one day and bridge work the next. No matter what the task, the TC700 is designed to get you to the job and on the job quickly. With it, you can:

- Travel to and between job sites at highway speed on a commercial chassis
- Rig up quickly with radio outrigger controls
- Operate comfortably and confidently in its tiltable cab
- Removable counterweights and a travel length of 40 ft.

Other features include:

- 70-ton capacity, 8 ft. rated distance from center of rotation
- 115 ft. max. boom length
- 125 ft. max boom tip height
- 31 ft./53 ft. optional bi-fold jib
- Full Load Moment Indicator with work area definition
- Removable counterweight system

GET MORE DONE IN LESS TIME

When you're in business for yourself, time is money. The TC700 is designed specifically to rig up quickly by a single operator.

RADIO OUTRIGGER CONTROLS

Get out from behind the crane. Operate the outriggers remotely, with a clear view of the entire machine, using radio outrigger controls we call ROC Solid.

ON-BOARD OUTRIGGER PADS

Stop lugging outrigger pads. On the TC700 pads are stowed on the outriggers and move with them as the outriggers swing into position.

REMOTE WINCH CONTROL

Lower and raise the hook block quickly. With remote winch control on the TC700, the winch can be operated from any location. (OPTIONAL)



Operator cab tilts from 0° to 20° for a comfortable, clear view of the load.

MAKE THE MOST OF YOUR INVESTMENT

Unlike most 70-ton models on the market today, the TC700 is designed to be used with a commercial carrier, so operators can:

- Travel to and between job sites at highway speed. (Suggested minimum chassis specification is 500 hp/16-1800 lbs./ft.)
- Ride in comfort with a carrier suspension designed for highway driving.
- Get repairs done quickly and by qualified technicians at commercial truck service centers.
- Extend the life of the crane by replacing only the chassis when necessary.



RANGE DIAGRAM

- RANGE DIAGRAM -

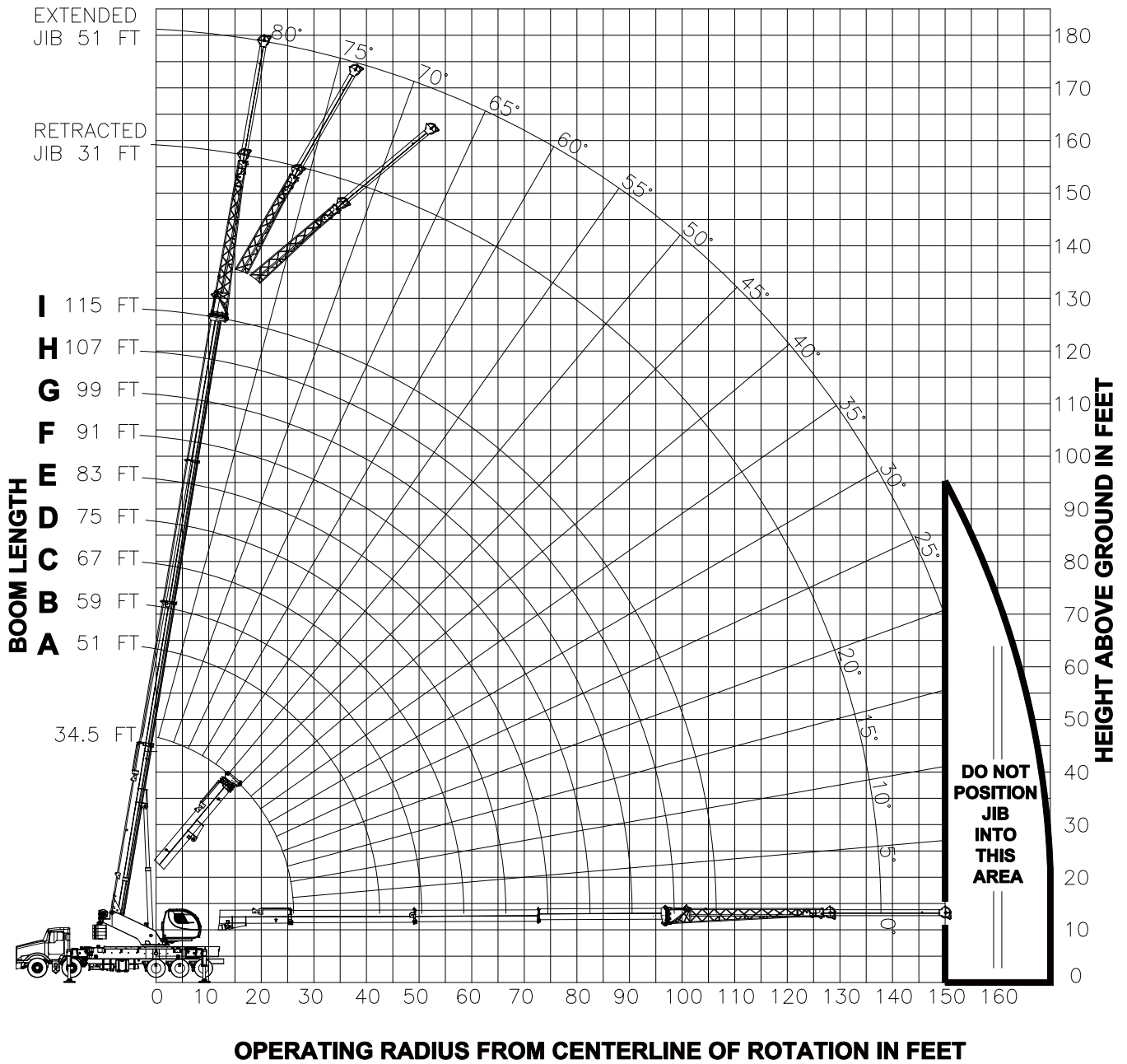

Data published herein is intended as a guide only. Crane operation is subject to the computer charts and operation manual supplied with the crane.







LOAD CHART: Main Boom





Lifting Capacities 4 Section Boom 34.5 ft. - 115 ft.

 16,500 lb.

 23 ft. 10 in.

 360°

70 Ton	34.5 ft. Boom		51 ft. Boom		59 ft. Boom		67 ft. Boom		75 ft. Boom		83 ft. Boom	
		360° Deg (lbs.)		360° Deg (lbs.)		360° Deg (lbs.)		360° Deg (lbs.)		360° Deg (lbs.)		360° Deg (lbs.)
8 ft.	67.0	140,000	75.4	80,000	77.5	77,200	79.6	74,600				
10 ft.	63.2	140,000	73.0	80,000	75.5	75,200	77.9	70,800				
12 ft.	59.2	105,750	70.6	80,000	73.5	73,150	76.2	67,150	78.0	60,400		
15 ft.	52.8	87,100	66.8	78,400	70.5	69,500	73.6	61,900	75.7	56,350	77.7	51,450
20 ft.	40.2	63,150	60.2	62,800	64.6	57,700	69.0	53,700	71.6	49,400	74.2	45,900
25 ft.	19.5	48,300	53.0	50,000	58.0	47,850	64.2	46,220	67.5	43,150	70.6	40,770
30 ft.			44.9	39,800	52.0	39,600	59.0	39,500	62.9	37,500	66.8	36,000
35 ft.			35.1	32,370	44.0	32,800	53.6	33,470	58.6	32,350	62.8	31,570
40 ft.			21.4	27,500	35.6	27,600	47.5	28,200	53.1	27,800	58.6	27,500
45 ft.					24.0	22,700	40.8	23,650	48.0	23,750	54.2	23,900
50 ft.							32.7	19,850	42.6	20,150	49.4	20,600
55 ft.							21.9	16,800	36.0	17,150	44.1	17,700
60 ft.									27.7	13,750	38.3	15,150
65 ft.											31.4	13,000
70 ft.											22.5	11,200
75 ft.											10.0	9,800
		1,460 lbs.	990 lbs.		860 lbs.		750 lbs.		670 lbs.		610 lbs.	
STOWED JIB DEDUCTIONS FOR MAIN BOOM CAPACITIES												

70 Ton	91 ft. Boom		99 ft. Boom		107 ft. Boom		115 ft. Boom	
		360° Deg (lbs.)		360° Deg (lbs.)		360° Deg (lbs.)		360° Deg (lbs.)
15 ft.	79.0	46,000						
20 ft.	75.9	41,550	77.6	37,850	78.6	33,650		
25 ft.	72.6	37,250	74.7	34,370	76.0	32,000	77.6	30,020
30 ft.	69.3	33,250	71.7	31,100	73.5	29,100	75.2	27,500
35 ft.	65.8	29,500	68.7	28,000	70.6	26,350	72.7	25,070
40 ft.	62.0	26,100	65.4	25,100	67.8	23,750	70.1	22,750
45 ft.	58.1	23,000	62.0	22,400	64.7	21,350	67.3	20,600
50 ft.	54.0	20,200	58.5	19,900	61.5	19,100	64.5	18,550
55 ft.	49.4	17,450	54.7	17,550	58.2	17,050	61.6	16,700
60 ft.	44.6	15,000	50.8	15,450	54.7	15,100	58.5	14,900
65 ft.	39.0	12,900	46.5	13,400	50.9	13,250	55.2	13,300
70 ft.	32.2	11,100	41.8	11,700	46.8	11,550	51.8	11,800
75 ft.	23.4	9,600	36.7	10,200	42.5	10,100	48.2	10,400
80 ft.	17.6	8,350	30.7	8,950	37.6	8,800	44.4	9,200
85 ft.			23.1	7,800	31.7	7,700	40.2	8,050
90 ft.			9.5	6,900	22.5	6,500	35.5	7,000
95 ft.					19.0	5,850	30.2	6,150
100 ft.							23.7	5,450
105 ft.							13.6	4,750
		560 lbs.	510 lbs.		470 lbs.		440 lbs.	
STOWED JIB DEDUCTIONS FOR MAIN BOOM CAPACITIES								

NOTES:

- All loads rated at 360° pick
- Loads based on crane on outriggers
- All "on outriggers" loads are based on 85% tipping
- Loads above heavy line are based on structural rating
- Loads below heavy line are based on tipping rating

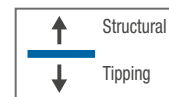

Data published herein is intended as a guide only. Crane operation is subject to the computer charts and operation manual supplied with the crane.









LOAD CHART: Main Boom





Lifting Capacities 4 Section Boom 34.5 ft. - 115 ft.

 11,000 lbs.

 23 ft. 10 in.

 360°

70 Ton	34.5 ft. Boom		51 ft. Boom		59 ft. Boom		67 ft. Boom		75 ft. Boom		83 ft. Boom	
		360° Deg (lbs.)		360° Deg (lbs.)		360° Deg (lbs.)		360° Deg (lbs.)		360° Deg (lbs.)		360° Deg (lbs.)
8 ft.	67.0	132,300	75.4	80,000	77.5	77,200	79.6	74,600				
10 ft.	63.2	120,000	73.0	80,000	75.5	75,200	77.9	70,800				
12 ft.	59.2	104,100	70.6	80,000	73.5	73,150	76.2	67,150	78.0	60,400		
15 ft.	52.8	83,700	66.8	78,400	70.5	69,500	73.6	61,900	75.7	56,350	77.7	51,450
20 ft.	40.2	59,000	60.2	62,050	64.6	57,100	69.0	53,250	71.6	49,200	74.2	45,900
25 ft.	19.5	45,610	53.0	48,210	58.0	46,350	64.2	44,940	67.5	42,350	70.6	40,360
30 ft.			44.9	38,100	52.0	38,150	59.0	38,300	62.9	37,000	66.8	36,000
35 ft.			35.1	30,190	44.0	30,750	53.6	31,680	58.6	30,950	62.8	30,440
40 ft.			21.4	25,700	35.6	24,900	47.5	26,450	53.1	26,200	58.6	26,050
45 ft.					24.0	19,850	40.8	21,700	48.0	21,750	54.2	21,900
50 ft.							32.7	17,750	42.6	17,950	49.4	18,300
55 ft.							21.9	14,600	36.0	14,800	44.1	15,200
60 ft.									27.7	12,100	38.3	12,800
65 ft.											31.4	10,900
70 ft.											22.5	9,300
75 ft.											10.0	8,000
	1,460 lbs.		990 lbs.		860 lbs.		750 lbs.		670 lbs.		610 lbs.	
STOWED JIB DEDUCTIONS FOR MAIN BOOM CAPACITIES												

70 Ton	91 ft. Boom		99 ft. Boom		107 ft. Boom		115 ft. Boom	
		360° Deg (lbs.)		360° Deg (lbs.)		360° Deg (lbs.)		360° Deg (lbs.)
15 ft.	79.0	46,000						
20 ft.	75.9	41,550	77.6	37,850	78.6	33,650		
25 ft.	72.6	36,850	74.7	34,030	76.0	31,750	77.6	29,720
30 ft.	69.3	33,250	71.7	31,100	73.5	29,100	75.2	27,500
35 ft.	65.8	28,600	68.7	27,250	70.6	25,750	72.7	24,570
40 ft.	62.0	24,950	65.4	24,200	67.8	23,100	70.1	22,300
45 ft.	58.1	21,500	62.0	21,200	64.7	20,450	67.3	19,950
50 ft.	54.0	18,350	58.5	18,400	61.5	18,000	64.5	17,750
55 ft.	49.4	15,450	54.7	15,850	58.2	15,750	61.6	15,700
60 ft.	44.6	13,100	50.8	13,550	54.7	13,650	58.5	13,800
65 ft.	39.0	11,100	46.5	11,550	50.9	11,650	55.2	11,950
70 ft.	32.2	9,400	41.8	9,800	46.8	9,950	51.8	10,350
75 ft.	23.4	8,000	36.7	8,400	42.5	8,550	48.2	8,900
80 ft.	17.6	6,600	30.7	7,200	37.6	7,300	44.4	7,700
85 ft.			23.1	6,200	31.7	6,250	40.2	6,600
90 ft.			9.5	5,300	22.5	5,200	35.5	5,600
95 ft.					19.0	4,400	30.2	4,800
100 ft.							23.7	4,100
105 ft.							13.6	3,600
	560 lbs.		510 lbs.		470 lbs.		440 lbs.	
STOWED JIB DEDUCTIONS FOR MAIN BOOM CAPACITIES								

NOTES:

- All loads rated at 360° pick
- Loads based on crane on outriggers
- All "on outriggers" loads are based on 85% tipping
- Loads above heavy line are based on structural rating
- Loads below heavy line are based on tipping rating

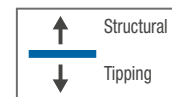

Data published herein is intended as a guide only. Crane operation is subject to the computer charts and operation manual supplied with the crane.







LOAD CHART: Main Boom





Lifting Capacities 4 Section Boom 34.5 ft. - 115 ft.

 5,500 lb.

 23 ft. 10 in.

 360°

70 Ton	34.5 ft. Boom		51 ft. Boom		59 ft. Boom		67 ft. Boom		75 ft. Boom		83 ft. Boom	
		360° Deg (lbs.)		360° Deg (lbs.)		360° Deg (lbs.)		360° Deg (lbs.)		360° Deg (lbs.)		360° Deg (lbs.)
8 ft.	67.0	132,300	75.4	80,000	77.5	77,200	79.6	74,600				
10 ft.	63.2	120,000	73.0	80,000	75.5	75,200	77.9	70,800				
12 ft.	59.2	102,750	70.6	80,000	73.5	73,150	76.2	67,150	78.0	60,400		
15 ft.	52.8	81,000	66.8	78,400	70.5	69,500	73.6	61,900	75.7	56,350	77.7	51,450
20 ft.	40.2	55,700	60.2	60,600	64.6	56,700	69.0	52,800	71.6	49,000	74.2	45,900
25 ft.	21.9	43,900	53.0	47,000	58.0	44,300	64.0	44,100	67.5	42,000	70.3	40,360
30 ft.			44.9	36,800	52.0	36,500	59.0	37,150	62.9	36,500	66.8	36,000
35 ft.			35.4	28,210	44.0	27,900	53.4	30,120	58.6	29,750	62.8	29,500
40 ft.			21.4	22,900	35.6	22,300	47.5	24,000	53.1	23,600	58.6	24,300
45 ft.					24.0	17,600	40.8	19,400	48.0	19,550	54.2	19,600
50 ft.							32.7	15,900	42.6	15,750	49.4	15,600
55 ft.							21.9	12,900	36.0	13,400	44.1	13,400
60 ft.									27.7	10,350	38.3	11,200
65 ft.											31.4	9,500
70 ft.											22.5	8,000
75 ft.											10.0	6,800
		1,460 lbs.	990 lbs.		860 lbs.		750 lbs.		670 lbs.		610 lbs.	
STOWED JIB DEDUCTIONS FOR MAIN BOOM CAPACITIES												

70 Ton	91 ft. Boom		99 ft. Boom		107 ft. Boom		115 ft. Boom	
		360° Deg (lbs.)		360° Deg (lbs.)		360° Deg (lbs.)		360° Deg (lbs.)
15 ft.	79.0	46,000						
20 ft.	75.9	41,550	77.6	37,850	78.6	33,650		
25 ft.	72.6	36,850	74.7	34,030	76.0	31,750	77.6	29,720
30 ft.	69.3	33,250	71.7	31,100	73.5	29,100	75.2	27,500
35 ft.	65.8	27,850	68.7	26,600	70.6	25,200	72.7	24,100
40 ft.	62.0	23,550	65.4	23,000	67.8	22,100	70.1	21,400
45 ft.	58.1	19,550	62.0	19,500	64.7	19,050	67.3	18,700
50 ft.	54.0	15,900	58.5	16,400	61.5	16,250	64.5	16,200
55 ft.	49.4	13,500	54.7	13,700	58.2	13,750	61.6	13,900
60 ft.	44.6	11,300	50.8	11,500	54.7	11,600	58.5	11,800
65 ft.	39.0	9,400	46.5	9,800	50.9	9,850	55.2	10,000
70 ft.	32.2	7,800	41.8	8,400	46.8	8,400	51.8	8,600
75 ft.	23.4	6,400	36.7	7,100	42.5	7,000	48.2	7,400
80 ft.	17.6	5,300	30.7	6,000	37.6	5,900	44.4	6,100
85 ft.			23.1	5,000	31.7	4,800	40.2	5,200
90 ft.			9.5	4,100	22.5	3,800	35.5	4,200
95 ft.					19.0	3,400	30.2	3,500
100 ft.							23.7	2,800
105 ft.							13.6	2,200
		560 lbs.	510 lbs.		470 lbs.		440 lbs.	
STOWED JIB DEDUCTIONS FOR MAIN BOOM CAPACITIES								

NOTES:

- All loads rated at 360° pick
- Loads based on crane on outriggers
- All "on outriggers" loads are based on 85% tipping
- Loads above heavy line are based on structural rating
- Loads below heavy line are based on tipping rating

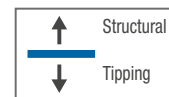

Data published herein is intended as a guide only. Crane operation is subject to the computer charts and operation manual supplied with the crane.





LOAD CHART: Main Boom and Jib

 16,500 lb.



 23 ft. 10 in.

 360°

Lifting Capacities - 31 ft. Retracted Jib

Load Radius	0° Offset		20° Offset		40° Offset	
		Over Rear (lbs.)		Over Rear (lbs.)		Over Rear (lbs.)
35 ft.	76.4	11,000				
40 ft.	74.2	10,800	78.3	8,850		
45 ft.	72.0	10,600	76.1	8,600	79.4	6,600
50 ft.	69.8	10,350	73.8	8,350	77.1	6,400
55 ft.	67.6	9,900	71.5	8,100	74.8	6,300
60 ft.	65.3	9,250	69.2	7,800	72.4	6,150
65 ft.	63.0	8,600	66.9	7,250	69.9	6,050
70 ft.	60.6	7,950	64.5	6,850	67.4	5,900
75 ft.	58.2	7,400	62.0	6,500	64.8	5,800
80 ft.	55.7	6,950	59.5	6,250	62.2	5,650
85 ft.	53.1	6,300	56.8	6,050	59.4	5,500
90 ft.	50.4	5,700	54.1	5,700	56.6	5,350
95 ft.	47.6	5,000	51.3	5,200	53.6	5,050
100 ft.	44.7	4,300	48.4	4,650	50.5	4,650
105 ft.	41.7	3,800	45.2	4,000	47.1	4,000
110 ft.	38.4	3,200	41.9	3,400	43.5	3,500
115 ft.	34.9	2,650	38.3	2,850	39.5	3,000
120 ft.	31.1	2,200	34.3	2,400	35.1	2,400
125 ft.	26.8	1,750	29.9	1,850	29.7	1,850
130 ft.	21.7	1,300	24.3	1,400		
135 ft.	15.0	900	16.8	900		
140 ft.						
145 ft.						
150 ft.						
155 ft.						

Lifting Capacities - 53 ft. Extended Jib



Load Radius	0° Offset		20° Offset		40° Offset	
		Over Rear (lbs.)		Over Rear (lbs.)		Over Rear (lbs.)
35 ft.	78.2	7,000				
40 ft.	76.3	6,800				
45 ft.	74.5	6,600				
50 ft.	72.6	6,400	78.6	4,750		
55 ft.	70.6	6,150	76.6	4,600		
60 ft.	68.7	5,950	74.7	4,500		
65 ft.	66.7	5,750	72.7	4,350	77.7	3,350
70 ft.	64.7	5,550	70.7	4,250	75.6	3,300
75 ft.	62.7	5,300	68.6	4,100	73.4	3,200
80 ft.	60.6	5,100	66.5	3,950	71.2	3,150
85 ft.	58.5	4,900	64.3	3,850	68.9	3,050
90 ft.	56.4	4,700	62.1	3,700	66.6	3,000
95 ft.	54.2	4,500	59.9	3,600	64.2	2,950
100 ft.	51.9	4,250	57.6	3,450	61.7	2,900
105 ft.	49.5	4,050	55.2	3,300	59.2	2,800
110 ft.	47.1	3,850	52.7	3,200	56.5	2,750
115 ft.	44.6	3,650	50.1	3,050	53.6	2,700
120 ft.	41.9	3,200	47.3	2,950	50.6	2,650
125 ft.	39.1	2,750	44.4	2,800	47.4	2,600
130 ft.	36.1	2,200	41.3	2,650	43.9	2,500
135 ft.	32.9	2,000	38.0	2,100	40.1	2,200
140 ft.	29.4	1,450	34.3	1,550	35.6	1,550
145 ft.	25.5	1,200	30.1	1,300	30.1	1,300
150 ft.	20.8	900	25.0	1,000	22.0	1,000
155 ft.						

Data published herein is intended as a guide only. Crane operation is subject to the computer charts and operation manual supplied with the crane.



LOAD CHART: Main Boom and Jib

 11,000 lbs.  23 ft. 10 in.  360°

Lifting Capacities - 31 ft. Retracted Jib

Load Radius	0° Offset		20° Offset		40° Offset	
		Over Rear (lbs.)		Over Rear (lbs.)		Over Rear (lbs.)
35 ft.	76.4	11,000				
40 ft.	74.2	10,800	78.3	8,850		
45 ft.	72.0	10,600	76.1	8,600	79.4	6,600
50 ft.	69.8	10,350	73.8	8,350	77.1	6,400
55 ft.	67.6	9,900	71.5	8,100	74.8	6,300
60 ft.	65.3	9,250	69.2	7,800	72.4	6,150
65 ft.	63.0	8,600	66.9	7,250	69.9	6,050
70 ft.	60.6	7,950	64.5	6,850	67.4	5,900
75 ft.	58.2	7,100	62.0	6,500	64.8	5,800
80 ft.	55.7	6,100	59.5	6,250	62.2	5,650
85 ft.	53.1	5,400	56.8	5,800	59.4	5,500
90 ft.	50.4	4,700	54.1	4,800	56.6	5,350
95 ft.	47.6	4,000	51.3	4,300	53.6	4,600
100 ft.	44.7	3,300	48.4	3,750	50.5	3,800
105 ft.	41.7	2,900	45.2	3,050	47.1	3,100
110 ft.	38.4	2,300	41.9	2,500	43.5	2,550
115 ft.	34.9	1,750	38.3	1,950	39.5	2,000
120 ft.	31.1	1,300	34.3	1,550	35.1	1,550
125 ft.	26.8	900	29.9	1,000	29.7	1,000
130 ft.						
135 ft.						
140 ft.						
145 ft.						
150 ft.						
155 ft.						

Lifting Capacities - 53 ft. Extended Jib

Load Radius	0° Offset		20° Offset		40° Offset	
		Over Rear (lbs.)		Over Rear (lbs.)		Over Rear (lbs.)
35 ft.	78.2	7,000				
40 ft.	76.3	6,800				
45 ft.	74.5	6,600				
50 ft.	72.6	6,400	78.6	4,750		
55 ft.	70.6	6,150	76.6	4,600		
60 ft.	68.7	5,950	74.7	4,500		
65 ft.	66.7	5,750	72.7	4,350	77.7	3,350
70 ft.	64.7	5,550	70.7	4,250	75.6	3,300
75 ft.	62.7	5,300	68.6	4,100	73.4	3,200
80 ft.	60.6	5,100	66.5	3,950	71.2	3,150
85 ft.	58.5	4,900	64.3	3,850	68.9	3,050
90 ft.	56.4	4,700	62.1	3,700	66.6	3,000
95 ft.	54.2	4,500	59.9	3,600	64.2	2,950
100 ft.	51.9	4,250	57.6	3,450	61.7	2,900
105 ft.	49.5	3,700	55.2	3,300	59.2	2,800
110 ft.	47.1	3,100	52.7	3,200	56.5	2,750
115 ft.	44.6	2,800	50.1	3,050	53.6	2,700
120 ft.	41.9	2,500	47.3	2,800	50.6	2,650
125 ft.	39.1	1,900	44.4	2,250	47.4	2,600
130 ft.	36.1	1,350	41.3	2,000	43.9	1,800
135 ft.	32.9	1,150	38.0	1,450	40.1	1,350
140 ft.			34.3	900	35.6	900
145 ft.						
150 ft.						
155 ft.						

Data published herein is intended as a guide only. Crane operation is subject to the computer charts and operation manual supplied with the crane.





LOAD CHART: Main Boom and Jib

— 5,500 lb.



— 23 ft. 10 in.

360°

Lifting Capacities - 31 ft. Retracted Jib

Load Radius	0° Offset		20° Offset		40° Offset	
		Over Rear (lbs.)		Over Rear (lbs.)		Over Rear (lbs.)
35 ft.	76.4	11,000				
40 ft.	74.2	10,800	78.3	8,850		
45 ft.	72.0	10,600	76.1	8,600	79.4	6,600
50 ft.	69.8	10,350	73.8	8,350	77.1	6,400
55 ft.	67.6	9,900	71.5	8,100	74.8	6,300
60 ft.	65.3	9,250	69.2	7,800	72.4	6,150
65 ft.	63.0	8,000	66.9	7,250	69.9	6,050
70 ft.	60.6	7,000	64.5	6,850	67.4	5,900
75 ft.	58.2	6,000	62.0	6,400	64.8	5,800
80 ft.	55.7	5,000	59.5	5,600	62.2	5,400
85 ft.	53.1	4,300	56.8	4,800	59.4	5,200
90 ft.	50.4	3,700	54.1	4,000	56.6	4,400
95 ft.	47.6	2,900	51.3	3,400	53.6	3,700
100 ft.	44.7	2,400	48.4	2,800	50.5	2,800
105 ft.	41.7	1,800	45.2	2,000	47.1	2,100
110 ft.	38.4	1,300	41.9	1,500	43.5	1,500
115 ft.			38.3	900	39.5	1,000
120 ft.						
125 ft.						
130 ft.						
135 ft.						
140 ft.						
145 ft.						
150 ft.						
155 ft.						

Lifting Capacities - 53 ft. Extended Jib

Load Radius	0° Offset		20° Offset		40° Offset	
		Over Rear (lbs.)		Over Rear (lbs.)		Over Rear (lbs.)
35 ft.	78.2	7,000				
40 ft.	76.3	6,800				
45 ft.	74.5	6,600				
50 ft.	72.6	6,400	78.6	4,750		
55 ft.	70.6	6,150	76.6	4,600		
60 ft.	68.7	5,950	74.7	4,500		
65 ft.	66.7	5,750	72.7	4,350	77.7	3,350
70 ft.	64.7	5,550	70.7	4,250	75.6	3,300
75 ft.	62.7	5,300	68.6	4,100	73.4	3,200
80 ft.	60.6	5,100	66.5	3,950	71.2	3,150
85 ft.	58.5	4,900	64.3	3,850	68.9	3,050
90 ft.	56.4	4,400	62.1	3,700	66.6	3,000
95 ft.	54.2	3,900	59.9	3,600	64.2	2,950
100 ft.	51.9	3,300	57.6	3,450	61.7	2,900
105 ft.	49.5	2,800	55.2	3,300	59.2	2,800
110 ft.	47.1	2,300	52.7	2,900	56.5	2,750
115 ft.	44.6	2,000	50.1	2,300	53.6	2,700
120 ft.	41.9	1,500	47.3	2,000	50.6	2,300
125 ft.	39.1	1,100	44.4	1,450	47.4	1,800
130 ft.			41.3	1,200	43.9	1,400
135 ft.					40.1	950
140 ft.						
145 ft.						
150 ft.						
155 ft.						

Data published herein is intended as a guide only. Crane operation is subject to the computer charts and operation manual supplied with the crane.

CRANE DIMENSIONS

TC700 ON KW T800

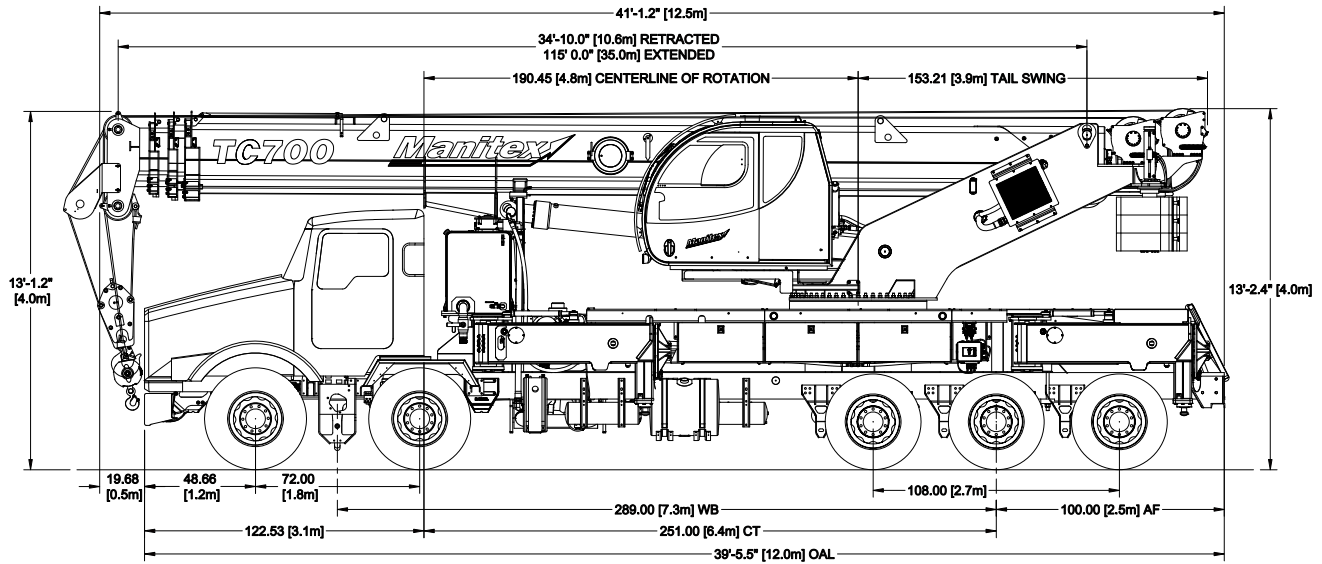

SUGGESTED CHASSIS DATA

KENWORTH T800

Minimum Chassis Requirements	lbs.	kg	Gross Vehicle Weight	lbs.	kg
Gross vehicle weight rating*	109,000	49,440	Base machine**	80,500	36,514
Front axle weight rating	40,000	31,298	Gross vehicle weight*	102,500	46,493
Rear axle weight rating	69,000	31,298	Front axle weight	35,600	16,148
			Rear axle weight	66,900	30,345
Chassis Dimensions	in.	m	Estimated Minimum Chassis Weight		
Wheelbase	289	7.3	Front axle	14,900	6,759
Cab to axle	251	6.4	Tridem axles	12,400	5,625
After frame	100	2.5	Total weight	27,300	12,383
Frame height (unloaded)	42	1.07			
Minimum Frame per Rail - RBM	lb./in.				
	3,468,000				



* Weight with auxiliary winch, jib and full (16,500 lbs.) CWT
(CWT to travel must be stored with half on turret and half on subframe)

** Auxiliary winch, jib, zero added counterweight

*** Without auxiliary winch and jib

Other Chassis Applications available. Please Consult Factory

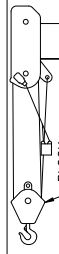
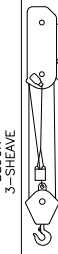
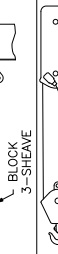
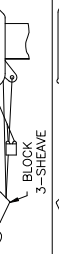
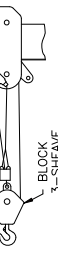
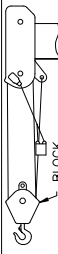
REEVING DIAGRAM

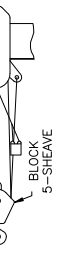
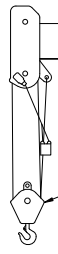
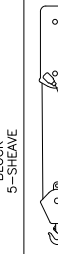
ALLOWABLE LINE PULL												WARNING
1 PART LINE	2 PART LINE	3 PART LINE	4 PART LINE	5 PART LINE	6 PART LINE	7 PART LINE	8 PART LINE	9 PART LINE	10 PART LINE	11 PART LINE	12 PART LINE	
												<p>ANTI-TWO-BLOCK SYSTEM MUST BE IN GOOD OPERATING CONDITION BEFORE OPERATING CRANE.</p> <p>REFER TO THE OWNER'S MANUAL.</p> <p>KEEP AT LEAST 3 WRAPS OF LOAD LINE ON THE DRUM AT ALL TIMES.</p>
12000 LBS	24000 LBS	36000 LBS	48000 LBS	60000 LBS	72000 LBS	84000 LBS	96000 LBS	108000 LBS	120000 LBS	132000 LBS	140000 LBS	

OUTRIGGER EXTENSION

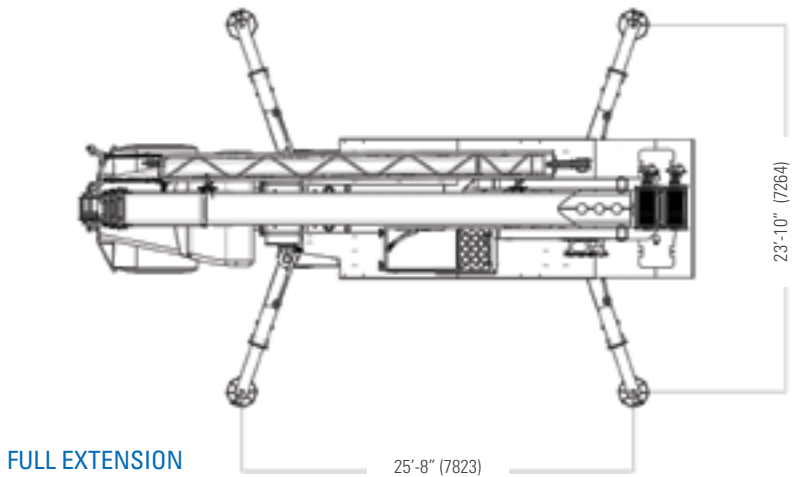
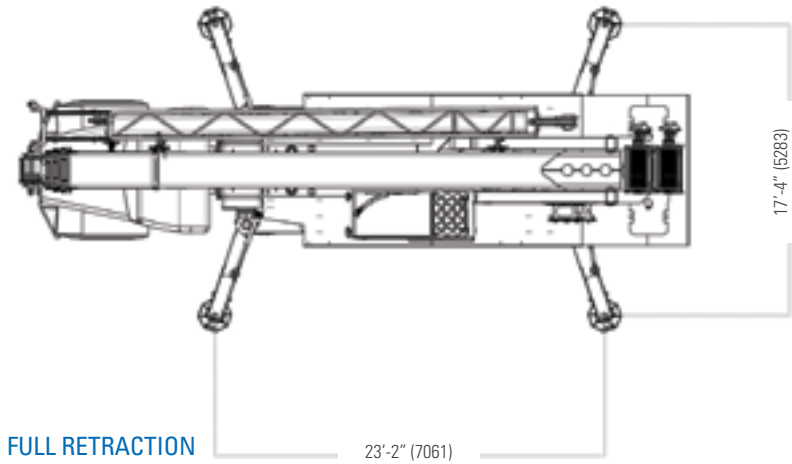

AREA OF OPERATION

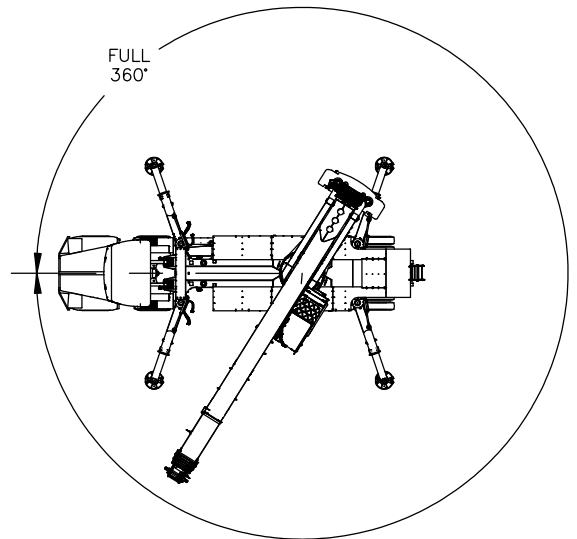

TECHNICAL DESCRIPTIONS

Boom



Boom length: 38.5 ft. (11.8 m)
 Extended boom length: 115 ft. (35 m)



Boom max. tip height: 125 ft. (38.1 m)



Boom angle (min/max): -4°/80°

Rotation



Slewing speed: 0-2.0 rev./min.



Slewing brake: Free swing (pedal applied)
 Auto Brake - Spring applied hydraulically released



Boom rotation: 360° continuous

Outriggers



Outrigger: X-Pattern

Max.

- Front and rear:
 Swing, out and down to outer edge of pad: 25 ft. 9.5 in. (7.9 m)

Min.

- Front and rear:
 Swing, out and down to outer edge of pad: 19 ft. 3 in. (5.9 m)

Stowed

- Front and rear:
 6 ft. 3 in. (2.0 m)



ROCSolid-Radio operated hand-held controller for outrigger and winch control

Hoist, Rope and Hook



Winch speed:

First layer

- Low speed - 147.6 fpm (45 m/min)
- High speed - 295.2 fpm (90 m/min)

Fifth layer

- Low speed - 192 fpm (58.5 m/min)
- High speed - 384 fpm (117 m/min)



Max. line pull:

First layer

- Low speed - 14,500 lbs. (64.5 kN)
- High speed - 11,240 lbs. (50.0 kN)

Fifth layer

- Low speed - 7,080 lbs. (31.5 kN)
- High speed - 5,500 lbs. (24.5 kN)



Main & auxiliary winch cable diameter:
 5/8 in. (16 mm)



Line length: 662 ft. (202 m) Non-spin cable



Main & auxiliary winch: Bent axis 2-speed hydraulic motor



Hydraulics



Max. system pressure at: 4,600 psi (320 bar)

Working system pressure: 3,625 psi (250 bar)

Hydraulic tank capacity: 220 gal. (832.8 L)

Pumps:

- 1 x Load sense piston pump rated at: 77 gpm (290 lpm)
- 1 x Gear pump rated at: 23 gpm (88 lpm)
- Full flow with bypass protection
- Return: 10 micron filter
- Full proportional control valves

TECHNICAL DESCRIPTIONS

Cab/Cab Controls



Joystick control, 2 Dual-Axis with four simulations functions.



Boom extend/retract – slider thumb-switch

Boom hoist/lower

Main and auxiliary winch (optional) with thumpers

Turret swing

Thumb slide switch for engine rpm

Foot pedal controls (engine rpm & swing brake)

Electric over hydraulic controls system using 12 V system controls with Parker IQAN CANBUS system



Swing lock switch

Crane cab air conditioner

Counterweight



Counterweights:

Main counterweight with integrated hydraulic mounting system

Hydraulic cylinders allow counterweights to be easily removed and attached without additional lifting devices for placement on the deck of the carrier.



• 1 x Counterweight: 5,500 lbs. (2,495 kg)



• 2 x Counterweight: 11,000 lbs. (4,990 kg)



• 3 x Counterweight: 16,500 lbs. (7,490 kg)

Operator Aids



- Wired LMI with crane function cut-offs for overload protection
- EMS - Engine Monitoring System
- Graphical display
- Event recorder
- WADS - Work Area Definition System
- Wired anti-two block system

Optional Equipment

Tool Box: Multiple configurations

Optional Equipment

Jib



Swing on jib, folded extension

Angular offset: 0°, 20°, 40°



Max. boom length with extension: 185 ft. (56.4 m)

Min. boom length with extension: 146 ft. (44.5 m)



Fixed length: 31 ft. (9.45 m)

Extended length: 51 ft. (16.1 m)

Hoist, Rope and Hook



Auxiliary head: Installs only to main boom. Must be removed to use the jib.



Auxiliary winch speed:

First layer

- Low speed - 147.6 fpm (45 m/min)
- High speed - 295.2 fpm (90 m/min)

Fifth layer

- Low speed - 192 fpm (58.5 m/min)
- High speed - 384 fpm (117 m/min)



Hook block - 45 T (40.8 mT)

Hook block - 50 T (45.4 mT)

Hook block - 60 T (54.4 mT) Quick Reeve

Hook block - 70 T (63.5 mT) Quick Reeve

Top swivel ball with hook and latch
7 T (6.4 mT)

Operator Aids



3rd Wrap limiter, main and auxiliary winch



4-Function radio remote crane control system

- 900 Mhz
- 433 Mhz



TC700

70-ton (63.5 mt) TELESCOPIC CRANE
TC700 SERIES PRODUCT GUIDE

Uptime is the Manitex commitment to complete support of thousands of units working every day.

MANITEX

3000 South Austin Avenue
Georgetown, Texas 78626

1-877-314-3390 | www.Manitex.com