Manual # 99904680

6/39 Technical Specifications

Revision Date 20111213



IOWA MOLD TOOLING CO., INC.

PO Box 189

Garner, IA 50438

Tel: 641-923-3711 FAX: 641-923-2424

Website: <http://www.imt.com>

Copyright © 2009 Iowa Mold Tooling Co., Inc.
All rights reserved

No part of this publication may be reproduced, stored in a retrieval system, or transmitted in any form or by any means, electronic, mechanical, photocopying, recording or otherwise without the prior written permission of Iowa Mold Tooling Co., Inc.

Iowa Mold Tooling Co., Inc. is an Oshkosh Corporation company.

Contents

Revisions	ii
Technical Data and Charts	3
6/39 Specifications.....	3
6/39 Pressure Settings.....	5
6/39 K1 Capacity Chart	6
6/39 K2 Capacity Chart	7
6/39 K3 Capacity Chart	8
6/39 K4 Capacity Chart	9
6/39 Geometric Configuration	10
Hydraulic Schematics	11
Hydraulic Diagram - 6/39 Standard	12
Hydraulic Diagram - 6/39 with Extra Valves	13
Hydraulic Diagram - 6/39 with Winch	14
Hydraulic Diagram - 6/39 Hydrocontrol M50 - Radio	15
Hydraulic Diagram - 6/39 Danfoss PVG32	16

Revisions

DATE	LOCATION	DESCRIPTION
20111213	SPECS	ECN 11628 – Updated stabilizer wording.

CHAPTER 1

Technical Data and Charts

In This Chapter

6/39 Specifications	3
6/39 Pressure Settings	4
6/39 K1 Capacity Chart	6
6/39 K2 Capacity Chart	7
6/39 K3 Capacity Chart	8
6/39 K4 Capacity Chart	9
6/39 Geometric Configuration	10

6/39 Specifications

6/39	1-HYDRAULIC	2-HYDRAULIC	3-HYDRAULIC	4-HYDRAULIC
Crane Rating*	39,060 ft-lb (5.4 tm)	37,610 ft-lb (5.2 tm)	36,890 ft-lb (5.1 tm)	34,720 ft-lb (4.8 tm)
Maximum Horizontal Reach	17' 1" (5.2 m)	23' 0" (7.0 m)	28' 7" (8.7 m)	34' 5" (10.5 m)
Maximum Vertical Reach	23' 4" (7.1 m)	29' 2" (8.9 m)	35' 1" (10.7 m)	41' 0" (12.5 m)
Maximum Capacity	3525 lb (1600 kg)	3305 lb (1500 kg)	3141 lb (1425 kg)	2920 lb (1325 kg)
Maximum Capacity at Maximum Reach	2370 lb (1075 kg)	1600 lb (725 kg)	1155 lb (525 kg)	880 lb (400 kg)
Crane Weight **	1630 lb (740 kg)	1795 lb (815 kg)	1940 lb (880 kg)	2070 lb (940 kg)
Hook Approach				
Vertical	8' 0" (2.44 m)	7' 8" (2.34 m)	7' 4" (2.23 m)	7' 0" (2.13 m)
Horizontal	2' 9" (0.84 m)	2' 11" (0.89 m)	3' 1" (0.94 m)	3' 3" (1.0 m)
Center of Gravity - Stored				
Vertical	1' 10" (561 mm)	1' 10" (566 mm)	1' 10" (570 mm)	1' 11" (573 mm)
Horizontal (C/L RotTo Bridge)	7.5" (190 mm)	7" (182 mm)	6.5" (165 mm)	6" (152 mm)

* Crane rating (ft-lb) is the rated load (lb) multiplied by the respective distance (ft) from centerline of rotation with all extensions retracted and the inner and outer booms in a horizontal position, per ANSI B30.22. ** Crane weight does not include stabilizers.

6/39 SPECIFICATIONS	
Stabilizer Pad Diameter	5.5" (140 mm)
Crane Storage Height	6' 1" (1843 mm)
Mounting Space***	1' 11" (583 mm)
Rotational Torque	7090 ft-lb (980 kgm)
Rotation	400°
Optimum Pump Performance	6.6 gpm (25 lpm)
System Pressure	3990 psi (275 bar)
Oil Reservoir Capacity	8.8 gal (33.5 l)
Stabilizer Extension Span	
Standard (manual out /hydraulic down)	11' 2" (3400 mm)
Weight	265 lb (120 kg)
Option 1 (manual out / hyd. down)	15' 7" (4760 mm)
Weight	340 lb (155 kg)
Option 2 (hyd. out / hyd. down)	18' 1" (5500 mm)
Weight	395 lb (180 kg)
*** Maximum swing clearance radius required is 22" (556 mm) at 7'-2" (2193 mm) from top of chassis frame.	

MINIMUM CHASSIS SPECIFICATIONS	
Front Axle Rating (GAWR)	6000 lb (2720 kg)
Rear Axle Rating (GAWR)	12,460 lb (5650 kg)
Resistance To Bending Moment	540,000 in-lb (62,215 kg-m)

6/39 Pressure Settings

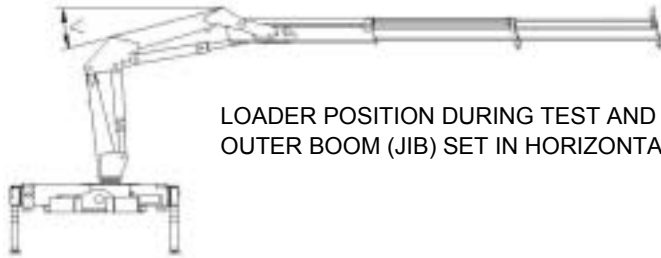

LOADER POSITION DURING TEST AND VALVE ADJUSTMENT:
OUTER BOOM (JIB) SET IN HORIZONTAL POSITION, V AT 15 DEG.

WORKING PRESSURE ON MAIN-RELIEF VALVES & PORT-RELIEF VALVES			
<i>Function</i>	<i>Direction</i>	<i>Port</i>	<i>Pressure (Loading Group 03)</i>
Main-Relief Valve			4000 psi (275 bar)
Rotation System	Left	A-port	2175 psi (150 bar)
	Right	B-port	2175 psi (150 bar)
Extension Cylinders	Extend	A-port	P
	Retract	B-port	P
Jib Cylinder	Down	A-port	2900 psi (200 bar)
	Up	B-port	4280 psi (295 bar)
Boom Cylinder	Up	A-port	4280 psi (295 bar)
	Down	B-port	1450 psi (100 bar)
Grab, Winch, Rotator	Down	A-port	2540 psi (175 bar)
	Up	B-port	2540 psi (175 bar)
	Down	A-port	2540 psi (175 bar)
	Up	B-port	2540 psi (175 bar)
Winch (Pullmaster PL1)	Retract	A-port	2030 psi (140 bar)
	Extend	B-port	2030 psi (140 bar)
Winch (Pullmaster PL2)	Retract	A-port	2250 psi (155 bar)
	Extend	B-port	2250 psi (155 bar)
Separate Stabilizer Valve			2175 bar (150 bar)

OPENING PRESSURE ON LOAD-HOLDING VALVES

Boom Cylinder	4425 psi (305 bar)
Jib Cylinder	4495 psi (310 bar)
Extension Cylinder	3045 psi (210 bar)
Re-generation	6235 psi (430 bar)

PRESSURE SETTING

Pressure Setting for Load-Moment Limitation	3845 psi (265 bar)
---	--------------------

MAXIMUM PUMP PERFORMANCE

Pump Performance 6/39 K1 & K2	6.6 gpm (25 l/min)
Pump Performance 6/39 K3 & K4	5.3 gpm (20 l/min)

NOTE: On Hydrocontrol M50, the A-port is located next to the control lever.

6/39 K1 Capacity Chart

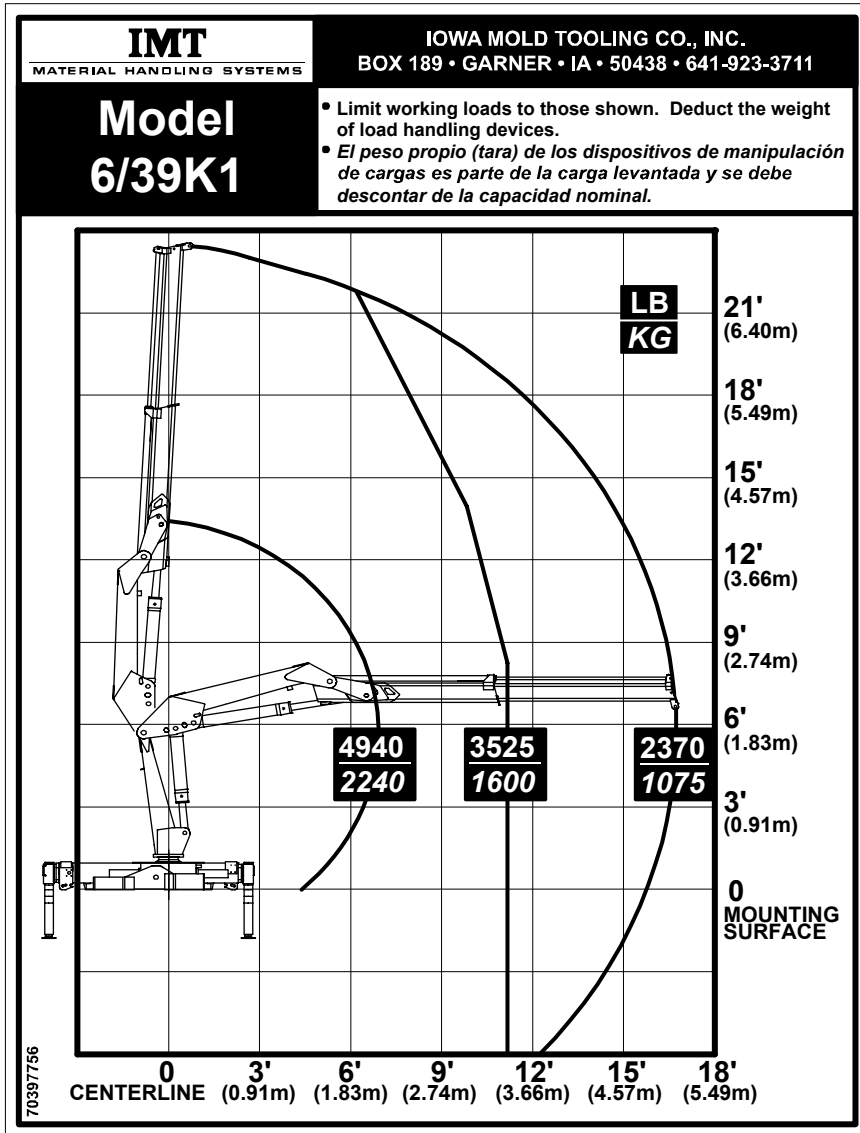

6/39 K2 Capacity Chart

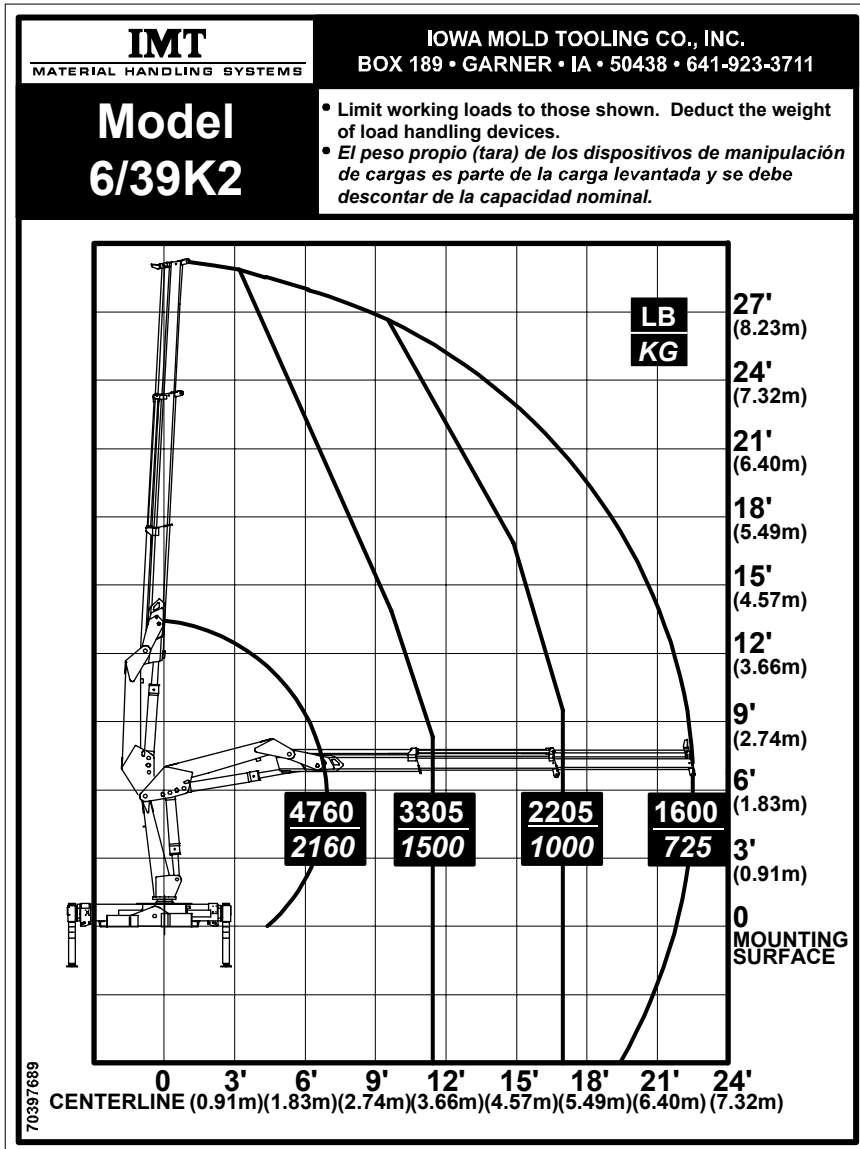

6/39 K3 Capacity Chart

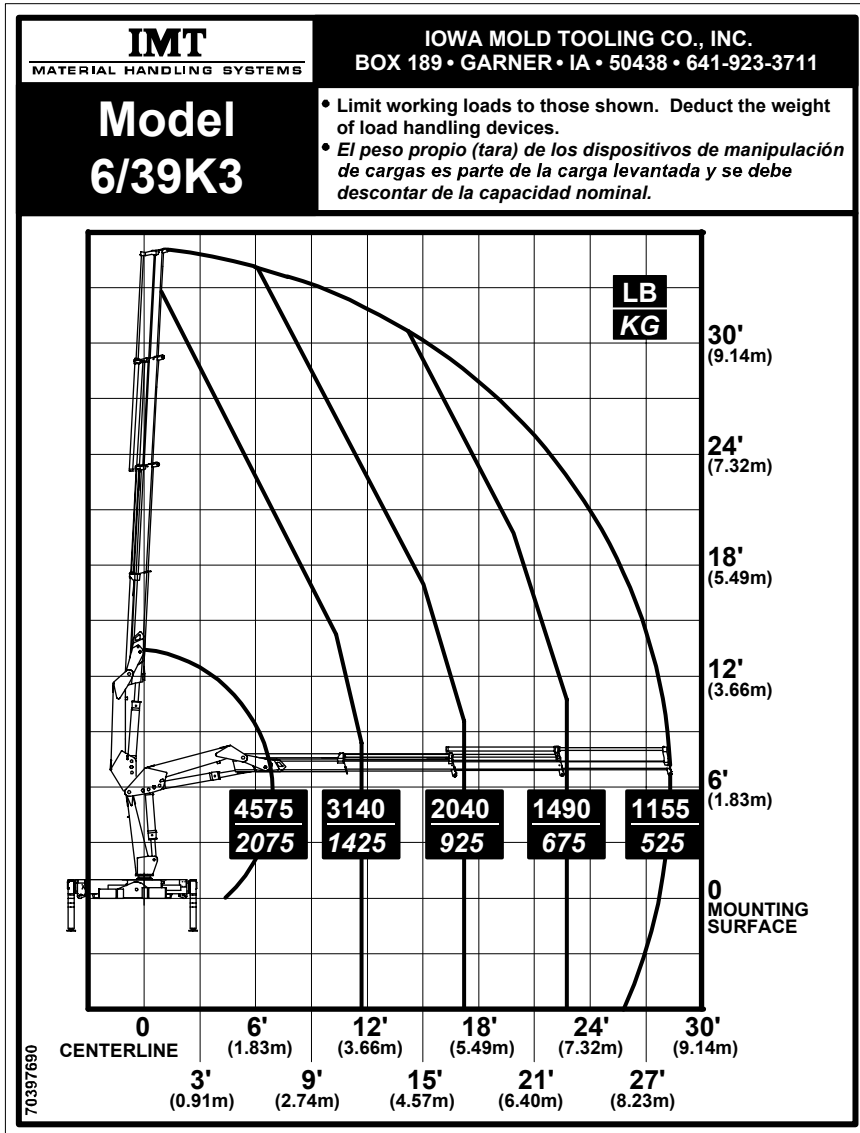

6/39 Geometric Configuration

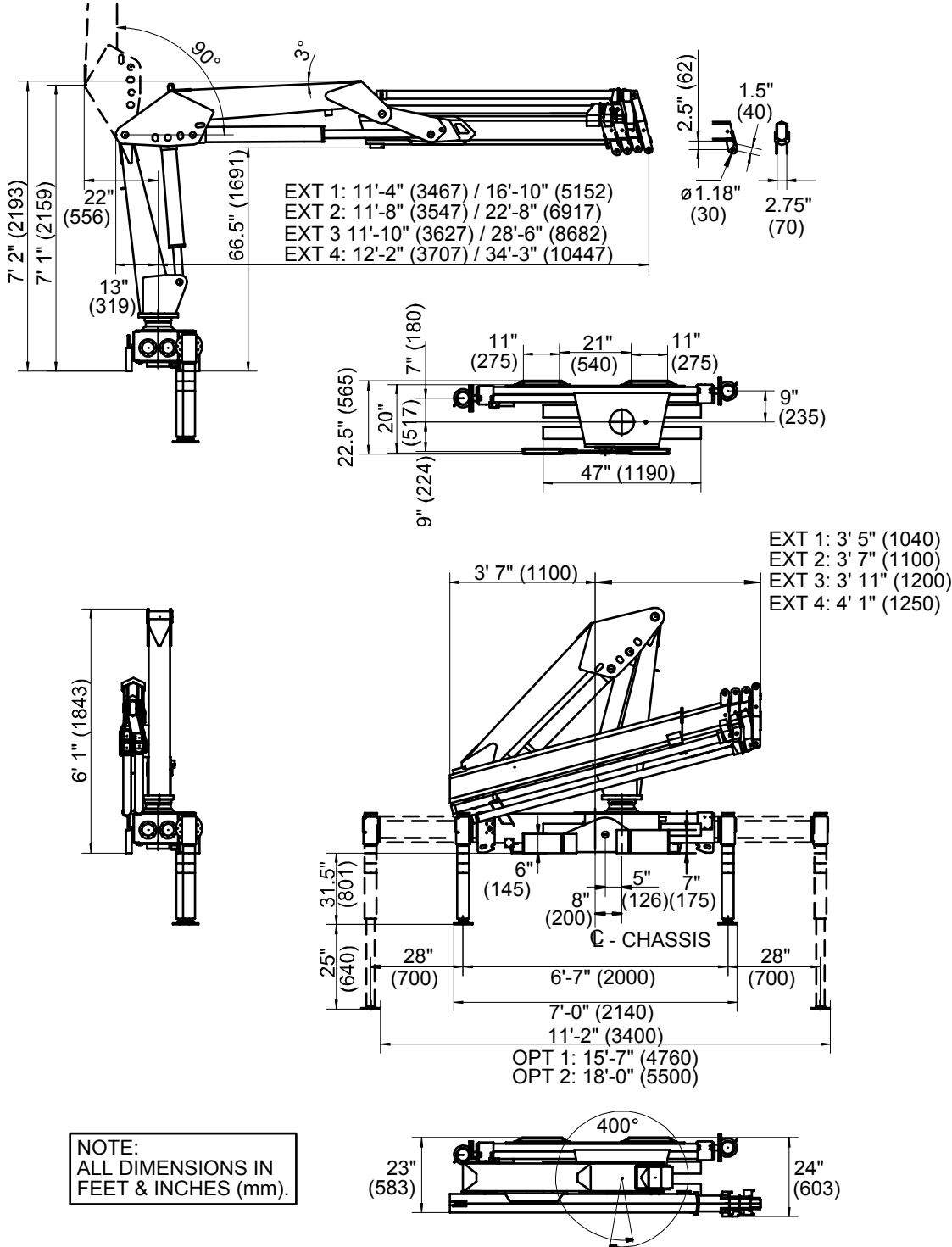

CHAPTER 2

Hydraulic Schematics

In This Chapter

Hydraulic Diagram - 6/39 Standard	12
Hydraulic Diagram - 6/39 with Extra Valves	13
Hydraulic Diagram - 6/39 with Winch	14
Hydraulic Diagram - 6/39 Hydrocontrol M50 - Radio.....	15
Hydraulic Diagram - 6/39 Danfoss PVG32.....	16

Hydraulic Diagram - 6/39 Standard

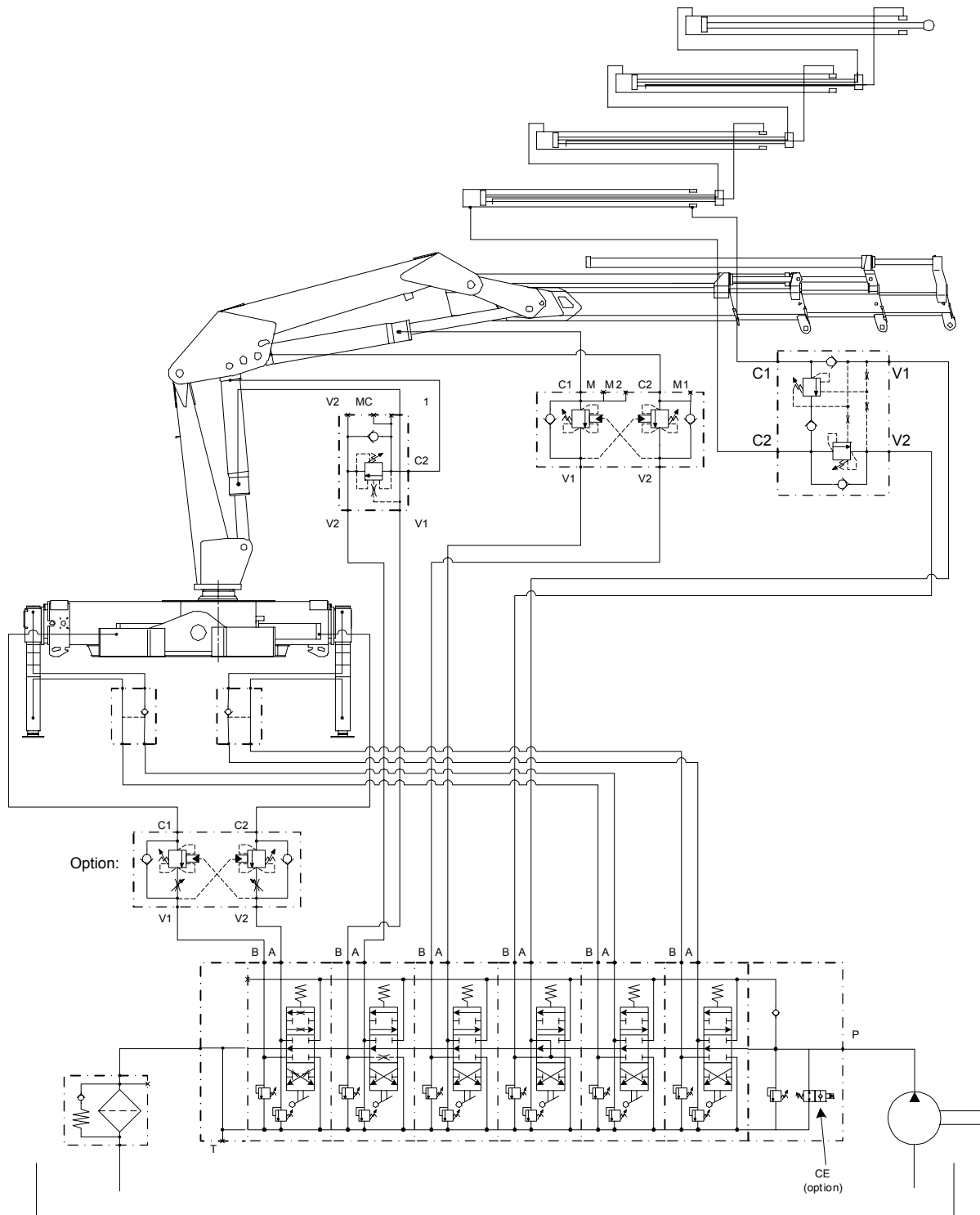

Hydraulic Diagram - 6/39 with Extra Valves

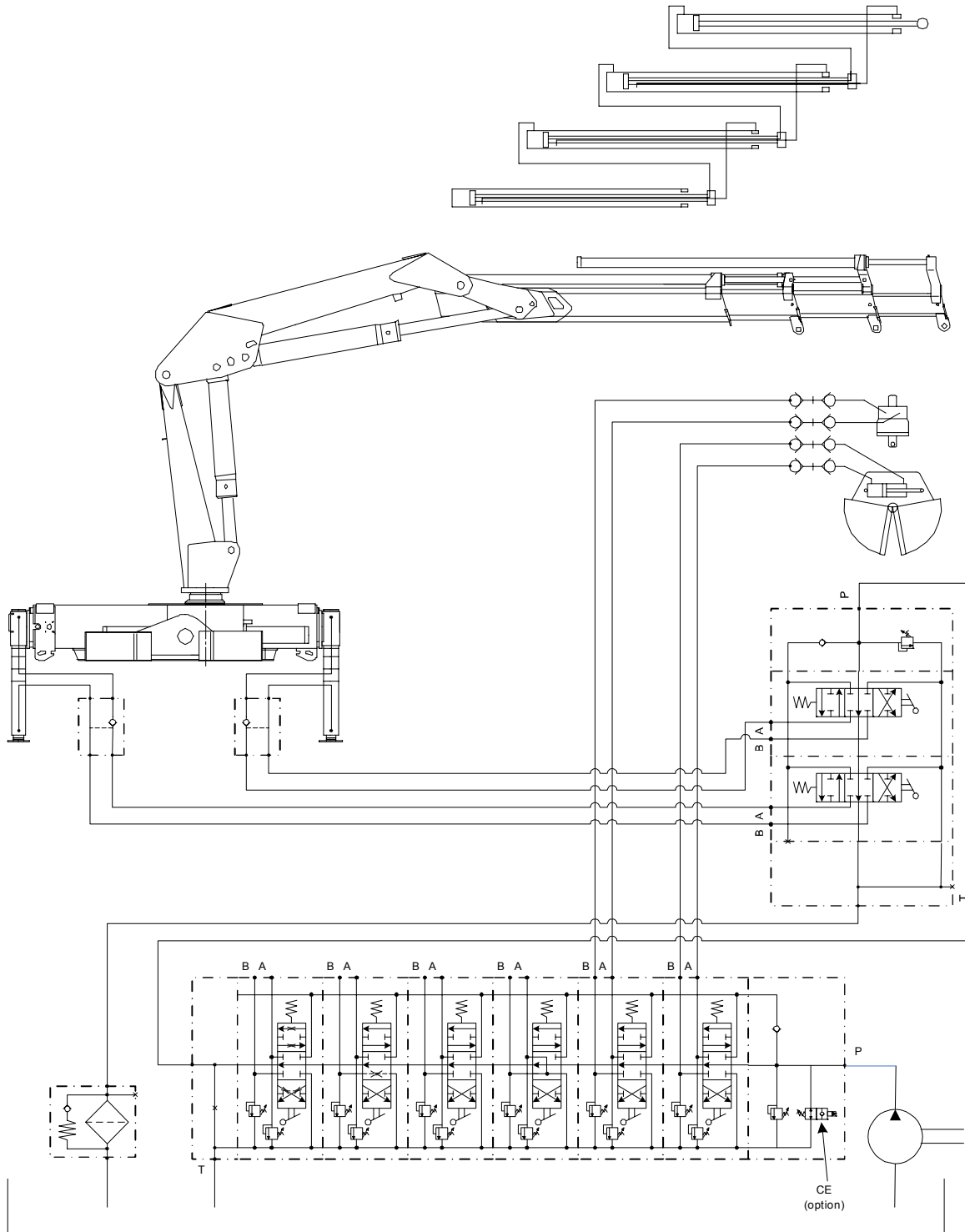

Hydraulic Diagram - 6/39 with Winch

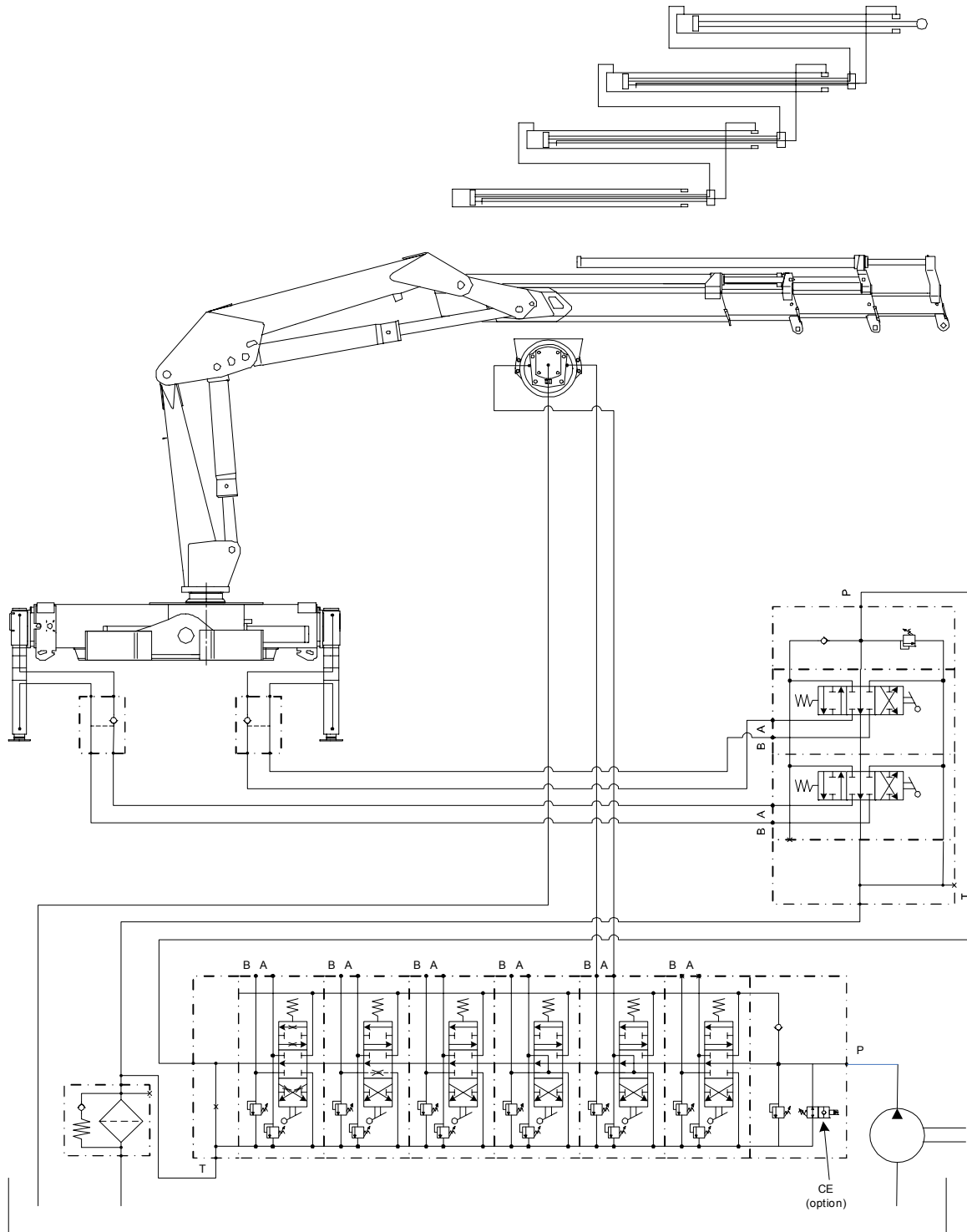

Hydraulic Diagram - 6/39 Hydrocontrol M50 - Radio

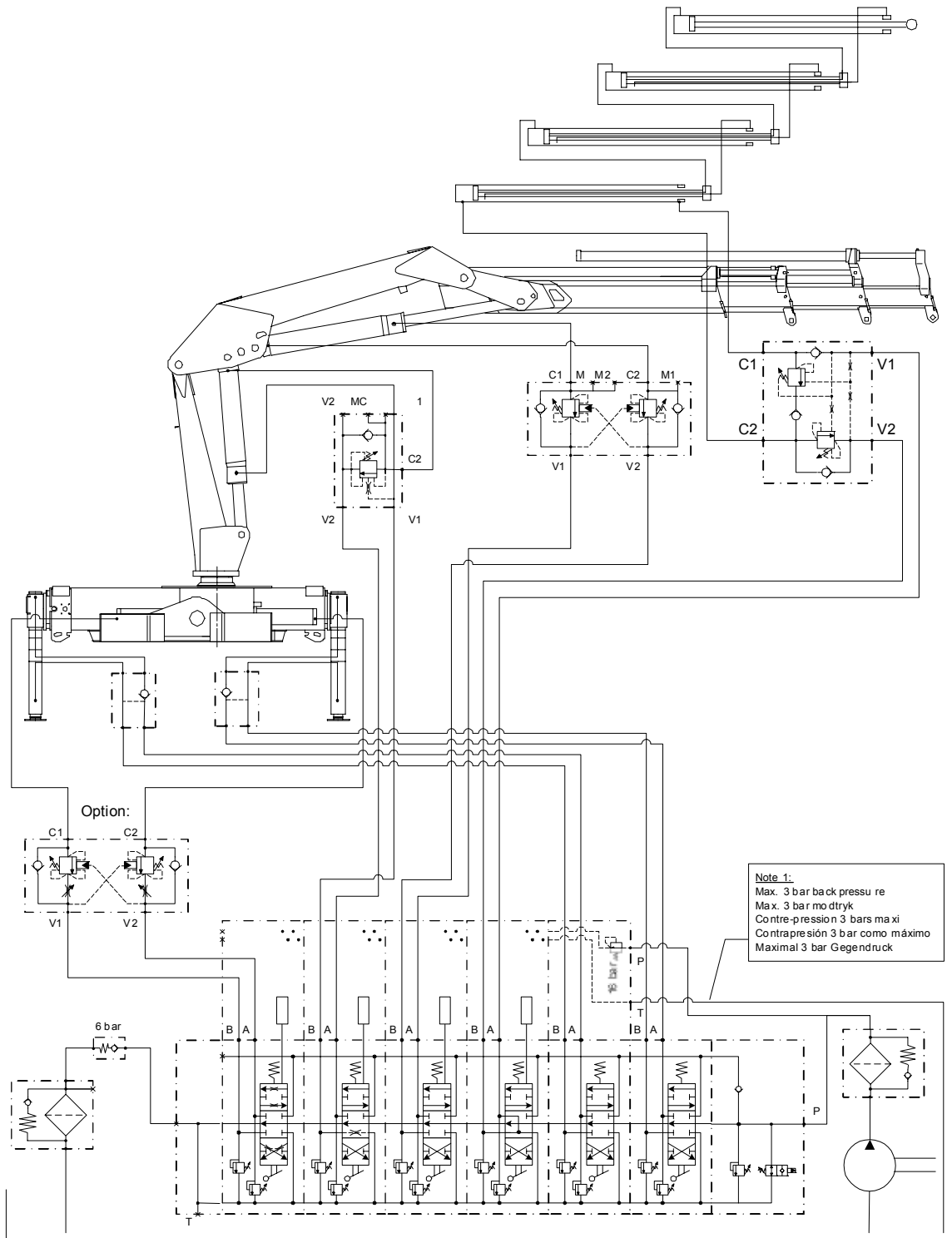

Hydraulic Diagram - 6/39 Danfoss PVG32

