

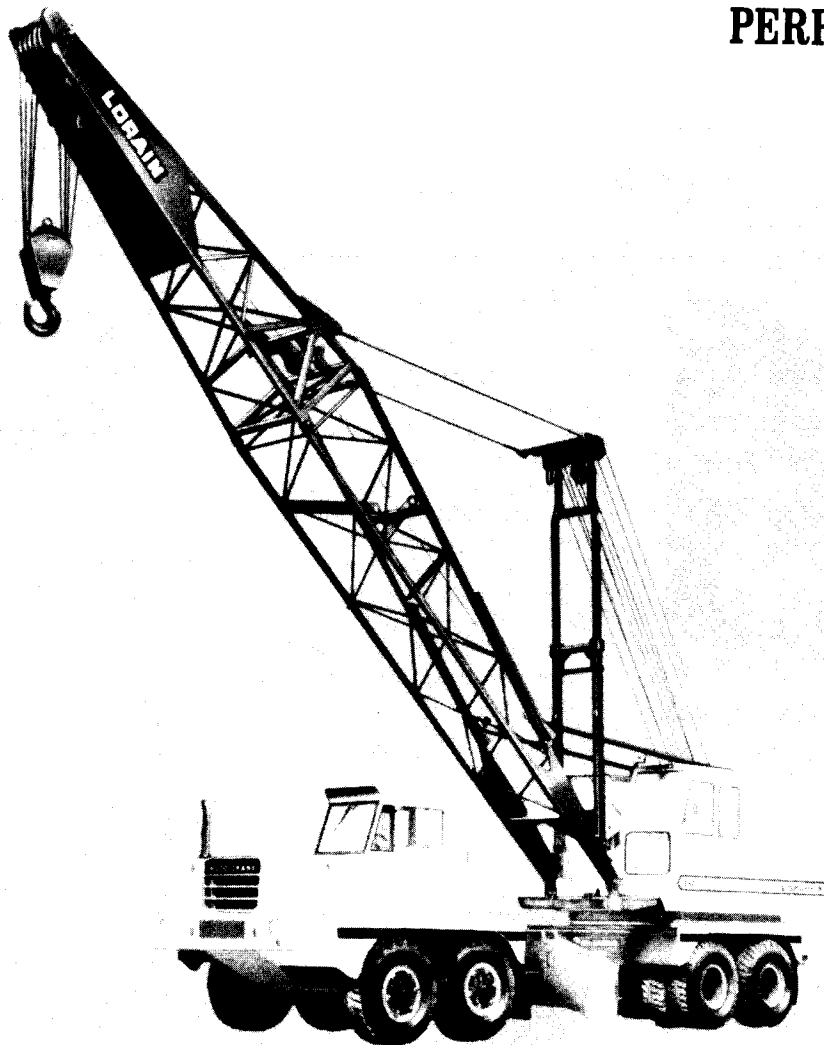

LORAIN

MC-550A
friction Moto-Crane

**STRONG ON
PERFORMANCE**



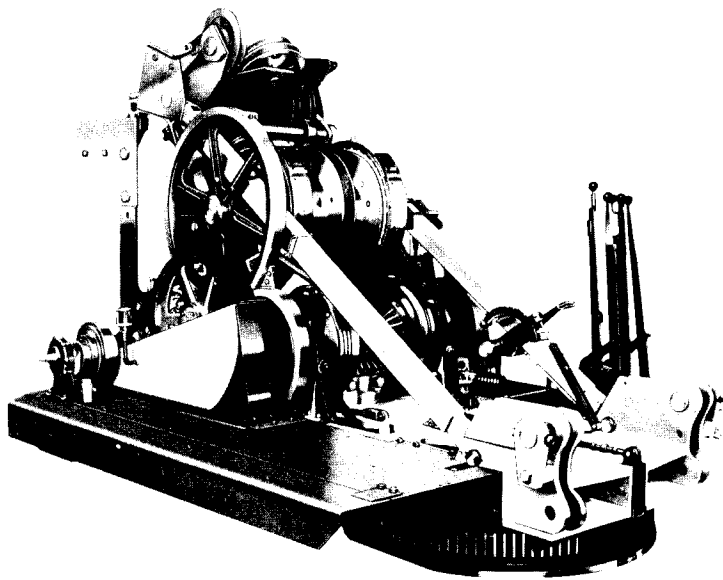

Specific Advantages

The Lorain MC-550A has been designed and engineered to give the following specific advantages.

- An ultra long boom
- Increased lifting capacities
- Increased cable capacity
- Less weight for maximum mobility
- Simple maintenance
- Designed dependability

The MC-550A turntable design is a study in simplicity. The components are arranged on the framework to provide direct power to the working end of the machine while utilizing its own machinery to serve as a counterweight. The A-frame design blends power, controls, and operating speeds to produce fast, smooth, operation. The torque converter serves as a cushion for the machinery and cables against shocks. The use of anti-friction bearings on the swing shaft and hoist shaft results in smooth, positive action. Power load lowering permits pin-point accuracy in placing the payload. These features combine to produce a machine capable of dependable, profitable performance.

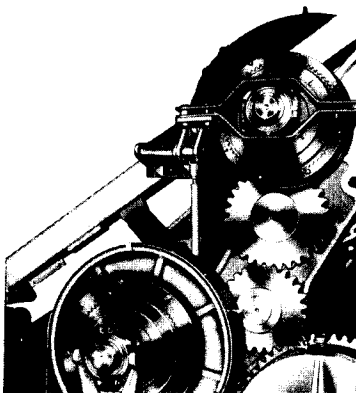

Dual Drum Boom Hoist

Each end of the boom hoist cable is attached to separate drum sections rotating in unison. This equalizes the pull on the boom tip and increases cable life. Drums are scored for smooth wrapping. The boom hoist brake is spring-loaded for additional safety. 10-part derricking is standard.

Power and Clutch Control of Independent Boom Action

The boom hoist and lowering mechanism is in constant engagement with the engine when in use. Both are power controlled, independently with a separate multi-plate disc-type clutch that drives the boom hoist shaft through a final enclosed planetary reduction gear (A). This provides precise control through an unlimited range of engine speeds. For maximum security, the ratchet and pawl (controlled from operator's position) are mounted directly on the end of the boom hoist shaft.

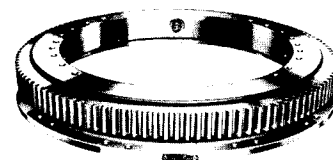
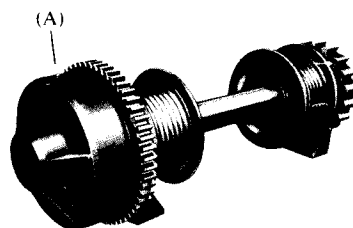

Shear-Ball®

The "Shear-Ball" acts as a giant, sealed ball bearing. One race is attached to the carrier, the other to the turntable with balls interlocking the two races. It allows the turntable to revolve smoothly. Load-Forces are distributed as compression loads over at least 40% of the balls — not on a few highly stressed rollers. The simplicity of design combined with the experience gained from building thousands of successful "Shear-Ball" connections enables LORAIN to offer an exclusive 10-year written warranty and offers you the following operating advantages:

- A) No Adjustments
- B) Rock Steady Swings
- C) Smooth, Fast Cycles
- D) Reduced Machine Height
- E) Minimum Maintenance

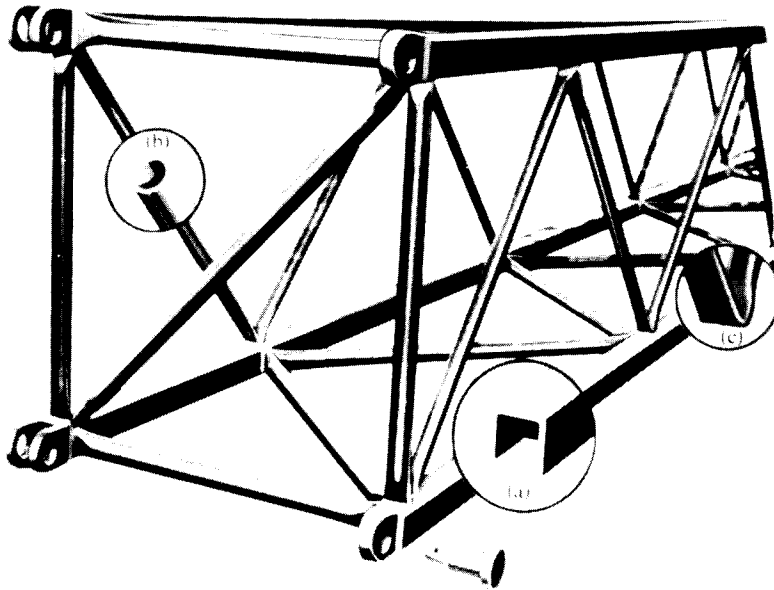

Square-Tubular-Chord Design

Designed for strength and durability, the square-tubular-chord boom is engineered for safety and performance. Four main chords of square-tubular cross section (a) are formed of high-strength alloy steel with a minimum yield strength of 130,000 psi. Hermetically sealed square-tube design, plus extra large cross section, provides maximum rigidity for long service life. Continuous, sealed round-tube lacing (b) is specially welded into a flat "maximum-contact" joint (c) at common points on the smooth inner faces of the main chord to provide high torsional resistance. Sections are pin-connected for fast rigging. 47° girth provides easy transportation, and superior strength.

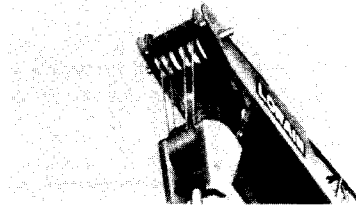

Offset Boom Tip

The open throat design allows high angle work at close radii . . . load and boom interference is minimized. Tapered pin connections for quick set-up. Maximum boom and jib combination 200' (60.9m.).



Long Tapered Boom Tip

Designed for best reach and capacity. The tapered boom concept is utilized for weight reduction .

Maximum boom and jib combination 210' (64.0m.).

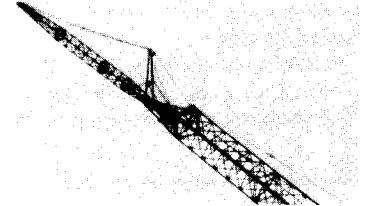

Fast Jib Set-Up

Jib is pendant-supported from base of boom tip. Eliminates lengthy cables and spreader bar. Two piece jib may be extended with taper pin connected center sections. Pre-sized backstay pendants are available to provide a wide range of jib offsets from 0 to 24 feet. Jib lengths available in 20', 30', 40', 50'.

Lorain Built Carrier

Lorain has designed and built its own carriers since 1939. Specifically mated to the superstructure, the carrier provides the rugged strength and mobility required for the most effective operation.

Excellent visibility is available from the cab and the comfortable contoured seat eases highway travel. A 13 speed Roadranger® transmission combined with double reduction planetary axles provides easy highway travel and good job-site mobility. Hydraulic steering assist eases operation in job-site conditions. Carrier frame rails are full box type construction of high strength alloy steel. Reinforcements and cross bracing provide a steady, working platform.

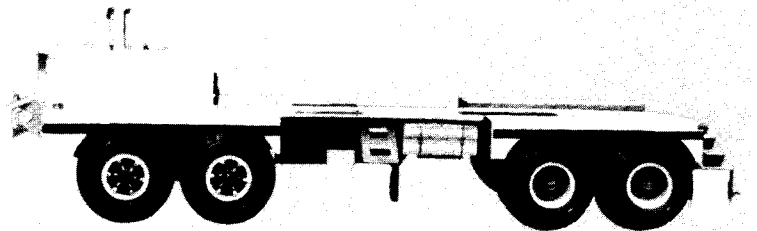

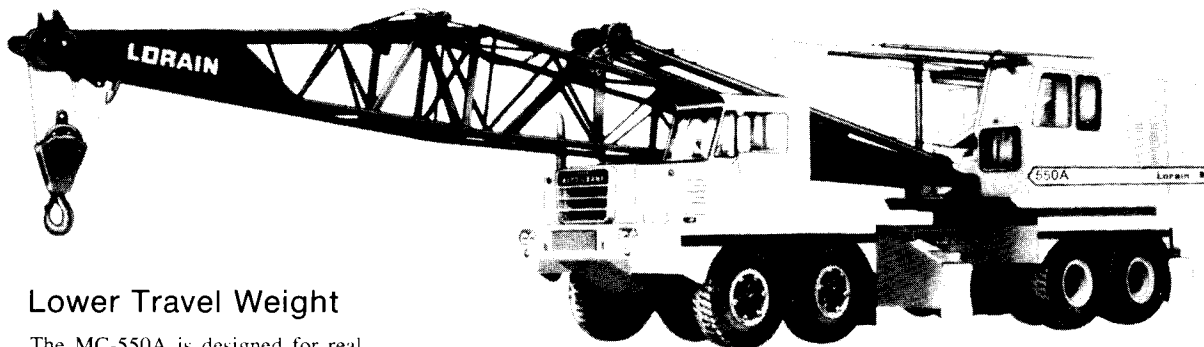

Lower Travel Weight

The MC-550A is designed for real mobility. It is a rugged 50 ton machine built to handle the big jobs, but it weighs less than most cranes in its class.

The telescopic mast type gantry permits travel with the basic boom carried in the travel position, without exceeding overall turntable height. The mast type gantry allows maximum boom and jib combination to be erected without outside assistance.

Removal of the outrigger boxes (both front and rear) and counterweight reduces the travel weight for easy mobility.



Easy Travel With Folding Boom

Booms can be folded easily and quickly for fast highway travel from job to job. In addition, a 50-ft. tip extension can be carried conveniently on a special

hanger. No helper truck needed. Job hopping like this results in a savings of time and money.

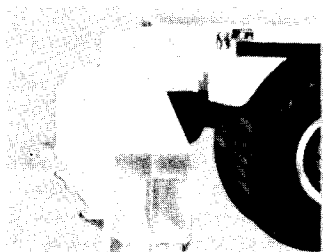

Power-Set® Outriggers

Hydraulically operated Power-Set outriggers provide a stable, dependable base for the MC-550A. Virtually any situation may be overcome due to the ability of the power-sets to operate individually. Positive wedge locks automatically secure outrigger beams, independent of the hydraulic system. The heavier the load—the tighter they become. Floats are self-adjusting according to terrain, and retract flat against the carrier.

Power-Set outriggers contain about half the number of hydraulic components as other outrigger systems for reduced maintenance.

Boxes are pin connected for easy removal and fast weight reduction for travel. Hydraulic lines are removed via quick disconnects.

Power-Set outriggers . . . simple, safe, and secure.

WE RESERVE THE RIGHT TO AMEND THESE SPECIFICATIONS AT ANY TIME WITHOUT NOTICE. THE ONLY WARRANTY APPLICABLE IS OUR STANDARD WRITTEN WARRANTY. WE MAKE NO OTHER WARRANTY, EXPRESSED OR IMPLIED.



Koehring
International Marketing (KIMCO)
Milwaukee, WI 53201

LORAIN MC-550A

MOTO-CRANE®

specifications

dimensions

work ranges

lift capacities

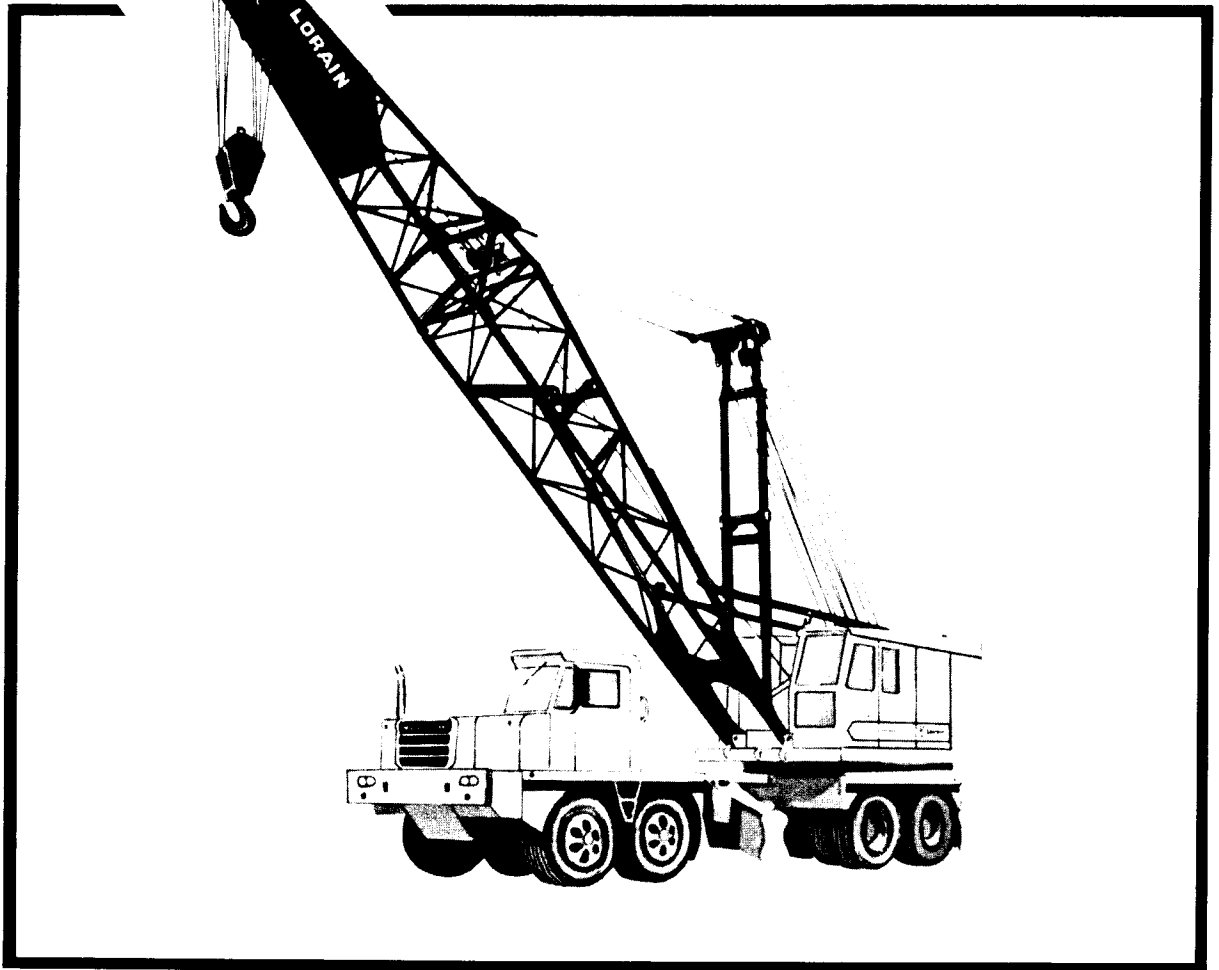

FEATURES:

- Preferred Square Tubular Chord Boom
- Choice of Two Peaks — Offset, Tapered
- 210'—Boom and Jib Combination
- Dual Drum Boom Hoist
- Tower Available
- Enclosed All Gear Drive
- Mechanical Controls
- 10-Year Warranted "Shear-Ball" Turntable Connection
- Performance Matched Lorain-Built Carrier
- Easy Weight Reduction

MC-550 A MOTO-CRANE®

SPECIFICATIONS

TURNTABLE SPECIFICATIONS

Power	
Diesel	GM 4-71N, 6 Cyl.
Bore and Stroke	4¼ in. x 5 in.
Displacement	284 cu. in.
Horsepower	115 H.P.
Power Take-Off	Torque Converter
Fuel Tank	50 gals.
Operating Characteristics	
Line Pulls and Line Speeds:	
Main Hoist (15" P.D.)	17,250 lbs. @ 170 FPM
Secondary Hoist (15" P.D.)	17,250 lbs. @ 170 FPM
Swing Speed	4.0 R.P.M.
Controls	Manual Mechanical
Other Equipment	
Boom Hoist	Planetary Drive, Dual Drum
Gantry	Telescopic Mast Type, Air Operated
Counterweight, Removable	24,900 lbs.
Turntable Connection	External Gear Shear-Ball®

MOTO-CRANE SPECIFICATIONS

Power	
Diesel	GM 6-71N, 6 cyl.
Bore and Stroke	4¼ in. x 5 in.
Displacement	425.6 cu. in.
Horsepower	246 H.P.
Power Take-Off	Plate Clutch
Fuel Tank	75 gals.
Transmission	
Roadranger	13 Speeds Forward 2 Speeds Reverse
Low-low	1.6 M.P.H.
High-high	47 M.P.H.
Outriggers	Power Set® Hydraulically Operated, Complete With Floats
Rear Bogie	
Axles (Planetary)	Double Reduction Gear Drive
First reduction thru hypoid gears; final reduction thru planetary wheel hubs; high-traction differentials. Interaxle differential with lockout.	
Mounting	Two Axles in tandem, with "through-drive," mounted on equalizer beams.

Front Tandem	Two non-driving axles mounted on equalizer beams.
Steering	Centralized, Hydraulic Power Assist
Turning Radius (to Front Corner of Vehicle)	54 ft. 2 in.
Brakes (Spring Set for Emergency and Parking)	
Rear	4 Brakes; 17¼ in. dia. x 5½ in. wide
Front	4 Brakes; 17¼ in. dia. x 4 in. wide
Tires (Tube)	14:00 x 20, 18 P.R.

BOOM EQUIPMENT

Crane Boom	
Design	Square-Tubular-Chord
Type of Connection	Pin-Connected
Basic Length—Offset Peak Boom	40 ft.; 25-ft. base, 15-ft. top
Long Tapered Peak Boom	60 ft.; 25-ft. base, 35-ft. top
Number of Hoist Line Sheaves at Boom Head on Anti-Friction Bearings	
Offset Boom	4
Long Tapered Boom	2
	(Additional Sheaves Available)
Jib	
Two-Piece* Pin-Connected Type	20 ft.; 10-ft. base, 10-ft. peak
	*Extendible with 10-ft. Center Sections to 50 ft.
Lifting Crane Component	
Laggings	Two, 15 in. P.D.
Floating Harness	10 Parts of Line
Boom Lowering	by Power, Clutch Controlled
Boom Stops	Telescopic Type
Swing Brake	Standard
Power Load Lowering (right hand hoist drum)	Available
Third Drum	Available

APPROXIMATE SHIPPING WEIGHTS

Standard Equipped Machines with Basic Boom	
Lifting Crane	102,705 lbs.*
*Total weight of unit may be reduced 24,900 lbs. by taking off removable counterweight for road travel. Additional reductions may be made by removal of outrigger boxes and beams.	

We reserve the right to amend these specifications at any time without notice. The only warranty applicable is our standard written warranty. **We Make No Other Warranty, Expressed Or Implied.**

GENERAL DIMENSIONS:

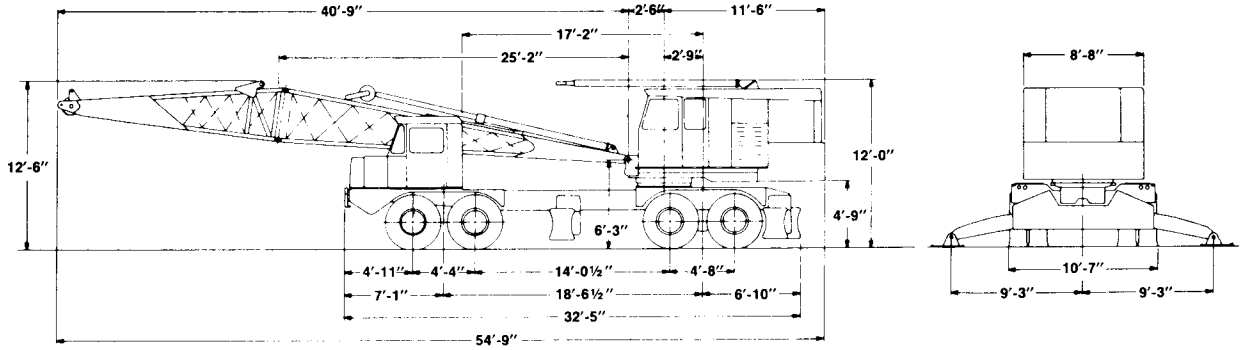

REVIEW THE FOLLOWING NOTES BEFORE USING THIS SPECIFICATION TO DETERMINE ALLOWABLE BOOM LENGTHS. RADIUS AND WEIGHT OF LOAD IN POUNDS PERTAIN TO THIS MACHINE AS ORIGINALLY MANUFACTURED AND EQUIPPED.

NOTES:

1. The rated loads as determined by boom length, radius and weight of load apply to this machine as originally manufactured and equipped and as mounted on a Lorain manufactured MC-550A, 8 x 4 carrier. **THEY ARE MAXIMUM** lifting capacities and comply with standards of the Power Crane & Shovel Association as issued by the U.S. Department of Commerce Commercial Standard CS90-58 and the SAE Crane Load Stability Test Code J765.
- 1a. **DO NOT** tip the machine to determine the allowable loads. Rated loads should not be exceeded. Rated loads are based on 85% of stability except where set in bold face type they are based on machinery and structural strength.
- 1b. All rated loads are based on the machine being on a firm, level and uniform supporting surface. Before lifting at, or near, rated loads, the machine should be leveled with \pm commercial level in two directions. **FOR SAFE WORKING LOADS THE USER** is expected to make due allowances for his particular job conditions such as: soft or uneven ground, out of level conditions, side loads, pendulum action, jerking or sudden stopping of loads, hazardous conditions,

experience of personnel, etc. Side pull on boom or jib is extremely dangerous. **CAUTION:** The operator and other personnel should fully read and acquaint themselves with Operators Manual furnished by the manufacturer **BEFORE** operating this machine, and Rules for Safe Operation of equipment should be adhered to at all times. Operators and supervisors should also acquaint themselves with Standard Safety Codes for Cranes, Derricks and Hoists, ASA-B 30.2-1943 (R-1952).

- 1c. Do not exceed the "over-the-rear" capacities when lifting over a corner.
- 1d. Use blocking under front tires or front part of carrier if boom and/or load is to be moved forward of front outriggers.
- 1e. All lifting must be done with mast erected. When working conditions will not permit erected mast, consult Lorain for proper capacity chart.
- 1f. The total weight of bucket plus load must not exceed 80% of the rated "without outriggers" lifting capacities up to a maximum of 8000 lbs. for dragline service and 9800 lbs. for clamshell service.

CRANE WORKING AREAS:

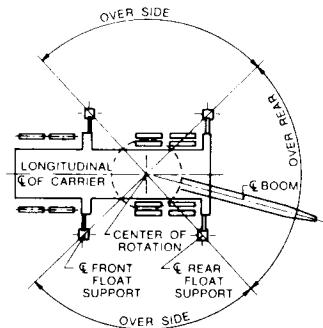

Carrier With Outriggers

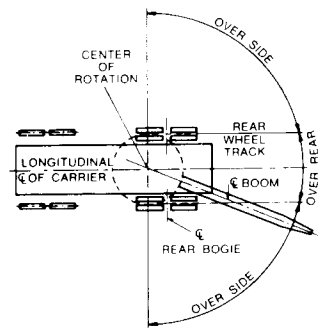

Carrier Without Outriggers

MC-550 A

Load Ratings With

RADIUS DIAGRAM:

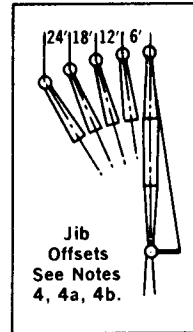
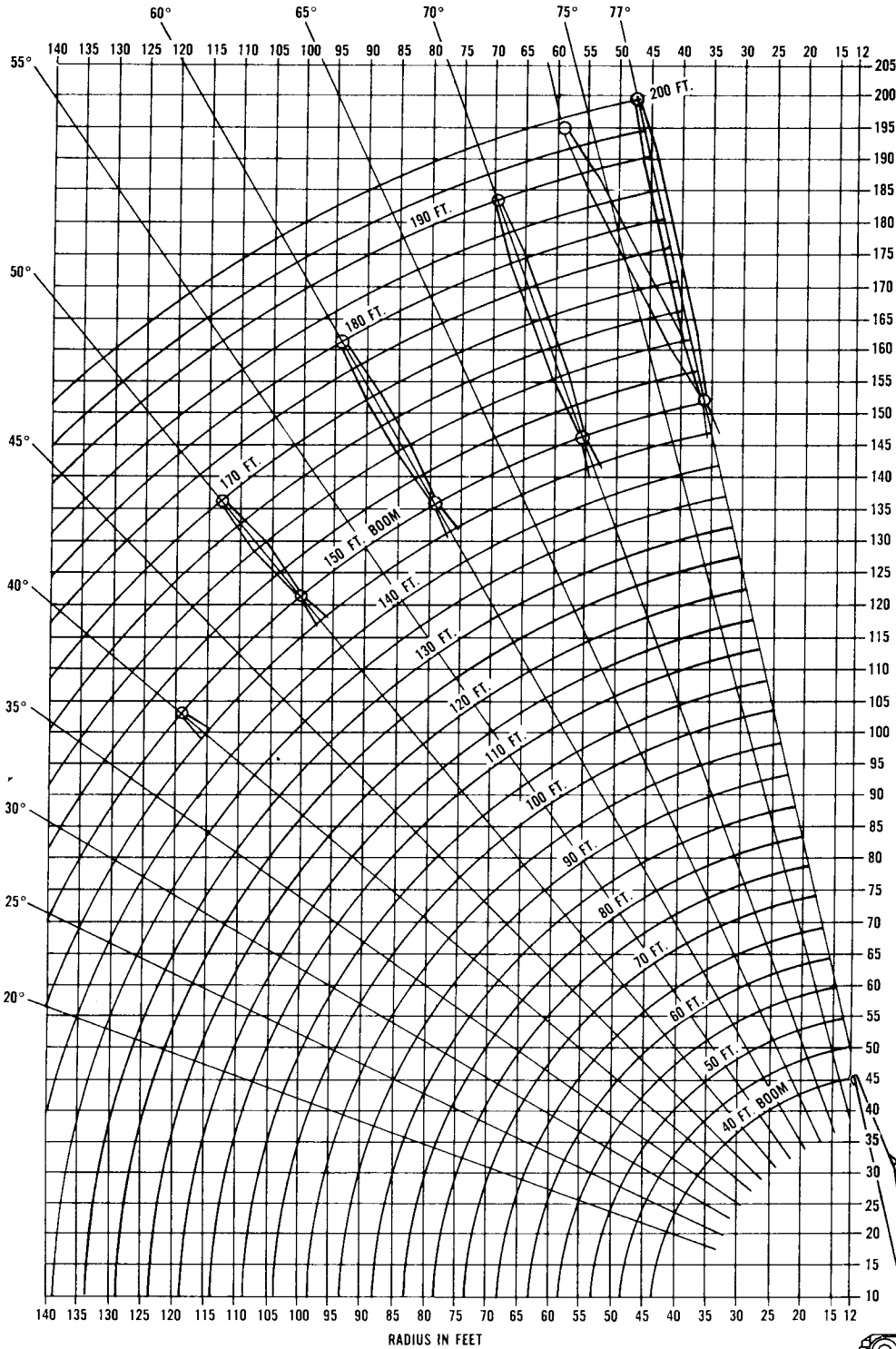

VERTICAL HEIGHT IN FEET

**D15 BOOM
WORKING
RANGES
MC-550_A
8x4**

This data apply only to machines with serial numbers above 34507

P.C.S.A. CLASS 12-307

**OFFSET BOOM
PEAK**

Offset Boom Peak

CAPACITY CHART:

Maximum Rated Load In Pounds

Boom Length	Radius	With Outriggers		Without Outriggers		Boom Length	Radius	Boom Angle	With Outriggers		Without Outriggers	
		Over Rear	Over Side	Over Rear	Over Side				Over Rear	Over Side	Over Rear	Over Side
40 Ft.	12 76.4	10000	10000	7000	6930	130 Ft.	30 78.1	40100	40100	20800	18600	
	15 72.5	84200	84200	52300	49900		35 75.9	33900	33900	17000	15000	
	20 64.9	67500	67500	36500	33700		40 73.6	29200	29200	14200	12400	
	25 58.2	50600	50600	27800	25100		45 71.8	25300	25100	12100	10400	
	30 48.4	42000	42000	22200	19900		50 69.3	22100	21600	10400	8900	
	35 40.0	35800	35800	18400	16300		60 64.7	17500	16600	8000	6600	
40 21.0	31100	30800	15700	13700	70 59.8	14300	13300	6200	5100			
50 Ft.	12 78.9	100000	100000	69900	69200	80 55.7	11900	10900	4900	3900		
	15 75.9	83900	83900	52200	49800	90 49.6	10000	9100	3900	3000		
	20 70.0	67300	67300	36300	33500	100 43.1	8500	7600	3200	2300		
	25 64.3	50400	50400	27600	25000	110 35.5	7300	6500	2500	1800		
	30 59.0	41800	41800	22100	19700	120 26.2	6300	5600	2000	1500		
	35 51.4	35600	35600	18300	16200	130 11.9	5500	4800	1500	1100		
40 43.1	30900	30700	15500	13600	140 Ft.	30 78.8	35000	35000	20700	18400		
45 33.0	27200	26100	13400	11600		35 76.7	32900	32900	16900	14800		
50 18.7	24200	22600	11700	10100		40 75.1	28500	28500	14100	12200		
60 Ft.	15 78.2	83700	83700	52000		49600	45 72.9	24600	24600	12000	10300	
	20 73.4	67100	67100	36200		33400	50 71.1	21500	21500	10300	8700	
	25 68.8	50200	50200	27500		24900	60 66.9	17000	16000	7800	6500	
	30 63.8	41600	41600	21900	19600	70 62.0	13800	13100	6100	4900		
	35 59.0	35300	35300	18100	16000	80 59.0	11400	10700	4800	3800		
	40 53.2	30600	30600	15300	13400	90 53.2	9600	8900	3800	2900		
45 46.7	27000	25900	13200	11500	100 47.7	8100	7500	3000	2200			
50 39.1	24000	22400	11500	9900	110 41.4	6900	6400	2400	1600			
60 17.7	19200	17500	9100	7700	120 34.2	5900	5400	1800	1300			
70 Ft.	15 79.4	83400	83400	51900	49500	130 25.2	5100	4700	1500	1100		
	20 75.9	66900	66900	36000	33300	140 11.5	4400	4000	1300	900		
	25 72.0	50000	50000	27300	24700	150 Ft.	30 79.2	31000	31000	20500	18300	
	30 67.9	41400	41400	21800	19400		35 77.9	29900	29900	16700	14700	
	35 63.5	35100	35100	18000	15900		40 75.9	27500	27500	13900	12100	
	40 59.0	30400	30400	15200	13300		45 74.4	23900	23900	11800	10100	
45 55.0	26800	25800	13100	11300	50 72.3		20900	20900	10100	8600		
50 49.1	23800	22300	11400	9800	60 68.4		16400	16400	7700	6300		
60 36.1	19000	17400	8900	7600	70 64.3	13300	13000	5900	4800			
70 16.3	15500	14100	7200	6000	80 59.9	11000	10600	4600	3600			
80 Ft.	20 77.8	66700	66700	35900	33100	90 56.5	9200	8800	3600	2700		
	25 74.5	49700	49700	27100	24600	100 51.4	7700	7400	2800	2000		
	30 70.9	41100	41100	21600	19300	110 46.0	6600	6200	2200	1600		
	35 67.1	34900	34900	17800	15700	120 39.9	5600	5300	1700	1200		
	40 63.3	30200	30200	15000	13100	130 33.0	4800	4500	1400	1000		
	45 59.0	26600	25700	12900	11200	140 24.3	4100	3900	1200	800		
50 55.9	23600	22200	11200	9600	150 11.1	3500	3300	1000	700			
60 45.8	18900	17200	8800	7400	CAPACITIES BELOW INCLUDE JIB (See Note 4a)							
70 33.7	15400	13900	7000	5800	160 Ft.	35 78.4	26000	26000	16600	14500		
80 15.3	12800	11500	5700	4700		40 76.6	24900	24900	13800	11900		
90 Ft.	20 78.8	66500	66500	35700		33000	45 75.2	22900	22900	11700	10000	
	25 75.9	49500	49500	27000		24400	50 73.2	20100	20100	10000	8400	
	30 72.8	40900	40900	21500		19100	60 69.6	15700	15700	7500	6200	
	35 69.5	34700	34700	17700		15600	80 61.9	10400	10400	4500	3500	
	40 66.0	30000	30000	14900	13000	100 54.9	7200	7200	2700	1900		
	45 62.5	26400	25600	12700	11000	120 44.5	5100	5100	1500	1100		
50 59.0	23400	22100	11100	9500	140 31.9	3700	3700	1000	700			
60 52.2	18800	17100	8600	7200	160 10.7	2600	2600	800	600			
70 43.1	15200	13800	6900	5700	170 Ft.	35 78.9	24400	24400	16400	14400		
80 31.7	12700	11400	5600	4500		40 77.7	22400	22400	13600	11800		
90 14.4	10700	9600	4600	3600		45 75.9	20500	20500	11500	9800		
100 Ft.	20 79.5	66300	66300	35600		32800	50 74.6	19000	19000	9700	8200	
	25 76.9	49300	49300	26800		24300	60 71.2	14600	14600	7300	5900	
	30 74.8	40700	40700	21300		19000	80 64.0	9900	9900	4200	3200	
	35 71.9	34500	34500	17500	15400	100 57.1	6800	6800	2400	1600		
	40 68.8	29800	29800	14700	12800	120 48.1	4800	4800	1400	1000		
	45 65.6	26200	25500	12600	10900	140 37.4	3300	3300	1000	700		
50 62.4	23200	22000	10900	9300	160 22.8	2300	2300	800	600			
60 57.0	18600	17000	8400	7100	180 Ft.	40 78.2	18000	18000	13500	11600		
70 49.4	15100	13700	6700	5500		45 76.5	16800	16800	11300	9700		
80 40.7	10600	9500	4400	3500		50 75.3	15800	15800	9700	8100		
90 19.6	9100	8100	3600	2800		60 72.1	12000	12000	7200	5900		
110 Ft.	25 78.4	49100	49100	26700		24100	80 65.3	9500	9500	4200	3100	
	30 75.9	40500	40500	21200		18900	100 59.0	6400	6400	2400	1600	
	35 73.3	34300	34300	17300	15300	120 51.2	4400	4400	1400	1000		
	40 71.1	29600	29600	14600	12700	140 41.8	3000	3000	1000	700		
	45 68.2	25900	25400	12400	10700	160 30.0	1900	1900	700	500		
	50 65.2	23000	21800	10800	9200	190 Ft.	40 78.7	13000	13000	13000	11500	
60 59.7	18500	16900	8300	6900	45 77.0		13000	13000	11200	9500		
70 54.6	14900	13500	6500	5400	50 75.9		13000	13000	9500	8000		
80 47.0	12400	11100	5300	4200	60 72.9		8000	8000	7000	5700		
90 38.8	10500	9300	4300	3300	80 67.1		8000	8000	4000	3000		
100 28.5	8900	7900	3500	2600	100 60.0		6000	6000	2200	1600		
110 13.0	7700	6800	2800	2100	120 54.3	4000	4000	1400	1000			
120 Ft.	25 79.0	48900	48900	26500	24000	140 45.4	2700	2700	700	500		
	30 76.8	40300	40300	21000	18700	160 35.3	1600	1600	400	300		
	35 75.0	34100	34100	17200	15100	200 Ft.	45 78.1	10000	10000	10000	9400	
	40 72.5	29400	29400	14400	12500		50 76.4	10000	10000	9300	7800	
	45 69.8	25700	25300	12300	10600		60 73.6	6000	6000	6000	5600	
	50 67.7	22800	21700	10600	9000		80 68.1	6000	6000	3800	2800	
60 62.2	18100	16700	8100	6800	100 61.8		5100	5100	2100	1500		
70 58.2	14800	13400	6400	5200	120 56.3		3500	3500	1200	800		
80 51.7	12300	11000	5100	4100	140 48.4	2300	2300	800	600			
90 44.9	10300	9200	4100	3200	CAPACITIES BELOW INCLUDE JIB (See Note 4a)							
100 37.0	8800	7800	3300	2500	160 Ft.	35 78.4	26000	26000	16600	14500		
110 27.3	7600	6700	2700	1900		40 76.6	24900	24900	13800	11900		
120 12.4	6600	5700	2100	1600		45 75.2	22900	22900	11700	10000		
90 Ft.	20 78.8	66500	66500	35700		33000	50 73.2	20100	20100	10000	8400	
	25 75.9	49500	49500	27000		24400	60 69.6	15700	15700	7500	6200	
	30 72.8	40900	40900	21500		19100	80 61.9	10400	10400	4500	3500	
	35 69.5	34700	34700	17700	15600	100 54.9	7200	7200	2700	1900		
	40 66.0	30000	30000	14900	13000	120 44.5	5100	5100	1500	1100		
	45 62.5	26400	25600	12700	11000	140 31.9	3700	3700	1000	700		
50 59.0	23400	22100	11100	9500	160 10.7	2600	2600	800	600			
60 52.2	18800	17100	8600	7200	170 Ft.	35 78.9	24400	24400	16400	14400		
70 43.1												

MC-550 A

Load Ratings With

RADIUS DIAGRAM:

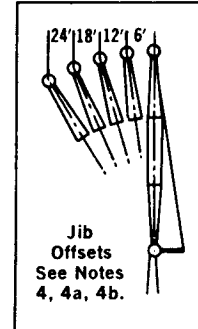
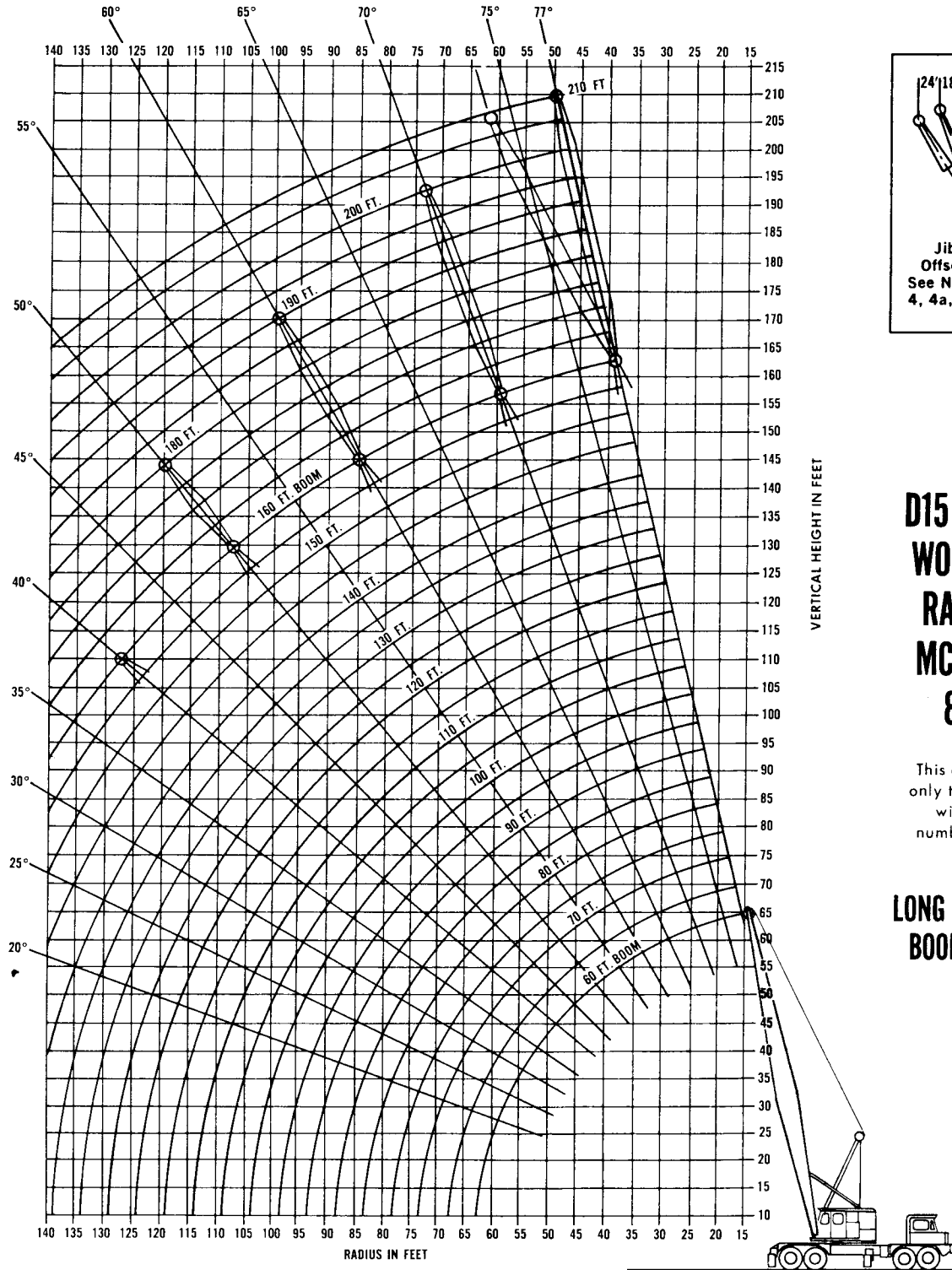

**D15 BOOM
WORKING
RANGES
MC-550 A
8x4**

This data apply only to machines with serial numbers above 34507

**LONG TAPERED
BOOM PEAK**

Long Tapered Boom Peak

CAPACITY CHART:

Maximum Rated Load In Pounds

Boom Length	Radius	Boom Angle	With Outriggers		Without Outriggers	
			Over Rear	Over Side	Over Rear	Over Side
60 Ft.	15	78.2	84300	83400	52400	49900
	20	73.4	67600	67600	36500	33700
	25	68.8	50700	50700	27800	25200
	30	63.8	42100	42100	22300	19900
	35	59.0	35800	35800	18500	16400
	40	53.2	31100	30900	15700	13800
	45	46.7	27500	26200	13600	11800
	50	39.1	24500	22700	11900	10300
	55	31.7	19500	17800	9400	8100
	60	17.7				
70 Ft.	15	79.4	84000	84000	52200	49800
	20	75.9	67400	67400	36400	33600
	25	72.0	50400	50400	27600	25000
	30	67.9	41800	41800	22100	19800
	35	63.5	35600	35600	18300	16200
	40	59.0	30900	30700	15500	13600
	45	55.0	27200	26100	13400	11700
	50	49.1	24300	22600	11700	10100
	60	36.1	19300	17700	9300	7900
	70	16.3	15800	14400	7500	6300
80 Ft.	20	77.8	67200	67200	36200	33400
	25	74.5	50200	50200	27500	24900
	30	70.9	41600	41600	21900	19600
	35	67.1	35300	35300	18100	16000
	40	63.3	30700	30600	15300	13400
	45	59.6	27000	26600	13200	11500
	50	55.9	24000	22400	11500	10000
	60	45.8	19200	17500	9100	7700
	70	33.7	15600	14200	7300	6100
	80	15.3	13100	11800	6000	5000
90 Ft.	20	78.8	67000	67000	36000	33200
	25	75.9	49900	49900	27300	24700
	30	72.8	41300	41300	21800	19400
	35	69.5	35100	35100	17900	15800
	40	66.0	30400	30400	15200	13300
	45	62.5	26700	25800	13000	11300
	50	59.0	23800	22300	11400	9800
	60	52.2	19000	17400	8900	7500
	70	43.1	15500	14000	7100	6000
	80	31.7	12900	11700	5900	4800
90	14.4	11000	9900	4900	3900	
100 Ft.	20	79.5	66800	66800	35800	33100
	25	76.9	49700	49700	27100	24500
	30	74.8	41100	41100	21600	19300
	35	71.9	34900	34900	17800	15700
	40	68.8	30200	30200	15000	13100
	45	65.6	26500	25700	12900	11100
	50	62.4	23500	22200	11200	9600
	60	57.0	18900	17200	8700	7400
	70	49.4	15300	13900	7000	5800
	80	40.7	12800	11500	5700	4600
90	30.0	10800	9700	4700	3800	
100	13.6	9300	8300	3900	3100	
110 Ft.	25	78.4	49400	49400	26900	24400
	30	75.9	40800	40800	21400	19100
	35	73.3	34600	34600	17600	15500
	40	71.1	29900	29900	14800	12900
	45	68.2	26300	25600	12700	11000
	50	65.2	23300	22000	11000	9400
	60	58.7	18700	17100	8500	7200
	70	50.6	15200	13700	6800	5600
	80	47.0	12600	11300	5500	4500
	90	38.8	10700	9500	4500	3600
100	28.5	9200	8100	3700	2900	
110	13.0	8000	7000	3100	2300	
120 Ft.	25	79.0	49200	49200	26700	24200
	30	76.8	40600	40600	21200	18900
	35	75.0	34400	34400	17400	15300
	40	72.5	29700	29700	14600	12700
	45	69.8	26000	25400	12500	10800
	50	67.7	23100	21900	10800	9200
	60	62.2	18500	16900	8300	7000
	70	58.2	15000	13600	6600	5400
	80	51.7	12400	11200	5300	4300
	90	44.9	10500	9400	4300	3400
100	37.0	9000	8000	3500	2700	
110	27.3	7800	6900	2900	2100	
120	12.4	6800	5900	2400	1600	
130 Ft.	30	78.1	40300	40300	21000	18700
	35	75.9	34100	34100	17200	15200
	40	73.6	29400	29400	14400	12600
	45	71.8	25800	25300	12300	10600
	50	69.3	22600	21800	10600	9100
	60	64.7	18000	16800	8200	6800
	70	59.8	14700	13400	6400	5300
	80	55.7	12200	11000	5100	4100
	90	49.6	10300	9200	4100	3200
	100	43.1	8800	7800	3300	2500
110	35.5	7600	6700	2700	1900	
120	26.2	6600	5800	2200	1500	
130	11.9	5800	5000	1800	1200	

Boom Length	Radius	Boom Angle	With Outriggers		Without Outriggers	
			Over Rear	Over Side	Over Rear	Over Side
140 Ft.	30	78.7	37000	37000	20800	18600
	35	76.7	33100	33100	17000	15000
	40	75.1	29100	29100	14300	12400
	45	72.9	25100	25100	12100	10400
	50	71.1	22000	21600	10400	8900
	60	66.9	17400	16600	8000	6600
	70	62.0	14200	13300	6200	5100
	80	59.0	11800	10900	4900	3900
	90	53.2	9900	9100	4000	3000
	100	47.7	8500	7700	3200	2300
150 Ft.	30	79.2	33300	33300	20700	18400
	35	77.9	30400	30400	16900	14800
	40	75.9	28000	28000	14100	12200
	45	74.4	24400	24400	11900	10300
	50	72.3	21400	21400	10300	8700
	60	68.4	16900	16500	7800	6500
160 Ft.	30	80.1	30000	30000	20500	18200
	35	78.4	27800	27800	16700	14600
	40	76.6	25400	25400	13900	12000
	45	75.2	23400	23400	11800	10100
	50	73.2	20800	20800	10100	8500
	60	69.6	16300	16300	7600	6300
	80	61.9	10800	10600	4600	3600
	100	54.9	7600	7300	2800	2000
	120	44.5	5500	5300	1600	1100
	140	31.9	4000	3800		
160	10.7	2900	2800			
CAPACITIES BELOW INCLUDE JIB (See Note 4a)						
170 Ft.	35	78.9	25100	25100	16500	14500
	40	77.7	23100	23100	13700	11900
	45	75.9	21100	21100	11600	9900
	50	74.6	19400	19400	9900	8400
	60	71.2	14800	14800	7400	6100
	80	64.0	10400	10400	4400	3400
	100	57.1	7200	7200	2600	1800
	120	48.1	5100	5100		
	140	37.4	3600	3600		
	160	22.8	2500	2500		
180 Ft.	40	78.2	20900	20900	13500	11700
	45	76.5	19100	19100	11400	9700
	50	75.3	16000	16000	9700	8200
	60	72.1	13300	13300	7200	5900
	80	65.3	9900	9900	4200	3200
	100	59.0	6800	6800	2400	1800
	120	51.2	4700	4700		
	140	41.8	3300	3300		
	160	30.0	2200	2200		
	190 Ft.	40	78.7	18000	18000	13300
45		77.0	15700	15700	11200	9600
50		75.9	14500	14500	9500	8000
60		72.9	12000	12000	7100	5800
80		67.1	8700	8700	4000	3000
100		60.0	6400	6400	2200	
120		54.3	4400	4400		
140		45.4	2900	2900		
160		35.3	1800	1800		
200 Ft.		45	78.1	13000	13000	11000
	50	76.4	13000	13000	9400	7800
	60	73.6	8000	8000	6900	5600
	80	68.1	8000	8000	3800	2800
	100	61.8	5400	5400	2100	
	120	56.3	3600	3600		
	140	48.4	2500	2500		
160	39.5	1500	1500			
210 Ft.	50	76.9	10000	10000	9200	7700
	60	74.8	6000	6000	6000	5400
	80	69.1	6000	6000	3700	2700
	100	63.5	4400	4400	1900	
	120	58.3	2800	2800		
	140	51.0	1700	1700		

NOTES:

- Load-handling devices are part of the load. For jibs, see notes 4, 4a and 4b.
- Maximum length of main boom 160 ft.
- Jibs may be used straight or goosenecked. 20 ft. jib is two-piece and may be extended to 50 ft. with center sections. The following data apply:

Jib Lgth.	Radius	Max. Lgth. of Boom Incl. Jib	Maximum Lifting Capacity (Lbs.)					Weight of Jib and Backstays
			0 Ft.	6 Ft.	12 Ft.	18 Ft.	24 Ft.	
20 Ft.	Up thru 50' Over 50'	180 Ft.	26000	19000	16000			1330 lbs.
			20000	17000	14000			
30 Ft.	Up thru 50' Over 50'	190 Ft.	18000	12600	10000			1650 lbs.
			12000	11000	9000			
40 Ft.	Up thru 50' Over 50'	200 Ft.	13000	9500	7200	5300		1970 lbs.
			8000	7500	6000	4200		
50 Ft.	Up thru 50' Over 50'	210 Ft.	10000	7600	6000	5000	4000	2285 lbs.
			6000	5500	5000	5000	3000	

- Cap

MC-550 A

Load Ratings With

RADIUS DIAGRAM:

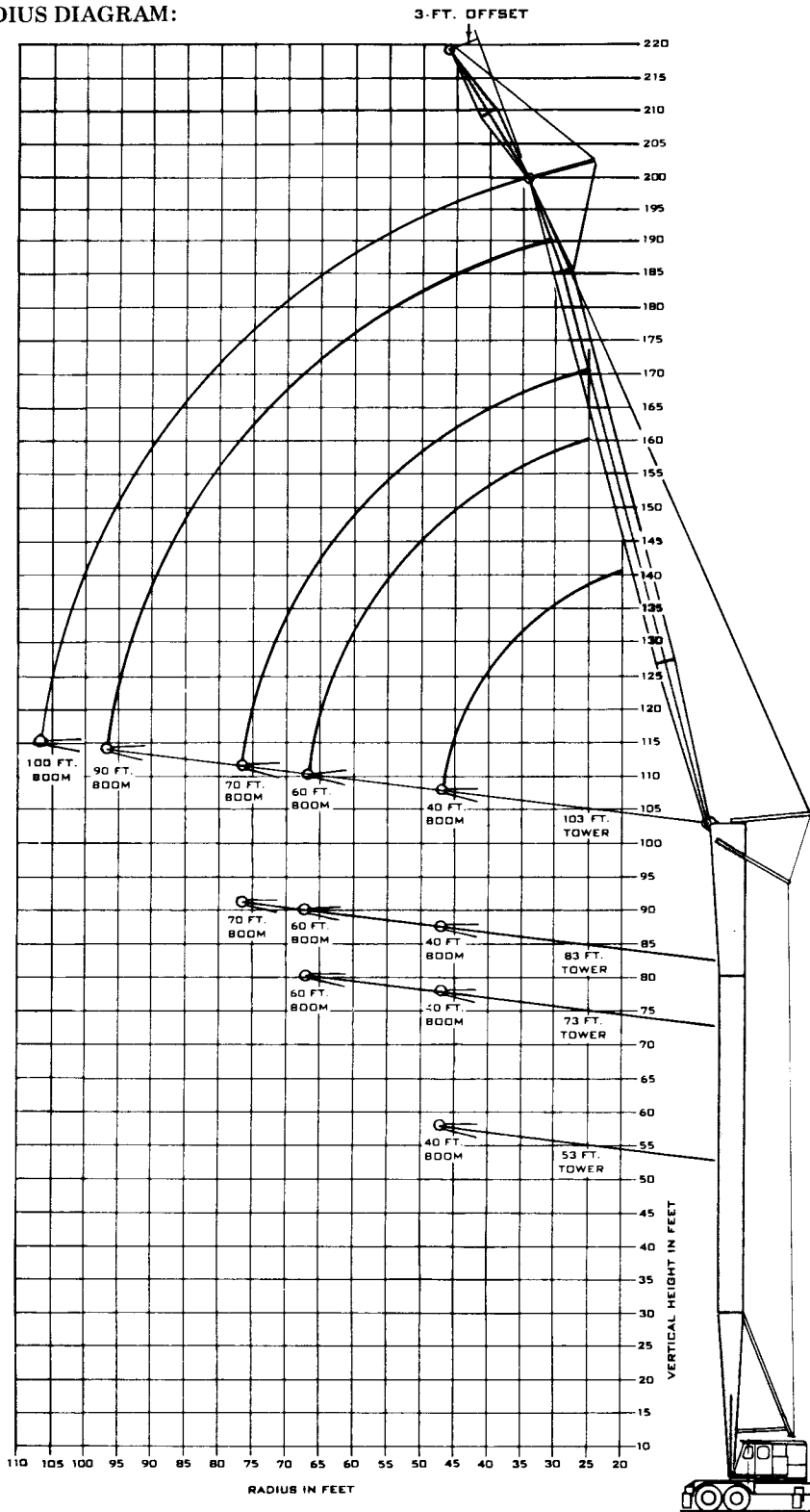

**WORKING
RANGES
MC-550A
MOTO-TOWER**

Tower Attachment

CAPACITY CHART:

Maximum Rated Load In Pounds

103 FT. TOWER (Effective)
97 FT. TOWER (Pin to Pin)

Radius in Ft.	Boom Length in Ft.—Over Rear and Side				
	40'	60'	70'	90'	100'
25	37000				
30	35500	35000	34000		
35	31000	30600	30400	30000	
40	26400	25900	25700	25300	25000
46	19500				
50		19450	19000	18500	18200
60		15200	15000	14600	14300
66		11100	12400	12000	11700
70			11400	10800	10500
76			9000	9200	8900
80				8400	8100
90				6800	6500
96				6000	5700
100					5400
106					5000

83 FT. TOWER (Effective)
77 FT. TOWER (Pin to Pin)

Radius in Ft.	Boom Length in Ft. Over Rear and Side		
	40'	60'	70'
25	37500		
30	36100	35500	35000
35	31300	30600	30400
40	26400	25900	25700
46	19500	21500	21200
50		19700	19200
60		15200	15100
66		11100	12800
70			11600
76			9000

73 FT. TOWER (Effective)
67 FT. TOWER (Pin to Pin)

Radius in Ft.	Boom Length in Ft. Over Rear and Side	
	40'	60'
25	38000	
30	36500	36000
35	31500	30700
40	26400	26000
46	19500	21500
50		19700
60		15200
66		11100

53 FT. TOWER (Effective)
47 FT. TOWER (Pin to Pin)

Boom Length in Ft. Over Rear and Side	
Radius in Ft.	40'
20	55000
25	44000
30	37000
35	31800
40	26500
46	19500

NOTES:

- The rated loads as determined by boom length, radius and weight of load apply to this machine as originally manufactured and equipped and as mounted on a Thew manufactured MC-550A, 8 x 4 carrier. THEY ARE MAXIMUM lifting capacities and comply with standards of the Power Crane & Shovel Association as issued by the U.S. Department of Commerce Commercial Standard CS90-58 and the SAE Crane Load Stability Test Code J765.
- Capacities identified by bold face type are based on structural or machinery strength, not stability. When operating within the ranges covered by capacities in bold face type, do not rely upon machine tipping as the capacity limitation.
- Rated loads are based on 75% of stability with the machine being on a firm, level and uniform supporting surface.
- Before lifting at, or near, rated loads, the machine should be leveled with a commercial level in two directions. FOR SAFE WORKING LOADS THE USER is expected to make due allowances for his particular job conditions such as: Soft or uneven ground, out of level conditions, side loads, pendulum action, jerking or sudden stopping of loads, hazardous conditions, experience of personnel, etc. Side pull on boom or jib is extremely dangerous. CAUTION: The operator and other personnel should fully read and acquaint themselves with Operators Manual furnished by the manufacturer BEFORE operating this machine, and Rules for Safe Operation of equipment should be adhered to at all times. Operators and supervisors should also acquaint themselves with Standard Safety Codes for Cranes, Derricks and Hoists, ASA-B 30.2 - 1943 (R-1952).
- An Overload-Indicator is installed to supplement the operator's judgment and operates as follows. CAPACITIES BASED ON STRENGTH: The amber light is an advanced warning that you are approaching the rated lifting capacity. When the latter is reached, the red light and bell warning will respond. Operations must then be stopped and corrections made before proceeding.
- Rated lifting capacities apply only when tower is erected, with outriggers fully extended to 18 ft. 6 in. from center to center.
- The weights of fall blocks, slings, equalizer beams and all similar load-handling devices are considered part of the load lifted and suitable allowances for them should be made.
- Maximum length of tower - 103 ft. (from ground); 97 ft. (pin to pin).
- Maximum length of boom 100 ft.
- With turntable in forward mounting position, the maximum tower and boom (see notes 3, 3a) may be carried with tower in erected position and with boom lowered against tower, outriggers sufficiently retracted to give ground clearance.
- A 47 ft. tower and 40 ft. boom combination may be travelled over the rear unsupported at speeds not to exceed 5 M.P.H. All other combinations must be supported.
- With turntable in forward mounting position and with outriggers set, the maximum length of tower and boom that may be raised over the rear unassisted is 97 ft. tower (pin to pin) and 90 ft. boom or 100 ft. boom less 15 ft. peak.
- Minimum number of parts of hoist line required is determined by dividing the loads to be lifted by 10,200 lbs. for standard 5/8" hoist cable, or 14,600 lbs. for standard 3/4" hoist cable, with power load lowering. Without power load lowering (whip line) single line pull limited to 5,000 lbs. 3/4" cable with minimum part of line gives highest hoist speed. 5/8" cable with maximum part of line gives lowest hoist speed and best load control.
- The load indicator cams are not interchangeable, and will function properly only if used with tower and boom combination, or tower, boom and jib combination that is stamped on the cams.
- The 20 ft. jib with 3 ft. offset only is applicable to 97 ft. tower and 100 ft. boom combination.

Radius in Ft.	Capacity Over Rear and Side	Radius in Ft.	Capacity Over Rear and Side
45	17000	90	5700
50	14500	100	4700
60	11600	110	4000
70	9300	120	3275
80	7100		

- With load on jib, do not combine simultaneous load hoisting or lowering with boom hoisting or lowering.
- Load should be lifted at 1/2 throttle.
- Minimum radius 45 ft.
- Maximum radius 120 ft.
- When 20 ft. jib is installed, lifting capacities for 97 ft. tower and 100 ft. boom over the boom head must be reduced by 1,525 lbs.

MC-550 A MOTO-TOWER®

GENERAL DIMENSIONS:

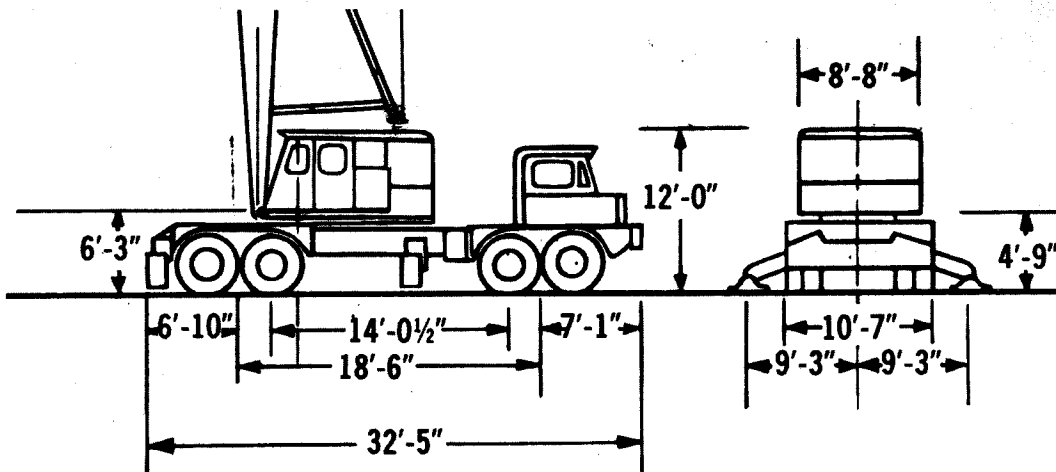

SPECIFICATIONS:

TURNTABLE SPECIFICATIONS

Power	
Gas	GM 4-71N, 6 cyl.
Bore and Stroke	4 1/4 in. x 5 in.
Displacement	284 Cu. in.
Horsepower	115 H.P.
Power Take-Off	Torque Converter
Fuel Tank	50 gals.

Operating Characteristics

Line Pulls and Line Speeds:	
Main Hoist (15" P.D.)	17,250 lbs. @ 170 F.P.M.
Secondary Hoist (15" P.D.)	17,250 lbs. @ 170 F.P.M.
Swing Speed	4.0 R.P.M.
Controls	Manual Mechanical

Other Equipment

Boom Hoist	Planetary Drive, Dual Drum
Gantry	Telescopic Mast Type, Air Operated
Counterweight, Removable	24,900 lbs.
Turntable Connection	External Gear Shear-Ball®

MOTO-CRANE SPECIFICATIONS

Power	
Gas	GM 6-71N, 6 cyl.
Bore and Stroke	4 1/4 in. x 5 in.
Displacement	425.6 cu. in.
Horsepower	246 H.P.
Power Take-Off	Plate Clutch
Fuel Tank	80 gals.

Transmissions

Main Transmission	5 Speeds
Auxiliary Transmission	4 Speeds
Total Speeds Forward	20
Total Speeds in Reverse	4

Speeds

Low-low	1.5 M.P.H.	High-high	44 M.P.H.
---------	------------	-----------	-----------

Outriggers Power-Set®, Hydraulically Operated, complete with floats

Rear Bogie

Axles (Planetary) Double Reduction Gear Drive
 First reduction thru hypoid gears; final reduction thru planetary wheel hubs; high-traction differentials. Interaxle differential with lockout.
 Mounting—Two axles in tandem, with "through-drive", mounted on equalizer beams.

Front Tandem	Two non-driving axles mounted on equalizer beams.
Steering	Centralized Hydraulic Power Assist
Turning Radius (to Front Corner of Vehicle)	54 ft. 2 in.
Brakes (Spring Set for Emergency and Parking)	Air
Rear	4 Brakes; 17 1/4 in. dia. x 5 1/2 in. wide
Front	4 Brakes; 17 1/4 in. dia. x 4 in. wide
Tires (Tube)	14:00 x 20, 18 P.R.

BOOM EQUIPMENT

Crane Boom	
Design	Square-Tubular-Chords
Type of Connection	Pin Connected
Basic Length	See Range Diagram
Number of Hoist Line Sheaves at Boom Head on anti-friction bearings	4

Jib

Two-Piece Pin-Connected Type	20 ft.
------------------------------	--------

Lifting Crane Component

Lagging	Two, 15-inch P.D.
Floating Harness	10 parts of line
Boom Lowering	by Power, Clutch Controlled
Boom Stops	Cable Type
Swing Brake	Standard
Power Load Lowering (right hand hoist drum)	Available
Third Drum	Available

TOWER EQUIPMENT

Tower	
Design	Square-Tubular-Chords
Type of Connection	Pin Connected
Tower Height	See Range Diagram
Top Section	Includes 2 pendants, 2 boom masts
Boom Position Indicator	Standard
Overload-Indicator	Available

APPROXIMATE SHIPPING WEIGHTS*

Standard Machine Equipped as,	
53-ft. Tower with 40-ft. Boom	117,705 lbs.
103-ft. Tower with 100-ft. Boom	126,200 lbs.

*Removable counterweight can reduce weight 24,900 lbs. Additional reduction may be made by removing outrigger boxes and beams.

MC-550 A MOTO-CRANE®

LOAD DISTRIBUTION:

	Gross Weight	Turntable Facing Front		Turntable Facing Rear	
		Front	Rear	Front	Rear
1. Complete Basic Crane. Mast Down. Boom In Travel Position. Hoist and Whip Cables On Drums. Fuel Tanks Full. 175 # Man In Truck Cab	99190	15735	83455	37675	61515
2. (a) Add Power Load Lowering	+1225	+50	+1175	+250	+975
(b) Add P.L.L. When 3rd. Drum is Installed	+170	0	+170	+45	+125
3. (a) Add 3rd. Drum Only	+1295	+65	+1230	+250	+1045
(b) Add 3rd. Drum when P.L.L. is Installed	+240	+10	+230	+45	+195
4. Add Cummins V-504-C w/Torque Converter.....	+210	-40	+250	+95	+115
5. Add Cummins NHC-250 to Carrier	+735	+835	-100	+835	-100
6. Add 50 Ton 4-Sheave Block to Boom Peak	+850	+2075	-1225	-1840	+2690
7. Add 50 Ton 4-Sheave Block to Front Bumper	+850	+1210	-360	—	—
8. Remove Counterweight	-24900	+8970	-33870	-16355	-8545
9. Remove Rear Outrigger Box and Beams	-4170	+1240	-5410	+1240	-5410
10. Remove Front Outrigger Box and Beams	-4170	-2190	-1980	-2190	-1980
11. Remove 15' Boom Peak and Pendants	-1520	-2890	+1370	+2440	-3960
12. (a) Remove Complete 40' D15-4 Boom, Pendants, Mast Harness and Telescoping Mast	-5665	-6585	+920	+4905	-10570
(b) Remove Boom Stops	-400	-105	-295	0	-400
13. Adjustment Counterweight Carried Behind Carrier Cab	0	+25325	-25325	0	0