

# Technical Data

## Specifications & Capacities

# 238

HYLALAB

**HSL Crawler Crane**  
150 Ton (136 metric ton)

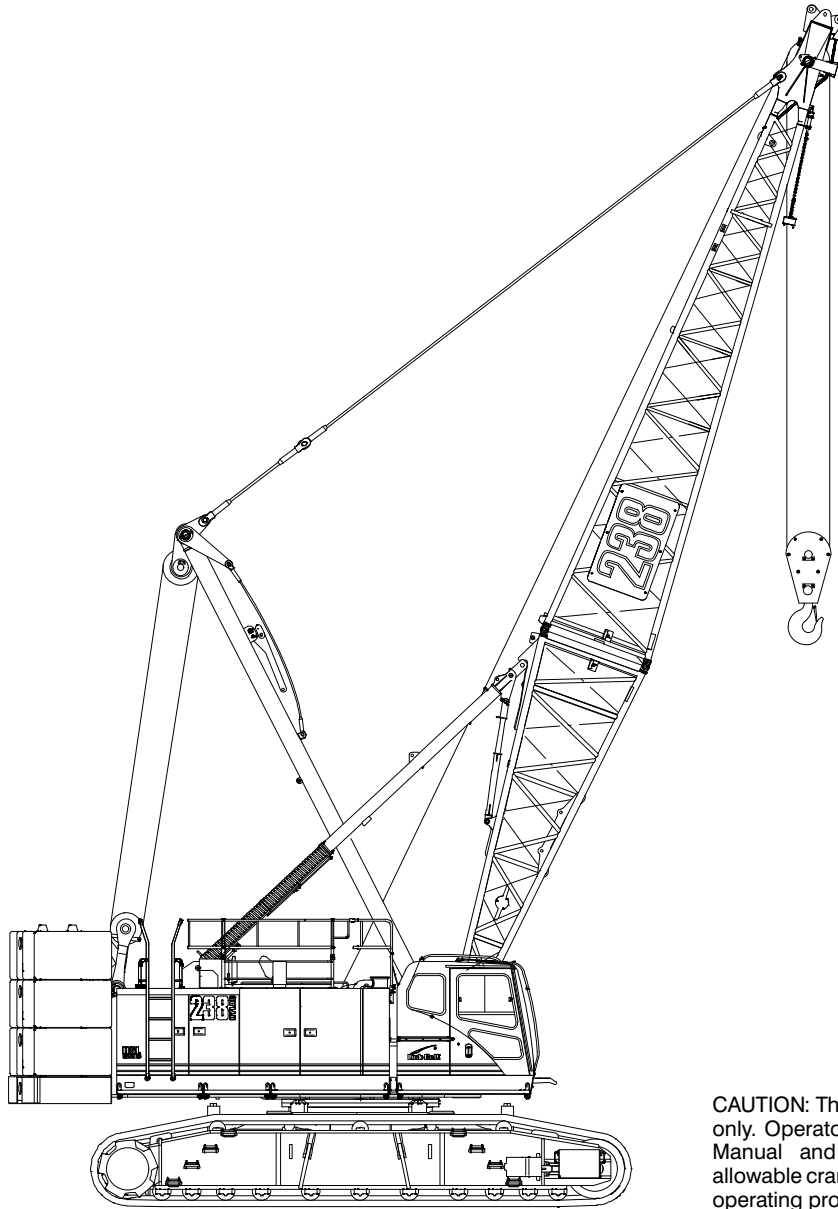

**CAUTION:** This material is supplied for reference use only. Operator must refer to in-cab Crane Rating Manual and Operator's Manual to determine allowable crane lifting capacities and assembly and operating procedures.



# Table Of Contents

<b>Upper Structure</b> .....	<b>1</b>
Frame .....	1
Engine .....	1
Hydraulic System .....	1
Load Hoist Drums .....	1
Optional Front–Mounted Third Hoist Drum .....	1
Boom Hoist Drum .....	2
Swing System .....	2
Counterweight .....	2
Operator Cab .....	2
Rated Capacity Limiter System .....	2
Boom Hoist System .....	2
Machinery Cab .....	2
Catwalks .....	2
<b>Lower Structure</b> .....	<b>3</b>
Carbody .....	3
Side Frames .....	3
Travel and Steering .....	3
Jack System .....	3
<b>Attachment and Options</b> .....	<b>3</b>
Conventional Tube Boom .....	3
Tubular Jib .....	4
Luffing Boom .....	4
Auxiliary Tip Extension .....	4
Luffing Jib .....	4
Fixed Jib .....	4
<b>Dimensions</b> .....	<b>5</b>
Base Crane .....	7
Side Frames .....	7
Upper Counterweights .....	8
Boom/Luffing Boom .....	9
Jib .....	11
Hook Balls .....	12
Luffing Jib .....	12
Hook Blocks .....	13
<b>Working Weights</b> .....	<b>14</b>
<b>Transport Weights</b> .....	<b>14</b>
<b>Transport Drawings</b> .....	<b>15</b>
<b>Load Hoist Performance</b> .....	<b>17</b>
<b>Working Areas</b> .....	<b>18</b>
<b>Attachments</b> .....	<b>19</b>
<b>Main Boom Make–up</b> .....	<b>20</b>
<b>Main Boom Working Range Diagram</b> .....	<b>21</b>
<b>Main Boom Load Charts</b> .....	<b>22</b>

**This Page Intentionally Blank**

# Upper Structure

## Frame

All welded and precision machined surfaces for mating parts.

### Turntable Bearing

- Inner race with internal swing gear is bolted to lower frame.
- Outer race is bolted to upper frame.

## Engine

### Engine

Full pressure lubrication, oil filter, air cleaner, hour meter, throttle, and electric control shutdown.

Isuzu 6HK1—T4i	
Number of cylinders	6
Bore and stroke	4.53 x 4.92 in (115 x 125mm)
Piston displacement	475 in <sup>3</sup> (7.8L)
Engine rpm at full load speed	1,900 rpm
Hi-idle rpm	1,900 rpm
Gross engine hp	282 hp (210kw)
Peak torque	797 ft lb (1 080joule) @ 1,500 rpm
Electrical system	24 volt
Fuel tank capacity	122 gal (460L)
Batteries	2—12 volt
Approximate fuel consumption	gal/hr (L/hr)
100% hp	12.10 (45.80)
75% hp	9.06 (34.30)
50% hp	6.37 (24.11)
25% hp	3.33 (12.60)

### Fuel Tank

Equipped with fuel sight level gauge.

## Hydraulic System

### Hydraulic Pumps

The pump arrangement is designed to provide hydraulically powered functions allowing positive, precise control with independent or simultaneous operation of all crane functions.

- Two variable displacement pumps operating at 4,553 psi (320kg/cm<sup>2</sup>) and 70.3 gal/min (266L/min) powers load hoist drums, boom hoist drum, optional third drum, and travel.
- One variable displacement pump operating at 2,987 psi (210kg/cm<sup>2</sup>) and 40.2 gal/min (152L/min) powers the swing motors, lower jacks, counterweight removal, and side frame extend/retract.
- One fixed displacement gear type pump operating at 1,422 psi (100kg/cm<sup>2</sup>) and 10.3 gal/min (39L/min) powers the pilot control system, clutches, brakes, and pump controls.
- Two fixed displacement gear type pumps operating at 10.3 gal/min (39L/min) powers the hoist brake cooling system.

### Hydraulic Reservoir

84.5 gal (320L), equipped with sight level gauge. Diffusers built in for deaeration.

### Filtration

Ten micron, full flow, line filter in the control circuit. Oil is filtered prior to entering the reservoir.

### Counterbalance Valves

All hoist motors are equipped with counterbalance valves to provide positive load lowering and prevent accidental load drop if the hydraulic pressure is suddenly lost.

## Load Hoist Drums

Each drum contains an axial piston variable speed hydraulic motor with individual automatic winch motor brakes. Power flow is directed through a “wet” style multi-disc brake.

- Power up/down and free-fall operation modes
- Automatic brake mode (spring applied, hydraulically released, wet type brake)
- Drum laggings grooved for wire rope
- Drum pawls controlled manually
- Electronic drum rotation indicators
- Mounted on anti-friction bearings
- 21.81 in (55.40cm) root diameter
- 37.80 in (96.01cm) flange diameter
- 25.26 in (64.16cm) width

The free-fall operation mode is designed to prevent load lowering even if the free-fall switch is accidentally activated.

The automatic brake mode meets all OSHA requirements for personnel handling.

## Optional Front-Mounted Third Hoist Drum

Mounts in the boom base section and is used in conjunction with a fleeting sheave and 3-sheave idler assembly to run the wire rope over the boom top section.

- Power up/down for luffer applications where a second load line is needed
- Controlled free spooling capability for pile driving applications
- 18.75 in (47.63cm) root diameter
- 27 in (68.58cm) flange diameter
- 24 in (60.96cm) width
- Mounted on anti-friction bearings

## Boom Hoist Drum

Contains a pilot controlled, bi-directional, axial piston motor and a planetary gear reduction unit to provide positive control under all load conditions.

- Spring applied, hydraulically released, disc type brake controlled automatically
- Drum lagging grooved for wire rope
- Electronic drum rotation indicators
- Drum pawl controlled automatically
- Mounted on anti-friction bearings
- 20.89 in (53.06cm) root diameter
- 36.22 in (92.00cm) flange diameter
- 11.57 in (29.39cm) width

## Swing System

Pilot controlled bi-directional axial piston motors and planetary gear reduction units to provide positive control under all load conditions.

- Spring applied, hydraulically released, 360° multi-plate brake
- Free swing mode when lever is in neutral position
- Four position positive house lock
- Two-speed swing
- Audio/Visual swing alarm
- Maximum swing speed is 1.7 rpm

## Counterweight

Consists of a seven-piece design that can be easily lowered to the ground using the removal cylinders.

- “A” upper counterweight consists of one 20,000 lb (9 072kg) base slab.
- “B” upper counterweight consists of one 15,000 lb (6 804kg) and one 14,200 lb (6 441kg) wing weights.
- “C” upper counterweight consists of one 15,000 lb (6 804kg) and one 14,200 lb (6 441kg) wing weights.
- “D” upper counterweight consists of one 15,000 lb (6 804kg) and one 14,200 lb (6 441kg) wing weights.

Total combined counterweight “ABCD” is 107,600 lb (48 807kg).

## Operator Cab

Fully enclosed modular steel compartment is independently mounted and padded to protect against vibration and noise.

- All tinted/tempered safety glass
- Sliding entry door
- 18,750 BTU/hr hot water heater
- 15,880 BTU/hr air conditioner
- Door and window locks
- Circulating fan
- Sun visor
- Cloth seat
- Windshield wipers and washer
- Dry chemical fire extinguisher
- Electronic drum rotation indicators for front, rear, and boom hoist drums
- Rearview camera
- Six way adjustable seat
- Hand and foot throttle
- Fully adjustable single axis controls
- Swing lever with swing brake and horn located on handle
- Bubble type level
- Ergonomic gauge layout
- Controls shut off lever
- Control stand is adjustable for operator comfort.
- Swing brake foot pedal

## Rated Capacity Limiter System

The HSL rated capacity limiter system is a boom hoist load cell system. This system provides the operator with useful geometrical data, to include:

- Main Boom Length
- Main Boom Angle
- Jib Length
- Jib Angle
- Operating Mode
- Load Radius
- Boom Tip Height
- Audible Alarm
- Pre-Warning Light
- Overload Light
- Load On Hook
- Function kick-outs including over load
- Operator settable stops (ramped stops)
- Anti-Two Block Indicator
- Boom hoist dead end load cell (no liners)

## Boom Hoist System

Designed to lift off maximum boom or maximum boom plus jib unassisted. Operates up to a maximum boom angle of 80° for conventional boom and 88° for luffing boom. Boom hoist limit system limits maximum boom angle operation.

- Pin-on bail frame
- 14-part reeving with 7/8 in (22mm) wire rope
- 26 ft (7.92m) live mast
- Tubular boom backstops (telescopic type)
- Sheaves contain sealed anti-friction bearings

## Machinery House

Hinged doors (on right and left sides) for machinery access. Equipped with rooftop access ladder and skid resistant finish on roof.

## Catwalks

Standard on right and left sides. Catwalks fold up and pin for reduced travel width.

# Lower Structure

## Carbody

### Lower Frame

All welded construction frame with precision machined surfaces for turntable bearing and rotating joint.

- 9 ft 5 in (2.87m) overall width
- 15 ft 7 in (4.75m) overall length

## Side Frames

### Side Frames

All welded, precision machined, hook and pinned steel frames

- 17 ft 8.6 in (5.40m) gauge
- 25 ft 11.5 in (7.91m) overall length
- 44 in (1.12m) wide track shoes
- Sealed (oil filled) drive planetaries
- Compact travel drives
- Automatic hydraulic track adjustment system — optional

### Track Rollers

- Eleven sealed (oil filled) track rollers per side frame
- Heat treated, mounted on oil filled anti-friction bearings

### Tracks

Heat treated, self-cleaning, multiple hinged track shoes joined by one-piece full floating pins; 56 shoes per side frame

### Take Up Idlers

Cast steel, heat treated, self-cleaning, mounted on aluminum/bronze bushings. Lubricated through idler shaft.

- **Track Tension Adjustment** — Idler wheel adjusted by means of hydraulic cylinder and hand pump. Idler wheel shaft held in position with shims after adjustment is made.

## Travel and Steering

### Travel and Steering

Each side frame contains a pilot controlled, bi-directional, axial piston motor and a planetary gear reduction unit to provide positive control under all load conditions.

- Individual control provides smooth, precise maneuverability including full counter-rotation.
- Spring applied, hydraulically released disc type brake controlled automatically
- Maximum travel speed is 1 mph (1.6km/h).
- Designed to 30% gradeability

## Jack System

System contains four hydraulic cylinders individually pinned on swing out beams.

- Individual controls are mounted on carbody.
- Minimum height of carbody when resting on pontoons is 16.5 in (0.42m).
- Maximum height of carbody when resting on pontoons is 43.7 in (1.11m).

# Attachment and Options

## Conventional Tube Boom 50–260 ft (15.24–79.25m)

### Basic Boom

50 ft (15.24m) two-piece design that utilizes a 20 ft (6.10m) base section and a 30 ft (9.14m) open throat top section with in-line connecting pins on 70 in (1.78m) wide and 62 in (1.57m) deep centers.

- Boom foot on 53.15 in (1.35m) centers
- 4 in (10.16cm) diameter chords
- Lugs on base section to attach carrying links
- Deflector roller on top section
- Permanent skid pads mounted on top section to protect head machinery

- Five 21.53 in (54.69cm) root diameter polyamide sheaves mounted on sealed anti-friction bearings
- Tip extension and jib connecting lugs on top section
- Mechanical boom angle indicator

### Tube Boom Extensions

The following table provides the lengths available and the suggested quantity to obtain maximum boom in 10 ft (3.05m) increments. Midpoint pendant connections are required at 120 ft (36.58m) for boom lengths of 230 ft (70.10m) and longer.

- Polyamide wear blocks on top of each extension
- Appropriate length wire rope pendants stored on extension. Pendants are 1.38 in (34.93mm) diameter type "LB".
- Lifting lugs

Tube Boom Extensions		Quantity For Max Boom
ft	m	
10	3.05	2*
20	6.10	2
30	9.14	1
40	12.19	3

\* Assumes one 10 ft (3.05m) extension is the self-assembly section.

- Maximum tip height of 264 ft 1 in (80.49m)
- Boom connecting pins storage on each extension

## Tubular Jib 30–80 ft (9.14–24.38m)

### Basic Tubular Jib

30 ft (9.14m) two-piece design that utilizes a 15 ft (4.57m) base section and a 15 ft (4.57m) top section with in-line connecting pins on 32 in (0.81m) wide and 24 in (0.61m) deep centers.

- 2.25 in (57.15mm) diameter tubular chords
- One 20.62 in (52.37cm) root diameter steel sheave mounted on sealed anti-friction bearings
- 10 ft (3.05m) and 20 ft (6.10m) jib extensions provide jib lengths of 40 ft (13.72m) to 80 ft (24.38m) in 10 ft (3.05m) increments for tube boom.
- Jib offset angles at 5°, 15°, and 25°
- The maximum tip height of tube boom + jib [230 ft + 80 ft (70.10 + 24.38m)] is 308 ft (93.88m).
- Can be used as fixed jib on luffing jib

## Luffing Boom 85–165 ft (25.91–50.29m)

85 ft (25.91m) five-piece design utilizes a 5 ft (1.52m) luffing boom top section, 20 ft (6.10m) luffing boom base section, 10 ft (3.05m) self assembly section, 10 ft (3.05m) extension, and 40 ft (12.19m) extension with in-line connecting pins. Boom extensions are 70 in (1.78m) wide and 62 in (1.57m) deep at the centers.

- Common base and extensions as open throat boom ("FD" boom only)
- 10 ft (3.05m) self assembly section required for bail anchor
- Working angles of 88°, 85°, 80°, 75°, 70°, and 65°
- Working lengths of 85 ft (25.91m) to 165 ft (50.29m).

### Luffing Boom Extensions

The following table provides the lengths available and the suggested quantity to obtain the maximum luffing boom in 10 ft (3.05m) increments. Midpoint pendants are not required.

Luffing Boom Extensions "FD"		Quantity For Max Boom
ft	m	
10*	3.05	2
20	6.10	1
30	9.14	2
40	12.19	2

\* One 10 ft (3.05m) extension is the self assembly section. Required for luffer operation.

- Rear hoist drum becomes luffing jib hoist
  - Optional third drum provides second working hoist line, if required.
  - Designed for self-assembly
  - Luffing jib hoist bridle and bail can remain reeved for crane transport
  - Job site mobility with attachment
  - Rolled out or rolled under erection methods
  - Compact transport module

## Auxiliary Tip Extension

Designed to use in place of jib to provide clearance between working hoist lines. The extension is equipped with two nylon 18 in (45.72cm) root diameter sheaves mounted on sealed anti-friction bearings. Maximum capacity is 18.5 Ton (16.78mt).

## Luffing Jib 80–160 ft (24.38–48.77m)

### Basic Luffing Jib

80 ft (24.38m) four-piece design utilizes a 20 ft (6.10m) luffing jib base section, 10 ft (3.05m) extension, 30 ft (6.10m) extension, and 20 ft (6.10m) top section with in-line connecting pins. Jib extensions are 32 in (0.81m) wide and 24 in (0.61m) deep at the centers.

- 27 Ton (24.50mt) maximum capacity
- Working lengths of 80 ft (24.38m) to 160 ft (48.77m)

- Top section includes mounting lugs for all attachment options
- Lugs on base section to attach fanpost transport links
- Two steel 18.38 in (46.69cm) root diameter luffing jib head sheaves
- Two polyamide 18 in (45.72cm) diameter luffing boom auxiliary head sheaves
- Pin-on nose wheel
- Eight-part luffing jib hoist
- 1.25 in (31.75mm) diameter type "DB" pendants

### Luffing Jib Extensions

The following table provides the lengths available and the suggested quantity to obtain the maximum luffing jib in 10 ft (3.05m) increments. Midpoint pendants are not required.

Luffing Jib Extensions		Quantity For Max Luffing Jib
ft	m	
20	6.10	1
30	9.14	2

### Notes:

These extensions, combined with extensions included in basic luffing jib make up all luffing jib lengths to 160 ft (48.77m).

40 ft (12.19m) of extensions included in basic jib.

- Wear bar on top of each extension
- Appropriate length pendants
- Maximum luffing jib tip height of 327.14 ft (99.71m)

## Fixed Jib 30 ft (9.14m)

30 ft (9.14m) two-piece design that utilizes a 15 ft (4.57m) base section and a 15 ft (4.57m) top section with in-line connecting pins on 32 in (0.81m) wide and 24 in (0.61m) deep centers.

- 2.25 in (57.15mm) diameter chords
- One 20.62 in (52.37cm) root diameter steel sheave mounted on sealed anti-friction bearings
- Fixed jib offset angle is 5°



# Dimensions

General Dimensions	English	Metric
Basic Boom	50 ft	15.24m
Minimum Load Radius	12 ft	3.66m
Maximum Boom Angle	80°	80°
Track Shoe Width	44 in	1.12m

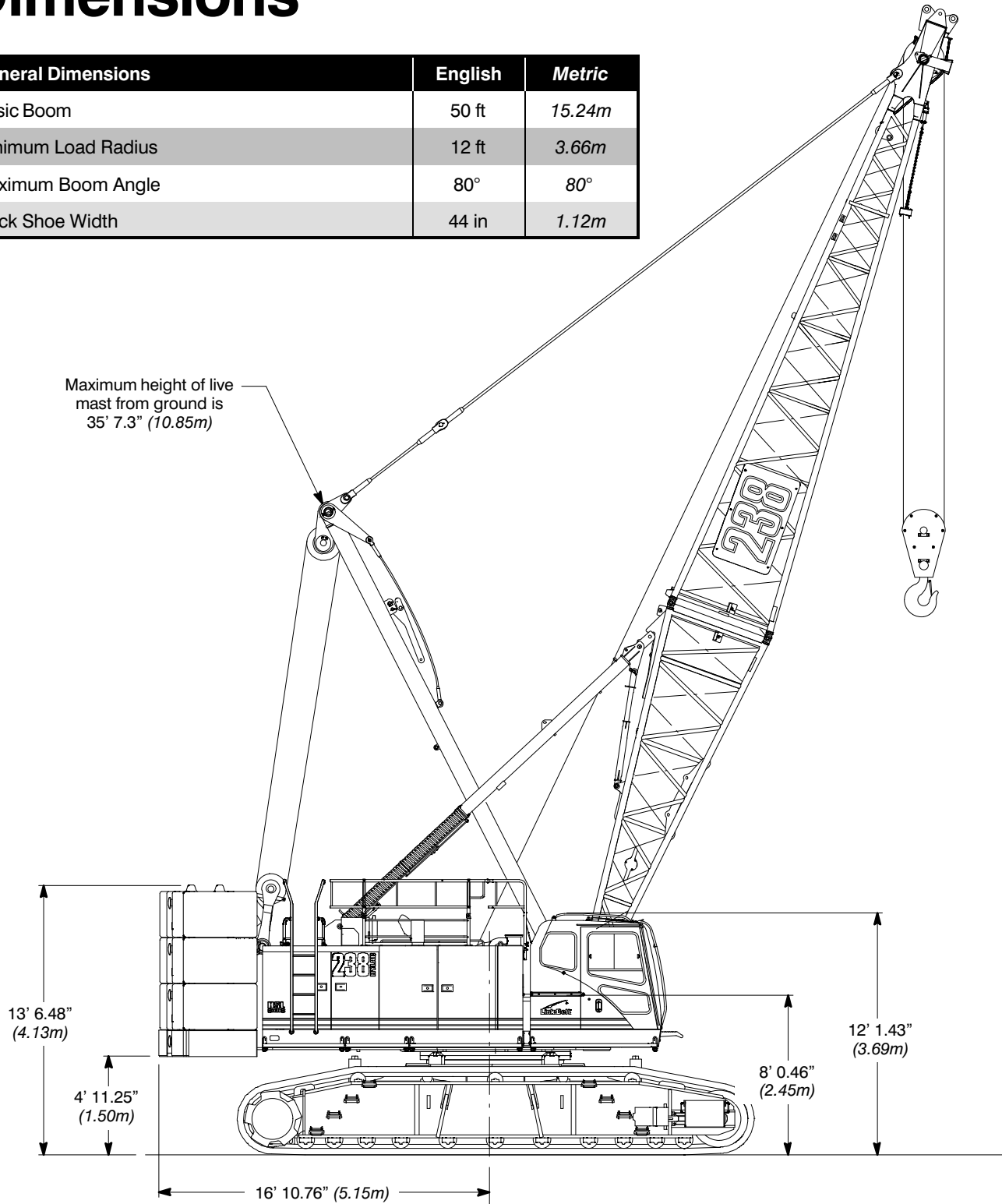

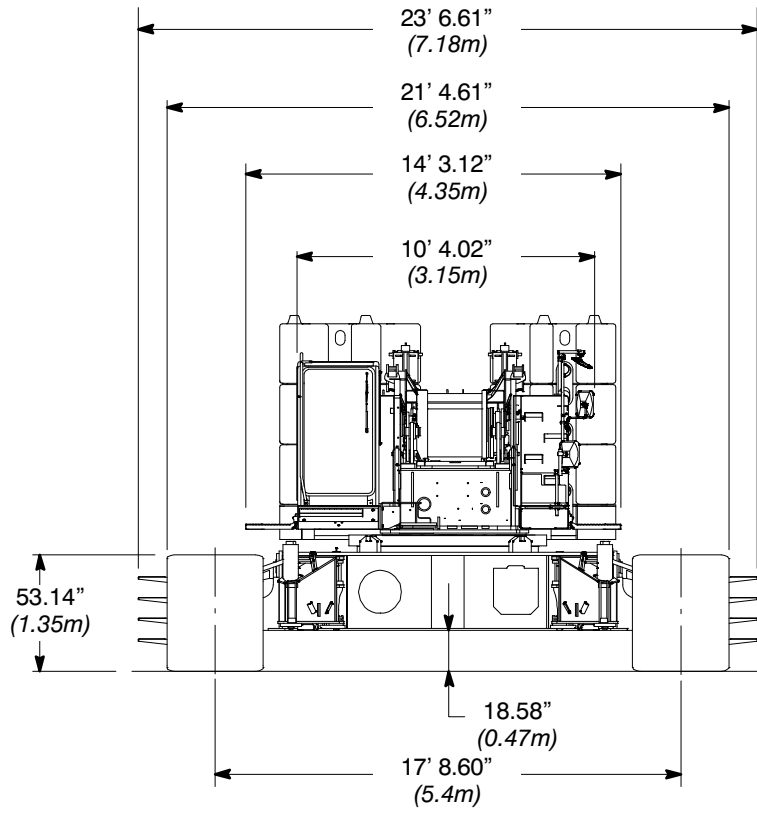
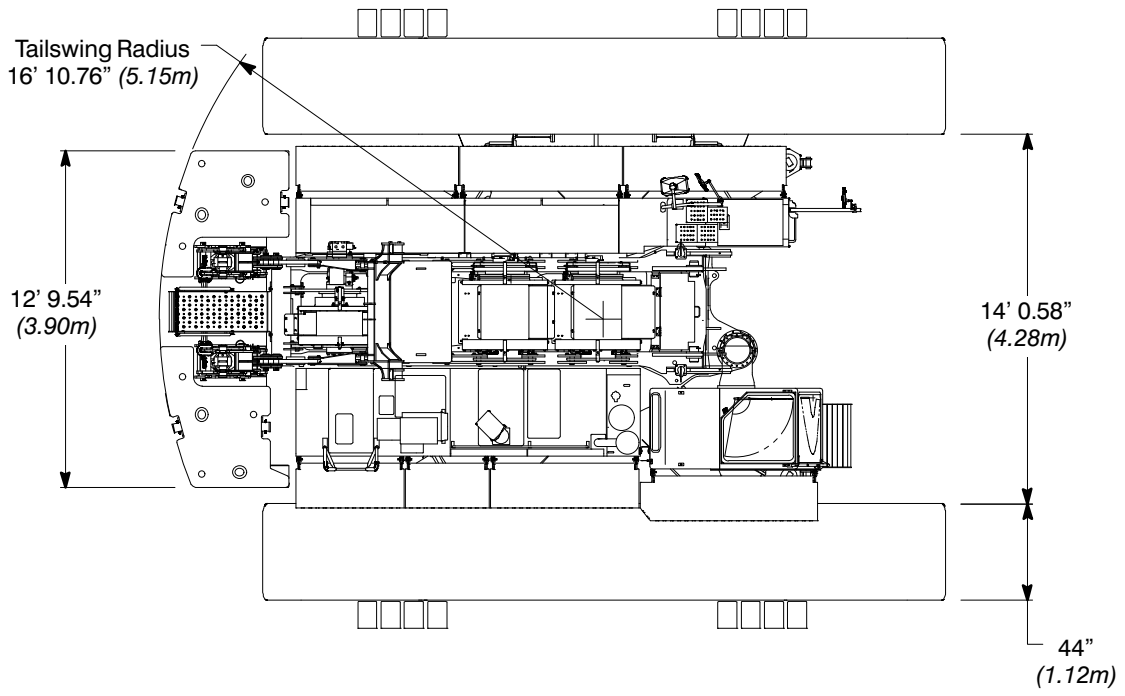

# Base Crane

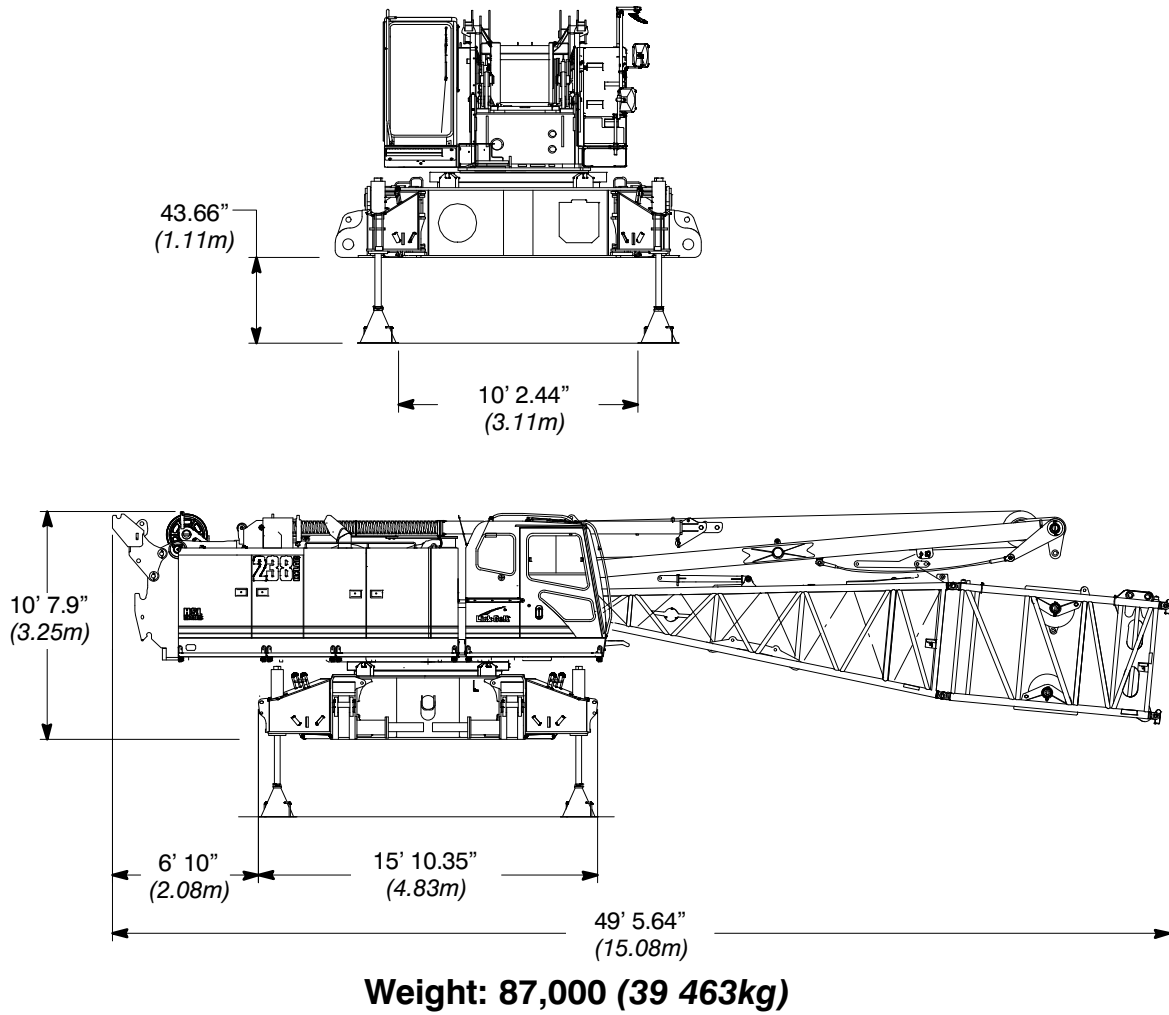

# Side Frames

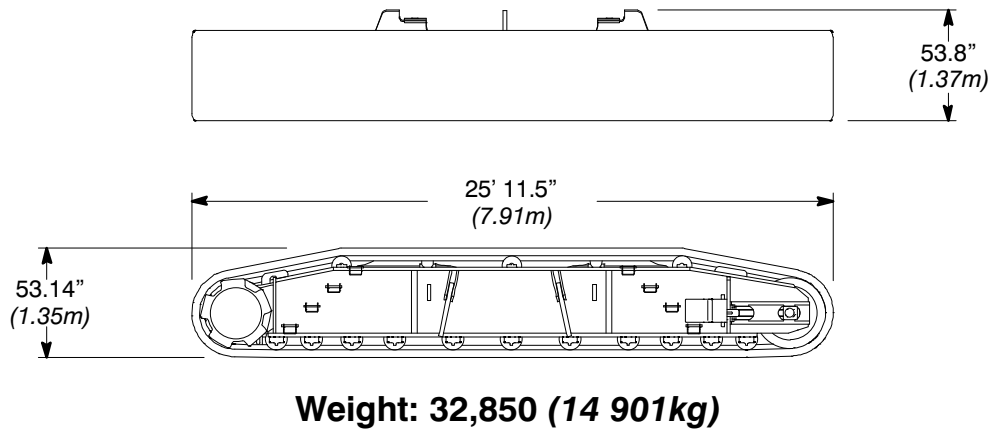

# Upper Counterweights

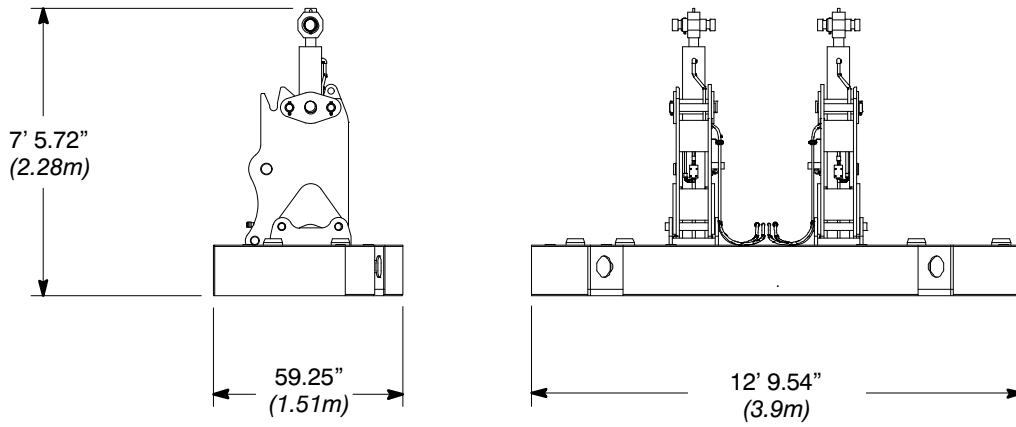

**Weight: 20,000 (9 072kg)**

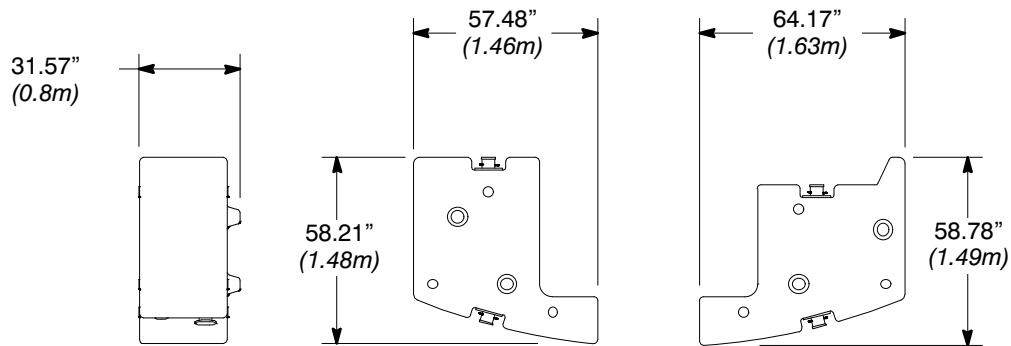

**Weight:**  
**Left Side 15,000 (6 804kg)**  
**Right Side 14,200 (6 441kg)**

# Boom/Luffing Boom

70 in (1.78m) x 62 in (1.57m)

## Boom/Luffing Boom Extensions

Weights Include Pendants and Hardware

### 10 ft (3.05m) Extension

Weight: 1,032 lb (468kg)

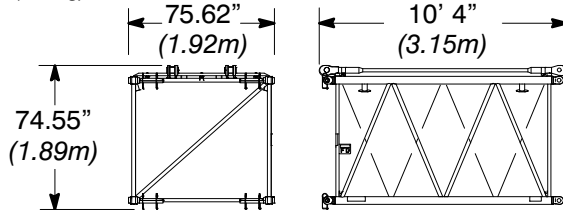

### 20 ft (6.10m) Extension

Weight: 1,656 lb (751kg)

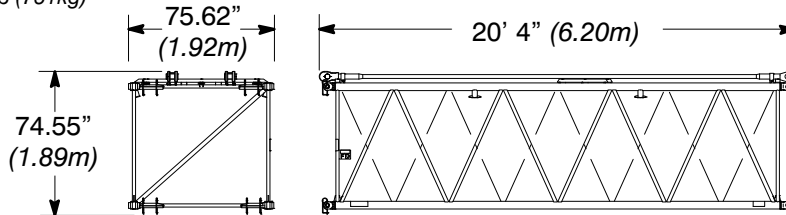

### 30 ft (9.14m) Extension

Weight: 2,284 lb (1 036kg)

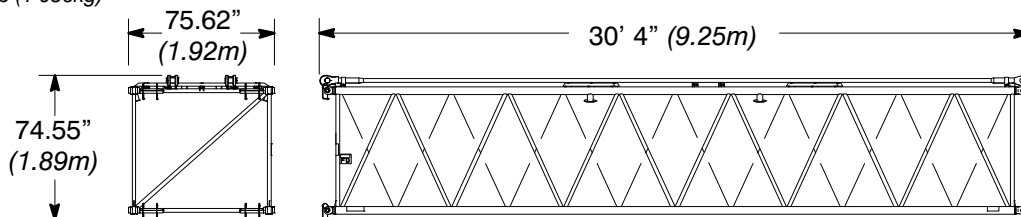

### 40 ft (12.19m) Extension

Weight: 2,908 lb (1 319kg)

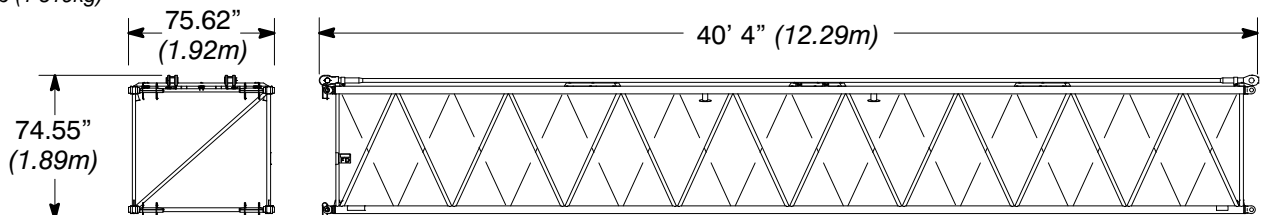

### 30 ft (9.14m) Boom Top Section ①

Length	32 ft 10 in	(10.01m)
Width	79.31 in	(1.88m)
Deep	62 in	(1.57m)
Height	72.10 in	(1.83m)
Weight	4,250 lb	(1 928kg)

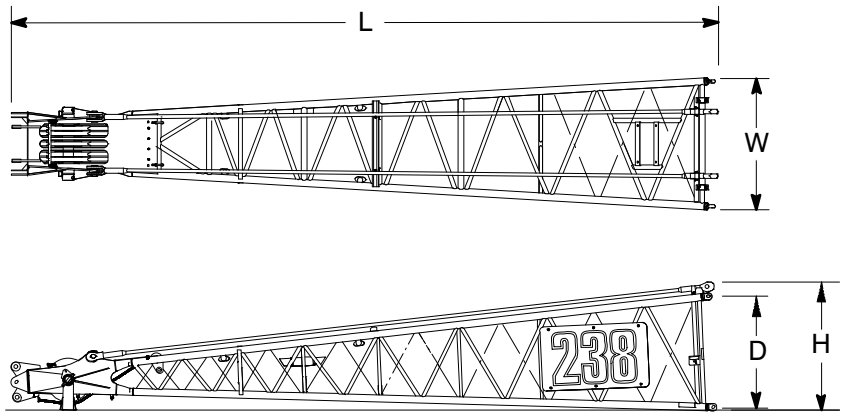

### 20 ft (6.10m) Boom Base Section ①

Length	20 ft 8 in	(6.30m)
Width	75.62 in	(1.92m)
Deep	62 in	(1.57m)
Height	70.89 in	(1.80m)
Weight	2,965 lb	(1 345kg)

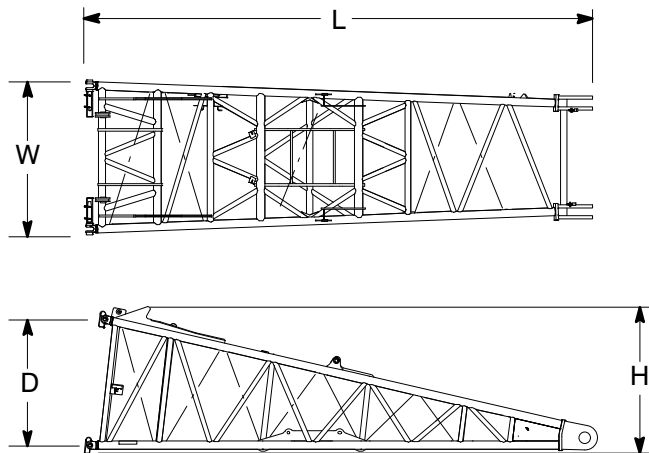

### 10 ft (3.05m) Self Assembly Section\* ①

Length	10 ft 4 in	(3.15m)
Width	75.62 in	(1.92m)
Deep	62.00 in	(1.57m)
Height	73.56 in	(1.87m)
Weight	3,230 lb	(1 465kg)

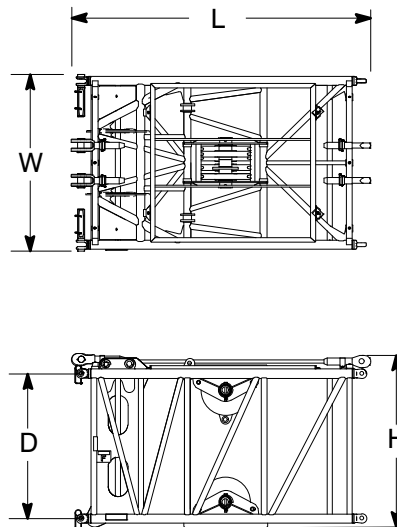

Number inside black circle “①” = # of components  
 \* – Optional equipment

### Auxiliary Tip Extension\* ①

Length	68.38 in	(1.74m)
Width	23.00 in	(0.58m)
Height	41.12 in	(1.04m)
Weight	736 lb	(334kg)

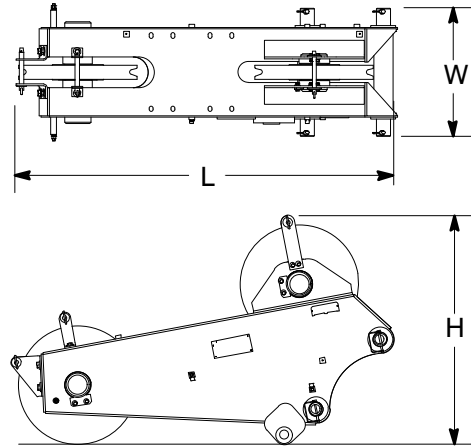

## Jib

### 15 ft (4.57m) Jib Top Section\* ①

Length	16 ft 6.62 in	(5.04m)
Width	34.25 in	(0.87m)
Height	26.81 in	(0.68m)
Weight†	631 lb	(286kg)

† Weight includes pendants and hardware.

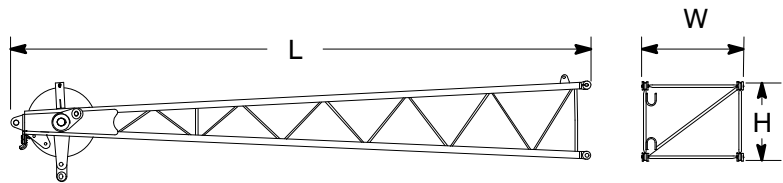

### 15 ft (4.57m) Jib Base Section\* ①

Length1	18 ft 4.86 in	(5.61m)
Length2	15 ft 3.50 in	(4.66m)
Width	34.25 in	(0.87m)
Height 1	27.03 in	(0.69m)
Height 2	76.16 in	(1.93m)
Weight†	1,697 lb	(770kg)

† Weight includes pins, basic frontstay & backstay pendants, and hardware.

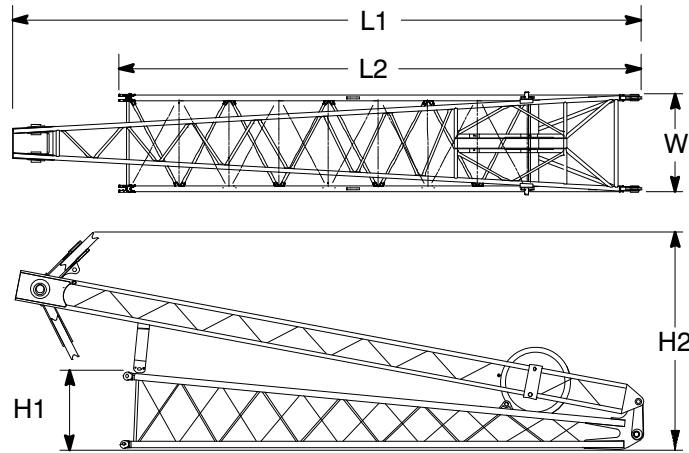

### 10 ft (3.05m) Jib Extensions\* ①

Length	10 ft 0.76 in	(3.12m)
Width	34.25 in	(0.87m)
Height	26.75 in	(0.68m)
Weight†	226 lb	(103kg)

† Weights includes pins, pendants, and hardware.

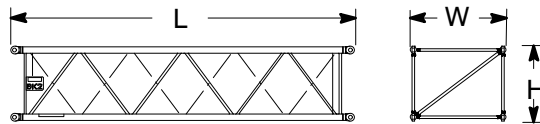

### 20 ft (6.10m) Jib Extensions\* ①

Length	20 ft 0.22 in	(6.17m)
Width	34.25 in	(0.87m)
Height	26.75 in	(0.68m)
Weight†	396 lb	(180kg)

† Weights includes pins, pendants, and hardware.

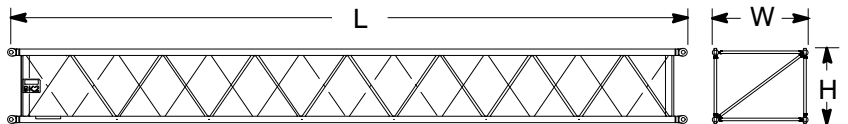

Number inside black circle “①” = # of components  
 \* — Optional equipment

# Luffing Jib

## 20 ft (6.10m) Luffing

### Jib Base Section\* ①

Length	20 ft 5.94 in	(6.25m)
Width	66.18 in	(1.68m)
Height	52.32 in	(1.33m)
Weight†	1,540 lb	(699kg)

† Weight includes pendants and hardware.

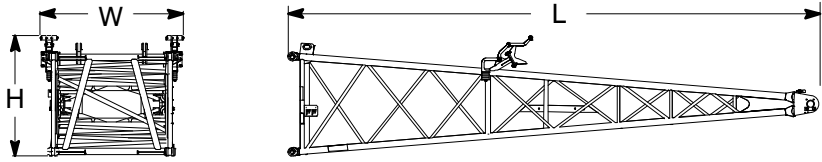

## 20 ft (6.10m) Luffing

### Jib Top Section\* ①

Length	21 ft 10.3 in	(6.66m)
Width	56.82 in	(1.44m)
Height1	50.64 in	(1.29m)
Height2	50.77 in	(1.29m)
Weight†	1,900 lb	(862kg)

† Weight includes hardware.

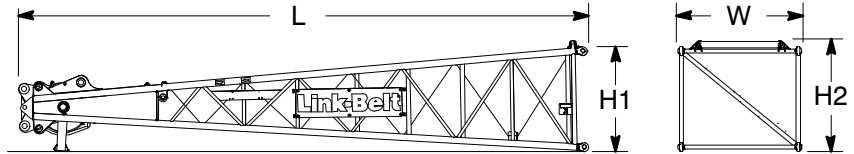

## Luffing Jib Extensions\*

Weights Include Pendants and Hardware

### 10 ft (3.05m) Extension

Weight: 686 lb (311kg)

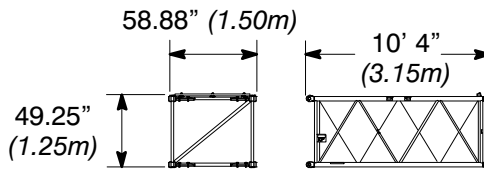

### 20 ft (6.10m) Extension

Weight: 1,087 lb (493kg)

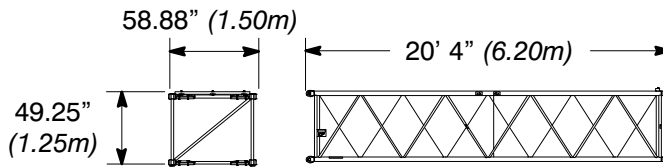

### 30 ft (9.14m) Extension

Weight: 1,500 lb (680kg)

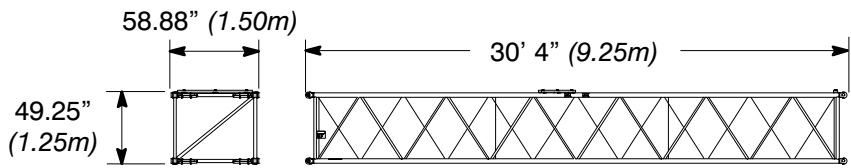

# Hook Balls

## 15 Ton (13.6mt) Swivel

### Hook Ball\* ①

Width	21.62 in	(0.55m)
Height	40.54 in	(1.03m)
Weight	1,211 lb	(549kg)

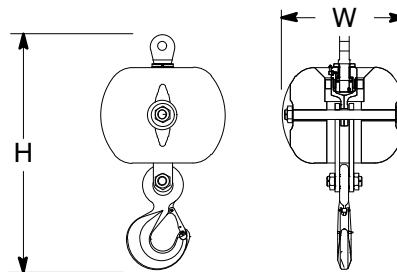

## 15 Ton (13.6mt) Non-Swivel

### Hook Ball\* ①

Width	21.65 in	(0.55m)
Height	40.36 in	(1.03m)
Weight	1,192 lb	(541kg)

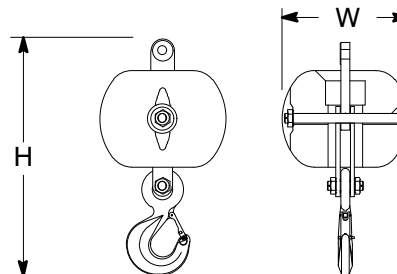

Number inside black circle "①" = # of components

\* – Optional equipment



# Hook Blocks

## 30 Ton (27.22mt)

### 1-Sheave Hook Block\* ①

Width1	21.13 in	(0.54m)
Width2	28.75 in	(0.73m)
Width3	13.34 in	(0.34m)
Height	53.92 in	(1.37m)
Weight	1,706 lb	(774kg)

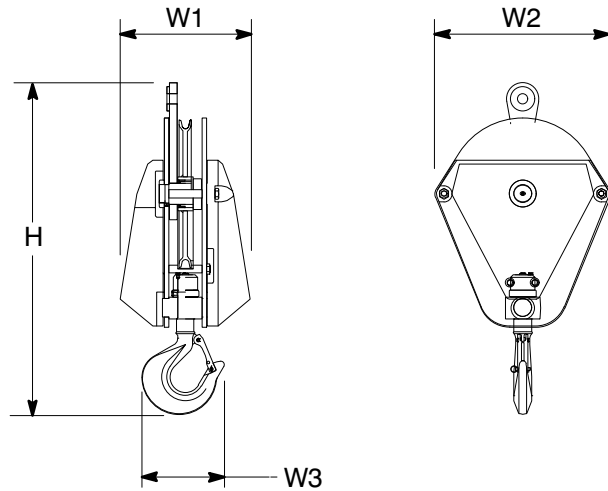

## 80 Ton (72.57mt)

### 3-Sheave Hook Block\* ①

Width1	18.89 in	(0.48m)
Width2	28.75 in	(0.73m)
Width3	20.31 in	(0.52m)
Height	69.74 in	(1.77m)
Weight	2,085 lb	(946kg)

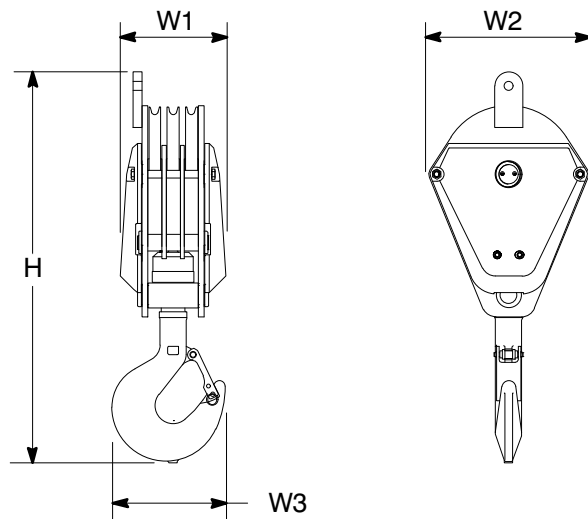

## 150 Ton (136.08mt)

### 5-Sheave Hook Block\* ①

Width1	23.90 in	(0.61m)
Width2	28.75 in	(0.73m)
Width3	28.12 in	(0.71m)
Height	80.81 in	(2.05m)
Weight	3,606 lb	(1 636kg)

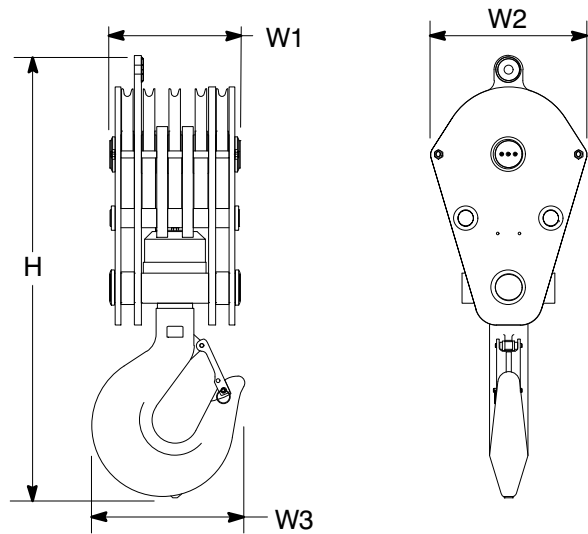

Number inside black circle “①” = # of components

\* — Optional equipment

# Working Weights

Based on basic crane including <b>Isuzu 6HK1–T4i</b> diesel engine, turntable bearing, independent hydraulic powered drums, boom hoist limiting device, independent hydraulic swing and travel, full counterweight, swing brake, drum rotation indicators, hydraulic boom foot pin removal, and crawler lower with 44 in (1.12m) wide track shoes, sealed track rollers, catwalks, plus the following:		<b>Ctwt “ABCD”</b>
		lb (kg)
Lifting crane — includes 50 ft (15.24m) basic tubular boom, 26 ft (7.92m) live mast, 880 ft (268.22m) of 26mm diameter wire rope, 580 ft (176.78m) of 7/8 in (22mm) diameter boom hoist rope, 150 Ton (136.1mt) hook block, and basic pendants.		262,677 (119 148)
Ground Bearing Pressure	psi	10.51
	kg/cm <sup>2</sup>	0.74

# Transport Weights

Base Crane: Rigid boom backstops, 50 gal (189L) of fuel, catwalks (both sides), 26 ft (7.92m) live mast, bail, boom hoist rope, boom base section, 10 ft (3.05m) self-assembly section, 880 ft (268.22m) of type “ZB” front hoist rope, and 880 ft (268.22m) of type “ZB” rear hoist rope.

Item Description	Gross Weight		Transport Loads						
	lb	(kg)	#1	#2	#3	#4	#5	#6	#7
Base Crane	87,000	39 463	1						
Add Side Frame — Two Required	32,850	14 900		1	1				
Add “A” Base Counterweight	20,000	9 072					1		
Add “B” Wing Counterweight — Right Side	14,200	6 441				1			
Add “B” Wing Counterweight — Left Side	15,000	6 804				1			
Add “C” Wing Counterweight — Right Side	14,200	6 441						1	
Add “C” Wing Counterweight — Left Side	15,000	6 804						1	
Add “D” Wing Counterweight — Right Side	14,200	6 441							1
Add “D” Wing Counterweight — Left Side	15,000	6 804							1
Add Hydraulic Third Drum without Rope	1,962	890							
Add 30 ft (9.14m) Top Section	4,250	1 928							1
Add 10 ft (3.05m) Extension w/Pins and Pendants	1,032	468							1
Add 20 ft (6.10m) Extension w/Pins and Pendants	1,656	751					1	1	
Add 30 ft (9.14m) Extension w/Pins and Pendants	2,284	1 036						1	
Add 40 ft (12.19m) Extension w/Pins and Pendants	2,908	1 319		1	1	1			
Add 30 ft (9.14m) Jib	2,328	1 056					1		
Add 10 ft (3.05m) Jib Extension w/Pins and Pendants	226	103						1	
Add 20 ft (6.10m) Jib Extension w/Pins and Pendants	396	180				2			
Add Auxiliary Tip Extension	736	334							
Add 15 Ton (13.6mt) Hook Ball (Non–swivel)	1,192	541			1				
Add 15 Ton (13.6mt) Hook Ball (Swivel)	1,211	549							
Add 150 Ton (136.0mt) 5–Sheave Hook Block	3,606	1 636		1					
Remove 10 ft (3.05m) Self-Assembly Section	–3,230	–1 465							
Remove 20 ft (6.10m) Base Section	–2,965	–1 345							
Remove Front Drum Wire Rope	–1,874	–850							
Remove 50 gal (189L) of Fuel	–362	–164							
<b>Approximate Total Shipping Weight</b>	<b>lb</b>	<b>87,000</b>	<b>39,364</b>	<b>36,950</b>	<b>32,900</b>	<b>23,984</b>	<b>33,366</b>	<b>34,482</b>	
	<b>kg</b>	<b>39 463</b>	<b>17 856</b>	<b>16 761</b>	<b>14 923</b>	<b>10 879</b>	<b>15 135</b>	<b>15 641</b>	

## Notes:

Estimated weights vary by +/- 2%. Numbers in the load columns (numbers 1 – 7) represent quantities.

Estimated transport loads assume the load out consist of 240 ft (73.15m) of boom and 80 ft (24.38m) of jib and full counterweight.

Support loads were targeted at 45,000 lb (20 412kg), 8.5 ft (2.59m) wide, and 48 ft (14.63m) long trailer. This may vary depending on state laws, empty truck/trailer weights, and style of trailer.

# Transport Drawings

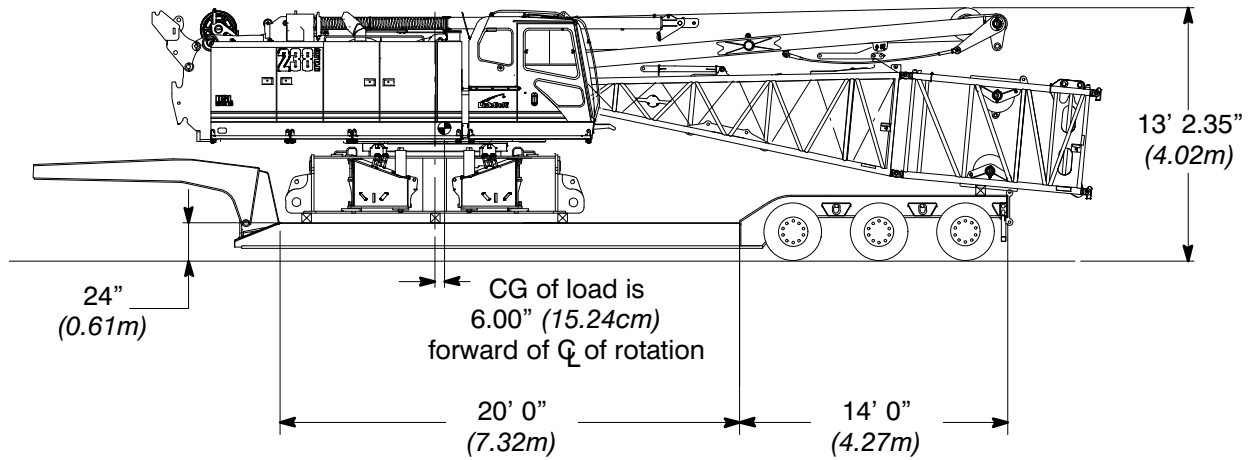

**Load #1 Total 87,000 (39 463kg)**  
Base Crane

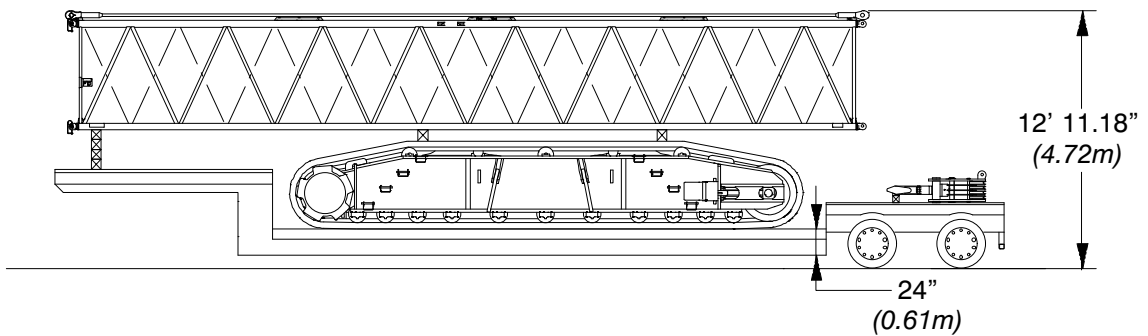

**Load #2 Total 39,364 (17 856kg)**  
Side frame, 40 ft (12.19m) boom extension, and 150 Ton (136mt) hook block

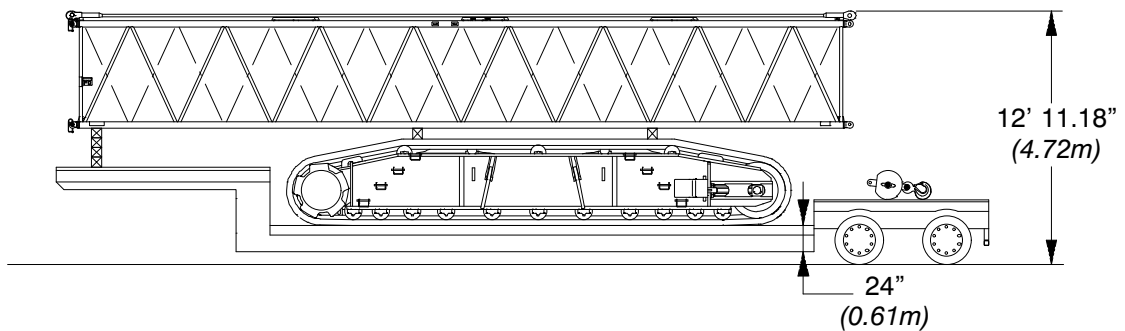

**Load #3 Total 36,950 (16 761kg)**  
Side frame, 40 ft (12.19m) boom extension, and 15 Ton (13.6mt) hook ball

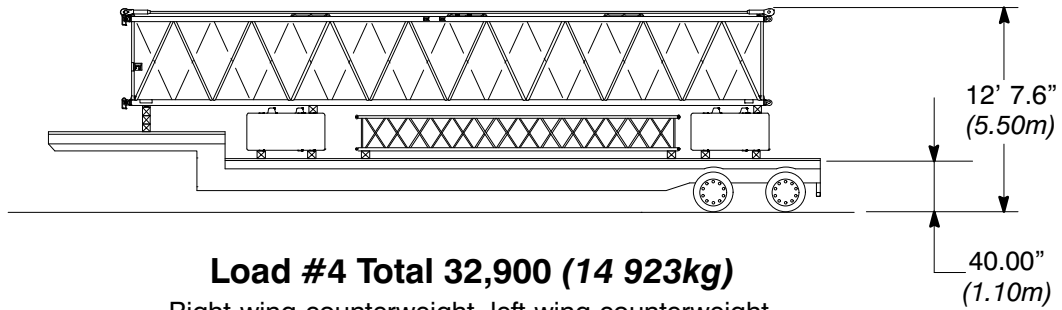

**Load #4 Total 32,900 (14 923kg)**

Right wing counterweight, left wing counterweight,  
40 ft (12.19m) boom extension, and two 20 ft (6.09m) fixed jib extensions

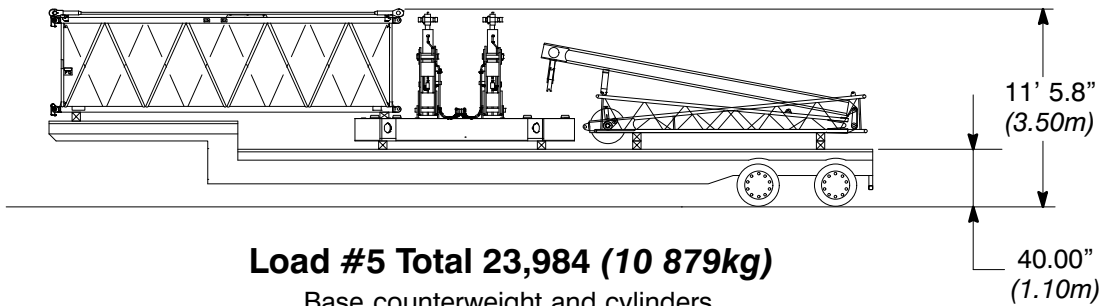

**Load #5 Total 23,984 (10 879kg)**

Base counterweight and cylinders,  
20 ft (6.10m) boom extension with pins and pendants, and 30 ft (4.57m) jib

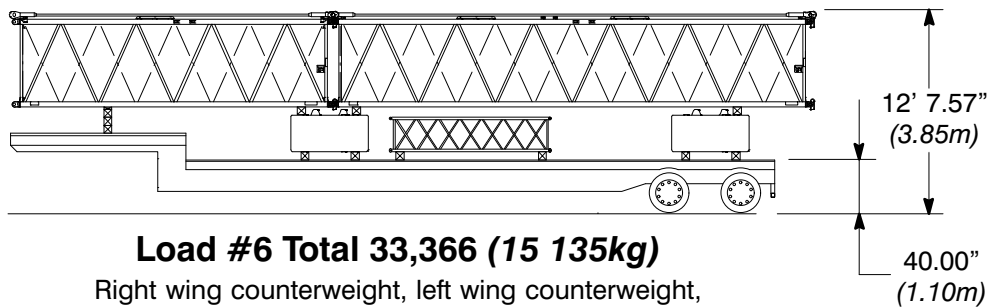

**Load #6 Total 33,366 (15 135kg)**

Right wing counterweight, left wing counterweight,  
20 ft (6.10m) boom extension with pins and pendants, 30 ft (4.57m) boom extension,  
and 10 ft (3.05m) fixed jib extension

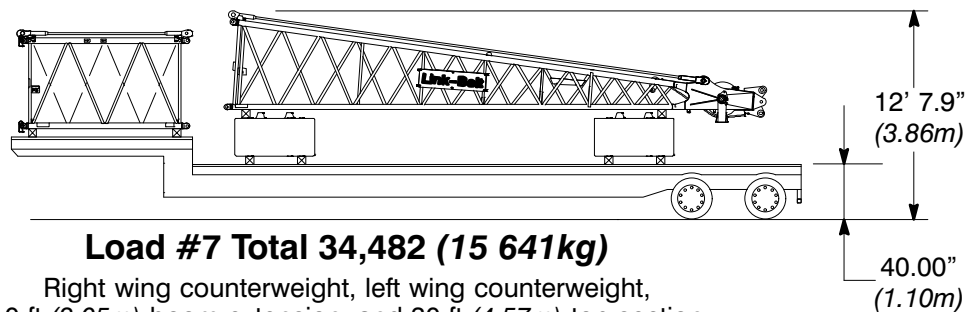

**Load #7 Total 34,482 (15 641kg)**

Right wing counterweight, left wing counterweight,  
10 ft (3.05m) boom extension, and 30 ft (4.57m) top section

# Load Hoist Performance

## Front And Rear Drum – 26mm Wire Rope

Rope Layer	Maximum Line Pull		No Load Line Speed		Full Load Line Speed		Pitch Diameter		Layer		Total	
	lb	kg	ft/min	m/min	ft/min	m/min	in	mm	ft	m	ft	m
1	46,924	21,285	364	111	136	41	22.8	580	137.5	41.9	137.5	41.9
2	43,597	19,776	391	119	137	42	24.9	632	148.0	45.1	285.5	87.0
3	40,711	18,466	419	128	138	42	26.9	684	158.5	48.3	444.0	135.3
4	38,183	17,320	447	136	135	41	29.0	736	169.0	51.5	612.9	186.8
5	35,951	16,307	475	145	107	33	31.0	788	179.5	54.7	792.4	241.5
6	33,965	15,406	502	153	58	18	33.1	840	190.0	57.9	982.4	299.4

## Boom Hoist Drum – 7/8 in (22mm) Wire Rope

Rope Layer	Maximum Line Pull		No Load Line Speed		Pitch Diameter		Layer		Total	
	lb	kg	ft/min	m/min	in	mm	ft	m	ft	m
1	46,922	21,284	142	43	21.8	553	68.4	20.8	68.4	20.8
2	43,896	19,911	152	46	23.5	598	73.1	22.3	141.5	43.1
3	41,236	18,704	162	49	25.3	643	77.8	23.7	219.3	66.9
4	38,880	17,636	171	52	27.1	687	82.5	25.2	301.9	92.0
5	36,779	16,683	181	55	28.8	732	87.3	26.6	389.1	118.6
6	34,893	15,827	191	58	30.6	777	92.0	28.0	481.1	146.6
7	33,191	15,055	201	61	32.4	822	96.7	29.5	577.8	176.1

## Third Drum – 7/8 in (22mm) Wire Rope

Rope Layer	Maximum Line Pull		No Load Line Speed		Full Load Line Speed		Pitch Diameter		Layer		Total	
	lb	kg	ft/min	m/min	ft/min	m/min	in	mm	ft	m	ft	m
1	20,555	9 324	272	82.9	242	73.8	20.5	521	134	40.8	134	40.8
2	18,933	8 588	295	89.9	263	80.2	22.2	564	145	44.2	279	85.0
3	17,552	7 962	318	96.9	284	86.6	24.0	610	156	47.5	435	132.6
4	16,359	7 420	341	103.9	304	92.7	25.7	653	168	51.2	603	183.8
5	15,318	6 948	365	111.3	325	99.1	27.5	699	179	54.6	782	238.4

Wire Rope Application	Diameter		Type	Max. Permissible Load		Wire Rope Descriptions
	in	mm		lb	kg	
Boom Hoist	7/8	22	LB	25,029	11 353	6 Strand, Compacted Strand, Swaged, Preformed, I.W.R.C., Right Lay, Regular Lay
Front Hoist	1.02	26	ZB	29,200	13 245	34 X 7 Rotation Resistant – Extra Improved Plow Steel – Right Regular Lay or Right Lang Lay
Third Drum (Optional)	7/8	22	RB	17,520	7 947	19 X 19 Rotation Resistant Compacted Strand – High Strength – Preformed, Right Regular Lay
Rear Drum	1.02	26	ZB	29,200	13 245	34 X 7 Rotation Resistant – Extra Improved Plow Steel – Right Regular Lay or Right Lang Lay

# Working Areas

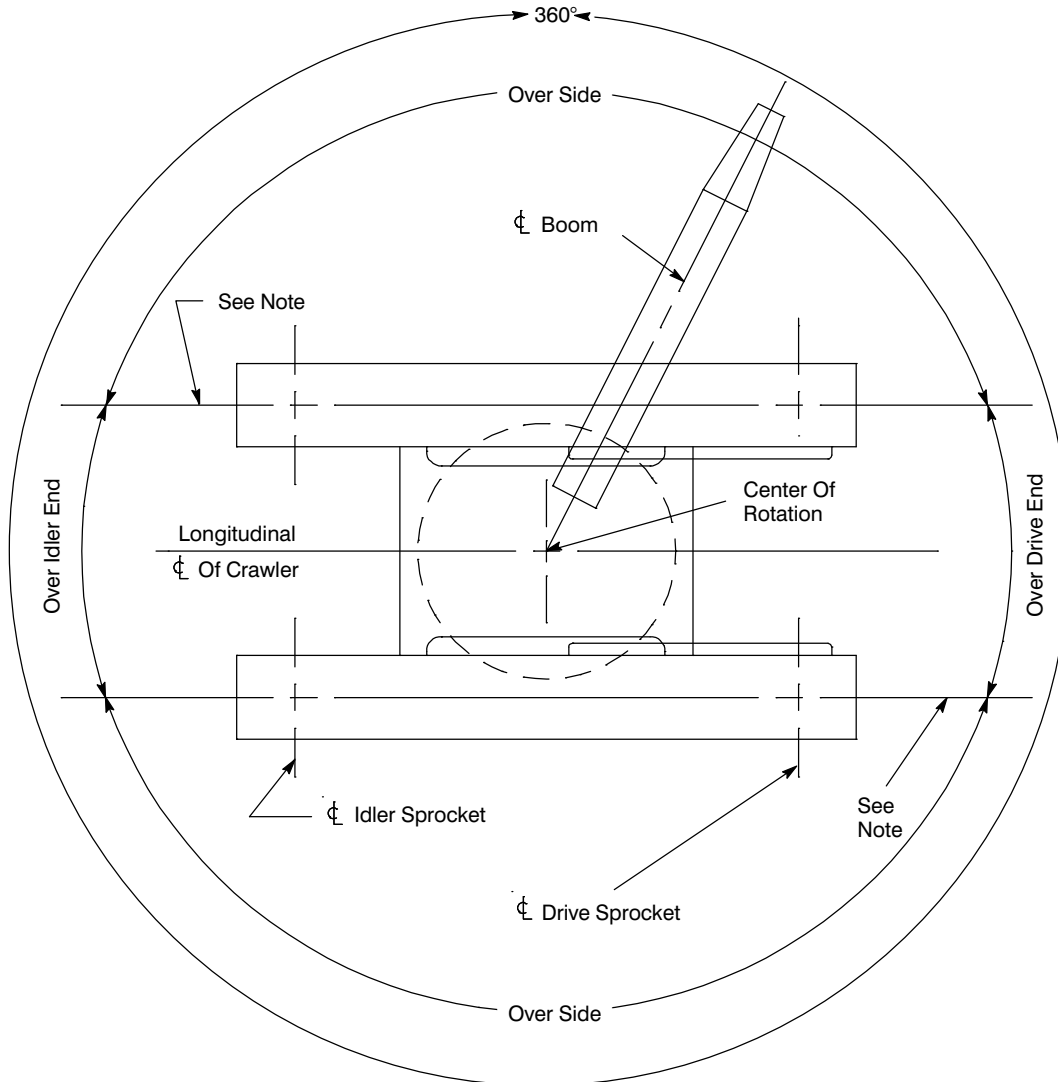

**Note:** These Lines Determine The Limiting Position Of Any Load For Operation Within Working Areas Indicated.

# Attachments

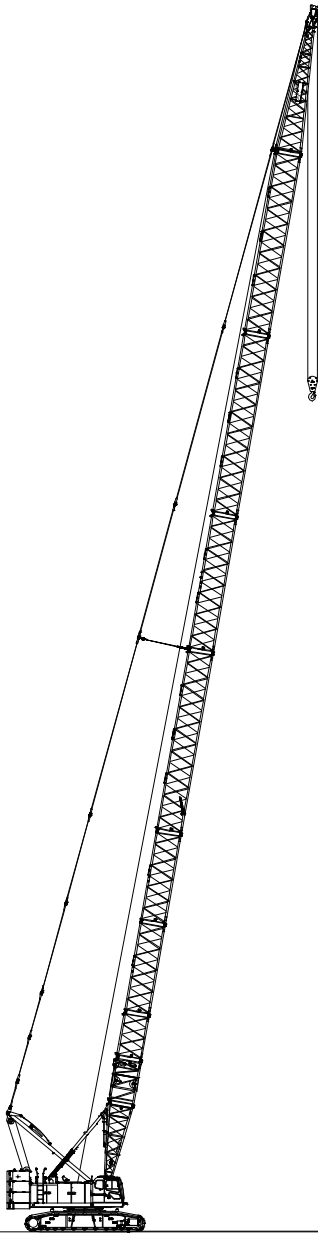

**50–260 ft (15.24–79.25m)  
Main Boom**

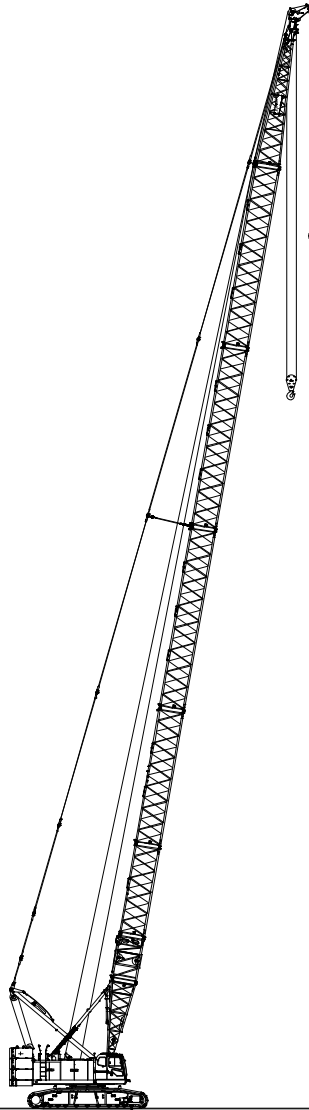

**50–230 ft (15.24–70.10m)  
Main Boom With Tip Extension**

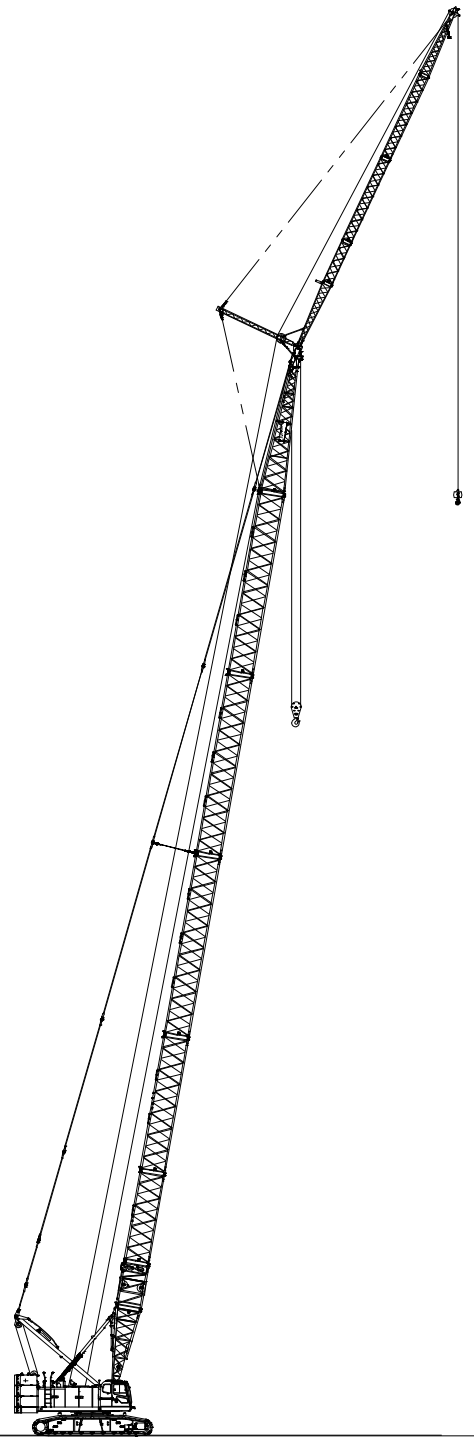

**50–230 ft (15.24–70.10m)  
Main Boom With  
30–80 ft (9.14–24.38m) Jib**

# Main Boom Make-up

Boom Length ft (m)	Boom Extensions ft (m)				
	Self Assy Section*	10 (3.05)	20 (6.14)	30 (9.10)	40 (12.19)
60 (18.29)	1				
70 (21.34)	1	1			
80 (24.38)	1		1		
90 (27.43)	1			1	
100 (30.48)	1				1
110 (33.53)	1	1			1
120 (36.58)	1		1		1
130 (39.62)	1			1	1
140 (42.67)	1				2
150 (45.72)	1	1			2
160 (48.77)	1		1		2
170 (51.82)	1			1	2
180 (54.86)	1				3
190 (57.91)	1	1			3
200 (60.96)	1		1		3
210 (64.01)	1			1	3
220 (67.06)	1	1		1	3
230 (70.10)	1		1	1	3
240 (73.15)	1	1	1	1	3
250 (76.20)	1		2	1	3
260 (79.25)	1	1	2	1	3

\* 10 ft (3.05m) self assembly section.

## Optional Auxiliary Tip Extension

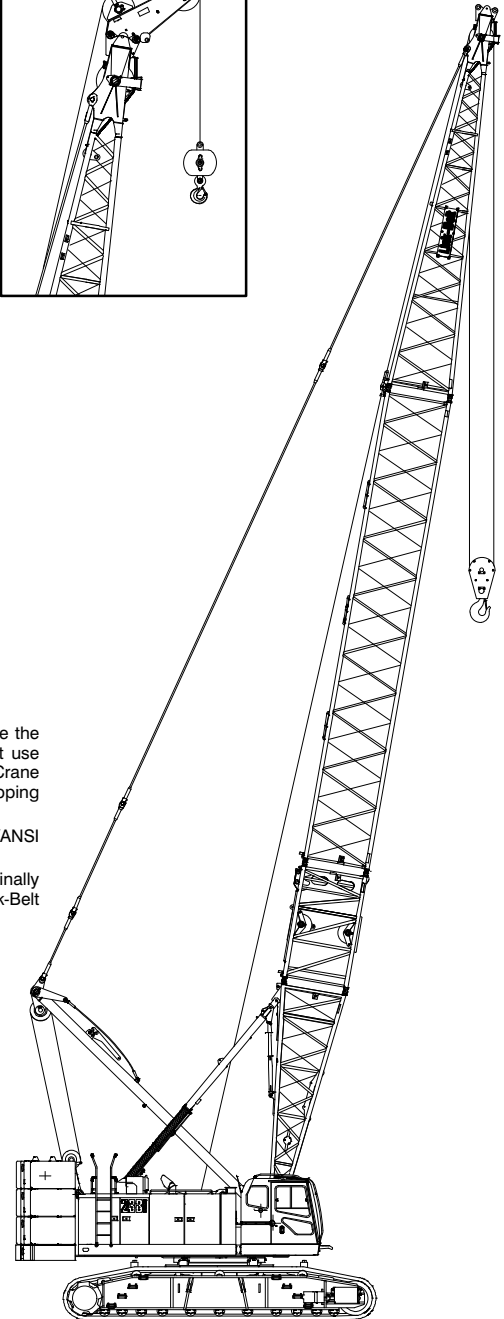
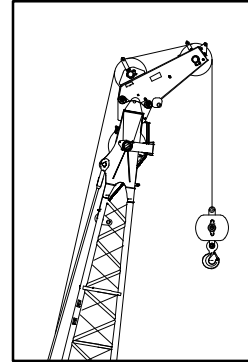

## Notes:

- Capacities shown are in kips/metric tons (1 kip = 1,000 lb / 1 metric ton = 0.45 kips) and are not more than 75% of the tipping loads with the crane standing level on firm supporting surface. A deduction must be made from these capacities for weight of hook block, hook ball, sling, grapple, load weighing device, etc. When using main hook while jib or tip extension is attached, reduce capacities by values shown in Crane Rating Manual. See Operator's Manual for all limitations when raising or lowering attachment.
- The capacities in the shaded areas are based on structural strength. The capacities in the non-shaded areas are based on stability ratings.
- For recommended reeving, parts of line, wire rope type, and wire rope inspection, see Wire Rope Capacity Chart, Operator's Manual, and Parts Manual.
- Load ratings are based on freely suspended loads and make no allowances for such factors as the effect of the wind, ground conditions, and operating speeds. The operator shall therefore reduce load ratings in order to take these conditions into account. Refer to the Crane Rating Manual for Wind Speed Restrictions.
- The 26 ft (7.92m) live mast must be used for all capacities listed.
- The least stable rated condition is over the side.
- Booms must be erected and lowered over the end for maximum stability.
- Main boom length must not exceed 260 ft (79.25m).
- Do not operate at radii and boom lengths where the Crane Rating Manual lists no capacity. Do not use longer booms or jibs than those listed in the Crane Rating Manual. Any of the above can cause a tipping condition, or boom and jib failure.
- These capacities are in compliance with ASME/ANSI B30.5 at date of manufacture.
- These capacities apply only to the crane as originally manufactured and normally equipped by Link-Belt Construction Equipment Company.



# Main Boom Working Range Diagram

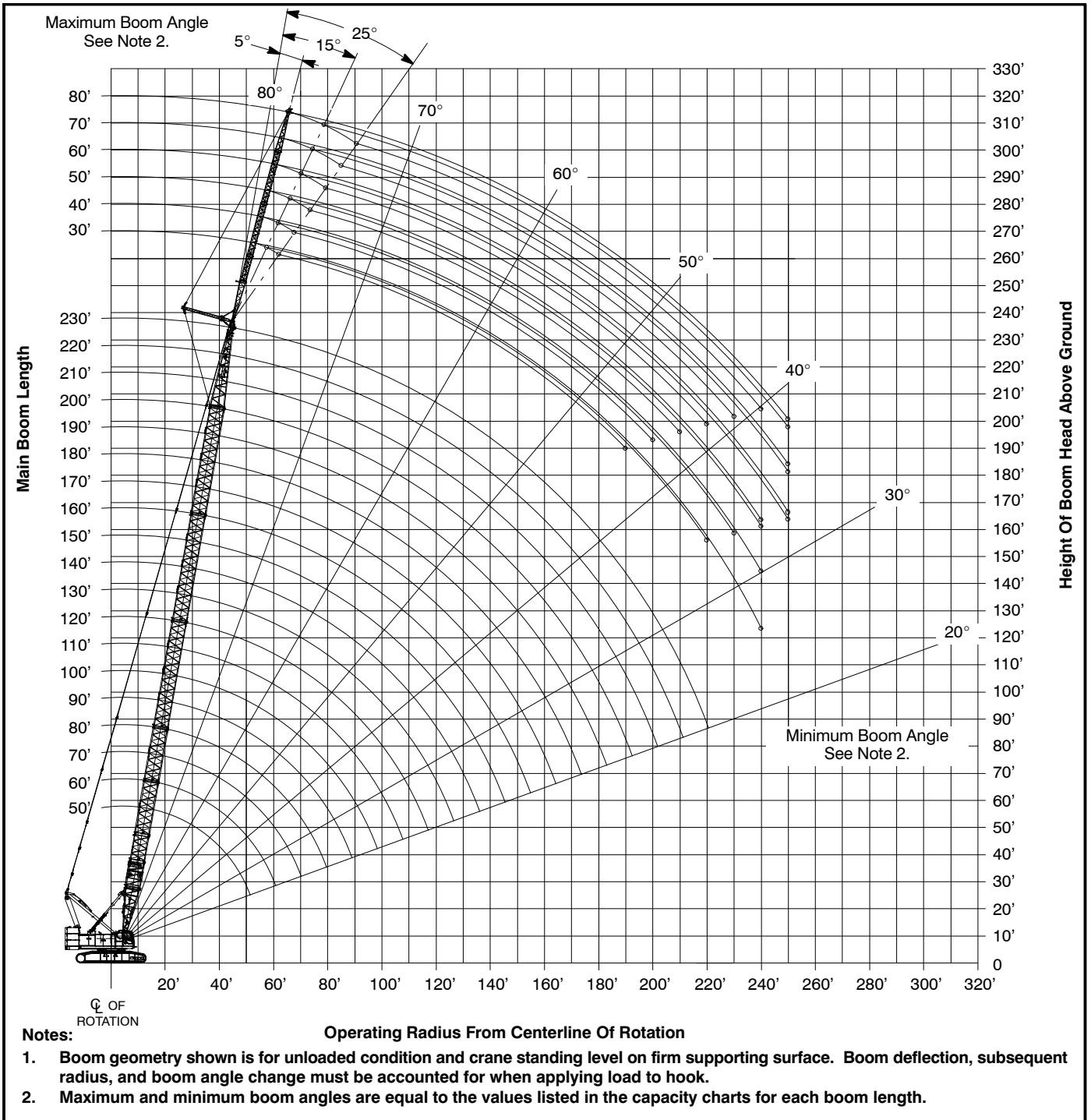

# Main Boom Load Charts

Main Boom Lift Capacity Chart – 360° Rotation ABCD = 107,600 lb (48 807kg) Counterweight [All capacities are listed in kips (mt)]												
Load Radius ft (m)	Boom Length - ft (m)											Load Radius ft (m)
	50 (15.2)	60 (18.3)	70 (21.3)	80 (24.4)	90 (27.4)	100 (30.5)	110 (33.5)	120 (36.6)	130 (39.6)	140 (42.7)	150 (45.7)	
14 (4.3)	300.0 (136.1)											14 (4.3)
15 (4.6)	287.7 (130.5)	273.4 (124.0)										15 (4.6)
16 (4.9)	271.0 (122.9)	269.1 (122.1)										16 (4.9)
17 (5.2)	256.2 (116.2)	254.1 (115.3)	240.4 (109.0)									17 (5.2)
18 (5.5)	242.8 (110.1)	240.8 (109.2)	236.6 (107.3)									18 (5.5)
19 (5.8)	230.7 (104.6)	228.8 (103.8)	228.1 (103.5)	213.9 (97.0)								19 (5.8)
20 (6.1)	219.8 (99.7)	218.1 (98.9)	217.4 (98.6)	210.6 (95.5)								20 (6.1)
25 (7.6)	177.4 (80.5)	175.9 (79.8)	175.5 (79.6)	175.0 (79.4)	174.4 (79.1)	167.7 (76.1)	155.2 (70.4)					25 (7.6)
30 (9.1)	138.9 (63.0)	138.5 (62.8)	138.6 (62.9)	138.6 (62.9)	138.5 (62.8)	138.3 (62.7)	138.2 (62.7)	136.6 (62.0)	126.2 (57.2)	117.6 (53.3)		30 (9.1)
35 (10.7)	111.2 (50.4)	110.7 (50.2)	110.8 (50.3)	110.8 (50.3)	110.7 (50.2)	110.5 (50.1)	110.4 (50.1)	110.2 (50.0)	110.0 (49.9)	109.8 (49.8)	104.7 (47.5)	35 (10.7)
40 (12.2)	92.5 (42.0)	92.0 (41.7)	92.0 (41.7)	92.0 (41.7)	91.9 (41.7)	91.8 (41.6)	91.6 (41.5)	91.4 (41.5)	91.2 (41.4)	91.0 (41.3)	90.8 (41.2)	40 (12.2)
50 (15.2)	68.6 (31.1)	68.0 (30.8)	68.1 (30.9)	68.1 (30.9)	67.9 (30.8)	67.8 (30.8)	67.6 (30.7)	67.4 (30.6)	67.1 (30.4)	66.9 (30.3)	66.7 (30.3)	50 (15.2)
60 (18.3)		53.5 (24.3)	53.7 (24.4)	53.6 (24.3)	53.5 (24.3)	53.4 (24.2)	53.2 (24.1)	53.0 (24.0)	52.8 (23.9)	52.6 (23.9)	52.3 (23.7)	60 (18.3)
70 (21.3)			43.8 (19.9)	43.8 (19.9)	43.7 (19.8)	43.6 (19.8)	43.4 (19.7)	43.2 (19.6)	43.0 (19.5)	42.7 (19.4)	42.5 (19.3)	70 (21.3)
80 (24.4)					36.7 (16.6)	36.6 (16.6)	36.4 (16.5)	36.1 (16.4)	35.9 (16.3)	35.7 (16.2)	35.4 (16.1)	80 (24.4)
90 (27.4)						31.4 (14.2)	31.2 (14.2)	31.0 (14.1)	30.8 (14.0)	30.6 (13.9)	30.4 (13.8)	90 (27.4)
100 (30.5)							27.1 (12.3)	26.9 (12.2)	26.7 (12.1)	26.5 (12.0)	26.2 (11.9)	100 (30.5)
110 (33.5)								23.5 (10.7)	23.3 (10.6)	23.1 (10.5)	22.9 (10.4)	110 (33.5)
120 (36.6)									20.6 (9.3)	20.4 (9.3)	20.1 (9.1)	120 (36.6)
130 (39.6)										18.1 (8.2)	17.9 (8.1)	130 (39.6)
140 (42.7)											15.9 (7.2)	140 (42.7)

This material is supplied for reference use only. Operator must refer to in-cab Crane Rating Manual and Operator's Manual to determine allowable crane lifting capacities and assembly and operating procedures.

**Main Boom Lift Capacity Chart – 360° Rotation**  
**ABCD = 107,600 lb (48 807kg) Counterweight**  
 [All capacities are listed in kips (mt)]

Load Radius ft (m)	Boom Length ft (m)											Load Radius ft (m)
	160 (48.8)	170 (51.8)	180 (54.9)	190 (57.9)	200 (61.0)	210 (64.0)	220 (57.9)	230 (61.0)	240 (64.0)	250 (61.0)	260 (64.0)	
35 (10.7)	97.8 (44.4)	90.2 (40.9)										35 (10.7)
40 (12.2)	90.6 (41.1)	86.2 (39.1)	79.6 (36.1)	70.7 (32.1)	62.5 (28.3)							40 (12.2)
50 (15.2)	66.4 (30.1)	66.1 (30.0)	65.9 (29.9)	65.6 (29.8)	60.1 (27.3)	53.4 (24.2)	47.5 (21.5)	42.7 (19.4)	38.4 (17.4)	34.3 (15.6)	30.3 (13.7)	50 (15.2)
60 (18.3)	52.1 (23.6)	51.8 (23.5)	51.5 (23.4)	51.3 (23.3)	51.0 (23.1)	48.3 (21.9)	43.3 (19.6)	38.6 (17.5)	34.5 (15.6)	30.4 (13.8)	27.4 (12.4)	60 (18.3)
70 (21.3)	42.2 (19.1)	41.9 (19.0)	41.7 (18.9)	41.4 (18.8)	41.1 (18.6)	40.8 (18.5)	38.9 (17.6)	34.7 (15.7)	30.5 (13.8)	27.3 (12.4)	24.6 (11.2)	70 (21.3)
80 (24.4)	35.1 (15.9)	34.9 (15.8)	34.6 (15.7)	34.3 (15.6)	34.0 (15.4)	33.7 (15.3)	33.4 (15.1)	30.7 (13.9)	27.4 (12.4)	24.7 (11.2)	22.1 (10.0)	80 (24.4)
90 (27.4)	30.1 (13.7)	29.9 (13.6)	29.6 (13.4)	29.3 (13.3)	29.1 (13.2)	28.8 (13.1)	28.5 (12.9)	27.8 (12.6)	24.6 (11.2)	22.2 (10.1)	19.8 (9.0)	90 (27.4)
100 (30.5)	26.0 (11.8)	25.7 (11.7)	25.4 (11.5)	25.2 (11.4)	24.9 (11.3)	24.6 (11.2)	24.3 (11.0)	23.9 (10.8)	22.5 (10.2)	19.9 (9.0)	17.8 (8.1)	100 (30.5)
110 (33.5)	22.6 (10.3)	22.4 (10.2)	22.1 (10.0)	21.8 (9.9)	21.6 (9.8)	21.3 (9.7)	21.0 (9.5)	20.6 (9.3)	20.2 (9.2)	17.9 (8.1)	16.0 (7.3)	110 (33.5)
120 (36.6)	19.9 (9.0)	19.6 (8.9)	19.4 (8.8)	19.1 (8.7)	18.8 (8.5)	18.5 (8.4)	18.2 (8.3)	17.8 (8.1)	17.5 (7.9)	16.3 (7.4)	14.5 (6.6)	120 (36.6)
130 (39.6)	17.6 (8.0)	17.4 (7.9)	17.1 (7.8)	16.8 (7.6)	16.5 (7.5)	16.2 (7.3)	16.0 (7.3)	15.5 (7.0)	15.2 (6.9)	14.8 (6.7)	13.0 (5.9)	130 (39.6)
140 (42.7)	15.7 (7.1)	15.4 (7.0)	15.1 (6.8)	14.9 (6.8)	14.6 (6.6)	14.3 (6.5)	14.0 (6.4)	13.5 (6.1)	13.3 (6.0)	13.0 (5.9)	11.9 (5.4)	140 (42.7)
150 (45.7)	14.0 (6.4)	13.8 (6.3)	13.5 (6.1)	13.2 (6.0)	12.9 (5.9)	12.6 (5.7)	12.4 (5.6)	11.9 (5.4)	11.6 (5.3)	11.3 (5.1)	10.8 (4.9)	150 (45.7)
160 (48.8)		12.3 (5.6)	12.1 (5.5)	11.8 (5.4)	11.5 (5.2)	11.2 (5.1)	10.9 (4.9)	10.4 (4.7)	10.1 (4.6)	9.9 (4.5)	9.6 (4.4)	160 (48.8)
170 (51.8)			10.8 (4.9)	10.5 (4.8)	10.2 (4.6)	9.9 (4.5)	9.7 (4.4)	9.2 (4.2)	8.9 (4.0)	8.6 (3.9)	8.3 (3.8)	170 (51.8)
180 (54.9)				9.4 (4.3)	9.1 (4.1)	8.8 (4.0)	8.5 (3.9)	8.0 (3.6)	7.8 (3.5)	7.5 (3.4)	7.2 (3.3)	180 (54.9)
190 (57.9)					8.1 (3.7)	7.8 (3.5)	7.4 (3.4)	7.1 (3.2)	6.8 (3.1)	6.5 (2.9)	6.2 (2.8)	190 (57.9)
200 (61.0)						6.7 (3.0)	6.3 (2.9)	6.2 (2.8)	5.9 (2.7)	5.6 (2.5)	5.3 (2.4)	200 (61.0)
210 (64.0)							5.3 (2.4)	5.4 (2.4)	5.1 (2.3)	4.8 (2.2)	4.5 (2.0)	210 (64.0)
220 (67.1)								4.7 (2.1)	4.4 (2.0)	4.1 (1.9)	3.8 (1.7)	220 (67.1)
230 (70.1)										3.4 (1.5)	3.1 (1.4)	230 (70.1)

This material is supplied for reference use only. Operator must refer to in-cab Crane Rating Manual and Operator's Manual to determine allowable crane lifting capacities and assembly and operating procedures.

**Tubular Main Boom + 30 ft (9.14m) Offset Tube Jib -- 360° Rotation**  
**ABCD = 107,600 lb (48 807kg) Counterweight**  
**[All capacities are listed in kips (mt)]**

Load Radius ft (m)	5° Offset					Load Radius ft (m)	15° Offset					Load Radius ft (m)	25° Offset				
	Boom Length – ft (m)						Boom Length – ft (m)						Boom Length – ft (m)				
	50 (15.2)	90 (27.4)	140 (42.7)	190 (57.9)	230 (70.1)		50 (15.2)	90 (27.4)	140 (42.7)	190 (57.9)	230 (70.1)		50 (15.2)	90 (27.4)	140 (42.7)	190 (57.9)	230 (70.1)
25 (7.6)	58.4 (26.5)					25 (7.6)						25 (7.6)					
30 (9.1)	58.4 (26.5)	58.4 (26.5)				30 (9.1)	57.0 (25.9)					30 (9.1)					
35 (10.7)	58.3 (26.4)	58.4 (26.5)				35 (10.7)	55.6 (25.2)	56.3 (25.5)				35 (10.7)	42.7 (19.4)				
40 (12.2)	56.7 (25.7)	58.4 (26.5)	56.5 (25.6)			40 (12.2)	50.0 (22.7)	55.4 (25.1)				40 (12.2)	39.2 (17.8)	44.8 (20.3)			
50 (15.2)	48.1 (21.8)	56.5 (25.6)	55.0 (24.9)	38.9 (17.6)		50 (15.2)	41.3 (18.7)	52.8 (23.9)	52.2 (23.7)			50 (15.2)	33.8 (15.3)	39.8 (18.1)	44.4 (20.1)		
60 (18.3)	39.6 (18.0)	54.1 (24.5)	52.8 (23.9)	37.9 (17.2)	24.0 (10.9)	60 (18.3)	35.4 (16.1)	45.9 (20.8)	51.2 (23.2)	36.6 (16.6)		60 (18.3)	32.0 (14.5)	35.9 (16.3)	40.8 (18.5)	33.9 (15.4)	
70 (21.3)	33.8 (15.3)	44.3 (20.1)	42.9 (19.5)	36.9 (16.7)	23.3 (10.6)	70 (21.3)	32.1 (14.6)	40.7 (18.5)	43.3 (19.6)	35.5 (16.1)	23.3 (10.6)	70 (21.3)		32.9 (14.9)	37.8 (17.1)	32.9 (14.9)	19.3 (8.8)
80 (24.4)	32.1 (14.6)	37.3 (16.9)	35.8 (16.2)	34.4 (15.6)	22.6 (10.3)	80 (24.4)		36.7 (16.6)	36.1 (16.4)	34.5 (15.6)	22.6 (10.3)	80 (24.4)		32.0 (14.5)	35.3 (16.0)	30.0 (13.6)	18.6 (8.4)
90 (27.4)		31.9 (14.5)	30.8 (14.0)	29.4 (13.3)	21.9 (9.9)	90 (27.4)		31.9 (14.5)	31.0 (14.1)	29.7 (13.5)	21.8 (9.9)	90 (27.4)		31.1 (14.1)	31.3 (14.2)	29.3 (13.3)	18.0 (8.2)
100 (30.5)		28.0 (12.7)	26.6 (12.1)	25.2 (11.4)	21.2 (9.6)	100 (30.5)		27.9 (12.7)	26.7 (12.1)	25.5 (11.6)	21.1 (9.6)	100 (30.5)			27.0 (12.2)	25.8 (11.7)	17.5 (7.9)
110 (33.5)		24.6 (11.2)	23.3 (10.6)	21.8 (9.9)	20.6 (9.3)	110 (33.5)			23.3 (10.6)	22.1 (10.0)	20.5 (9.3)	110 (33.5)			23.5 (10.7)	22.3 (10.1)	17.0 (7.7)
120 (36.6)			20.5 (9.3)	19.1 (8.7)	17.8 (8.1)	120 (36.6)			20.6 (9.3)	19.3 (8.8)	19.9 (9.0)	120 (36.6)			20.7 (9.4)	19.5 (8.8)	16.5 (7.5)
130 (39.6)			18.2 (8.3)	16.8 (7.6)	15.5 (7.0)	130 (39.6)			18.2 (8.3)	16.9 (7.7)	18.2 (8.3)	130 (39.6)			18.4 (8.3)	17.1 (7.8)	16.1 (7.3)
140 (42.7)			16.3 (7.4)	14.8 (6.7)	13.5 (6.1)	140 (42.7)			16.3 (7.4)	14.9 (6.8)	15.8 (7.2)	140 (42.7)				15.1 (6.8)	14.5 (6.6)
150 (45.7)			14.6 (6.6)	13.2 (6.0)	11.9 (5.4)	150 (45.7)				13.2 (6.0)	13.8 (6.3)	150 (45.7)				13.4 (6.1)	12.7 (5.8)
160 (48.8)			13.2 (6.0)	11.5 (5.2)	10.2 (4.6)	160 (48.8)				11.5 (5.2)	12.1 (5.5)	160 (48.8)				11.7 (5.3)	11.2 (5.1)
170 (51.8)				10.0 (4.5)	8.8 (4.0)	170 (51.8)				10.0 (4.5)	10.5 (4.8)	170 (51.8)					9.6 (4.4)
180 (54.9)				8.7 (3.9)	7.5 (3.4)	180 (54.9)				8.7 (3.9)	9.0 (4.1)	180 (54.9)					8.3 (3.8)
190 (57.9)				7.6 (3.4)	6.3 (2.9)	190 (57.9)				7.5 (3.4)	7.7 (3.5)	190 (57.9)					7.1 (3.2)
200 (61.0)				6.5 (2.9)	5.3 (2.4)	200 (61.0)					6.5 (2.9)	200 (61.0)					6.0 (2.7)
210 (64.0)					4.4 (2.0)	210 (64.0)					5.5 (2.5)	210 (64.0)					
220 (67.1)					3.5 (1.6)	220 (67.1)					4.5 (2.0)	220 (67.1)					
230 (70.1)					2.7 (1.2)	230 (70.1)					3.6 (1.6)	230 (70.1)					
240 (73.2)					2.0 (0.9)	240 (73.2)						240 (73.2)					

This material is supplied for reference use only. Operator must refer to in-cab Crane Rating Manual and Operator’s Manual to determine allowable crane lifting capacities and assembly and operating procedures.

<b>Tubular Main Boom + 60 ft (18.28m) Offset Tube Jib -- 360° Rotation</b> <b>ABCD = 107,600 lb (48 807kg) Counterweight</b> <b>[All capacities are listed in kips (mt)]</b>																	
Load Radius ft (m)	5° Offset					Load Radius ft (m)	15° Offset					Load Radius ft (m)	25° Offset				
	Boom Length – ft (m)						Boom Length – ft (m)						Boom Length – ft (m)				
	50 (15.2)	90 (27.4)	140 (42.7)	190 (57.9)	230 (70.1)		50 (15.2)	90 (27.4)	140 (42.7)	190 (57.9)	230 (70.1)		50 (15.2)	90 (27.4)	140 (42.7)	190 (57.9)	230 (70.1)
30 (9.1)	31.3 (14.2)					30 (9.1)						30 (9.1)					
35 (10.7)	30.4 (13.8)					35 (10.7)						35 (10.7)					
40 (12.2)	29.5 (13.4)	30.0 (13.6)				40 (12.2)	28.0 (12.7)					40 (12.2)					
50 (15.2)	27.9 (12.7)	28.8 (13.1)	28.2 (12.8)	25.4 (11.5)		50 (15.2)	26.6 (12.1)	27.1 (12.3)				50 (15.2)	23.3 (10.6)				
60 (18.3)	26.5 (12.0)	27.7 (12.6)	27.5 (12.5)	24.8 (11.2)		60 (18.3)	24.6 (11.2)	26.2 (11.9)	25.8 (11.7)			60 (18.3)	20.3 (9.2)	22.7 (10.3)			
70 (21.3)	23.9 (10.8)	26.7 (12.1)	26.7 (12.1)	24.3 (11.0)	18.4 (8.3)	70 (21.3)	21.4 (9.7)	25.3 (11.5)	25.2 (11.4)	22.9 (10.4)		70 (21.3)	18.0 (8.2)	20.5 (9.3)	22.6 (10.3)		
80 (24.4)	20.7 (9.4)	25.8 (11.7)	26.1 (11.8)	23.8 (10.8)	17.9 (8.1)	80 (24.4)	18.9 (8.6)	23.2 (10.5)	24.6 (11.2)	22.5 (10.2)	16.7 (7.6)	80 (24.4)	16.3 (7.4)	18.8 (8.5)	21.0 (9.5)	19.0 (8.6)	14.7 (6.7)
90 (27.4)	18.2 (8.3)	24.4 (11.1)	25.5 (11.6)	23.4 (10.6)	17.5 (7.9)	90 (27.4)	17.0 (7.7)	21.0 (9.5)	24.1 (10.9)	22.2 (10.1)	16.3 (7.4)	90 (27.4)	14.9 (6.8)	17.4 (7.9)	19.6 (8.9)	18.7 (8.5)	14.3 (6.5)
100 (30.5)	16.3 (7.4)	21.8 (9.9)	24.9 (11.3)	22.4 (10.2)	17.0 (7.7)	100 (30.5)	15.5 (7.0)	19.3 (8.8)	23.2 (10.5)	21.8 (9.9)	15.8 (7.2)	100 (30.5)		16.2 (7.3)	18.4 (8.3)	18.5 (8.4)	13.9 (6.3)
110 (33.5)		19.7 (8.9)	23.9 (10.8)	19.7 (8.9)	16.5 (7.5)	110 (33.5)		17.8 (8.1)	21.5 (9.8)	21.5 (9.8)	15.4 (7.0)	110 (33.5)		15.2 (6.9)	17.4 (7.9)	18.2 (8.3)	13.6 (6.2)
120 (36.6)		18.1 (8.2)	21.1 (9.6)	17.4 (7.9)	16.1 (7.3)	120 (36.6)		16.6 (7.5)	20.1 (9.1)	20.2 (9.2)	15.0 (6.8)	120 (36.6)		14.4 (6.5)	16.5 (7.5)	18.0 (8.2)	13.2 (6.0)
130 (39.6)		16.7 (7.6)	18.8 (8.5)	15.4 (7.0)	15.6 (7.1)	130 (39.6)		15.5 (7.0)	18.9 (8.6)	17.8 (8.1)	14.6 (6.6)	130 (39.6)			15.7 (7.1)	17.4 (7.9)	12.9 (5.9)
140 (42.7)		15.5 (7.0)	16.9 (7.7)	13.7 (6.2)	14.2 (6.4)	140 (42.7)			17.1 (7.8)	15.8 (7.2)	14.2 (6.4)	140 (42.7)			15.1 (6.8)	16.2 (7.3)	12.6 (5.7)
150 (45.7)			15.2 (6.9)	12.3 (5.6)	12.5 (5.7)	150 (45.7)			15.3 (6.9)	14.0 (6.4)	13.0 (5.9)	150 (45.7)			14.5 (6.6)	14.4 (6.5)	12.4 (5.6)
160 (48.8)			13.8 (6.3)	10.8 (4.9)	10.9 (4.9)	160 (48.8)			13.8 (6.3)	12.5 (5.7)	11.4 (5.2)	160 (48.8)			14.0 (6.4)	12.8 (5.8)	11.8 (5.4)
170 (51.8)			12.5 (5.7)	9.5 (4.3)	9.4 (4.3)	170 (51.8)			12.5 (5.7)	11.1 (5.0)	9.9 (4.5)	170 (51.8)				11.5 (5.2)	10.4 (4.7)
180 (54.9)			11.4 (5.2)	8.4 (3.8)	8.1 (3.7)	180 (54.9)				9.7 (4.4)	8.6 (3.9)	180 (54.9)				10.1 (4.6)	9 (4.1)
190 (57.9)				7.3 (3.3)	7.0 (3.2)	190 (57.9)				8.5 (3.9)	7.4 (3.4)	190 (57.9)				8.8 (4.0)	7.8 (3.5)
200 (61.0)				6.4 (2.9)	6.0 (2.7)	200 (61.0)				7.5 (3.4)	6.3 (2.9)	200 (61.0)					6.7 (3.0)
210 (64.0)				5.5 (2.5)	5.0 (2.3)	210 (64.0)				6.5 (2.9)	5.4 (2.4)	210 (64.0)					5.7 (2.6)
220 (67.1)				4.7 (2.1)	4.2 (1.9)	220 (67.1)					4.5 (2.0)	220 (67.1)					4.7 (2.1)
230 (70.1)					3.4 (1.5)	230 (70.1)						230 (70.1)					
240 (73.2)					2.7 (1.2)	240 (73.2)						240 (73.2)					
250 (76.2)					2.1 (1.0)	250 (76.2)						250 (76.2)					

This material is supplied for reference use only. Operator must refer to in-cab Crane Rating Manual and Operator’s Manual to determine allowable crane lifting capacities and assembly and operating procedures.

**Tubular Main Boom + 80 ft (24.38m) Offset Tube Jib -- 360° Rotation**  
**ABCD = 107,600 lb (48 807kg) Counterweight**  
**[All capacities are listed in kips (mt)]**

Load Radius ft (m)	5° Offset					Load Radius ft (m)	15° Offset					Load Radius ft (m)	25° Offset				
	Boom Length – ft (m)						Boom Length – ft (m)						Boom Length – ft (m)				
	50 (15.2)	90 (27.4)	140 (42.7)	190 (57.9)	230 (70.1)		50 (15.2)	90 (27.4)	140 (42.7)	190 (57.9)	230 (70.1)		50 (15.2)	90 (27.4)	140 (42.7)	190 (57.9)	230 (70.1)
35 (10.7)	22.3 (10.1)					35 (10.7)						35 (10.7)					
40 (12.2)	21.6 (9.8)					40 (12.2)						40 (12.2)					
50 (15.2)	20.5 (9.3)	20.9 (9.5)	20.6 (9.3)			50 (15.2)	19.5 (8.8)					50 (15.2)	23.3 (10.6)				
60 (18.3)	19.5 (8.8)	20.1 (9.1)	20.0 (9.1)	18.6 (8.4)		60 (18.3)	18.6 (8.4)	19.0 (8.6)				60 (18.3)	20.3 (9.2)				
70 (21.3)	18.5 (8.4)	19.4 (8.8)	19.4 (8.8)	18.4 (8.3)	15.0 (6.8)	70 (21.3)	17.8 (8.1)	18.3 (8.3)	18.2 (8.3)			70 (21.3)	18.0 (8.2)	16.4 (7.4)			
80 (24.4)	17.5 (7.9)	18.7 (8.5)	18.9 (8.6)	18.0 (8.2)	14.6 (6.6)	80 (24.4)	15.8 (14.1)	17.7 (8.0)	17.8 (8.1)	16.3 (7.4)	13.2 (6.0)	80 (24.4)	16.3 (7.4)	14.9 (6.8)	15.8 (7.2)		
90 (27.4)	15.4 (7.0)	18.1 (8.2)	18.4 (8.3)	17.7 (8.0)	14.3 (6.5)	90 (27.4)	17.0 (12.8)	16.9 (7.7)	17.3 (7.8)	16.2 (7.3)	12.9 (5.9)	90 (27.4)	14.9 (6.8)	13.8 (6.3)	15.1 (6.8)	13.1 (5.9)	
100 (30.5)	13.7 (6.2)	17.5 (7.9)	18.0 (8.2)	17.3 (7.8)	14.0 (6.4)	100 (30.5)	15.5 (11.7)	15.4 (7.0)	16.9 (7.7)	16.0 (7.3)	12.6 (5.7)	100 (30.5)		12.8 (5.8)	14.2 (6.4)	13.0 (5.9)	10.6 (4.8)
110 (33.5)	12.4 (5.6)	16.0 (7.3)	17.5 (7.9)	17.0 (7.7)	13.6 (6.2)	110 (33.5)	10.9 (11.7)	14.2 (6.4)	16.6 (7.5)	15.8 (7.2)	12.3 (5.6)	110 (33.5)		11.9 (5.4)	13.4 (6.1)	12.9 (5.9)	10.4 (4.7)
120 (36.6)	11.3 (5.1)	14.6 (6.6)	17.1 (7.8)	16.6 (7.5)	13.3 (6.0)	120 (36.6)		13.1 (5.9)	15.6 (7.1)	15.6 (7.1)	12.1 (5.5)	120 (36.6)		11.2 (5.1)	12.6 (5.7)	12.8 (5.8)	10.2 (4.6)
130 (39.6)		13.4 (6.1)	16.7 (7.6)	16.3 (7.4)	13.0 (5.9)	130 (39.6)		12.3 (5.6)	14.6 (6.6)	15.5 (7.0)	11.8 (5.4)	130 (39.6)		10.6 (4.8)	12.0 (5.4)	12.7 (5.8)	10.0 (4.5)
140 (42.7)		12.4 (5.6)	15.8 (7.2)	15.7 (7.1)	12.7 (5.8)	140 (42.7)		11.5 (5.2)	13.7 (6.2)	15.3 (6.9)	11.6 (5.3)	140 (42.7)		10.1 (4.6)	11.4 (5.2)	12.5 (5.7)	9.8 (4.4)
150 (45.7)		11.6 (5.3)	14.7 (6.7)	14.0 (6.4)	12.4 (5.6)	150 (45.7)		10.9 (4.9)	13.0 (5.9)	14.4 (6.5)	11.3 (5.1)	150 (45.7)			11.0 (5.0)	12.0 (5.4)	9.7 (4.4)
160 (48.8)		10.9 (4.9)	13.7 (6.2)	12.5 (5.7)	11.2 (5.1)	160 (48.8)			12.3 (5.6)	12.9 (5.9)	11.1 (5.0)	160 (48.8)			10.5 (4.8)	11.5 (5.2)	9.5 (4.3)
170 (51.8)			12.7 (5.8)	11.2 (5.1)	9.8 (4.4)	170 (51.8)			11.7 (5.3)	11.6 (5.3)	10.5 (4.8)	170 (51.8)			10.2 (4.6)	11.1 (5.0)	9.3 (4.2)
180 (54.9)			11.6 (5.3)	9.9 (4.5)	8.5 (3.9)	180 (54.9)			11.2 (5.1)	10.3 (4.7)	9.1 (4.1)	180 (54.9)			9.8 (4.4)	10.7 (4.9)	9.2 (4.2)
190 (57.9)			10.6 (4.8)	8.7 (3.9)	7.3 (3.3)	190 (57.9)			10.7 (4.9)	9.1 (4.1)	7.9 (3.6)	190 (57.9)				9.5 (4.3)	8.4 (3.8)
200 (61.0)			9.7 (4.4)	7.7 (3.5)	6.3 (2.9)	200 (61.0)				8.0 (3.6)	6.8 (3.1)	200 (61.0)				8.3 (3.8)	7.3 (3.3)
210 (64.0)				6.7 (3.0)	5.3 (2.4)	210 (64.0)				7.0 (3.2)	5.8 (2.6)	210 (64.0)				7.3 (3.3)	6.3 (2.9)
220 (67.1)				5.9 (2.7)	4.5 (2.0)	220 (67.1)				6.1 (2.8)	4.9 (2.2)	220 (67.1)					5.3 (2.4)
230 (70.1)				5.1 (2.3)	3.7 (1.7)	230 (70.1)				5.3 (2.4)	4.1 (1.9)	230 (70.1)					4.5 (2.0)
240 (73.2)				4.4 (2.0)	3.0 (1.4)	240 (73.2)					3.4 (1.5)	240 (73.2)					3.7 (1.7)
250 (76.2)				3.7 (1.7)	2.4 (1.1)	250 (76.2)					2.7 (1.2)	250 (76.2)					

This material is supplied for reference use only. Operator must refer to in-cab Crane Rating Manual and Operator's Manual to determine allowable crane lifting capacities and assembly and operating procedures.

**This Page Intentionally Blank**

**Link-Belt Construction Equipment Company** Lexington, Kentucky [www.linkbelt.com](http://www.linkbelt.com)

®Link-Belt is a registered trademark. Copyright 2014. We are constantly improving our products and therefore reserve the right to change designs and specifications.