

## SELF ERECTING CRANES

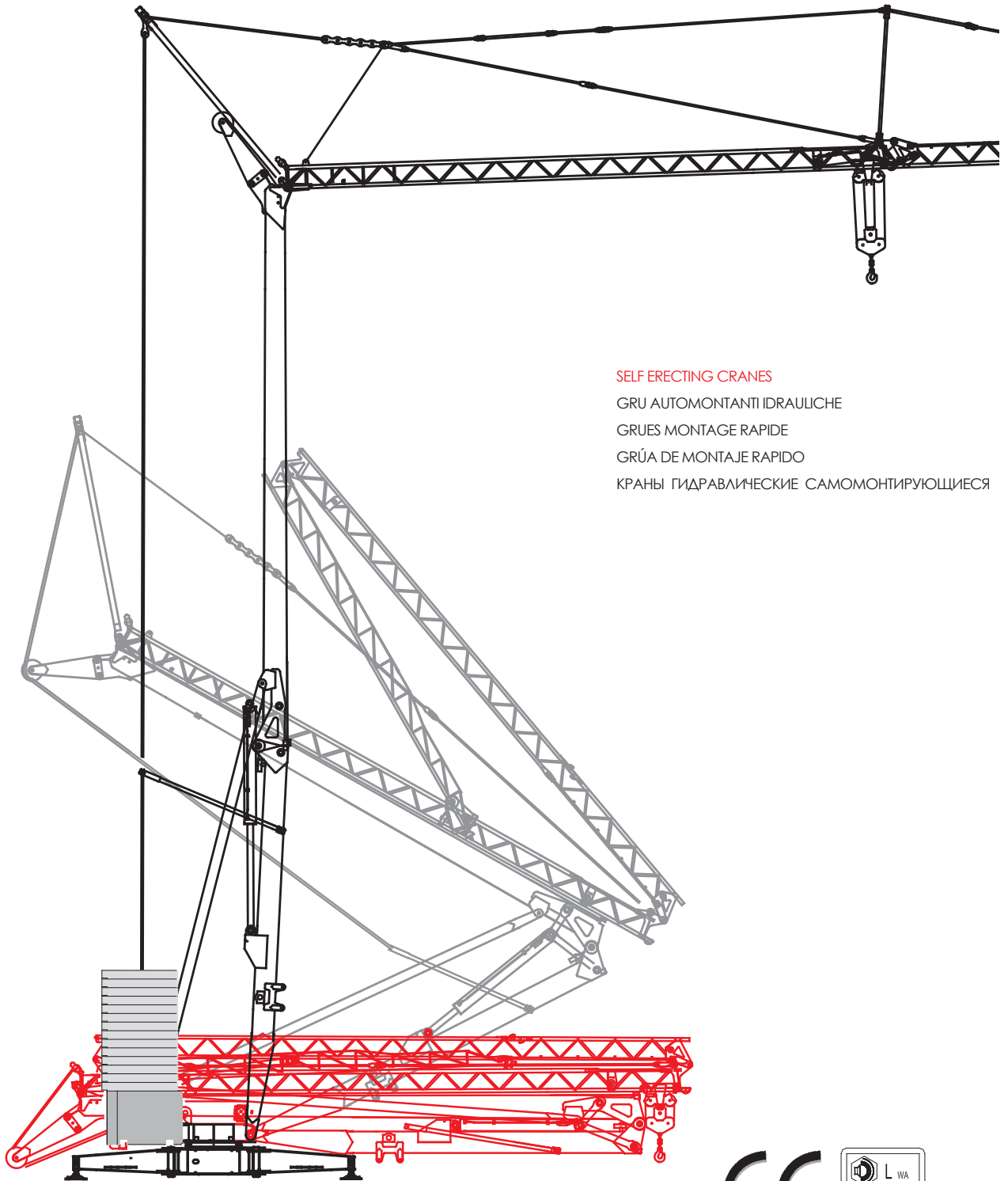

### SELF ERECTING CRANES

GRU AUTOMONTANTI IDRAULICHE

GRUES MONTAGE RAPIDE

GRÚA DE MONTAJE RAPIDO

КРАНЫ ГИДРАВЛИЧЕСКИЕ САМОМОНТИРУЮЩИЕСЯ



H1B3 - DIN 15018

**TOWER CONFIGURATION - REACTIONS**

CONFIGURAZIONE TORRE - REAZIONI / CONFIGURATION TOUR - RÉACTIONS / TORRE DE CONFIGURACIÓN - REACCIONES / КОНФИГУРАЦИЯ БАШНИ — РЕАКЦИИ

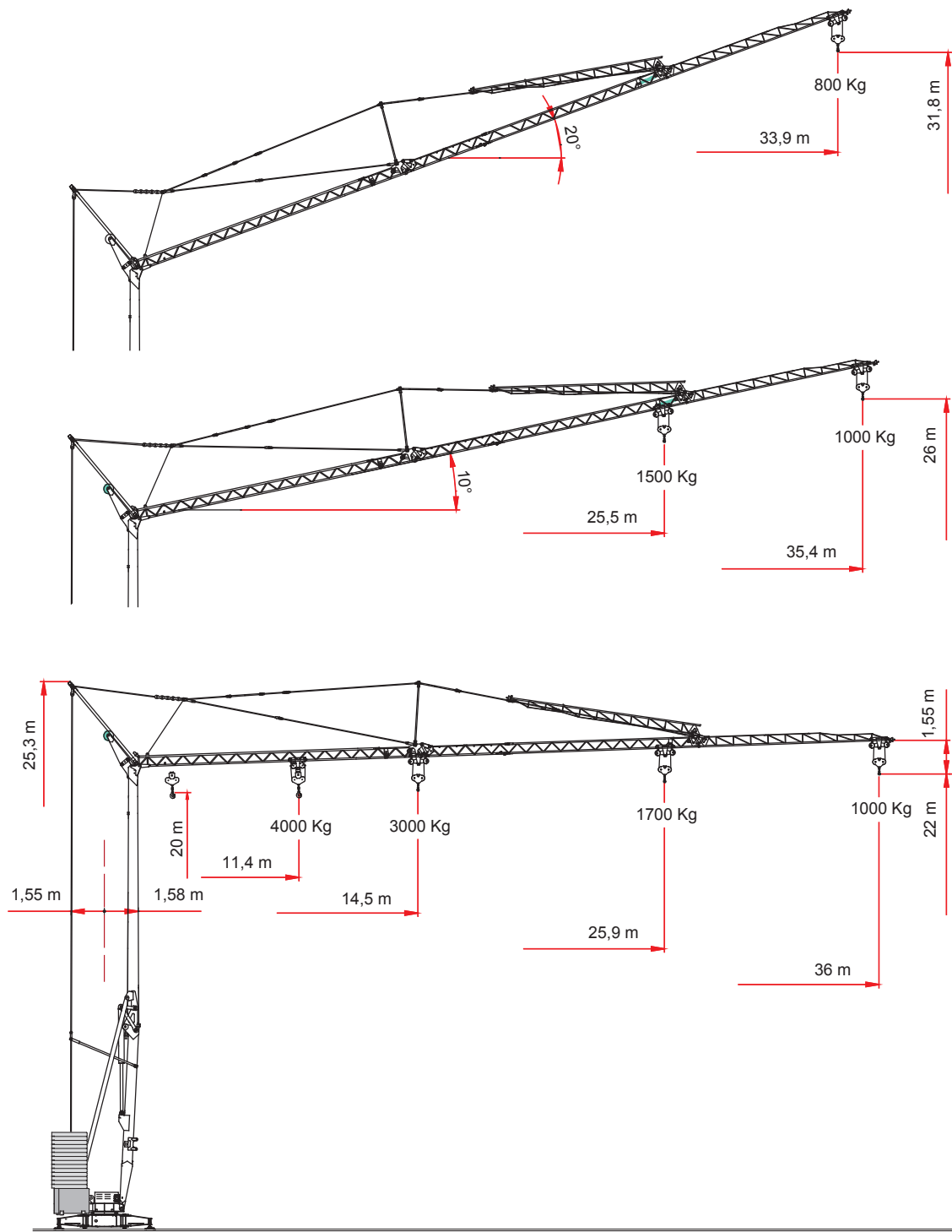

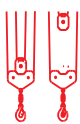
kg.	3000	2670	2320	2046	1825	1644	1493	1364	1254	1158	1074	1000		
m.	14.5	16.0	18.0	20.0	22.0	24.0	26.0	28.0	30.0	32.0	34.0	36.0		
kg.	4000	3792	3092	2601	2236	1956	1733	1552	1402	1275	1167	1073	1000	
m.	10.5	11.0	13.0	15.0	17.0	19.0	21.0	23.0	25.0	27.0	29.0	31.0	33.0	

## MECHANISMS

MECCANISMI / MÉCANISMES / MECANISMOS / МЕХАНИЗМЫ

 400 V (+10% - 10%) 50 Hz 12 kVA



m/l'	8	20	46	56
kg	3000	3000	1200	800
kW	11 (Inverter)			



m/l'	8 - 4	20 - 10	46 - 23	56 - 28
kg	2000 - 4000	2000 - 4000	1200 - 2400	800 - 1600
kW	11 (Inverter)			



g/l'	16	26	48.7 (↗ 35.7)
kW	3 (Inverter)		



m/l'	0.17	0.43	0.85
kW	3 (Inverter)		



15.500 Kg.

8.000 Kg. + 16.900 Kg.

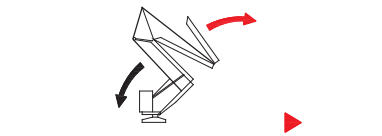
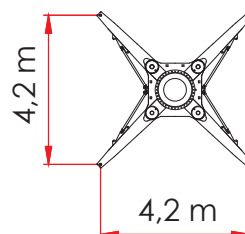

min	18
kW	3

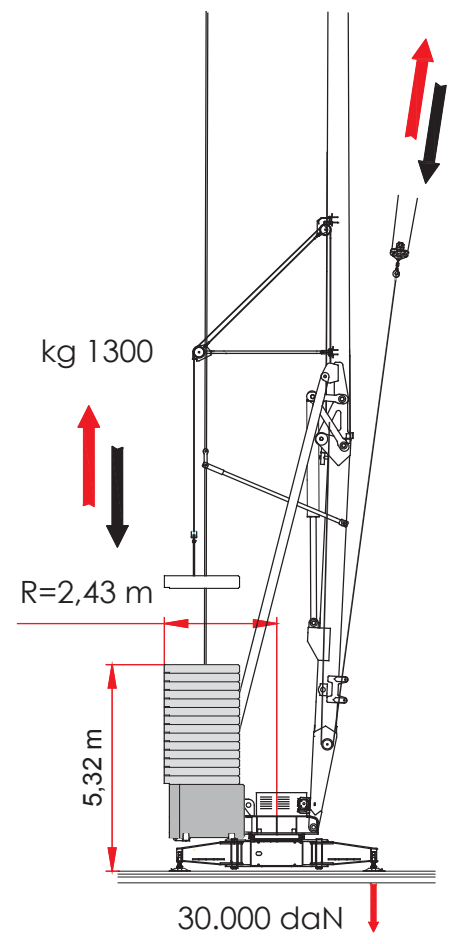

## F [daN]

MAX STRESSES  
AT THE FOOT

SFORZI MASSIMI  
AL PIEDE

EFFORTS MAX.  
AU PIED

MÁXIMO ESFUERZOS  
A LOS PIES

МАКС. УСИЛИЯ НА  
ПОДНОЖИЕ

## ERECTION PROCEDURE ON 360°

SEQUENZA DI MONTAGGIO SU 360° / DÉROULEMENT DE MONTAGE SUR 360° / SECUENCIA DE MONTAJE DE 360° / ХАРАКТЕРИСТИКА ГЛАВНЫХ ПРИВОДОВ 360°

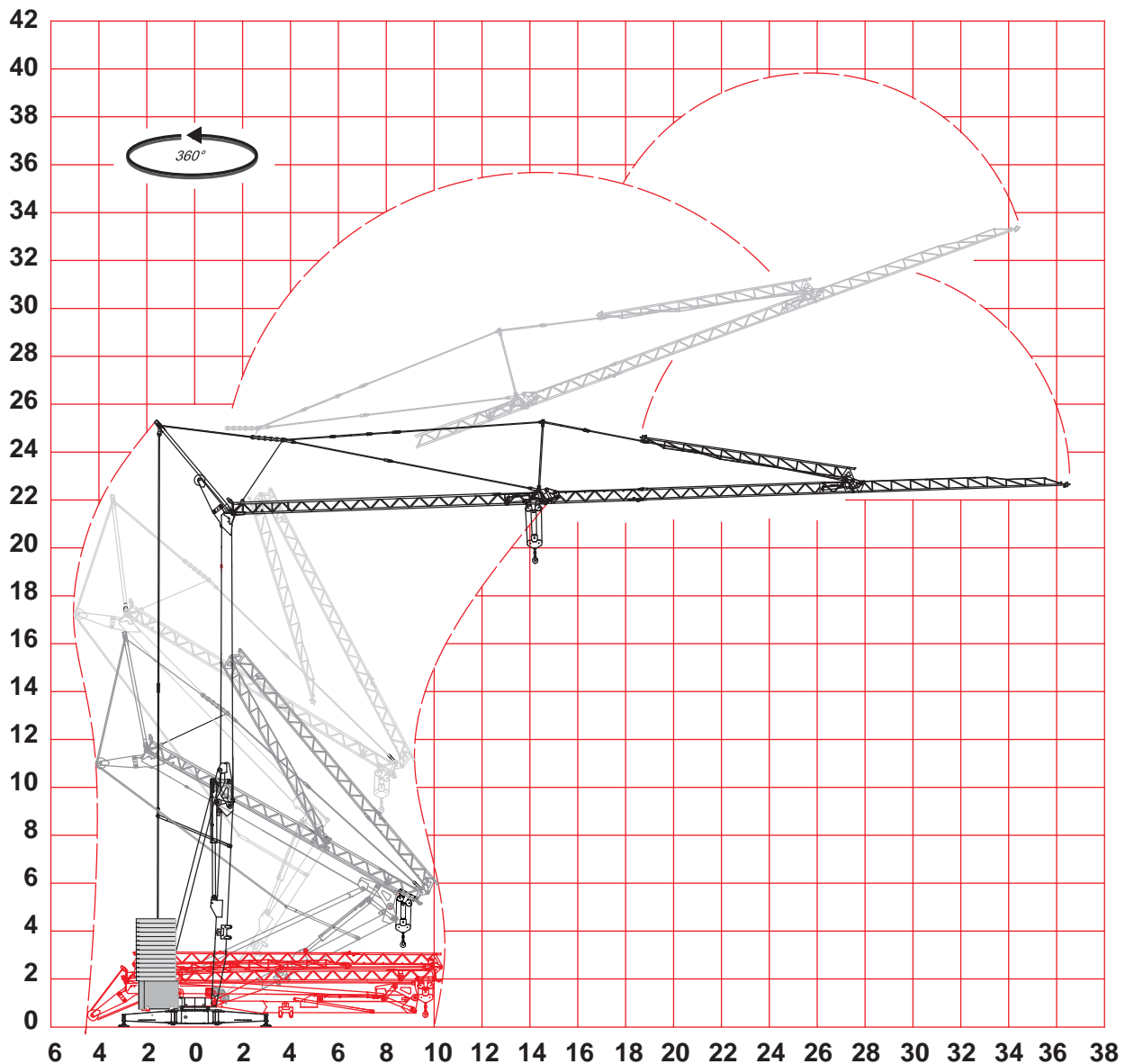

### MONTAGE

MONTAGGIO

MONTAGE

MONTAJE

СОБРАНИА

TRACK LOAD PLAN

SOLUZIONE DI TRAINO / PLAN DE CHARGEMENT / REMOLQUE DE SOLUCIÓN / ВАРИАНТ БУКСИРОВКИ

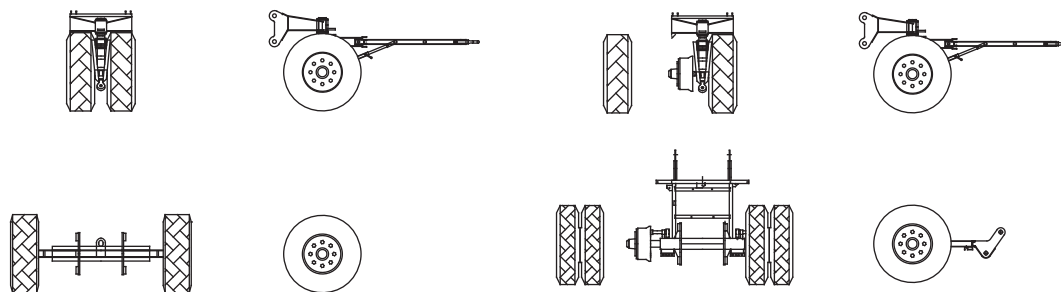
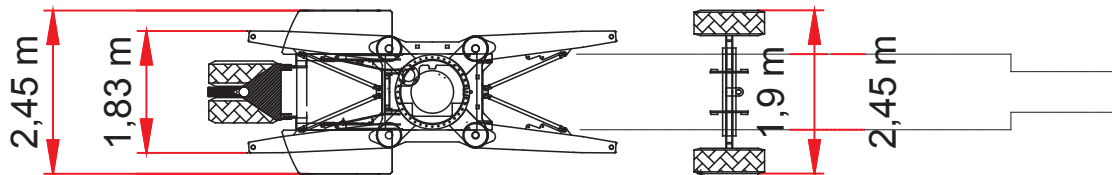
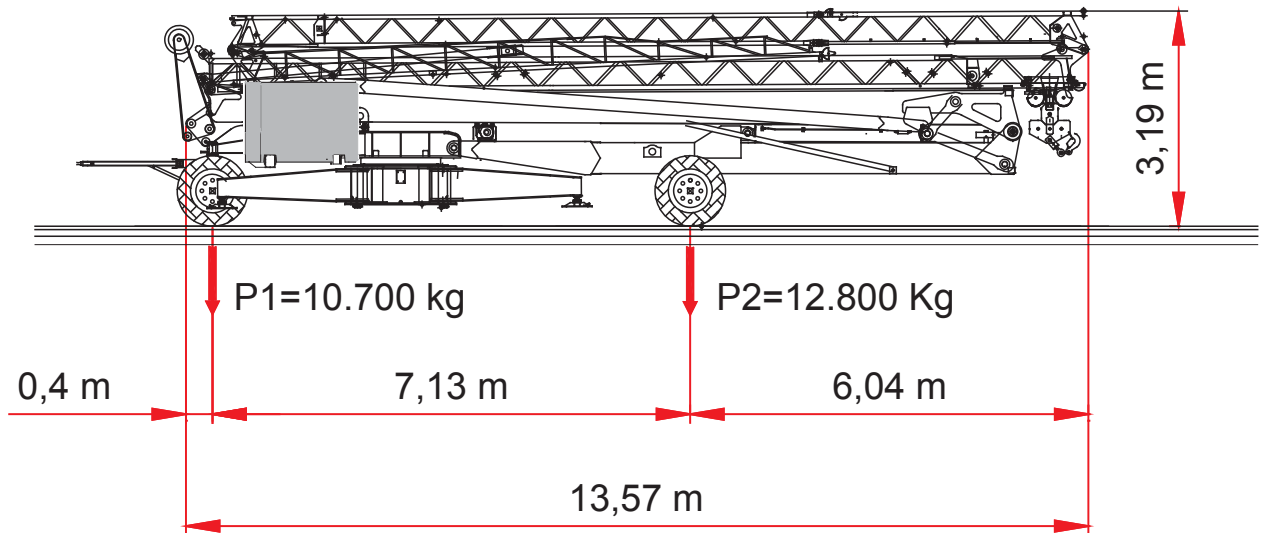

4 x 385-R 22.5

Freni - Brakes - Freins

Bremse - Frenos

[ HR 36 \_REV. \_0312 ] ADL / TECHNICAL DEPARTEMENT

---

THE DATA OBJECT OF THESE SHEETS ARE SUBJECT TO CHANGE WITHOUT PRIOR NOTICE / I DATI OGGETTO DELLE PRESENTI SCHEDE POTREBBERO SUBIRE MODIFICHE SENZA PREAVVISO / LES INFORMATIONS DONNÉES DANS LES PRÉSENTES FICHES POURRAIENT SUBIR DES MODIFICATIONS SANS PRÉAVIS / LOS DATOS CONTENIDOS EN ESTE FORMULARIO ESTÁN SUJETAS A CAMBIOS SIN PREVIO AVISO / ДАННЫЕ, УКАЗАННЫЕ В НАСТОЯЩИХ СПЕЦИФИКАЦИЯХ, МОГУТ ИЗМЕНЯТЬСЯ БЕЗ ПРЕДВАРИТЕЛЬНОГО ПРЕДУПРЕЖДЕНИЯ.