

### 3095F SIDE VIEW DIAGRAM

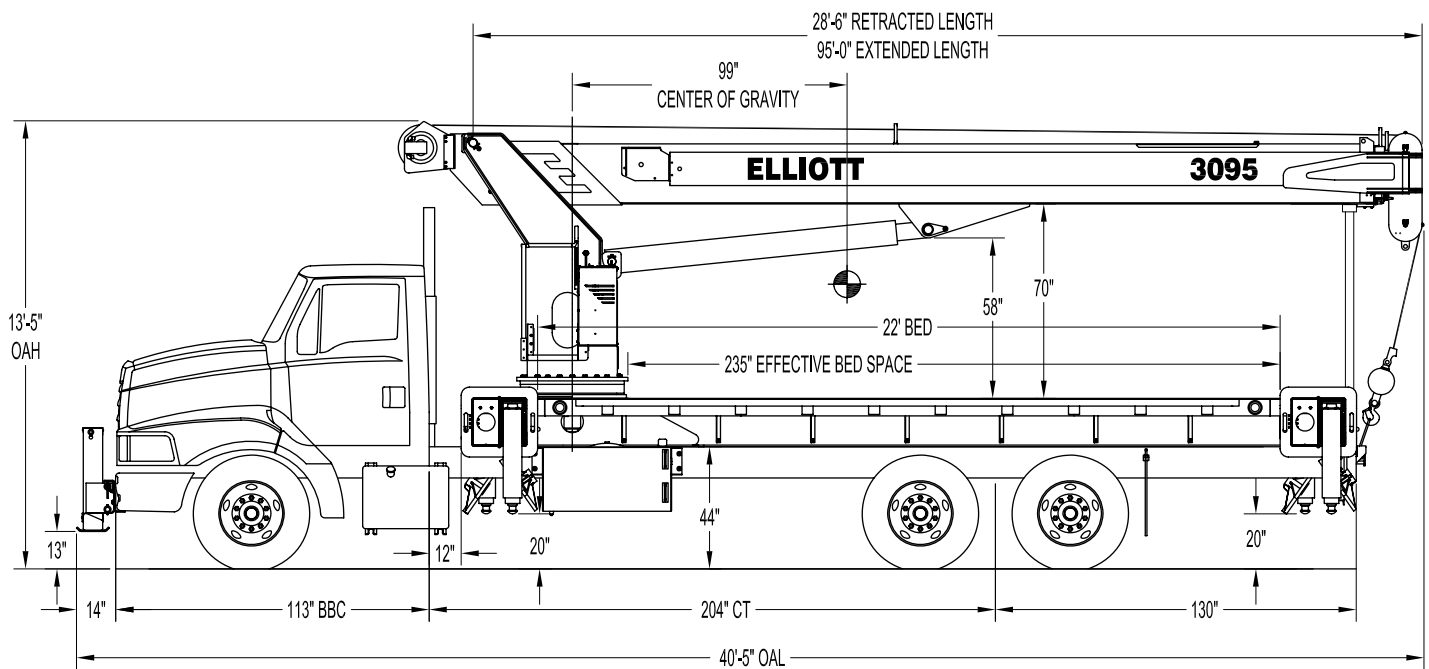

- |                                  |                                     |                                 |                  |
|----------------------------------|-------------------------------------|---------------------------------|------------------|
| • <b>Maximum Vertical Reach</b>  | 148'/45,1 m                         | • <b>Powered Boom Sections</b>  | 4                |
| • <b>Working Area</b>            | 180 Degrees Standard (360 Optional) | • <b>Overall Height</b>         | 13'5"/4,1 m      |
| • <b>Lifting Capacity</b>        | 60,000 lbs/27 216 kg                | • <b>Operator Controls</b>      | Rotating Standup |
| • <b>Boom Length</b>             | 95'/29 m                            | • <b>Outrigger Type Front</b>   | Out-Down         |
| • <b>Crane Weight (Standard)</b> | 27,750 lbs/12 587 kg                | • <b>Outrigger Spread Front</b> | 20'6 m           |
| • <b>Jib Lengths</b>             | 24'-41'/ 7,3-12,5 m                 | • <b>Outrigger Type Rear</b>    | Out-Down         |
| • <b>Winch Bare Drum Pull</b>    | 12,800 lbs/5806 kg                  | • <b>Outrigger Spread Rear</b>  | 20'6 m           |

## TECHNICAL SPECIFICATIONS

**Crane Capacity:** 60,000 lbs at 5' load radius.

**Maximum Tip Height:** 107' height (148' with optional 41' jib)

**Control Console:** Rotating turret single operator standup control station equipped with four single axis control levers for the main crane controls. Operator station includes LMI display, bubble level gauge, engine start/stop switch, signal horn button, variable speed throttle switch, lifting capacity chart, range diagram chart, boom angle indicator, system pressure gauge, 12V DC power source, and cup holder. Independent ground level electric operated outrigger controls.

**Boom:** Four-section fully proportional, high strength steel plated rectangular tube sections. A maximum boom tip height of 107' mounted on a truck. The boom nose contains one floating upper sheave and three lower sheaves. Assembly includes heavy-duty cylinder fittings, pivot pins, and replaceable wear pads.

**Winch:** Mounted at the base of the boom for a long fleet angle and flat level spooling of cable. Winch is driven by a planetary reducer and powered by a hydraulic motor. Burst-of-speed winch provides increased line speed. The winch brake is spring applied, pressure release design. Supplied with 425' of 9/16" diameter rotation resistant wire rope with a single line pull of 9,060 pounds, and a downhaul ball with swivel hook for single part line.

**Load Moment Indicator System:** System senses hoist cylinder pressures, boom length and boom angle with hydraulic function lockout. The display console is equipped with a bar graph showing crane utilization, boom angle or boom length, a mode select controls for main boom and jib operation, and an anti-two block with an audio/visual warning and shut-off functions to limit hook-boom point contact.

Elliott Equipment Company reserves the right to change the specification of any unit at any time without prior notice. This brochure is only a statement of general specifications on the date of this publication. For more detailed info on specific Elliott trucks go to [www.elliottequip.com](http://www.elliottequip.com)

**Outriggers:** Two sets of out and down overframe outriggers with 20' span. Outriggers are configured for full span, mid span, or retracted operation. Outriggers equipped with ball socket aluminum removable pads that stow on vertical outrigger legs.

**Frame:** Full length, all welded rigid 4-plate design sub-frame. Sub-frame allows for bolt-on addition of 22' bed wings, with top plate of subbase serving as a portion of the bed deck, to form a three-piece bed.

**Turret:** Reverse offset turret is one-piece weldment. Turret rotates on large diameter ball bearing.

**Rotation:** Hydraulic motor drives turret through double reduction planetary swing drive for 372-degree non-continuous rotation. The swing drive system has a spring applied, pressure release brake.

**Lift:** One double-acting long stroke cylinder provides smooth and stable boom elevation. Holding valve prevents boom from falling in event of hose failure.

**Boom Extension:** Incorporates a 2-stage hydraulic extension cylinder, attached to the largest boom section, with a proportional cable extension system driving the outermost sections.

**Hoses:** All high pressure hoses are wire braid reinforced with a minimum safety factor of 4 to 1.

**Cylinders:** All cylinders use microhoned cylinder tubing, chrome shafts, top grade packing and protective rod wipers. Cylinder-mounted holding valves provided on all load-holding cylinders.

**Hydraulic System:** Equipped with cable-shift PTO, piston pump, SAE O-ring face seals on pressure lines, and a 10-micron return line filter. The control valve distributes all flow to hoist system, swing circuit, and other crane functions. System is closed center type.

**Oil Tank Capacity:** 120 gallon mounted to truck frame on roadside.

**Cab Equipment:** PTO cable with indicator lights installed in truck cab. U/L approved 5:BC dry chemical fire extinguisher installed in truck cab.

**Operators Manual & Video:** Two CD copies and one hard copy of operation, maintenance, safety and parts manual provided with each unit. Operational and safety video provided at delivery.

**Installation:** Unit installed on chassis, painted, system and tank filled with oil, tested, inspected, and ready to operate.

**Standard Paint:** Paint turret and boom white, outriggers red, and bed and boxes black. Top of bed painted with black nonskid surface.

**Bumper:** Bureau of Motor Carrier Safety rear bumper.

**Weight:** Approximately 27,750 lbs. with 22' steel-floor bed less truck.

**Truck Chassis Required:** Approx. 204" C.T. RBM 3,300,000 in-lb. per rail, 20,000 lb. front axle and 40,000 lb. GVWR required. Trucks must have front frame extension, 12V electrical system with high capacity alternator, cab clearance stop/tail/backup lights, and I.D. lamps. Recommended GVWR is minimum for BoomTruck with flatbed only. Contact factory when additional equipment is to be added.

**Options:**

24' to 41' 2 Piece Telescopic Jib

Radio Remote Controls

Gravity-Leveled Steel Basket

Tool Box Configurations

Front Jack for 360 Degree Crane Operation

Much more...

**LOAD CHART - MAIN BOOM, FULL-SPAN OUTRIGGERS**



**MODEL 3000 95-ft BOOM**

**MAIN BOOM LOAD RATINGS WITH FULLY EXTENDED OUTRIGGERS**

**MAIN BOOM LOAD RATINGS**

LOAD RATINGS IN lbs WITH OUTRIGGERS AND STABILIZERS EXTENDED

LOAD RADIUS IN FEET	LOADED BOOM ANGLE	LOAD RATINGS IN lbs WITH OUTRIGGERS AND STABILIZERS EXTENDED										
		28-ft	43-ft	56-ft	69-ft	82-ft	95-ft	28-ft	43-ft	56-ft	69-ft	
5	79.5	60,000										
8	72.5	44,000	79.5	32,700								
10	68	37,000	76.5	31,500								
12	63	32,000	74	27,400	78.5	26,800						
14	58	28,100	71	25,400	76.5	24,900	79.5	22,200				
16	53	24,200	68	23,500	74	23,200	78	21,400	77.5	15,800		
20	40.5	20,100	62	19,300	70	19,500	74.5	18,200	74	13,700	79	10,700
25	10.5	14,900	53.5	15,600	64	15,000	70	14,600	70.5	11,800	76.5	10,500
30			43.5	12,300	57.5	12,100	65	11,900	66.5	9,700	73.5	9,400
35			32.5	9,200	51	10,000	60	9,900	62.5	8,300	70.5	8,400
40			7	6,200	44	8,350	55.5	8,300	58	5,700	67	7,350
45					35	6,050	49.5	6,000	53.5	4,700	64	6,950
50					22.5	4,900	43.5	4,950	48.5	4,050	59.5	4,650
55							36.5	4,100	42.2	3,400	56	4,050
60							27.5	3,350	37	2,850	52	3,450
65							13	2,650	30.5	2,350	47.5	2,850
70									21	1,950	43	2,350
75											38	1,950
80											32	1,550
85											25	1,250
90											14.5	950
	0	10,000	0	7,600	0	4,350	0	2,600	0	1,550	0	800
DEDUCTIONS FOR STOWED JIB (lb)		900		600		450		350		300		250
		600		400		300		250		200		200

**JIB LOAD RATINGS**

LOAD RATINGS IN lbs WITH OUTRIGGERS AND STABILIZERS EXTENDED

LOAD RADIUS IN FEET	LOADED BOOM ANGLE	LOAD RATINGS IN lbs WITH OUTRIGGERS AND STABILIZERS EXTENDED					
		24-ft FIXED LENGTH JIB			24-ft EXTENDABLE JIB		
		24-ft JIB	LOADED BOOM ANGLE	24-ft JIB RETRACTED	LOADED BOOM ANGLE	41-ft JIB EXTENDED	
30	74.5	5,450	74.5	5,200	76.5	3,200	
35	72	5,050	72	4,800	74.5	3,050	
40	69.5	4,600	69.5	4,350	72	2,850	
45	67	4,150	67	3,900	70	2,650	
50	64.5	3,750	64.5	3,500	67.5	2,450	
55	61.5	3,300	61.5	3,050	65.5	2,300	
60	58.5	2,800	58.5	2,550	63	2,150	
65	56	2,300	56	2,050	60.5	2,000	
70	53	1,850	53	1,600	58	1,850	
75	50	1,450	50	1,200	55.5	1,600	
80	46.5	1,100	46.5	850	53	1,350	
85	43	800	43	550	50.5	1,100	
90					47.5	850	
95					44.5	600	

ELLIOTT EQUIPMENT CO. SUPPLIED  
LOADLINE EQUIPMENT DEDUCTIONS:  
DOWNHAUL WEIGHT .....180 lbs  
ONE SHEAVE BLOCK.....375 lbs  
TWO SHEAVE BLOCK.....640 lbs  
THREE SHEAVE BLOCK.....870 lbs  
AUXILIARY SHEAVE.....100 lbs

DEDUCTIONS FOR STOWED EXTENDABLE JIB (lbs)

DEDUCTIONS FOR STOWED FIXED LENGTH JIB (lbs)

1-PART LINE	2-PART LINE	3-PART LINE	4-PART LINE	5-PART LINE	6-PART LINE	7-PART LINE	NOTICE
							-DO NOT DEADEND LINE BLOCK (SHORT) FROM TOP WHEN EXTENDING BOOM -KEEP AT LEAST 3 FEET OF LEADLINE ON THE WINCH DRAIN AT ALL TIMES -USE ONLY 1/2" DIA. QUARTER WAVE ROPE AS SPECIFIED BELOW WITH THE PROPER BREAKING STRENGTHS LISTED -ANTI-BLOCK SYSTEM MUST BE USED -OPERATING CAPACITY BEFORE OPERATING CRANE. SEE OPERATOR'S SAFETY MANUAL.
MAX PULL: 9,600 lbs	19,200 lbs	28,800 lbs	38,400 lbs	48,000 lbs	56,000 lbs	60,000 lbs	
MAX PULL: 9,060 lbs	18,120 lbs	27,180 lbs	36,240 lbs	45,300 lbs	54,360 lbs	60,000 lbs	

CRANE MEETS ASME B30.5 REQUIREMENTS AT TIME OF MANUFACTURE

DO NOT PRINT OVER ANY LABELS 115162 11/30



Elliott Equipment Company Phone: 402-592-4500  
4427 South 76th Circle Fax: 402-592-4553  
Omaha, NE 68127 Email: sales@elliottequip.com

**Built for You.**  
www.elliottequip.com

**LOAD CHART - MAIN BOOM, MID-SPAN OUTRIGGERS**



**MODEL 3000 95-ft BOOM**

**MAIN BOOM LOAD RATINGS WITH OUTRIGGERS AT MID-SPAN POSITION**

**MAIN BOOM LOAD RATINGS**

LOAD RATINGS IN lbs WITH OUTRIGGERS AND STABILIZERS EXTENDED

LOAD RADIUS IN FEET	LOADED BOOM ANGLE	28-ft	LOADED BOOM ANGLE	A 43-ft	LOADED BOOM ANGLE	B 56-ft	LOADED BOOM ANGLE	C 69-ft	LOADED BOOM ANGLE	D 82-ft	LOADED BOOM ANGLE	E 95-ft
5	79.5	60,000										
8	72.6	44,000	79.5	32,700								
10	68	37,000	76.6	31,500								
12	63.2	32,000	74	27,400	78.4	26,800						
14	58.1	28,100	71	25,400	76.3	24,900	79.6	22,200				
16	52.7	21,400	68	21,400	74	21,400	78	21,400				
20	40.2	13,700	61.5	13,700	69.2	13,700	74	13,700	77.3	13,700	79.1	10,700
25	16.3	9,000	53.5	9,000	63.7	9,000	69.5	8,950	73.5	8,950	76.4	10,000
30			43.9	6,300	57.4	6,300	65	6,300	69.5	6,300	73.1	7,250
35			31.8	4,550	50.7	4,550	60	4,550	65.4	4,550	69.7	5,500
40			7.1	3,000	43.1	3,350	54.5	3,550	61.2	3,350	65.8	3,200
45					34.1	2,500	49	2,500	57	2,500	62.2	2,400
50					22	1,850	43	1,850	52.4	1,800	58.6	2,000
55							35.5	1,300	47.5	1,300	54.9	1,600
60							27	900	42.3	850	50.9	1,250
65							12.3	500	36.5	500	46.7	950
70											42.1	750
DEDUCTIONS FOR STOWED JIB (lb)		900		600		450		350		300		250
		600		400		300		250		200		200

**JIB LOAD RATINGS**

LOAD RATINGS IN lbs WITH OUTRIGGERS AND STABILIZERS EXTENDED

LOAD RADIUS IN FEET	LOADED BOOM ANGLE	24-ft FIXED LENGTH JIB		24-41 ft EXTENDABLE JIB		
		24-ft JIB	LOADED BOOM ANGLE	24-ft JIB RETRACTED	LOADED BOOM ANGLE	41-ft JIB EXTENDED
30	74.5	5,450	74.5	5,200	76.5	3,200
35	72	4,000	72	3,600	74.5	3,050
40	69.5	2,800	69.5	2,400	72	2,850
45	67	1,950	67	1,600	70	2,650
50	64.5	1,300	64.5	900	67.5	2,150
55	61.5	750			65.5	1,300

ELLIOTT EQUIPMENT CO. SUPPLIED  
 LOADLINE EQUIPMENT DEDUCTIONS:  
 DOWNHAUL WEIGHT .....180 lbs  
 ONE SHEAVE BLOCK.....375 lbs  
 TWO SHEAVE BLOCK.....640 lbs  
 THREE SHEAVE BLOCK.....870 lbs  
 AUXILIARY SHEAVE.....100 lbs

DEDUCTIONS FOR STOWED EXTENDABLE JIB (lbs)

DEDUCTIONS FOR STOWED FIXED LENGTH JIB (lbs)

**1-PART LINE**



MAX PULL: 9,600 lbs

MAX PULL: 9,060 lbs

**2-PART LINE**



19,200 lbs

18,120 lbs

**3-PART LINE**



28,800 lbs

27,180 lbs

**4-PART LINE**



38,400 lbs

36,240 lbs

**5-PART LINE**



48,000 lbs

45,300 lbs

**6-PART LINE**



56,000 lbs

54,360 lbs

**7-PART LINE**



60,000 lbs

60,000 lbs

**NOTICE**

- DO NOT DEADHEAD LINE BLOCK AGAINST BOOM TIP WHEN EXTENDING BOOM.
- KEEP AT LEAST 5 WRAPS OF LOADLINE ON THE WINCH DRUM AT ALL TIMES.
- USE ONLY 9/16" DIAMETER WIRE ROPE, AS SPECIFIED BELOW, WITH THE PROPER BREAKING STRENGTHS LISTED.
- ANTI-TWO-BLOCK SYSTEM MUST BE IN GOOD OPERATING CONDITION BEFORE OPERATING CRANE. SEE OPERATION & SAFETY MANUAL.

9/16" - 6 x 37 IWRC (3.5:1 S.F.)  
 33,600-lbs, BREAKING STRENGTH  
 9/16" - SPIN RESISTANT (5:1 S.F.)  
 45,300-lbs, BREAKING STRENGTH

CRANE MEETS ASME B30.5 REQUIREMENTS AT TIME OF MANUFACTURE

DO NOT PAINT OVER ANY LABELS

1113160 111308



Elliott Equipment Company Phone: 402-592-4500  
 4427 South 76th Circle Fax: 402-592-4553  
 Omaha, NE 68127 Email: sales@elliottequip.com

**Built for You.**  
 www.elliottequip.com

**LOAD CHART - MAIN BOOM, RETRACTED OUTRIGGERS**



**MODEL 3000 95-ft BOOM**

**MAIN BOOM LOAD RATINGS WITH OUTRIGGERS AT FULL HORIZONTAL RETRACTED POSITION**

**MAIN BOOM LOAD RATINGS**

LOAD RATINGS IN lbs WITH OUTRIGGERS AND STABILIZERS EXTENDED

LOAD RADUIS IN FEET	LOADED BOOM ANGLE	LOAD RATINGS IN lbs WITH OUTRIGGERS AND STABILIZERS EXTENDED										
		28-ft	LOADED BOOM ANGLE	A 43-ft	LOADED BOOM ANGLE	B 56-ft	LOADED BOOM ANGLE	C 69-ft	LOADED BOOM ANGLE	D 82-ft	LOADED BOOM ANGLE	E 95-ft
5	79.5	60,000										
8	72.5	22,000	78.9	22,000								
10	67.5	14,900	76.1	14,900								
12	62.8	10,800	73.5	10,800	77.5	10,800						
14	58.9	8,200	70.7	8,200	75.6	8,200	78.7	8,200				
16	53.7	6,500	67.7	6,500	73.5	6,500	76.9	6,500	79.5	6,500		
20	41.6	4,400	61.5	4,400	68.9	4,400	73.5	4,400	76.3	4,400	78.3	4,400
25	16.5	2,550	53.1	2,550	63.1	2,550	68.7	2,550	72.5	2,550	74.9	2,550
30			43.6	1,450	56.8	1,450	63.9	1,450	68.5	1,450	71.6	1,450
35			31.6	700	50.1	700	59.1	700	64.6	700	68.5	700
DEDUCTIONS FOR STOWED JIB (lb)		900		600		450		350		300		250
		600		400		300		250		200		200

ELLIOTT EQUIPMENT CO. SUPPLIED  
 LOADLINE EQUIPMENT DEDUCTIONS:  
 DOWNHAUL WEIGHT .....180 lbs  
 ONE SHEAVE BLOCK.....375 lbs  
 TWO SHEAVE BLOCK.....640 lbs  
 THREE SHEAVE BLOCK.....870 lbs  
 AUXILIARY SHEAVE.....100 lbs

DEDUCTIONS FOR STOWED EXTENDABLE JIB (lbs)

DEDUCTIONS FOR STOWED FIXED LENGTH JIB (lbs)

1-PART LINE	2-PART LINE	3-PART LINE	4-PART LINE	5-PART LINE	6-PART LINE	7-PART LINE	NOTICE
							- DO NOT DEADHEAD LINE BLOCK AGAINST BOOM TIP WHEN EXTENDING BOOM. - KEEP AT LEAST 5 WRAPS OF LOADLINE ON THE WINCH DRUM AT ALL TIMES. - USE ONLY 9/16" DIAMETER WIRE ROPE, AS SPECIFIED BELOW, WITH THE PROPER BREAKING STRENGTHS LISTED. - ANTI-TWO-BLOCK SYSTEM MUST BE IN GOOD OPERATING CONDITION BEFORE OPERATING CRANE. SEE OPERATION & SAFETY MANUAL.
MAX PULL: 9,600 lbs	19,200 lbs	28,800 lbs	38,400 lbs	48,000 lbs	56,000 lbs	60,000 lbs	
MAX PULL: 9,060 lbs	18,120 lbs	27,180 lbs	36,240 lbs	45,300 lbs	54,360 lbs	60,000 lbs	9/16" - 6 x 37 IWRC (3.51 S.F.) 33,600-lbs, BREAKING STRENGTH 9/16" - SPIN RESISTANT (5:1 S.F.) 45,300-lbs, BREAKING STRENGTH

CRANE MEETS ASME B30.5 REQUIREMENTS AT TIME OF MANUFACTURE

DO NOT PAINT OVER ANY LABELS

1113160 111308



Elliott Equipment Company  
 4427 South 76th Circle  
 Omaha, NE 68127  
 Phone: 402-592-4500  
 Fax: 402-592-4553  
 Email: sales@elliottequip.com

**Built for You.**  
 www.elliottequip.com



**RANGE CHART - MAIN BOOM + JIB, FULL-SPAN OUTRIGGERS**



**MODEL 3000 95-ft BOOM**

**RANGE DIAGRAM WITH FULL SPAN OUTRIGGERS**

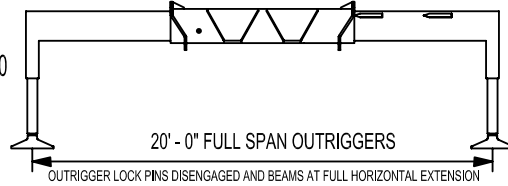
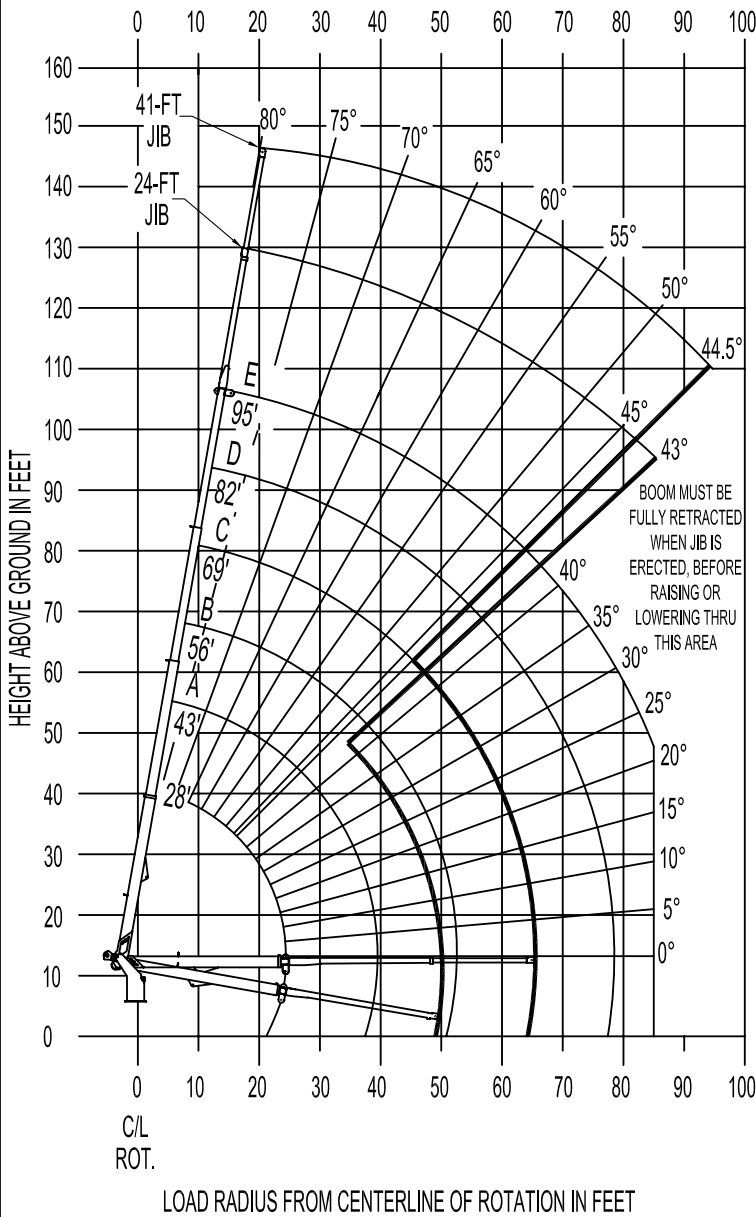

**NOTE:**

1. Operate jib by radius when main boom is full extended. Increase boom angle if necessary to maintain load radius.
2. When boom is retracted, operate jib by boom angles. Do not exceed any rated jib capacities at reduced boom lengths.
3. Capacities do not exceed 85% stability.
4. Load ratings above bold line are structurally limited.
5. Personnel handling is allowed only with full span outriggers.
6. Boom load ratings are based on loaded boom radius. Loaded boom angles are given as reference only.

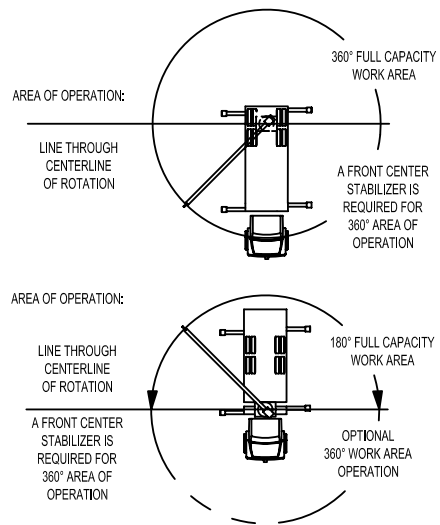

DO NOT PAINT OVER ANY LABELS 1113160 111308



Elliott Equipment Company  
4427 South 76th Circle  
Omaha, NE 68127  
Phone: 402-592-4500  
Fax: 402-592-4553  
Email: sales@elliottequip.com

**Built for You.**  
www.elliottequip.com

**RANGE CHART - MAIN BOOM + JIB, MID-SPAN OUTRIGGERS**



**MODEL 3000 95-ft BOOM**

**RANGE DIAGRAM WITH OUTRIGGERS AT MID-SPAN POSITION**

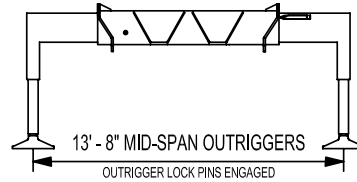
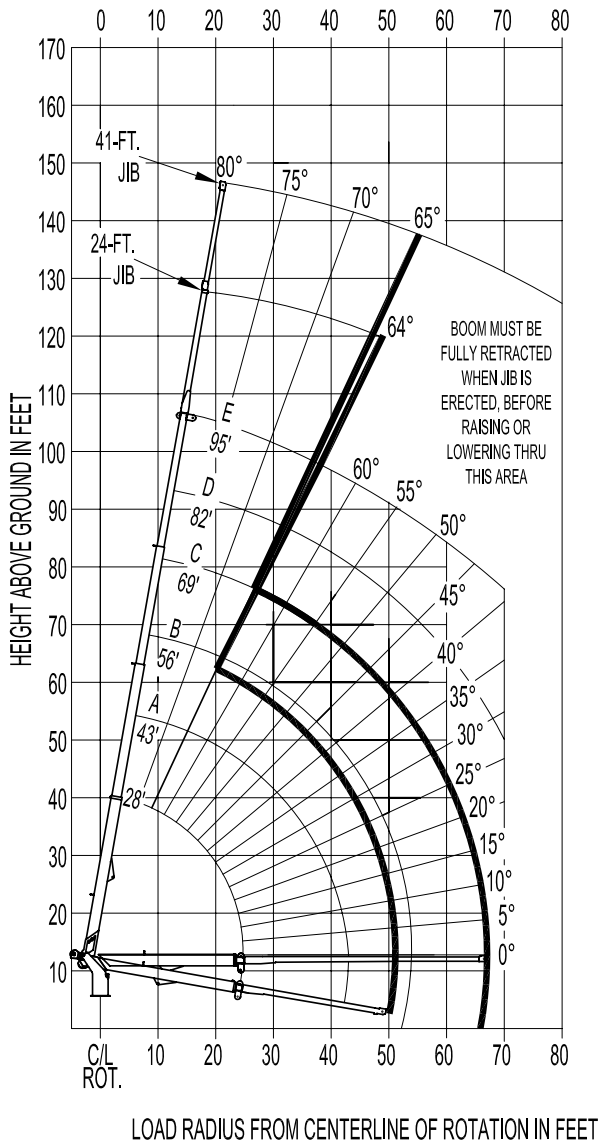

**NOTE:**

1. Operate jib by radius when main boom is full extended. Increase boom angle if necessary to maintain load radius.
2. When boom is retracted, operate jib by boom angles. Do not exceed any rated jib capacities at reduced boom lengths.
3. Capacities do not exceed stability based on ISO 4305-1991.
4. Load ratings above bold line are structurally limited.
5. Personnel handling is allowed only with full span outriggers.
6. Boom load ratings are based on loaded boom radius. Loaded boom angles are given as reference only.

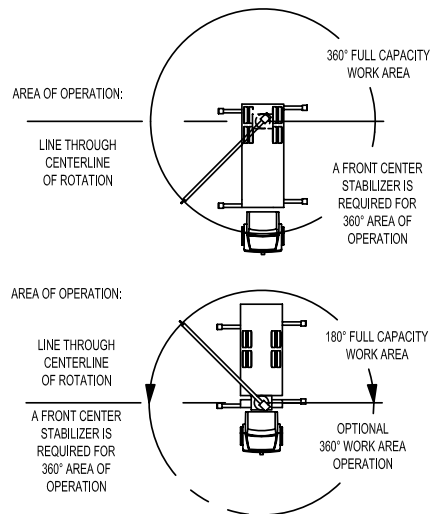

DO NOT PAINT OVER ANY LABELS 1113160 111308

**RANGE CHART - MAIN BOOM, RETRACTED OUTRIGGERS**



**MODEL 3000**

**95-ft BOOM**

**RANGE DIAGRAM WITH OUTRIGGERS  
AT FULL HORIZONTAL RETRACTED POSITION**

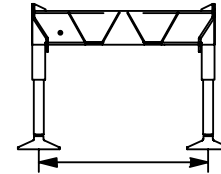
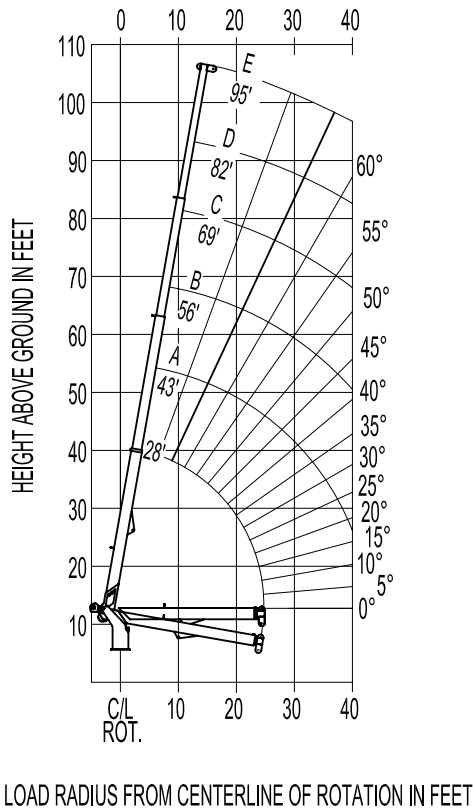

**7' - 5" NO-SPAN OUTRIGGERS**

**NOTE:**

1. Capacities do not exceed stability based on ISO 4305-1991.
2. Load ratings above bold line are structurally limited.
3. Personnel handling is allowed only with full span outriggers.
4. Boom load ratings are based on loaded boom radius.  
Loaded boom angles are given as reference only.

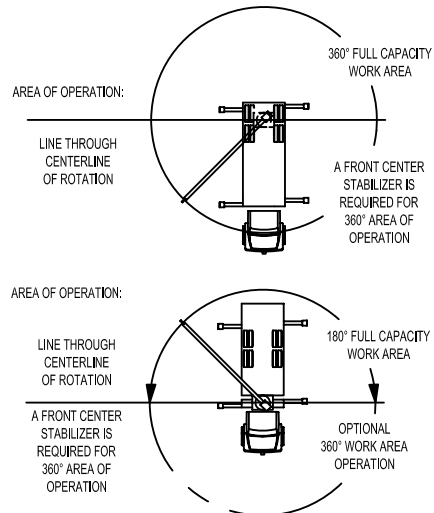

DO NOT PAINT OVER ANY LABELS 1113160 111308



## TRUCK CHASSIS SPECIFICATIONS

	3095F BoomTruck
Wheelbase (WB)	268" / 681 cm
Cab to Tandem (CT)	204" / 518 cm
Cab to End of Frame (EOF)	334" / 848 cm
Frame Section Modulus	30.0 in3-110,000 psi / 492 cm3-758 428 kPa
Front Axle Gross Weight Rating	20,000 lb / 9071 kg
Rear Axle Gross Weight Rating	40,000 lb / 18 143 kg
Integral Front Frame Rails	Required for Front Stabilizer

Chassis data is minimum general requirements-not for engineering.  
 Actual dimensions and truck data will depend on truck selection and axle configuration.  
 \*Minimum chassis weight is required to meet 85% stability requirements.

## OPTIONS



### Radio Remote Control

Interference protected radio remotes let you get closer to your work and have full control over your machine. Includes battery charging feature and optional LMI screen.



### Tool Boxes

Optional tool boxes and bed storage can accommodate any storage need for tools, work materials and more.

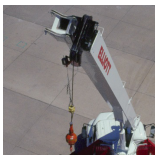

### Pin-On Jib Attachments

One piece & two piece telescoping or fixed jibs that stow on the side of the boom for easy placement while on the worksite.



### Hook Block for Multi-Part Line

Elliott can install a 2-3 part hook block or a 4 part-hook block to improve lifting capabilities. The block can be stored at the rear of the bed.



### Continuous Boom Rotation

Add the convenience of 360 degree continuous rotation by adding a special boom rotation swivel for swinging without stops.

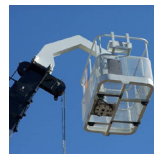

### Gravity Leveled Basket

Elliott's pin-on work platform pins onto the boom for easy installation and removal. Gravity leveling and mechanical rotation makes it a great accessory for any worksite.



### Digger / Auger Attachment

Dig faster and deeper with Elliott's auger attachment, offering 41' of digging range and a hydraulically powered auger that stows on the boom.



### Body Mounted Hose Reels and Circuits

Let us work with you to customize your tool compatibility by adding hose reels or hydraulic circuits to the crane bed.