

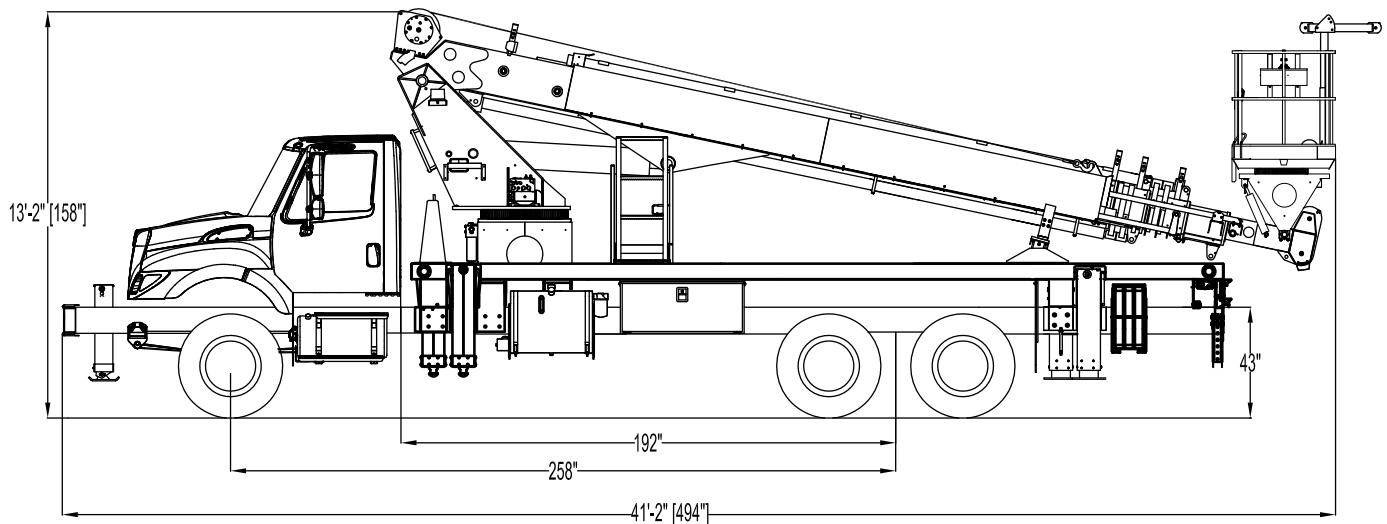

H110F SIDE VIEW DIAGRAM



- | | | | |
|--|-----------------------|---|------------------------|
| • Working Height | 115' / 35 m | • Powered Boom Sections | 5 |
| • Working Side Reach | 84' / 25,6 m | • Overall Height | 13' 2" / 4 m |
| • Platform Capacity | 600 lbs / 272 kg | • Unit Weight (Bare) | 27,500 lbs / 12 474 kg |
| • Platform Size | 40x60 in / 102x152 cm | • Outrigger Spread Main | 22' / 6,7 m |
| • Platform Type | Top Mount | • Outrigger Spread Auxiliary | 18' 2" / 5,5 m |
| • Lifting Capacity (Main Winch) | 14,000 lbs / 6350 kg | • Front Gross Axle Weight Rating | 18,000 lbs / 8165 kg |
| • Jib Winch | 1,000 lbs / 454 kg | • Rear Gross Axle Weight Rating | 40,000 lbs / 18 144 kg |

TECHNICAL SPECIFICATIONS

Maximum Platform Height: 110' ground to platform floor.

Working Range: 115' max. height and 84' max. side reach.

Work Platform: 40x 60" Top-Mount work platform with 40" high rails. Equipped with two safety lanyard attachment loops and two safety harnesses and 72" lanyards. Platform capacity 600 lbs.

Platform Leveling System: Hydraulic "closed" system consisting of twin platform cylinders interacting with a boom-actuated master cylinder mounted in boom support turret. System provided with factory-set relief valves to compensate for oil expansion or overload during platform leveling operation. Remote releveling controls provided in platform and at ground controls to give precise releveling capability.

Platform Controls: Three individual proportional electronic controllers meter pilot-operated, pressure-compensated modulating valves. Remote controls for boom operations from platform operate from a removable remote control box. Hi/Lo range, start/stop and engine speed toggle controls are also located at platform. Electric remote control cable extends through the electrical slip ring to cable carrier on side of boom to extending boom sections.

Lower Controls: Mounted on curbside of turret.

Outrigger Controls: Parallel open-center stack valve for lever-operated control of right and left outriggers. The outrigger valves are mounted at the rear, under each corner of the bed with roadside valve controlling roadside outriggers and curbside valve controlling curbside outriggers.

Outriggers: "H3" type out-and-down main outriggers with 22' spread. "MH" type out-and-down auxiliary outriggers

with 18'2" spread. Single front stabilizer mounted to frame rail extension.

Frame: One piece, all welded, box-type fabrication.

Turret: Reverse offset turret is one-piece weldment mounted on turret box. Turret rotates on large diameter ball bearing.

Rotation: Continuous turret rotation with no stops. Hydraulic motor drives turret through self-locking gear box.

Boom: Steel rectangular tube sections. Assembly includes heavy-duty cylinder fittings, pivot pins, and replaceable wear pads.

Boom Extension: One "piggyback" internal cylinder and two extension cylinders extend the outer boom sections.

Lift: One single-acting full displacement, long stroke cylinder, provides smooth and stable boom elevation. Holding valve prevents boom from falling in event of hose failure.

Cylinders: All cylinders use microhoned cylinder tubing, chrome shafts, top grade packing and protective rod wipers. Cylinder-mounted holding valves provided on all load-holding cylinders.

Hoses: All high pressure hoses are wire braid reinforced with a minimum safety factor of 4 to 1.

Oil Tank Capacity: 70 gallon mounted to truck frame on roadside.

Hydraulic System: Operating pressure is 3,000 PSI. System is parallel open center type and is equipped with liquid-filled pressure gauge. Oil is supplied to upper cylinders through hydraulic union in center of turret to cable carrier along side of the boom.

Pump: Gear type, direct mount to truck PTO.

PTO: Heavy-duty, high-speed.

Cab Equipment: PTO engaged indicator lights installed in truck cab. Engine speed control and start/stop installed with control switches in platform remote control box and also located at lower controls. U/L approved 5:BC dry chemical fire extinguisher installed in truck cab.

Operators Manual & Video: Two CDs and one printed copy of operation, maintenance, safety and parts manual provided with each unit. Operational and safety video provided at delivery.

Installation: Unit installed on truck, painted, system and tank filled with oil, tested, inspected, and ready to operate.

Standard Paint: Paint boom and turret red, outriggers red, and bed and boxes black. Top of bed painted with black nonskid surface.

Bumper: Bureau of Motor Carrier Safety rear bumper.

Weight: Approximately 27,500 lbs. with 26' steel-floor bed less truck.

Truck Chassis Required: Approx. 192" C.T. RBM 2,000,000 in-lb. per rail, 16,000 lb. front axle and 56,000 lb. GVWR required. Trucks must have increased cooling, heavy-duty front and rear springs, 12V electrical system with high capacity alternator, cab clearance stop/tail/backup lights, and I.D. lamps. Extended front frame rails. Recommended GVWR is minimum for HiReach with flatbed only. Contact factory when additional equipment is to be added.

Options:

14,000 lb Capacity Boom Winch.

1,000 lb Capacity Platform Material Handling Jib.

Welder and 110V Lines to Platform.

Custom Toolboxes Configurations.

Much More...

Elliott Equipment Company reserves the right to change the specification of any unit at any time without prior notice. This brochure is only a statement of general specifications on the date of this publication. For more detailed info on specific Elliott trucks go to www.elliottequip.com

MAXIMUM RANGE CAPABILITIES

PLATFORM WORKING RANGE
MODEL H110F

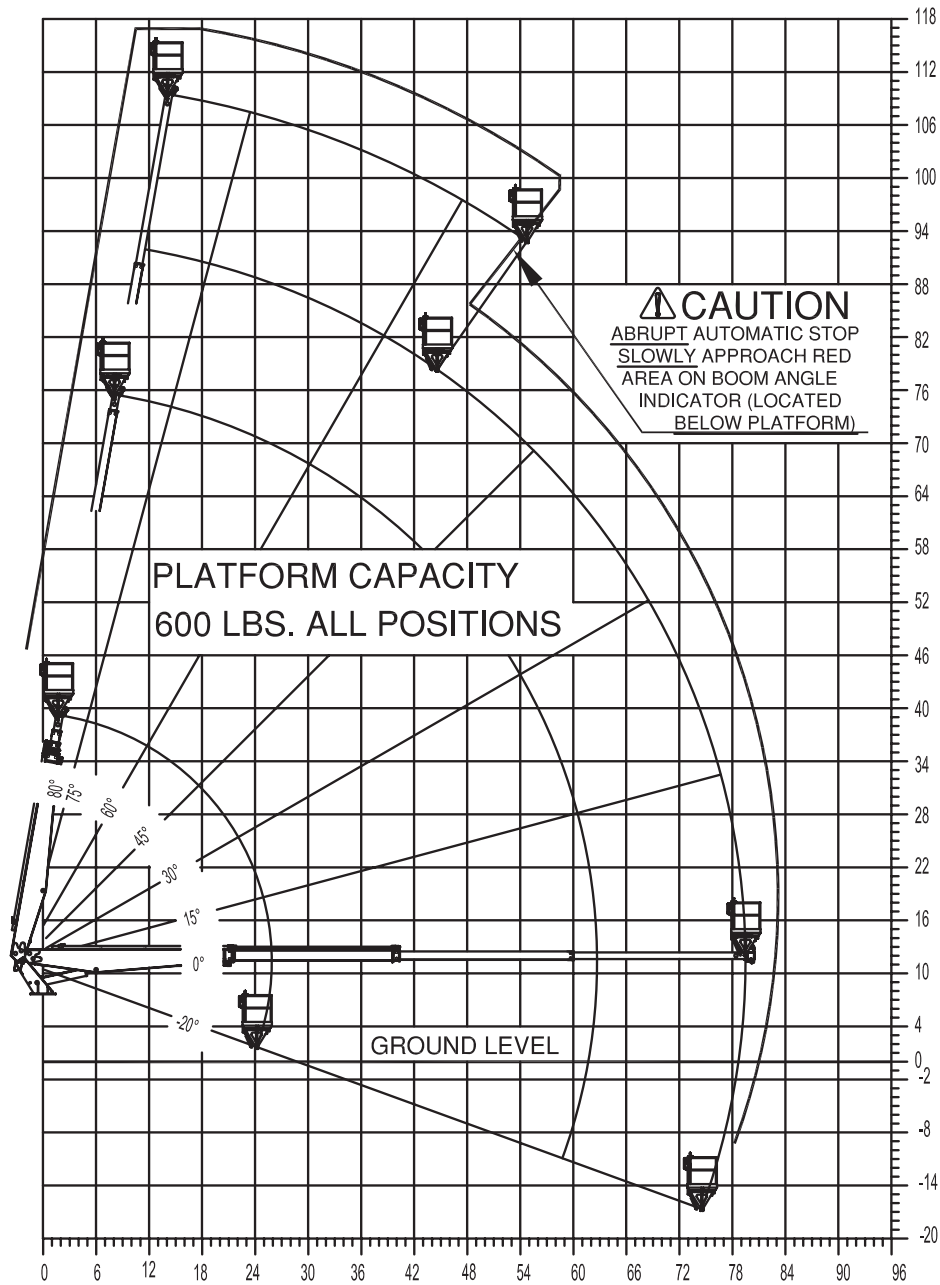

MAXIMUM LIFTING CAPABILITIES

**MAXIMUM WORKING LOADS
CRANE OPERATION**

MODEL H110F

USE OUTRIGGERS AT ALL TIMES • AVOID JERKING LOAD
WINCH LINE LOAD WITH BUCKETS OR PLATFORM REMOVED
360° RADIUS • USE 2 PART LINE FOR LOADS OVER 6000 lbs.
DEDUCT 500 POUNDS IF THE PLATFORM IS NOT REMOVED

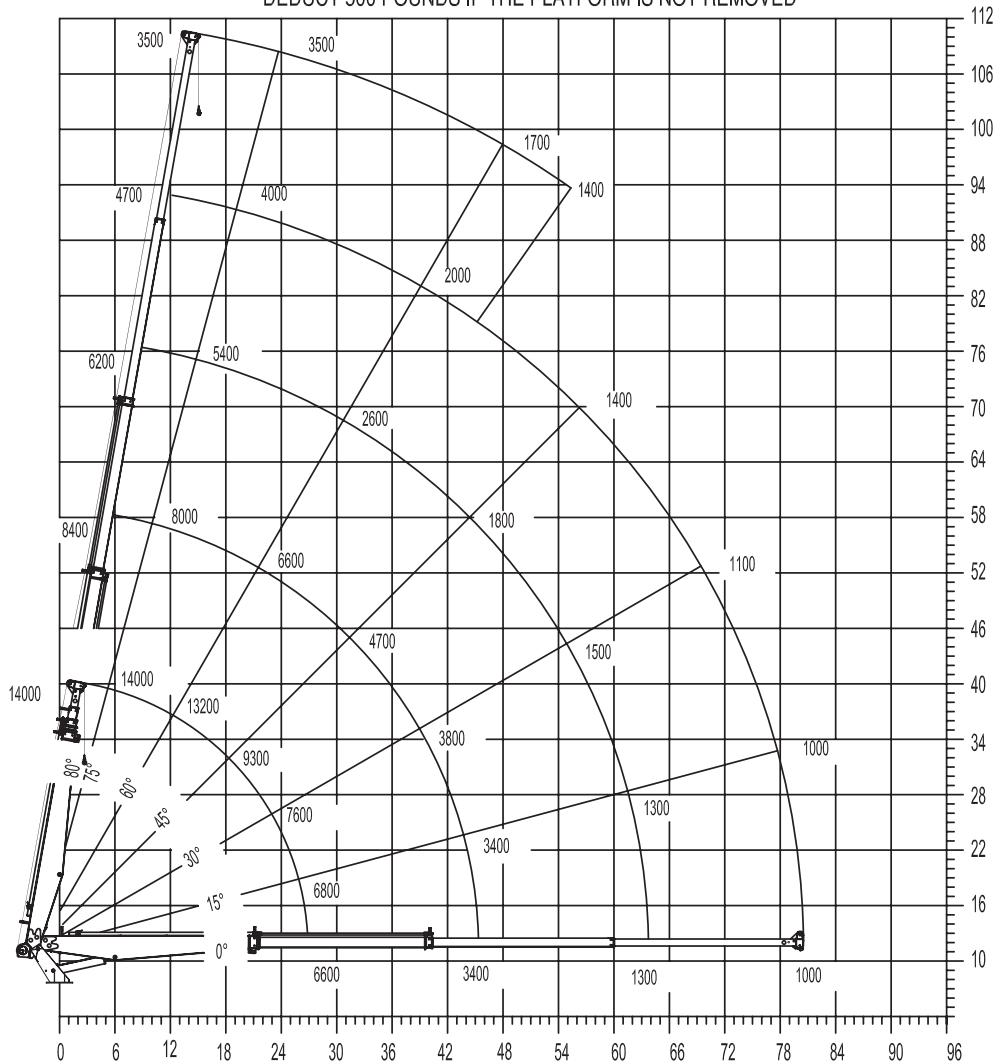

ELLIOTT
EQUIPMENT COMPANY

MAXIMUM JIB LIFTING CAPABILITIES

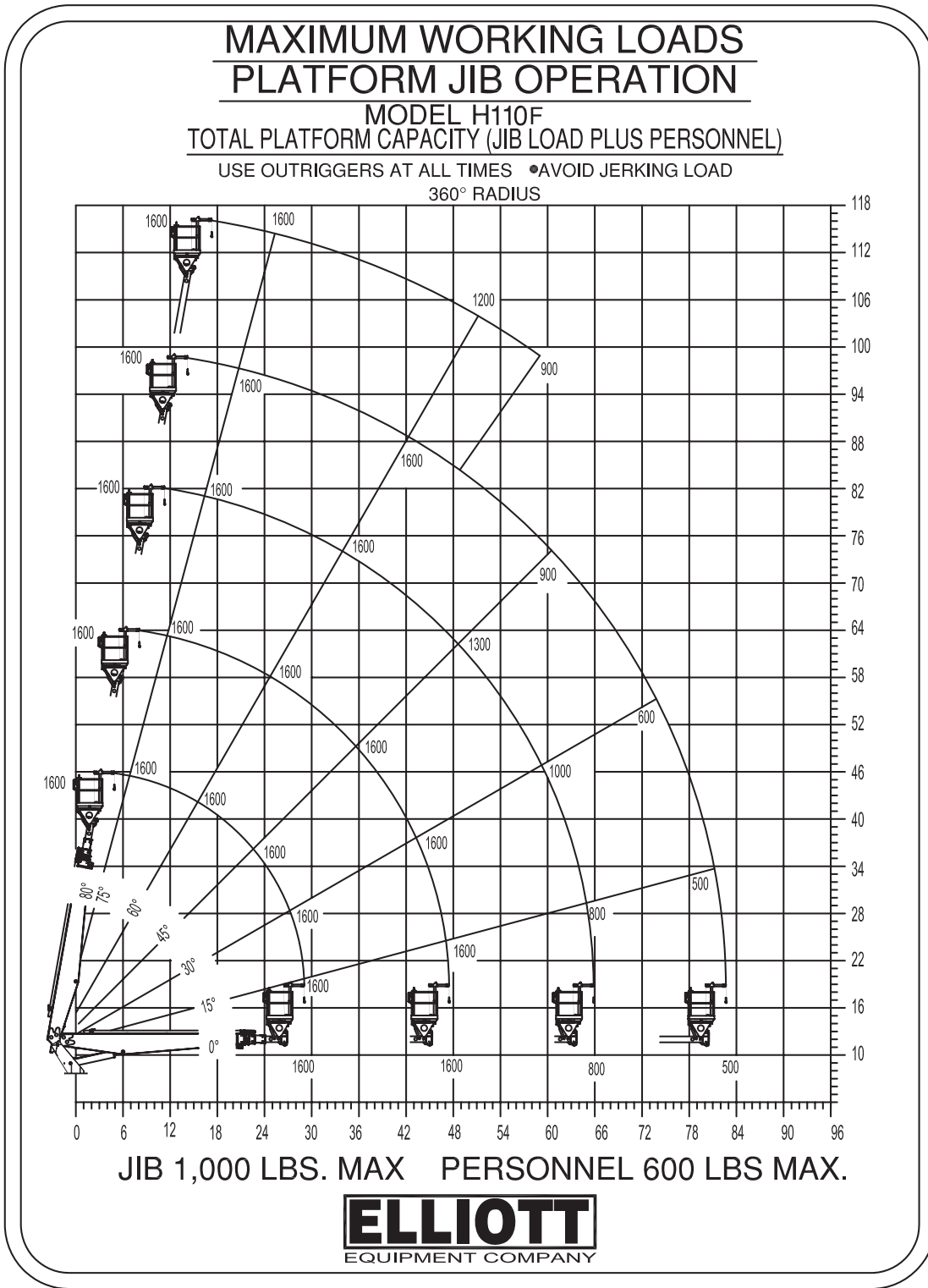

TRUCK CHASSIS SPECIFICATIONS

	H110F
Wheelbase (WB)	258" / 655 cm
Cab to Tandem (CT)	192" / 488 cm
Cab to End of Frame (EOF)	323" / 820 cm
Frame Section Modulus	16.6 in3 / 120,000 psi
Front Axle Gross Weight Rating	18,000 lb / 8165 kg
Rear Axle Gross Weight Rating	40,000 lb / 18 144 kg
Extended Front Frame	Required for Front Stabilizer

OPTIONS



Radio Remote Control

Interference protected radio remotes let you get closer to your work and have full control over your machine.



Material Handling Jib

Equip your HiReach platform with a material handling jib crane to handle up to 1,000 pounds.



Boom-Mounted Winch

Take advantage of the 14,000 lb capacity 2 speed hydraulic winch with 1/2" cable and a load indication system.



Outrigger Pad Holders

Outrigger pad holders safely store your pads for travel and leave plenty of room for tool boxes.



Bed Accessories

Mount a wide variety of accessories including welders, power washers, and generators on the bed.



Platform Accessories

Choose from a list of platform accessories including 110V outlets, welding leads, hydraulic tools, and much more.



Outrigger Extensions

Our pin-on outrigger extensions give you extra clearance for work on hills and around guardrails.



Line Body

Let us work with you to customize a line body to secure your tools and supplies the best way for your application.