

### 36127R SIDE VIEW DIAGRAM

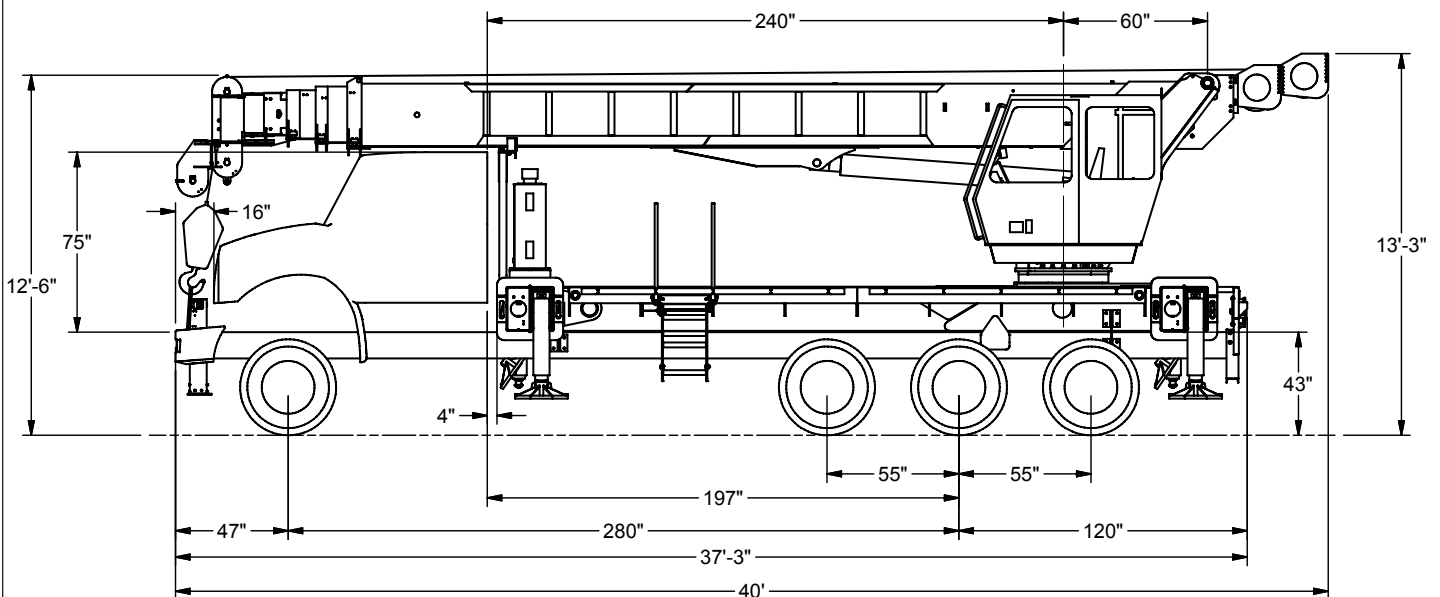

\*Drawing Shows Optional Crane Cab

- |                                  |                                     |                                 |                  |
|----------------------------------|-------------------------------------|---------------------------------|------------------|
| • <b>Maximum Vertical Reach</b>  | 186'/56,7 m                         | • <b>Powered Boom Sections</b>  | 5                |
| • <b>Working Area</b>            | 180 Degrees Standard (360 Optional) | • <b>Overall Height</b>         | 12'11"/3,9 m     |
| • <b>Lifting Capacity</b>        | 72,000 lbs/32 659 kg                | • <b>Operator Controls</b>      | Rotating Standup |
| • <b>Boom Length</b>             | 127'/39m                            | • <b>Outrigger Type Front</b>   | Out-Down         |
| • <b>Crane Weight (Standard)</b> | 33,585 lbs/15 234 kg                | • <b>Outrigger Spread Front</b> | 21'2"/6,4 m      |
| • <b>Jib Lengths</b>             | 32-49'/ 10-15 m                     | • <b>Outrigger Type Rear</b>    | Out-Down         |
| • <b>Winch Bare Drum Pull</b>    | 12,800 lbs/5806 kg                  | • <b>Outrigger Spread Rear</b>  | 21'2"/6,4 m      |

## TECHNICAL SPECIFICATIONS

**Crane Capacity:** 72,000 lbs at 5' load radius.

**Maximum Tip Height:** 137' height (186' with optional 49' jib)

**Control Console:** Rotating turret single operator seated control cab with optional air conditioning, equipped with four single axis control levers for the main crane controls. Operator cab includes LMI display, bubble level gauge, engine start/stop switch, signal horn button, variable speed throttle switch, lifting capacity chart, range diagram chart, boom angle indicator, system pressure gauge, 12V DC power source, and cup holder. Independent ground level electric operated outrigger controls.

**Boom:** Five-section fully proportional, high strength steel plated rectangular tube sections. A maximum boom tip height of 137' mounted on a truck. The boom nose contains one floating upper sheave and three lower sheaves. Assembly includes heavy-duty cylinder fittings, pivot pins, and replaceable wear pads.

**Winch:** Mounted at the base of the boom for a long fleet angle and flat level spooling of cable. Winch is driven by a planetary reducer and powered by a hydraulic motor. Burst-of-speed winch provides increased line speed. The winch brake is spring applied, pressure release design. Supplied with 425' of 9/16" diameter rotation resistant wire rope with a single line pull of 9,060 pounds, and a downhaul ball with swivel hook for single part line.

**Load Moment Indicator System:** System senses hoist cylinder pressures, boom length and boom angle with hydraulic function lockout. The display console is equipped with a bar graph showing crane utilization, boom angle or boom length, a mode select controls for main boom and jib operation, and an anti-two block with an audio/visual warning and shut-off functions to limit

hook-boom point contact.

**Outriggers:** Two sets of out and down overframe outriggers with 21'2" span. Outriggers are configured for full span or mid span operation. Outriggers equipped with ball socket aluminum removable pads that stow on vertical outrigger legs.

**Frame:** Full length, all welded rigid 4-plate design sub-frame. Sub-frame allows for bolt-on addition of 21'5" aluminum bed wings, with top plate of subbase serving as a portion of the bed deck, to form a three-piece bed.

**Turret:** Reverse offset turret is one-piece weldment. Turret rotates on large diameter ball bearing.

**Rotation:** Hydraulic motor drives turret through double reduction planetary swing drive for continuous rotation. The swing drive system has a spring applied, pressure release brake.

**Lift:** One double-acting long stroke cylinder provides smooth and stable boom elevation. Holding valve prevents boom from falling in event of hose failure.

**Boom Extension:** Incorporates a 2-stage hydraulic extension cylinder, attached to the largest boom section, with a proportional cable extension system driving the outermost sections.

**Hoses:** All high pressure hoses are wire braid reinforced with a minimum safety factor of 4 to 1.

**Cylinders:** All cylinders use microhoned cylinder tubing, chrome shafts, top grade packing and protective rod wipers. Cylinder-mounted holding valves provided on all load-holding cylinders.

**Hydraulic System:** Equipped with air-shift PTO, piston pump, SAE O-ring face seals on pressure lines, and a 10-micron return line filter. The control valve distributes all flow to hoist system, swing circuit, and other crane functions.

System is closed center type.

**Oil Tank Capacity:** 120 gallon mounted to truck frame on roadside.

**Cab Equipment:** PTO with indicator lights installed in truck cab. U/L approved 5:BC dry chemical fire extinguisher installed in truck cab.

**Operators Manual & Video:** Two CD copies and one hard copy of operation, maintenance, safety and parts manual provided with each unit. Operational and safety video provided at delivery.

**Installation:** Unit installed on chassis, painted, system and tank filled with oil, tested, inspected, and ready to operate.

**Standard Paint:** Paint turret and boom white, outriggers red, and boxes black.

**Bumper:** Bureau of Motor Carrier Safety rear bumper.

**Weight:** Approximately 33,585 lbs. with 21'5" bed wings less truck.

**Truck Chassis Required:** Approx. 224" C.T. RBM 3,300,000 in-lb. per rail, 20,000 lb. front axle and 73,200 lb. GVWR required. Trucks must have 12V electrical system with high capacity alternator, cab clearance stop/tail/backup lights, and I.D. lamps. Recommended GVWR is minimum for BoomTruck with flatbed only. Contact factory when additional equipment is to be added.

**Options:**

32' to 49' Two-Piece Telescopic Jib

Radio Remote Controls

Gravity-Leveled Steel Basket

Tool Box Configurations

Front Jack for 360 Degree Crane Operation

Line Blocks for Multi-Part Line

Hydraulic Oil Cooler

Much more....

Elliott Equipment Company reserves the right to change the specification of any unit at any time without prior notice. This brochure is only a statement of general specifications on the date of this publication. For more detailed info on specific Elliott trucks go to [www.elliottequip.com](http://www.elliottequip.com)





**RANGE CHART - MAIN BOOM + JIB, FULL-SPAN OUTRIGGERS**



**MODEL 3600**

**127-ft BOOM**

**RANGE DIAGRAM WITH FULL SPAN OUTRIGGERS**

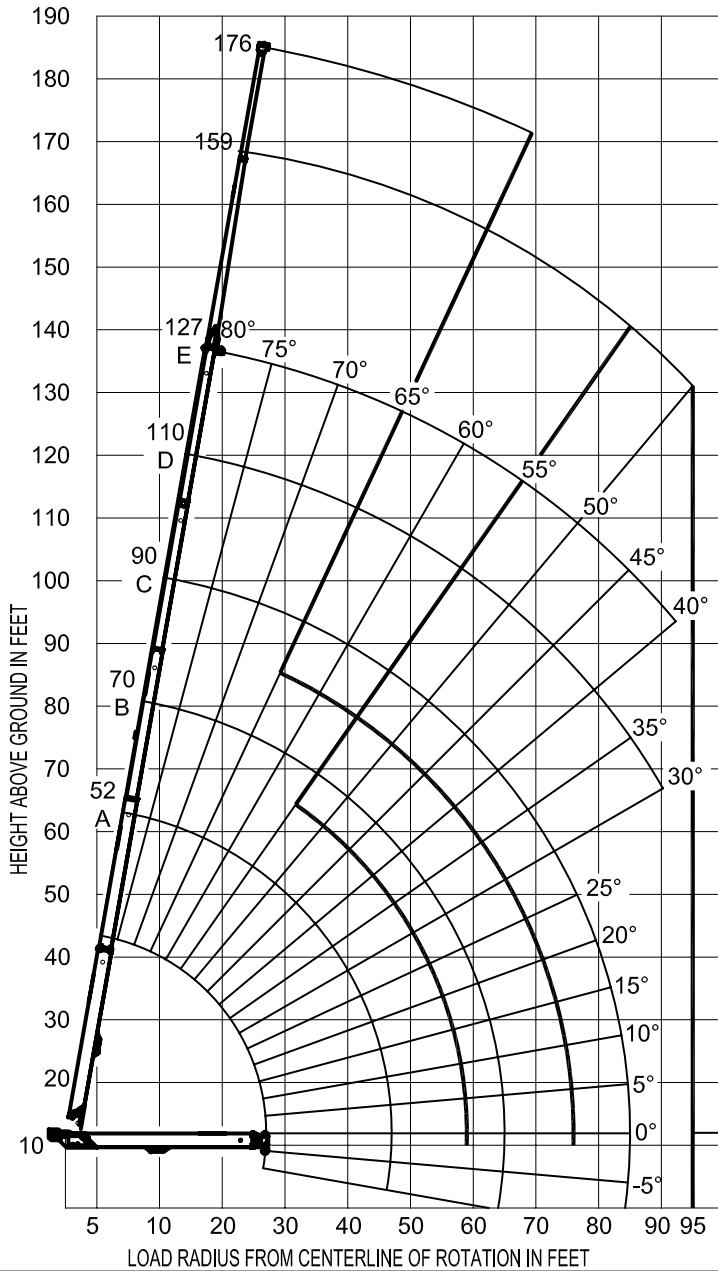

**BOOM DEFLECTION NOT SHOWN**

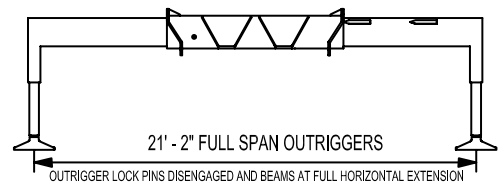

**NOTE:**

1. Operate jib by radius when main boom is fully extended. Increase boom angle if necessary to maintain load radius.
2. When boom is retracted, operate jib by boom angles. Do not exceed any rated jib capacities at reduced boom lengths.
3. Capacities do not exceed 85% stability.
4. Load ratings above bold line are structurally limited.
5. Personnel handling is allowed only with full span outriggers.
6. Boom load ratings are based on loaded boom radius. Loaded boom angles are given as reference only.

**AREA OF OPERATION:**

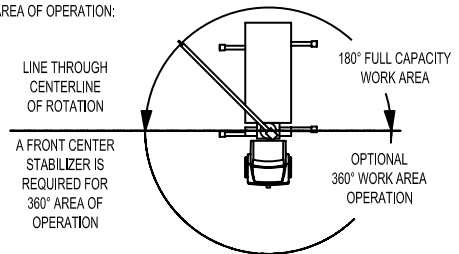

**STABILITY LIMIT LINE (NO LOAD)**

CRANE MEETS ASME B30.5 REQUIREMENTS AT TIME OF MANUFACTURE

DO NOT PAINT OVER ANY LABELS

1172320 022311



Elliott Equipment Company  
4427 South 76th Circle  
Omaha, NE 68127  
Phone: 402-592-4500  
Fax: 402-592-4553  
Email: sales@elliottequip.com

**Built for You.**  
www.elliottequip.com



**RANGE CHART - MAIN BOOM + JIB, MID-SPAN OUTRIGGERS**



**MODEL 3600 127-ft BOOM**

**RANGE DIAGRAM WITH OUTRIGGERS IN MID-SPAN POSITION**

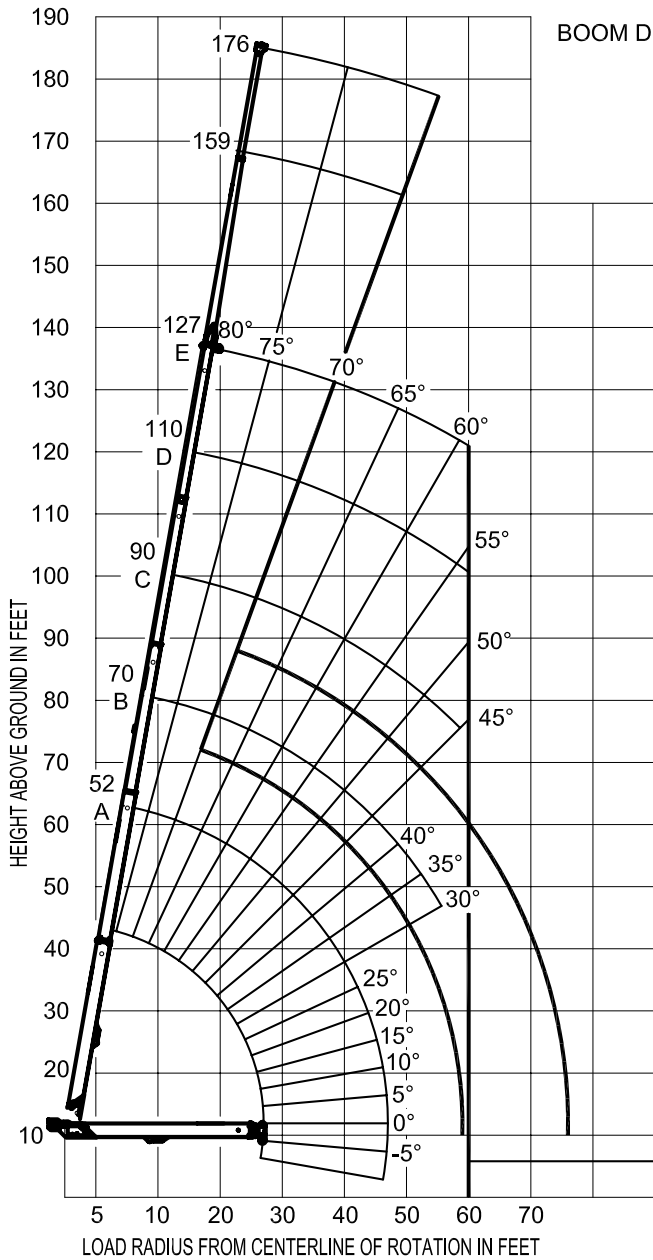

BOOM DEFLECTION NOT SHOWN

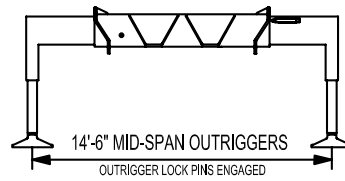

**NOTE:**

1. Operate jib by radius when main boom is fully extended. Increase boom angle if necessary to maintain load radius.
2. When boom is retracted, operate jib by boom angles. Do not exceed any rated jib capacities at reduced boom lengths.
3. Capacities do not exceed 85% stability.
4. Load ratings above bold line are structurally limited.
5. Personnel handling is allowed only with full span outriggers.
6. Boom load ratings are based on loaded boom radius. Loaded boom angles are given as reference only.

**AREA OF OPERATION:**

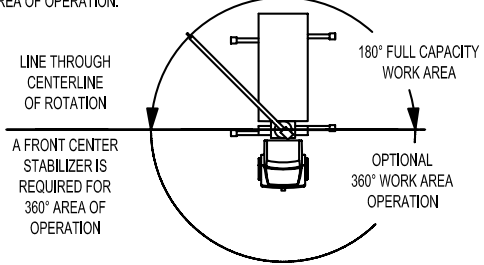

**STABILITY LIMIT LINE (NO LOAD)**

CRANE MEETS ASME B30.5 REQUIREMENTS AT TIME OF MANUFACTURE

DO NOT PAINT OVER ANY LABELS

1172320 022311



Elliott Equipment Company  
4427 South 76th Circle  
Omaha, NE 68127  
Phone: 402-592-4500  
Fax: 402-592-4553  
Email: sales@elliottequip.com

**Built for You.**  
www.elliottequip.com

**TRUCK CHASSIS SPECIFICATIONS**

	36127F BoomTruck
Wheelbase (WB)	286" / 7264 mm
Cab to Axle (CA)	200" / 5080 mm (tridem rear)
Cab to End of Frame (EOF)	320" / 8128 mm
Frame Section Modulus	30.0 in <sup>3</sup> -110,000 psi / 492 cm <sup>3</sup> -758,428 kPa
Front Axle Gross Weight Rating	20,000 lb / 9071 kg
Rear Axle Gross Weight Rating	66,000 lb / 30 000 kg
Integral Front Frame Rails	Required for Front Stabilizer

Chassis data is minimum general requirements-not for engineering.  
 Actual dimensions and truck data will depend on truck selection and axle configuration.  
 \*Minimum chassis weight is required to meet 85% stability requirements.

**OPTIONS**



**Radio Remote Control**

Interference protected radio remotes let you get closer to your work and have full control over your machine. Includes battery charging feature and optional LMI screen.

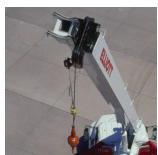

**Pin-On Jib Attachments**

Two piece telescoping jib with material handling and basket attachment capabilities. Stows on the side of the boom for easy placement while on the worksite.



**Hydraulic Oil Cooler**

Add a bed-mounted hydraulic oil cooler to assist with high duty cycle job applications.



**Automatic Safety Rotation Lockout**

“Short-jack” your BoomTruck by adding an automatic safety lockout to prevent boom movement over the side where outriggers are not fully extended.



**Tool Boxes**

Optional tool boxes and bed storage can accommodate any storage need for tools, work materials and more.

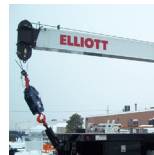

**Hook Block for Multi-Part Line**

Elliott can install a 2-3 part hook block or a 4 part-hook block to improve lifting capabilities. The block can store right on the rear of the bed.

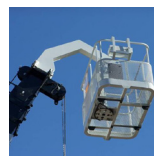

**Gravity Levelled Basket**

Elliott’s work platform pins onto the boom for easy installation and removal. Gravity leveling and mechanical rotation makes it a great accessory for any worksite.

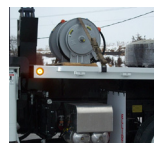

**Body Mounted Hose Reels and Circuits**

Let us work with you to customize your tool compatibility by adding hose reels or hydraulic circuits to the crane bed.