

Telescopic Truck Crane

HC 1020-2

Dimension Chart

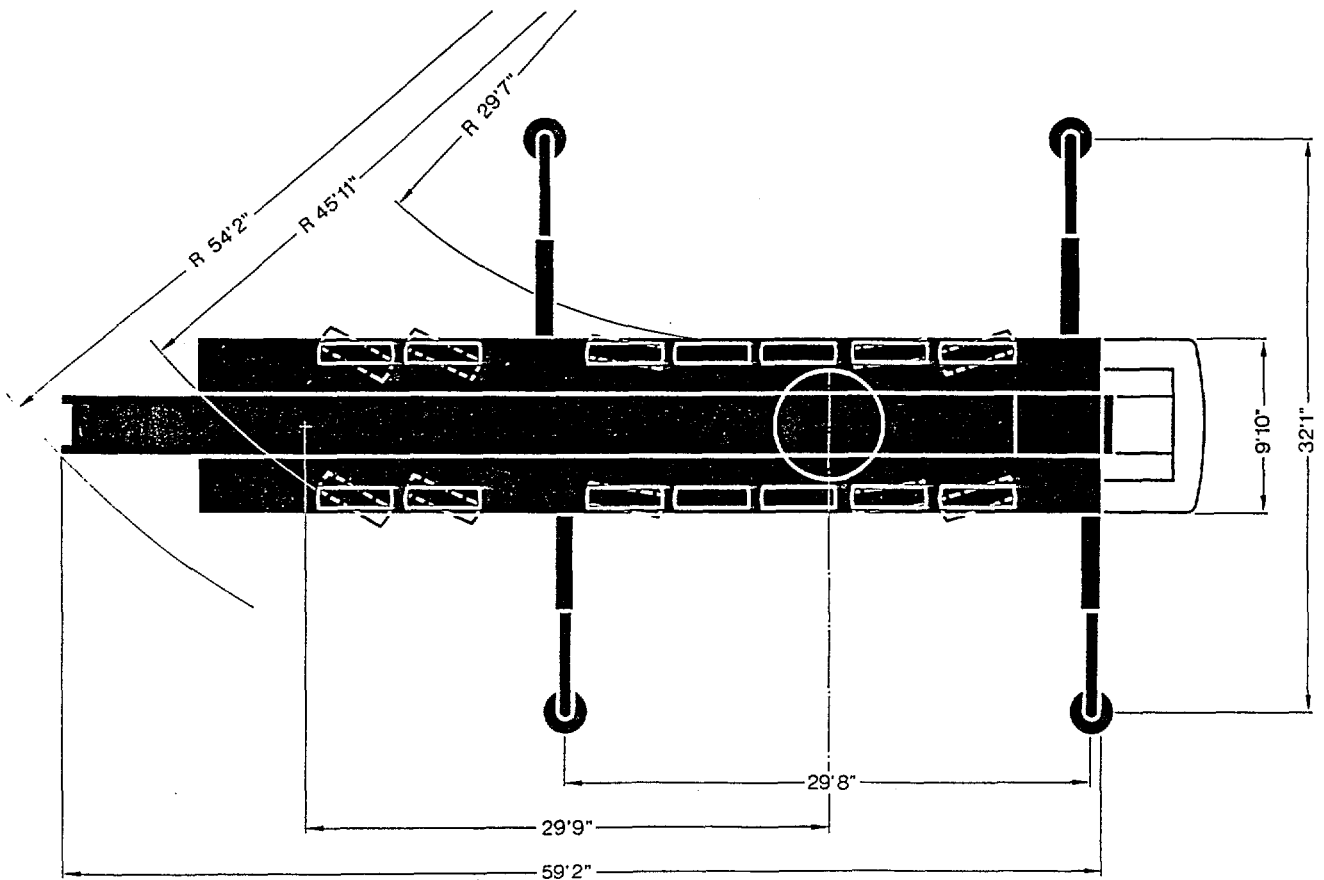
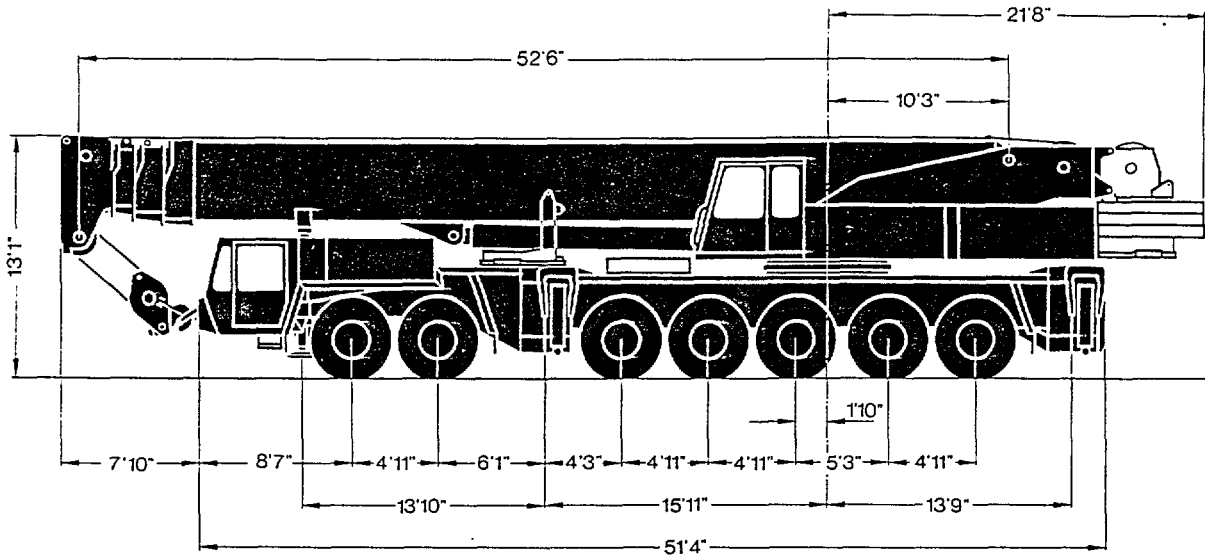

Specifications

Tail Swing

Without counterweight and 2nd hoist unit	16' 7"
With counterweight 19,000 lb and 2nd hoist unit	20' 6"
With total counterweight and 2nd hoist unit	21' 10"



Working Speeds (infinitely variable)

Units	Line Speed	Rope Pull, Single Line	Length of Hoist Rope
Main Hoist	max. 607 ft/min	27,625 lb	1,214 ft
Secondary Hoist	max. 607 ft/min	27,625 lb	1,214 ft
Swing	max. 1.0 RPM		
Telescoping from 52 ft to 171 ft	120 s		
Boom Elevation from -2° to 84°	95 s		

Carrier

Width	9' 10"
Track	8' 2"
Tavel Speed	0... 40 mph

Hook-Block/Crane Hook

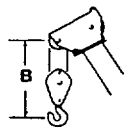

Capacity		Number of Sheaves	Number of Lines	Weight	"B"
max.	85 %				
727,000 lb	727,000 lb	13	27	6,630 lb	8 ft
441,000 lb	441,000 lb	8	16	3,978 lb	8 ft
221,000 lb	194,000 lb	3	7	2,542 lb	8 ft
88,000 lb	82,000 lb	1	3	1,680 lb	8 ft
28,000 lb	28,000 lb	Crane Hook	1	774 lb	6 ft

*required modification of boom head

Lifting Capacities with Superlift in 1,000 lb

with outriggers – 360° – 85%

176,000 lb Counterweight

Radius (ft)	Main Boom (ft)				
	52***	82	112	141	171
8	1000.0***	-	-	-	-
9	900.0***	-	-	-	-
11	637.0**	-	-	-	-
13	587.0**	-	-	-	-
15	537.0*	-	-	-	-
16	500.0*	-	-	-	-
20	425.0	362.0	255.0	180.0	-
23	375.0	350.0	240.0	175.0	-
26	330.0	330.0	235.0	170.0	-
29	295.0	300.0	225.0	165.0	-
33	270.0	275.0	215.0	160.0	99.2
39	219.0	220.0	190.0	147.0	99.2
46	-	182.0	170.0	137.0	99.2
52	-	152.2	155.0	125.0	99.2
59	-	132.0	132.0	115.0	95.0
66	-	112.0	117.0	102.0	90.0
72	-	-	100.0	92.5	85.0
79	-	-	87.5	85.0	77.5
85	-	-	75.0	75.0	71.2
92	-	-	68.5	67.5	63.7
98	-	-	61.5	61.5	56.2
105	-	-	-	55.5	52.5
112	-	-	-	50.5	47.5
118	-	-	-	45.0	45.0
125	-	-	-	41.0	41.0
131	-	-	-	-	37.0
138	-	-	-	-	33.5
144	-	-	-	-	29.2
151	-	-	-	-	27.5

110,000 lb Counterweight

Radius (ft)	Main Boom (ft)				
	52***	82	112	141	171
8	-	-	-	-	-
9	727.0**	-	-	-	-
11	637.0**	-	-	-	-
13	587.0**	-	-	-	-
15	537.0*	-	-	-	-
16	500.0*	-	-	-	-
20	422.0	362.0	255.0	180.0	-
23	352.0	350.0	240.0	175.0	-
26	302.0	300.0	235.0	170.0	-
29	262.0	259.0	225.0	165.0	-
33	232.0	230.0	215.0	160.0	99.2
39	187.0	184.0	185.0	147.0	99.2
46	-	141.7	148.0	137.1	99.2
52	-	113.0	118.0	119.0	99.2
59	-	91.9	96.9	98.4	95.0
66	-	76.7	81.2	82.4	82.4
72	-	-	69.2	70.2	70.2
79	-	-	59.4	60.4	60.4
85	-	-	51.7	52.4	52.4
92	-	-	45.2	45.7	45.7
98	-	-	39.7	39.9	39.9
105	-	-	-	34.9	34.9
112	-	-	-	30.4	30.4
118	-	-	-	26.7	26.7
125	-	-	-	23.4	23.4
131	-	-	-	-	20.4
138	-	-	-	-	17.9
144	-	-	-	-	15.7
151	-	-	-	-	13.4

*** 1000.0 lb at 8ft Radius represents max. static test load only
 *** without SUPERLIFT-Suspension
 ** Only 2 x 10° over side (required add. attachment)
 * required add. attachment (max. Load 445,000 lb with 16 Lines)

176,000 lb Counterweight (on Main Boom 171 ft)

Foldaway Extension					Fixed Jib									
Radius (ft)	39 ft		66 ft		Radius (ft)	59 ft		79 ft		98 ft		118 ft		Radius (ft)
	0°	15°	0°	15°		3°	20°	3°	20°	3°	20°	3°	20°	
39	50.0	-	26.2	-	39	47.6	-	-	-	-	-	-	-	39
46	50.0	36.7	25.2	-	46	45.2	29.5	38.3	-	-	-	-	-	46
52	48.4	34.7	24.3	20.0	52	42.7	27.5	35.2	-	27.6	-	-	-	52
59	46.9	32.7	23.4	19.0	59	40.5	26.0	33.0	-	26.5	-	20.9	-	59
66	44.9	31.5	22.4	18.2	66	38.1	24.4	31.1	18.5	24.9	-	19.8	-	66
72	42.7	29.7	21.7	17.7	72	36.1	22.9	29.1	17.4	23.6	-	18.5	-	72
79	40.4	28.0	20.7	17.0	79	34.1	21.6	27.3	16.3	22.5	13.4	17.6	-	79
85	38.4	26.7	19.9	16.3	85	32.1	20.5	25.8	15.2	21.1	13.0	16.5	-	85
92	35.7	25.2	19.2	15.7	92	30.2	19.2	24.5	14.3	19.8	12.5	15.8	10.8	92
98	33.2	24.0	18.5	15.2	98	28.2	18.0	23.1	13.4	18.5	12.1	14.8	10.3	98
105	31.2	22.7	17.6	14.5	105	26.4	16.9	21.6	12.5	17.6	11.4	14.1	9.9	105
112	29.5	21.5	16.7	14.0	112	24.7	16.1	20.3	11.9	16.3	11.0	13.4	9.4	112
118	26.9	20.5	16.0	13.5	118	22.9	15.0	19.0	11.2	15.4	10.3	12.3	9.0	118
125	25.5	19.2	15.3	13.0	125	21.1	13.9	17.8	10.5	12.5	9.7	11.7	8.6	125
131	22.7	18.2	14.7	12.5	131	19.6	13.0	16.5	9.9	13.2	9.0	10.6	7.9	131
138	20.0	17.0	13.9	12.0	138	18.0	12.1	15.6	9.2	12.3	8.6	9.9	7.5	138
144	18.2	16.0	13.2	11.5	144	16.5	11.2	14.5	8.6	11.9	8.1	9.0	7.0	144
151	16.5	15.0	12.6	11.1	151	15.4	10.3	13.6	8.1	11.0	7.5	8.4	6.4	151
157	15.0	14.0	12.0	10.7	157	14.1	9.7	12.5	7.7	10.6	7.0	7.7	5.9	157
164	14.0	13.2	11.5	10.2	164	13.2	9.0	11.6	7.0	9.9	6.6	6.8	5.5	164
170	-	12.2	11.0	9.7	170	12.1	8.3	10.8	6.6	8.8	6.1	6.0	5.0	170
177	-	11.2	10.5	9.2	177	11.0	6.8	9.9	6.1	7.9	5.7	5.3	4.6	177
183	-	-	10.0	9.0	183	9.5	5.2	9.0	5.7	7.0	5.3	4.7	4.2	183
190	-	-	9.5	8.7	190	8.1	3.9	8.1	5.2	6.2	4.8	4.2	3.7	190
197	-	-	9.0	8.3	197	-	-	7.0	3.7	5.2	4.4	3.4	3.3	197

Working Ranges

– Main boom
 – Foldaway extension

52 ft – 171 ft
 39 ft – 66 ft

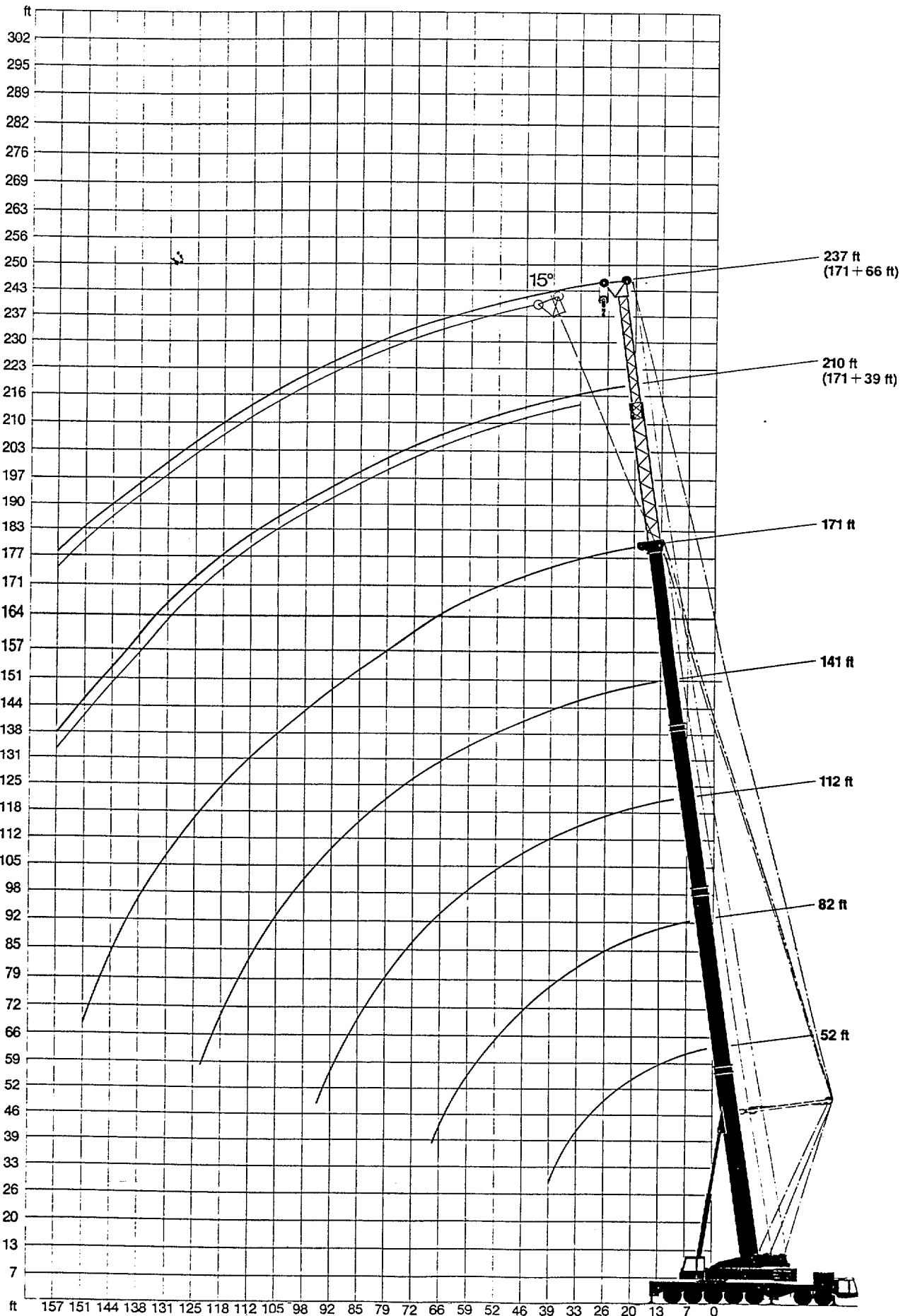

Lifting Capacities without Superlift in 1,000 lb

with outriggers – 360° – 85 %

48,500 lb Counterweight

Radius (ft)	Main Boom (ft)				
	52	82	112	141	171
11	575.0**	-	-	-	-
13	539.0**	384.0	-	-	-
15	469.0**	374.8	-	-	-
16	412.0	361.5	265.0	-	-
20	332.0	329.0	240.3	172.0	-
23	277.0	274.0	218.2	161.0	-
26	236.0	234.0	205.0	147.7	-
29	205.0	202.0	191.8	138.8	92.6
33	100.0	170.0	177.0	130.0	92.6
39	129.0	124.0	131.0	114.6	85.9
46	-	93.4	99.6	99.6	77.1
52	-	72.7	78.2	78.2	70.5
59	-	58.2	63.2	63.2	63.2
66	-	47.2	51.9	51.9	51.9
72	-	-	43.2	43.2	43.2
79	-	-	35.9	35.9	35.9
85	-	-	29.9	24.9	24.9
92	-	-	25.2	24.9	24.9
98	-	-	21.2	20.7	20.7
105	-	-	-	16.9	16.9
112	-	-	-	13.9	13.9
118	-	-	-	11.4	11.4
125	-	-	-	9.2	8.9
131	-	-	-	-	6.7

** Only 2 x 10° over side (required add. attachment (max. Load 445,000 lb on 16 falls))

48,500 lb Counterweight

Radius (ft)	Main Boom (ft) – unpinned				
	52	82	112	141	171
11	575.0**	-	-	-	-
13	539.0**	110.2	-	-	-
15	469.0**	110.2	-	-	-
16	412.0	110.2	110.2	-	-
20	332.0	110.2	110.2	110.2	-
23	277.0	110.2	110.2	110.2	-
26	236.0	110.2	110.2	110.2	-
29	205.0	110.2	110.2	110.2	66.1
33	180.0	110.2	110.2	110.2	66.1
39	129.0	110.2	110.2	110.2	66.1
46	-	93.4	99.6	99.6	66.1
52	-	72.7	78.2	78.2	66.1
59	-	58.2	63.2	63.2	63.2
66	-	47.2	51.9	51.9	51.9
72	-	-	43.2	43.2	43.2
79	-	-	35.9	35.9	35.9
85	-	-	29.9	29.9	29.9
92	-	-	25.2	24.9	24.9
98	-	-	21.2	20.7	20.7
105	-	-	-	16.9	16.9
112	-	-	-	13.9	13.9
118	-	-	-	11.4	11.4
125	-	-	-	9.2	8.9
131	-	-	-	-	6.7

19,000 lb Counterweight

Radius (ft)	Main Boom (ft)				
	52	82	112	141	171
11	440.0*	-	-	-	-
13	440.0*	340.0	-	-	-
15	379.1	330.6	-	-	-
16	335.0	319.6	234.0	-	-
20	268.9	266.7	213.8	152.1	-
23	222.6	220.4	194.0	142.1	-
26	190.4	188.0	181.8	132.2	-
29	156.3	151.8	160.0	123.4	88.0
33	125.2	121.2	128.3	115.7	86.8
39	87.3	83.3	89.5	89.5	77.1
46	-	61.0	66.5	66.5	66.5
52	-	46.5	51.1	51.1	51.1
59	-	35.7	40.5	40.5	40.5
66	-	27.7	32.1	32.1	32.1
72	-	-	25.5	25.5	25.5
79	-	-	20.5	20.2	20.2
85	-	-	16.3	16.0	16.0
92	-	-	12.7	12.5	12.5
98	-	-	10.1	9.4	9.4
105	-	-	-	7.2	7.0
111	-	-	-	4.8	4.8

0 lb Counterweight

Radius (ft)	Main Boom (ft)				
	52	82	112	141	171
11	440.0*	-	-	-	-
13	414.4*	340.0	-	-	-
15	357.1	330.6	-	-	-
16	315.2	313.0	234.0	-	-
20	253.5	251.3	213.8	152.0	-
23	210.5	208.3	194.0	142.1	-
26	169.3	164.4	173.9	132.2	-
29	128.9	124.7	132.7	123.4	88.0
33	102.7	98.7	105.8	105.8	86.8
39	70.5	66.5	72.7	72.7	72.7
46	-	47.8	53.1	53.1	53.1
52	-	34.8	40.1	40.1	40.1
59	-	25.5	30.6	30.6	30.6
66	-	18.7	23.3	23.3	23.3
72	-	-	17.8	17.8	17.8
79	-	-	13.4	13.4	13.4
85	-	-	9.9	9.7	9.7
92	-	-	7.0	6.6	6.6
98	-	-	4.6	4.1	4.1

* required add. attachment (max. Load 445,000 lb on 16 falls)

Working Ranges

- Main boom
- Fixed fly jib

52 ft - 171 ft
 59 ft, 79 ft, 98 ft, 118 ft

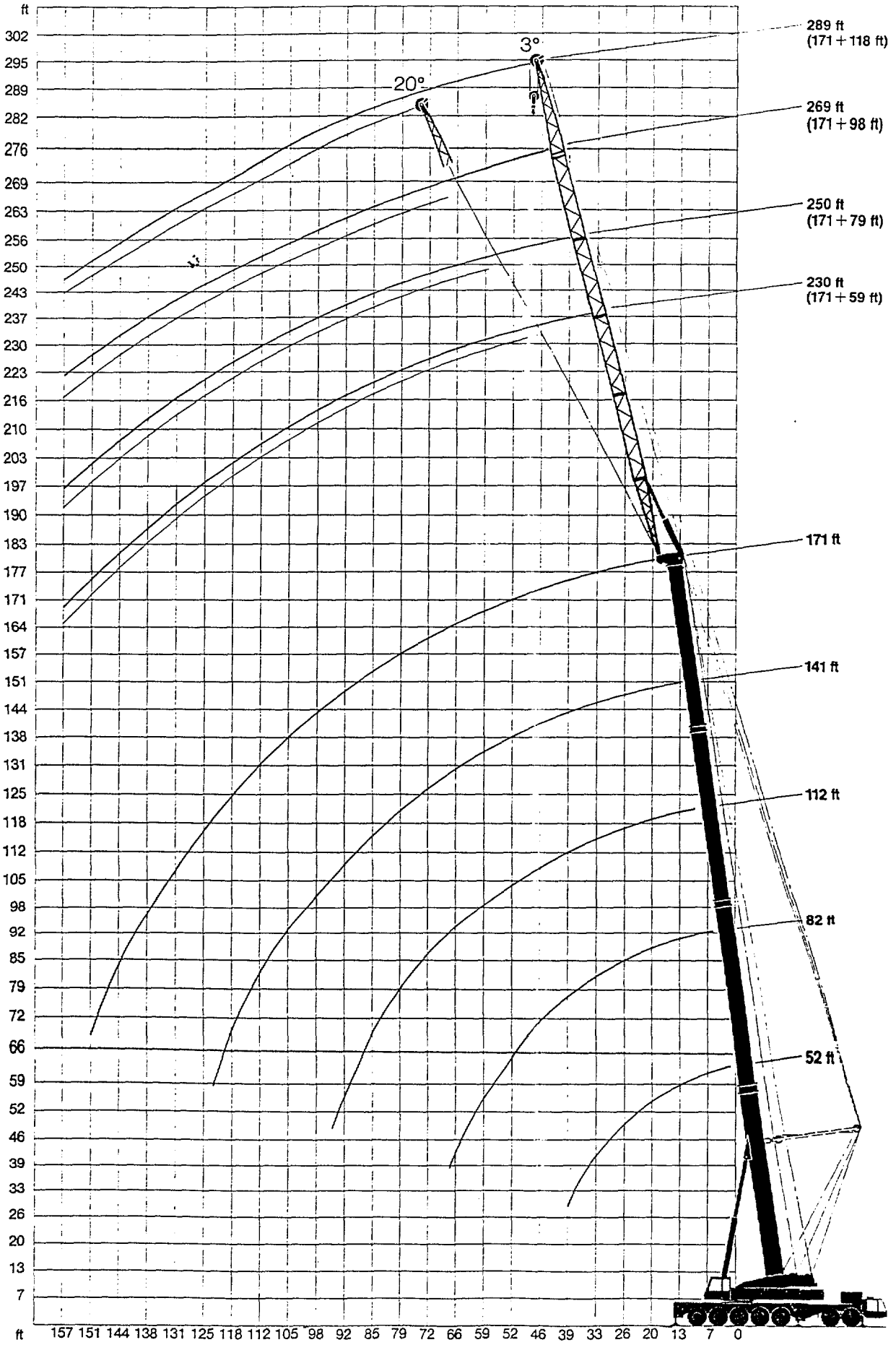

Lifting Capacities on Luffing Fly Jib in 1,000 lb

with outriggers – 360° – 75%

110,000 lb Counterweight

Boom (ft)	Radius (ft)	Luffing Fly Jib (ft)						
		59	79	98	118	138	157	177
82	33	170.0	154.0	110.2	–	–	–	–
	39	154.0	148.0	110.2	88.0	–	–	–
	46	132.0	138.0	110.2	88.0	72.7	–	–
	52	101.0	120.0	110.2	88.0	71.0	51.8	40.8
	59	–	105.0	108.6	88.0	67.9	49.2	38.8
	66	–	92.1	94.5	86.0	65.4	46.3	36.3
	72	–	–	83.3	83.7	62.0	42.8	34.1
	79	–	–	74.2	75.4	60.0	41.4	31.9
	85	–	–	63.9	67.7	57.3	39.2	30.2
	92	–	–	51.0	61.3	54.4	37.0	28.4
	98	–	–	–	55.3	51.8	35.2	26.9
	112	–	–	–	–	46.5	31.7	24.0
	125	–	–	–	–	35.9	28.6	22.0
	138	–	–	–	–	–	22.5	18.7
151	–	–	–	–	–	–	16.5	
164	–	–	–	–	–	–	14.3	
112	33	110.0	85.0	–	–	–	–	–
	39	108.0	82.0	68.3	–	–	–	–
	46	105.8	79.3	66.1	55.1	–	–	–
	52	103.6	77.1	64.1	54.0	44.0	35.2	–
	59	–	75.8	62.6	53.6	42.7	34.8	28.4
	66	–	75.6	61.7	53.3	42.5	34.6	28.2
	72	–	75.6	61.7	52.2	42.3	34.4	27.5
	79	–	66.1	61.7	51.3	42.1	34.1	26.6
	85	–	–	61.3	50.9	41.9	34.1	26.0
	92	–	–	60.2	50.7	41.4	33.3	25.3
	98	–	–	–	50.7	41.0	32.4	24.2
	112	–	–	–	44.7	39.9	30.8	22.0
	125	–	–	–	–	38.3	28.6	19.8
	138	–	–	–	–	–	25.3	17.8
151	–	–	–	–	–	–	15.6	
164	–	–	–	–	–	–	13.6	
141	39	–	54.0	43.0	–	–	–	–
	46	–	53.6	41.4	35.3	–	–	–
	52	–	53.3	41.0	34.2	27.5	–	–
	59	–	53.3	40.8	33.7	27.3	22.7	–
	66	–	53.3	40.8	33.3	27.1	22.5	17.6
	72	–	53.3	40.8	33.0	26.9	22.2	17.6
	79	–	53.3	40.8	33.0	26.6	22.0	17.2
	85	–	–	40.8	33.0	26.6	21.8	17.2
	92	–	–	40.8	33.0	26.6	21.6	17.2
	98	–	–	–	33.0	26.6	21.4	17.2
	112	–	–	–	33.0	26.6	21.4	17.2
	125	–	–	–	–	26.6	21.4	17.2
	138	–	–	–	–	26.6	21.4	16.5
	151	–	–	–	–	–	21.4	14.5
164	–	–	–	–	–	–	12.1	
171	46	–	–	29.1	–	–	–	–
	52	–	–	28.0	25.3	–	–	–
	59	–	–	27.5	25.1	18.7	–	–
	66	–	–	27.5	24.9	18.3	14.3	11.0
	72	–	–	27.5	24.7	18.0	14.1	11.0
	79	–	–	27.5	24.5	17.8	13.9	10.6
	85	–	–	27.5	24.2	17.6	13.6	10.3
	92	–	–	27.5	23.8	17.6	13.4	9.9
	98	–	–	–	23.1	17.6	13.4	9.9
	112	–	–	–	22.0	17.6	13.4	9.9
	125	–	–	–	–	17.6	13.4	9.9
138	–	–	–	–	17.6	13.4	9.9	
151	–	–	–	–	–	13.4	9.9	
164	–	–	–	–	–	–	9.9	

Lifting Capacity Notes

Lifting capacities do not exceed 85% of tipping load resp. 75% of tipping load on luffing fly jib. Max. wind speed: 50.85 ft/sec or 35 mph. Crane operation up to a wind force of 5% Beaufort scale (29.5 ft/sec or 20 mph) permissible. The weights of all load-handling devices are considered part of the load, and suitable allowance for them should be made.

All capacities above the parting line are based on structural strength. The capacities below the parting line are based on stability for the percentage of tipping load indicated.

Working Ranges

– luffing jib: 59 ft, 79 ft, 98 ft, 118 ft, 138 ft, 157 ft, 177 ft

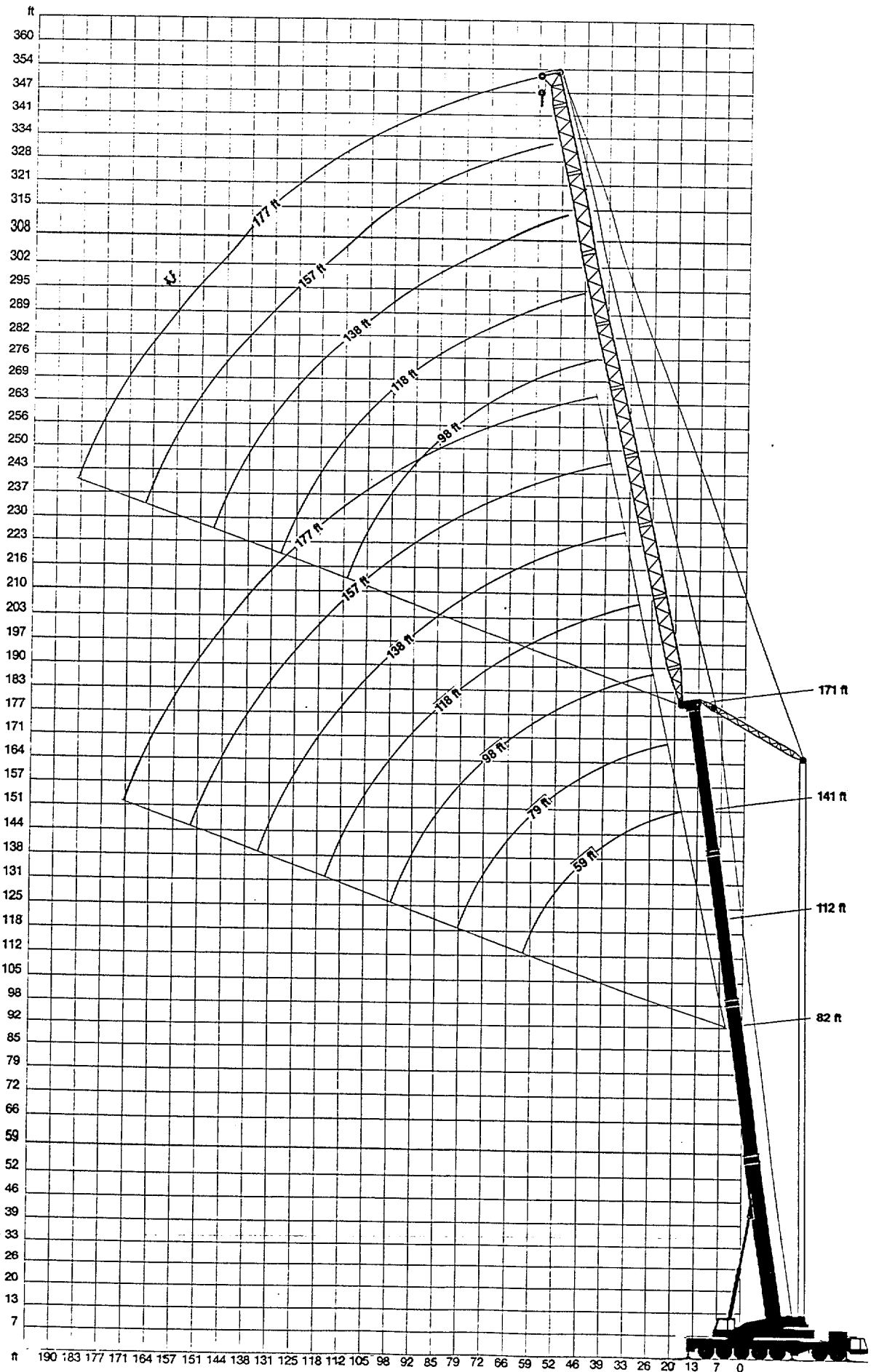

Carrier

Truck-Type Carrier	Demag. 14x6 drive.
Frame	Specially designed main frame of closed box-type construction, fabricated from high-grade close-grain steel, with outrigger boxes integral.
Outriggers	Four hydraulically operated outriggers with telescopic beams and jack legs plus front outrigger jack for 360° crane operation.
Engine	Daimler-Benz OM-424 A water-cooled 12-cylinder Diesel Engine. Output acc. SAE J 1349: gross 413 kW (562 hp). Fuel-Tank Capacity: 133 gallons.
Transmission	Allison automatic transmission.
Axles	Hydro-pneumatic spring suspension. Planetary axles: 1st, 4th, 5th. Steering axles: 1st, 2nd, 3rd, 6th, 7th.
Wheels	Single tyres 14.00 R 24, PR 22 on rims 10.0-24.
Steering	ZF semibloc mechanical steering with hydraulic booster.
Brakes	U.S. Acc. to C standards.
Electrical Equipment	24-volt system, DC.
Cab	Rubber-mounted low-line two-man all-steel cab.

Superstructure

Upper Frame	Demag-built weldment of high-grade close-grain steel.
Paneling	Sectional side panels which are removable for service accessibility.
Swing Bearing	Triple-row roller bearing with external ring gear integral.
Engine	Daimler-Benz OM-421 water-cooled 6-cylinder Diesel Engine. Output acc. SAE J 1349: gross 169 kW (230 hp). Fuel-Tank Capacity: 76 gallons.
Hydraulic System	2 variable-displacement axial-piston pumps with automatic power control and 1 fixed-displacement tandem pump. Three independent crane motions. 1 fixed-displacement pump for low-pressure servo control.
Hoist Unit	Variable-displacement axial-piston hydraulic motor with planetary reduction and spring-loaded multiple-disk brake in hoist drum. Non-rotating rope.
Swing	Axial-piston hydraulic motor with planetary reduction integral. Foot-operated service brake and spring-loaded holding brake.
Boom Elevation	Two hydraulic cylinders with pilot-controlled braking valve for lowering.
Control	Self-centering levers control, all crane functions by power assisted servo valves.
Cab	Comfortable all-steel cab with sliding door, large folding-out front window, roof window, hot-air heating and ventilation system. The cab is hydraulically tiltable to an angle of 15°.
Boom	Four-section power-telescoping boom, fabricated from high-grade close-grain plate stock, featuring the familiar DEMAG "ovaloid" design of rectangular box members with rounded-off corners. Each center section slides on diagonally self-centering plastic shoes. Boom head with mounting lugs for extension boom and luffing jib boom. Telescope pin-locked system.
Counterweight	110,000 lb standard.
Safety Devices	Standard equipment are: electronic overload cut-out (load-moment limiting device) with digital read-out for hook load, rated load, boom length, boom angle, load radius; monitoring devices to assist in trouble shooting; analog display to indicate the capacity utilization; limit switches on hoist and lowering motions; pressure-relief and safety holding valves.

Optional Equipment

Superlift Attachment

The Superlift attachment is a simple means to increase the load moment and the lifting capacity of the standard crane. It consists of a boom-suspension mast with guy ropes, automatically rope-length adjustment for boom telescoping. The suspension mast is lowered to the main boom when not needed, or for road transport.

Add. counterweight

66,000 lb for use with or w/o superlift.

2nd Hoist Unit (removable)

Variable-displacement axial-piston hydraulic motor with planetary reduction and spring-loaded multiple-disk brake in hoist drum. Non-rotating rope.

Boom extension

1. Fold-away 2-part lattice typ, 39 ft – 66 ft length. Adapter for 0° and 15° offset to main boom.
2. Fixed jib of 59 ft, 79 ft, 98 ft, 118 ft length (foot-, head-section and inserts from luffing jib). Equipment for 3° and 20° offset to main boom.

Luffing Jib

59 ft to 177 ft length, with luffing mast, guy ropes, electrical equipment, and safety devices (the 2nd hoist unit is necessary to use the luffing jib).

Dolly

3-axle dolly with connecting equipment for boom. Control installation for road travel.