

## GENERAL DIMENSIONS

Unit : mm

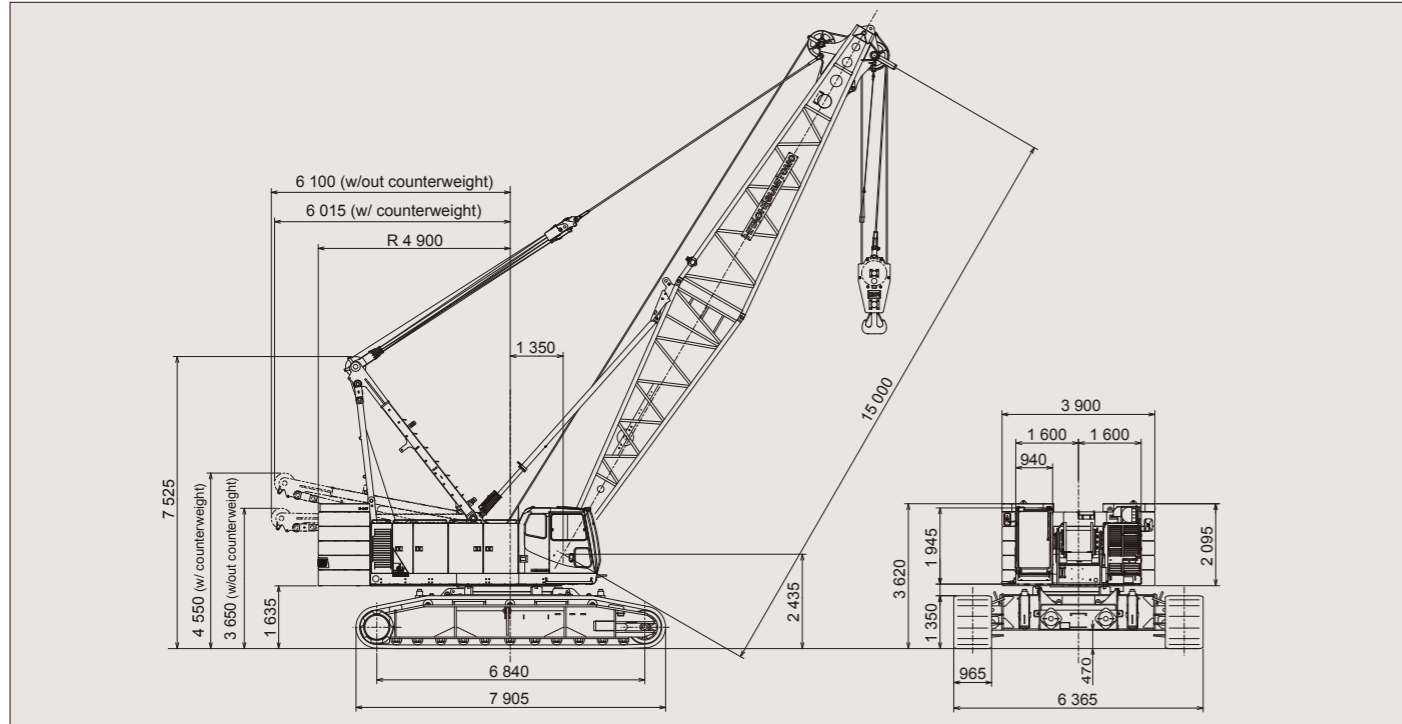

## SPECIFICATIONS

		Lift crane application	Clamshell application
Max. lifting capacity	t × m	120 × 5.0	—
Basic boom length	m	15	15
Max. boom length	m	72	27
Rope line speeds <sup>(*)1</sup>	Front main drum	m/min	110
	Rear main drum	m/min	110
	Boom hoist drum	m/min	46
Slewing speed	min <sup>-1</sup> (rpm)	1.9 (1.9)	1.9 (1.9)
Travel speed high/low <sup>(*)2</sup>	km/h	1.7 / 1.0	1.7 / 1.0
Gradeability	% (°)	30 (17)	30 (17)
Engine	Make & model	Mitsubishi 6M70-TL	Mitsubishi 6M70-TL
	Rated output	kW/min <sup>-1</sup> (PS/rpm)	272 / 2 000 (370 / 2 000)
Ground contact pressure	kPa(kgf/cm <sup>2</sup> )	97 (0.99)	100 (1.02)
Operating weight	t	131 (w / basic boom and 120 t hook block)	134 (w / basic boom and 3.0 m <sup>3</sup> clamshell bucket)

Notes : 1. These figures are based on drum first layer and rated engine rpm with no load, and vary under load and operating conditions (\*1).  
2. Travel speed is based on flat, level and firm supporting surface, and under the conditions that no load must be applied and front-end attachment must be 15 m basic boom (\*2).

!We are constantly improving our products and therefore reserve the right to change designs and specifications without notice.  
!Units in this catalog are shown under International System of Unit ; the figures in parenthesis are under Gravitational System of Units as old one.  
!Illustrations may include optional equipment and accessories, and may not include all standard equipment.

Address inquires to :

### Hitachi Sumitomo Heavy Industries Construction Crane Co., Ltd.

9-3, Higashi-Ueno 6-chome, Taito-ku, Tokyo 110-0015, Japan  
Phone: 81-3-3845-1387 Facsimile: 81-3-3845-1394  
<http://www.hsc-crane.com>

HYDRAULIC HEAVY DUTY CRAWLER CRANE

# SCX1200HD-2

The New World Standard Crawler Crane



# Flexibility

Power and Response to Spare

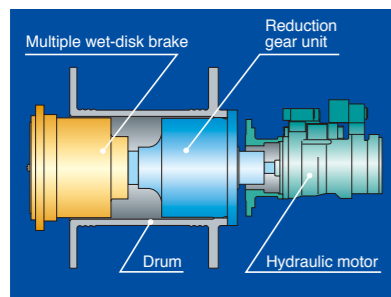

## Most advanced clutchless multiple wet-disc brake

At operator's will, two main winch drum brakes will perform a constant brake pedal feeling regardless of what is load, light or heavy, and what brake pedal stroke is done from initial thru full. And, no over-heating is of course seen even heavy duty works as a forced-oil cooling system is designed, and it results in stress-free operation.

## Free-fall mechanism

Of course, two main winch drums' free-fall function is standardized, and their rated line pull is 132 kN (13.5 ton) with 28 mm dia. cable as enough for bucket off-ground and casing tube drawing.

## Ample specifications, wide drum and high-speed line speed

The wide drum enables a single layer of cable to be 41 m (21 rows). This prevents the wear that occurs when multiple layer winding is used. And the maximum line speed of 110 meters per minute dramatically reduces operating time.

## An optional 3rd winch drum

The rated line pull of 3rd winch drum is 108 kN (11.0 ton) and has a maximum lifting capacity of 80 ton.



## Separated oil cooler from engine radiator

## High power engine

A 272 kW (370 PS) engine from Mitsubishi is provided, and accordingly a bigger drum horse power (line pull by line speed) is realized under a new winch drum design with a specially-tailored power increase control system that maximizes engine output under any load condition in whole range of engine rpm.

# Easy operation

Total Control in Total Comfort



## One-hand acceleration grip

Thanks to a unique grip design, an easy -precise- minute control of engine rpm and pump discharge from min. thru max. is really possible at the same time by simply twisting the grip fitted on slewing control lever.

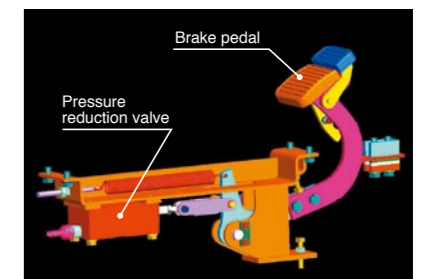

## Negative brake system

With a new negative brake of spring-applied/power hydraulically-released design applying dynamic hydraulic pressure for its release control, an effective braking can be done under an extreme light foot pedalling, and it accordingly results in greatly reducing operator fatigue especially during winch free-fall operations under duty cycle applications. Further, the use of negative brake system maintains a high level of brake safety even if a hydraulic pressure drop in the circuit happens.

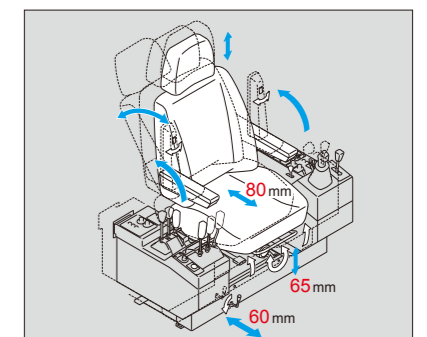

## Slidable control station and operator seat

Power to spare for foundation  
and civil engineering operations

# Tough

The all new SCX1200HD-2 is  
ready to meet the needs of  
the heavy-duty market.

The reinforced body and powerful  
winch provide the extra operability,  
durability and safety that will take  
the lead in this market.

The SCX1200HD-2 can easily handle  
Ø3,000 mm class hammer  
grab bucket or the main unit of  
a casing driver and answer almost  
any need for foundation  
and civil engineering work.



**Advanced clutchless  
multiple wet-disc brake**

**Rated line pull:  
132 kN (13.5 ton)**

**Bigger root dia. drum:  
624 mm**

**High line speed:  
110 m/min<sup>-1</sup>**

**High power engine:  
272 kW (370 PS)**

Notes: Illustrations and photos may include optional equipment and accessories, and may not include all standard equipment.  
: All of photos shown in this catalog are for the sake of catalog make; if the operator is away from cab during  
machine operation, it is certainly required to set appropriate safety device(s) without fail.

# Reliable

Safety and Environmentally Friendly Features.

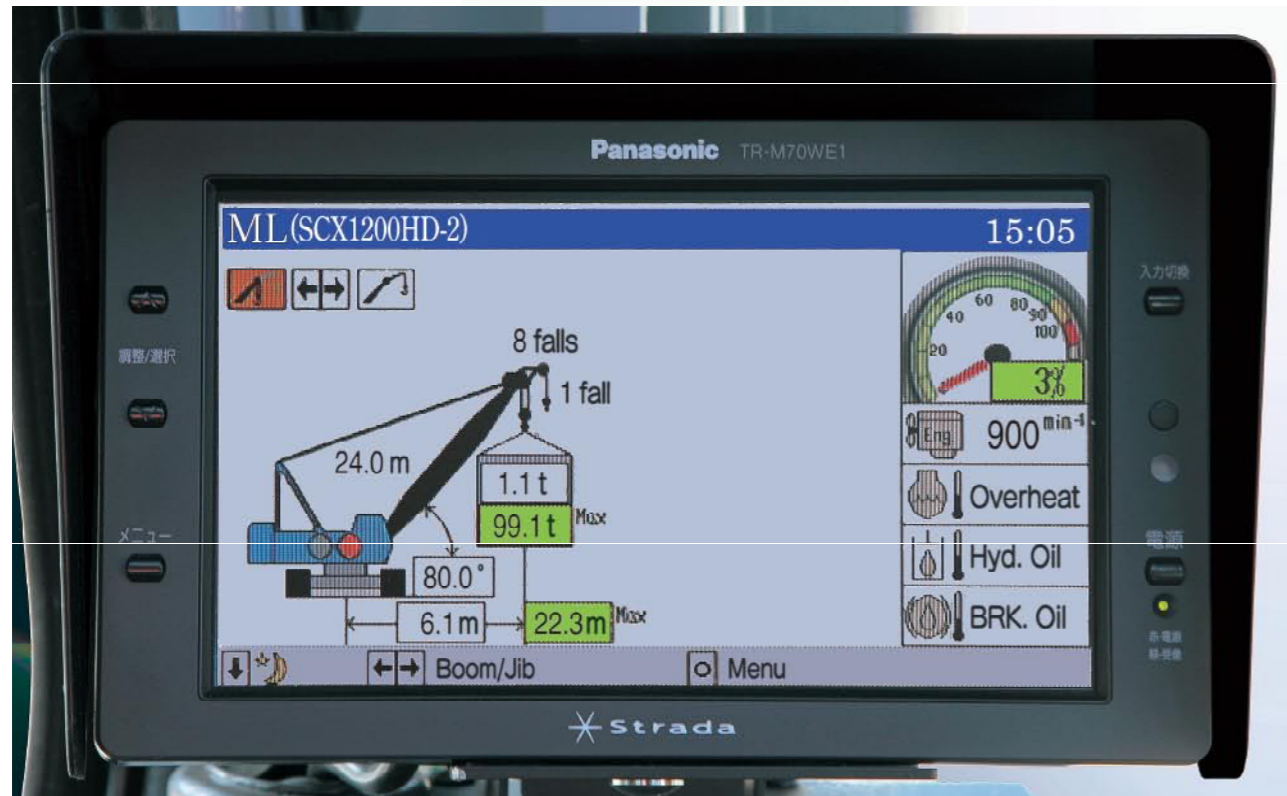

## New load moment indicator

An easy-to-read LCD graphic display panel is well designed and a reflection-less display panel is provided on a new LMI with setting ease of viewing angle. In addition, no zero-point adjustment, and data input thru interface counter-indication/message on display panel are available for easier and certain setting of operating conditions and LMI function. Of course, "present lifting load", "rated load", "load ratio", "working radius", "boom angle", "engine rpm" and so on are indicated on the LMI display panel. Further, the LMI functions that if lifting condition reaches peril zone, an intermittent warning buzzer is given operator together with a warning letter message on display panel of LMI.

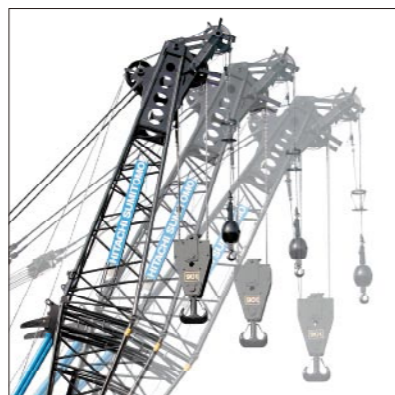

## Boom speed slowdown function



## Brake mode change switches

On top of winch drum control levers, the said switches are fitted too for easy-and-sure change of brake mode from "automatic" to "free-fall" and vice versa.

## Drum rotation sensors

Control levers of two main and boom hoist drums each fit the drum rotation sensor to let operator sense a drum rotation speed decrease/increase by a knob vibration during inching lever operation, and it results in realizing a good work performance on specific foundation jobs like "bucket off-ground", "pile initial drawing" and so on, and in performing more safety lifting works, especially in blind condition.

- Automatic drum lock: boom hoist drum
- Emergency engine stop switch (in cab)
- Slewing & travel alarm

## Low emission engine

The prime mover, Mitsubishi 6M70-TL, meets Stage/Tier 3 of current emission regulation for off-road diesel engine in Europe, USA, and Japan.

# Speedy

Simple Disassembly and Assembly Make Transporting Easy



## Counterweights

"Hook-on" design is taken for their mounting on upper revolving frame, and "horizontally-split" design is also taken to load boom extension(s) onto counterweights when transport.

## Folding A-frame with lifting/lowering cylinder enables high-speed disassembly and assembly

The cylinder for lifting/lowering the A-frame is standard equipment. This enables quick assembly and disassembly for enhanced efficiency.

## Optional rigid guard

A detachable-ease rigid guard is optionally available i/o standard, and it is possible to eliminate to take cable out of drum when machine disassembling for transport in the case of a special cable-end with lug.

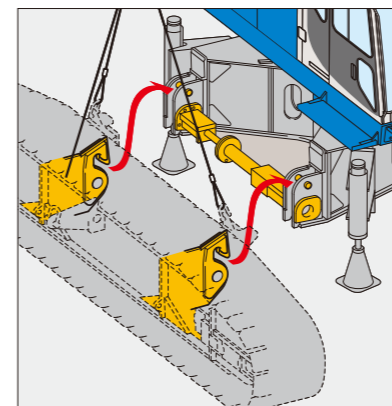

## Only cylinder operation is needed for side frame assembly

The old-type insert-type method meant it took a lot of time to assembly the main body and side frame. The new-type cylinder-joint method enables the main body and side frame to be fixed in place by only operating the cylinder. Assembly only takes as long as the time needed to extend and retract the cylinder.



## Easy to load onto trailer

Since the jack cylinder can be stored in the lower frame, the main body can be loaded directly on the trailer without using any wooden beams.

\* Note that this may not be possible on some trailers.

