



Custom Built Marine & Offshore Cranes

FULLY FOLDABLE CRANE

HLM 10-3S MODEL

TECHNICAL SPECIFICATION

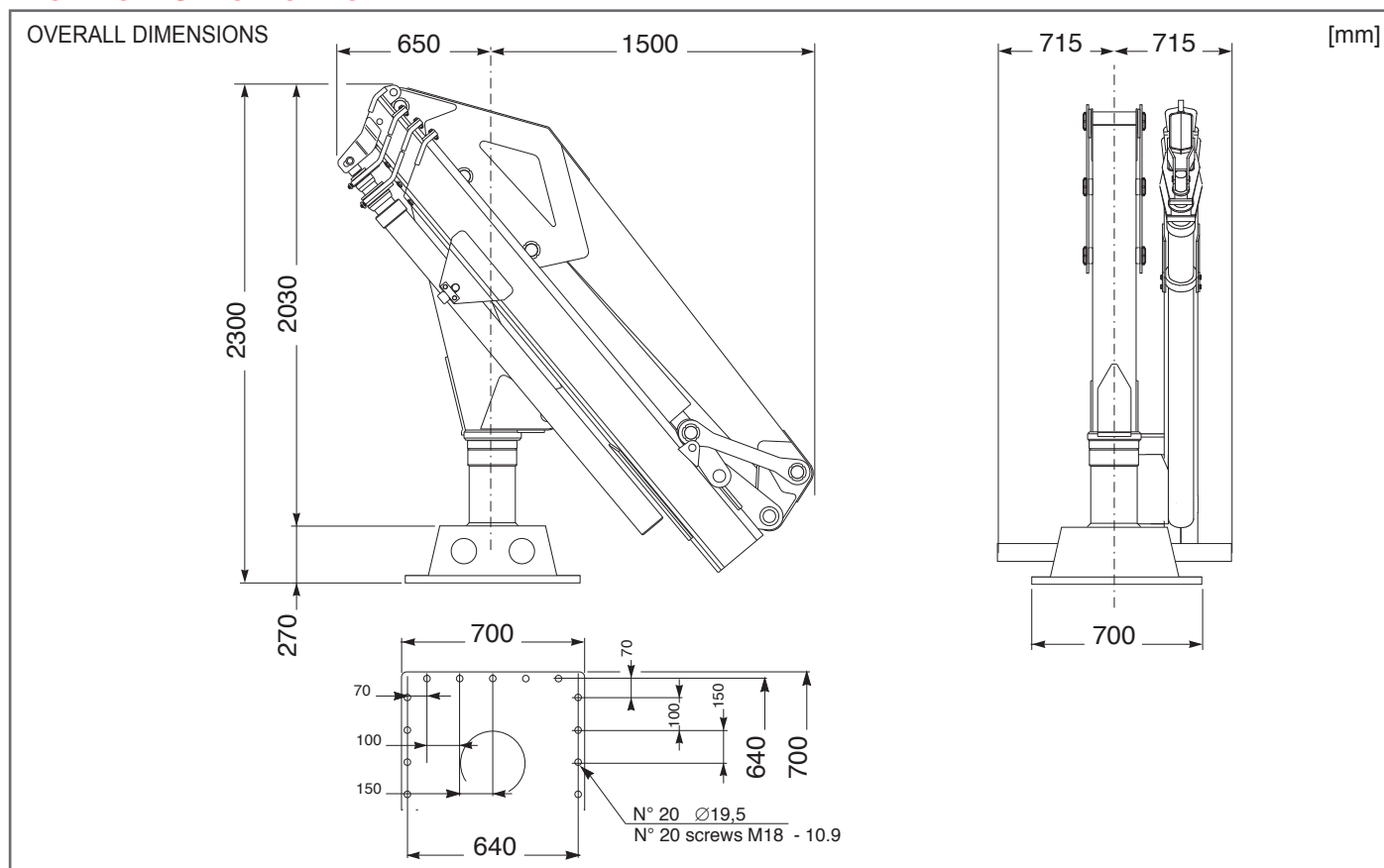

TECHNICAL DATA					
Hydraulic extensions	N°	3	Empty weight of the crane	kg	1710
Net lifting moment	t-m	10	Recommended amount of oil	lt	100
Slewing torque	kg-m	1300	Slewing speed	rpm	1,2
Slewing angle (continuous)	°	380	Main boom lifting time	sec	19
Pump capacity	lt/min	30	Secondary boom articulation time	sec	20
Max working pressure	bar	220	Boom element extension time	sec	55
STANDARD FEATURES			AVAILABLE OPTIONS		
			1 ton direct pull winch rope Ø 8		
			Sheave block with Ø180 pulley		
			Winch limit switch		
			Load limiting device		
			Size 3 electrohydraulic power pack (HP20)		
			Off-machine distributor control		
			1st manual extension 0,60 ton @ 12,35 m		
			2nd manual extension 0,43 ton @ 14,38 m		

October 2014

HLM10-3S Rev.00

The technical data contained in this card are only indicative and can be changed without notice.

HEILA CRANES S.p.A. | Via Romana 34/6 - 42028 Poviglio (RE) Italy | info@heila.com | www.heila.com



Custom Built Marine & Offshore Cranes

FULLY FOLDABLE CRANE

HLM 10-3S MODEL

TECHNICAL SPECIFICATION

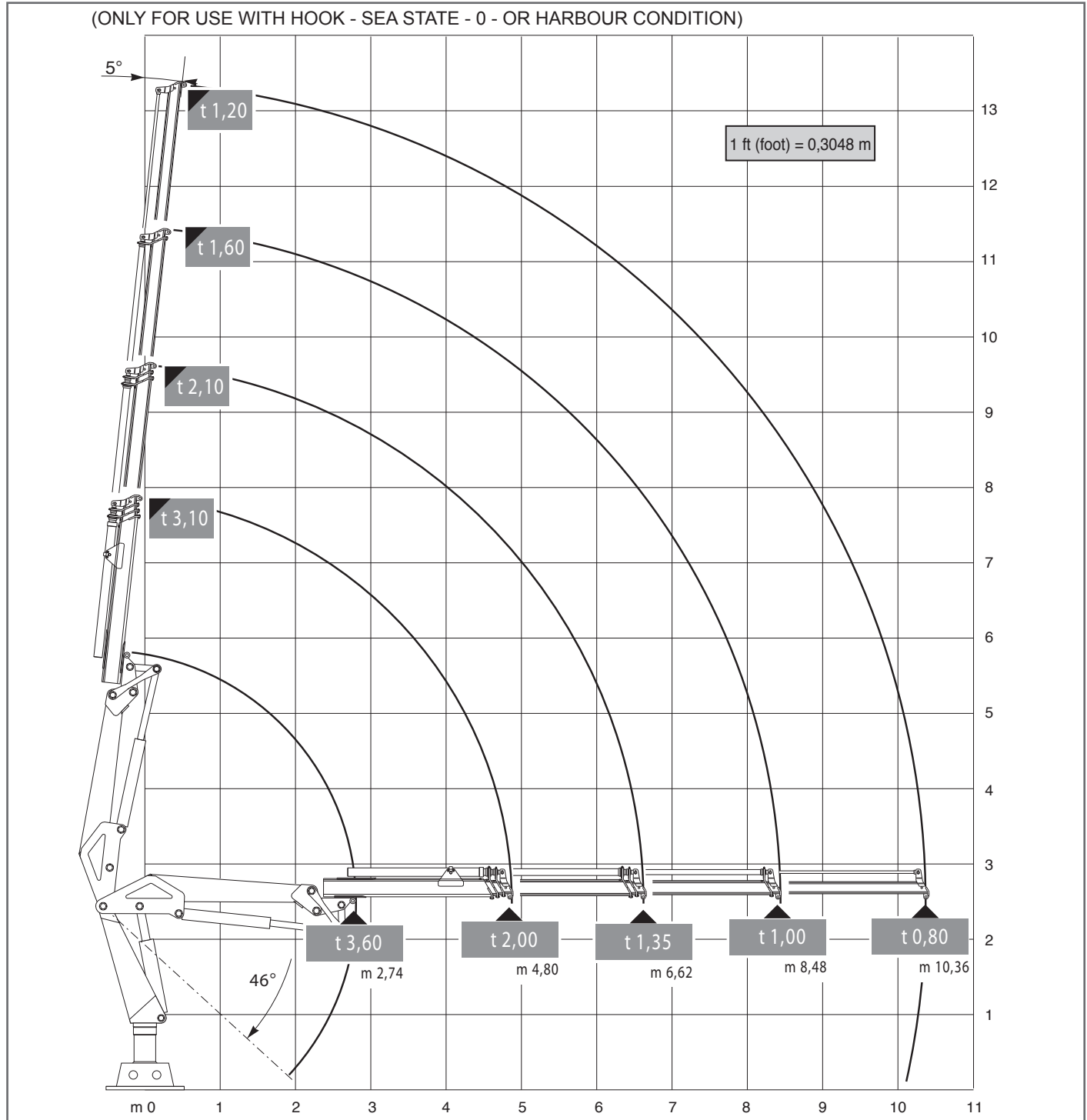

October 2014

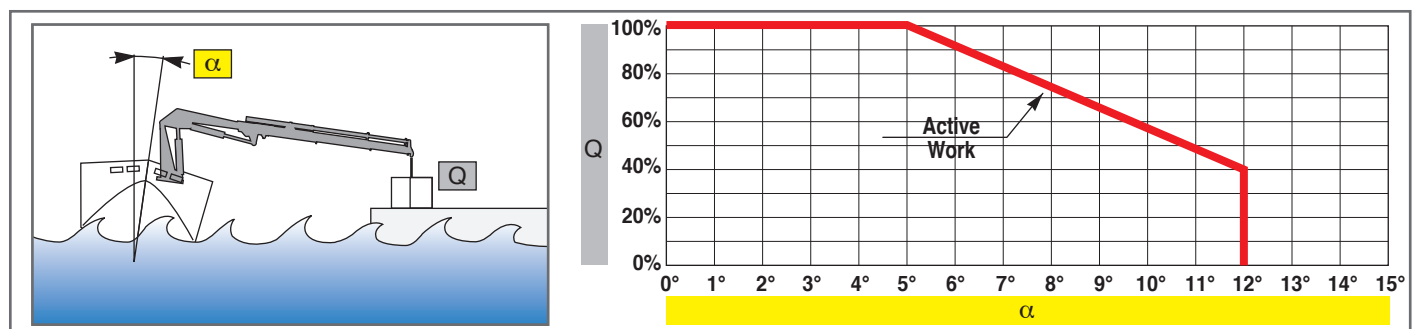

The technical data contained in this card are only indicative and can be changed without notice.

HLM10-3S Rev.00