



National N-100 Articulating Crane

From
America's
Truck-Mounted
Hydraulic
Crane Leader



- **Crane Rating:**
99,300 ft•lb
(13.73 t•m)
- **Maximum Capacity:**
7 tons (6.35 t)
- **Maximum
Vertical Reach:***
55 ft 3 in (16.8 m)
- **Horizontal Reach:**
45 ft 2 in (13.8 m)
- **Reach Below
Truck Frame:**
33 ft 11 in (10.3 m)
- **Total Hydraulic
Extension:**
38 ft 2 in (11.6 m)

* Maximum vertical reach is from ground level, mounted on a 42-in (1067-mm) high truck frame

**NATIONAL
CRANE
A Grove
Worldwide
Company**



National Articulating Cranes

The National Advantage

When you invest in a National articulating crane, you are assured of these competitive advantages:

Quality

National cranes are designed for durability, performance, and ease of service. National's cutting-edge technologies set the industry standard for the manufacture of lifting and materials handling equipment. An experienced workforce turns innovative designs into quality-crafted cranes. Factory prototypes are subjected to the toughest testing requirements in the industry. Each National crane is checked throughout the manufacturing and assembly process, then given a detailed final inspection before it is released from the factory.

Performance

Each user-friendly National gives you what you expect in a crane. Long reach. High capacity. Fast set-up. Easy operation. Smooth movement. Versatile accessories. Premium components. Add it all up—you'll find that a National is not only a pleasure to operate, but a reliable investment in bottom line performance.

Value

National has manufactured cranes since 1963. Nine out of ten are still on the job. With a National you get field-proven reliability plus the best factory/dealer support in the industry. National's warranty provides protection against defects in materials and workmanship for a full year from the date the customer takes delivery. Dealers maintain extensive parts stocking programs. Should a dealer be unable to supply a part you need, National's back-up program is committed to providing equipment replacement parts on a breakdown rush basis, holding your downtime to a minimum. These advantages enhance a National crane's resale value, consistently the highest in the industry.

National Crane is ISO 9001 certified





National N-100 Articulating Cranes

**99,300-ft•lb (13.72-t•m)
crane rating**

**7.0-ton (6.35-t)
maximum lifting capacity**

**55-ft 3-in (16.8-m)
maximum vertical reach***

**45-ft 2-in (13.8-m) horizontal
reach**

**33-ft 11-in (10.3-m) reach
below truck frame**

**38-ft 2-in (11.6-m) total
hydraulic extension**

**Maximum vertical reach is from ground level with the crane mounted on a 42-in (1067 mm) high truck frame*

Strong booms and jibs

- Four-stage proportional boom design extends each section in equivalent lengths during the telescoping process
- Proportional boom design enhances boom weight distribution, maximizes operational efficiency, and allows higher capacities, particularly in normal working radii
- Ultra-strong boom sections manufactured from low-alloy, high-strength steel
- Four-bar link design at outer boom pivot point facilitates close load placement to crane mast
- Long-wearing *Easy Glide* wear pads enhance smooth boom performance

Durable cylinders

- Cylinder shafts are hard chrome-plated and high pressure tubing is used wherever possible to reduce hose wear
- All cylinders are double acting for smooth, positive control

Clean design

- Wherever possible, heavy-duty wire-braided hoses are routed inside the mast and boom for protection from bumps, twists,

cuts and abrasions and to enhance the crane's appearance.

Swivel hook

- The boom nose or jib is equipped with a swivel hook and safety latch (rated for maximum crane capacity) designed to accept all boom tip options by a simple pin-on procedure

Counterbalance valves

- Pilot operated counterbalance valves on lift, fold and extend cylinders lock all cylinders in place in the event of hose failure or until they are powered to move—they prevent inadvertent cylinder movement

Capacity alert

- Standard capacity alert system helps prevent crane operation beyond crane capacity; blocks functions that increase overload

Efficient rotation

- Low maintenance shear ball bearing rotation system with smooth, precise planetary control
- When not powered, the swing is locked in place by a spring-applied, hydraulically released brake
- Powered by a high-torque, low-speed motor through a double reduction planetary gearbox

High performance hydraulics

- Couplings and fittings are of highest quality; hydraulic hoses, tubes and fittings have a 4:1 minimum safety factor on burst
- Inline hose swivels that rotate with the mast protect hoses from kinking and abrasion and help keep the end connections tight
- O-ring face seal fittings help eliminate leakage
- A high capacity, high pressure vane pump produces full system pressure—even at truck engine idle speed—and maintains high efficiency throughout its life
- A two-bolt mounting flange can be integrally mounted to most PTO's to simplify mounting
- Detachable oil tank (for easy maintenance) comes with an oil level sight gage, breather, mag-

netic plug and 10-micron (10 Hm) external return line filter integrally mounted to the crane frame; special design reduces mounting time and space requirements

Chrome-plated pins

- Large-diameter chrome-plated pins with encapsulated composite bearings provide long life with reduced maintenance

User-friendly operation

- Identical crane function controls on both sides of crane—same controls, same hand positioning
- Operator can work controls from either station, keeping boom and load in full view at all times
- Boom can be worked and rotated simultaneously
- Extra-fine metering and low spool forces for smooth, precise fingertip control
- Control knobs are illustrated with function symbols
- Additional valve banks for operating hydraulic accessories can easily be added

Solid Stability

- 16-ft (4.9-m) hydraulic outriggers provide solid stability—even in soft or uneven ground conditions (minimum trucks may require optional extra-wide 18-ft outriggers)
- 25.44-in (646-mm) hydraulic-powered outrigger legs set up quickly and easily from either side of the crane
- Standard outrigger pads are 8x14 in (203 x 352mm)
- Enclosed outrigger cylinders with pilot operated check valves lock automatically when stowed so they will not leak down in transit
- Legs are removable for shipment and storage

Simplified Mounting

- Easy three-point clamp-on mounting minimizes crane and truck-frame stress
- Mounts on standard, single-axle trucks

A wide choice of accessories (see page 8)



National N-100 Crane Specifications

Technical Data

| | | |
|----------------------------------------|-------------------------------------------|------------|
| Working pressure..... | 3,550 psi..... | 245 bar |
| Pump Capacity (vane-type pump)..... | 14 gal/min..... | 53 L/min |
| Reservoir oil capacity..... | 19.9 gal..... | 75 L |
| Outrigger span..... | 16 ft***..... | 4.88 m |
| Outrigger vertical travel..... | 25.44 in..... | 646 mm |
| Stowed height (above truck frame)..... | 7 ft 8 in..... | 2337 mm |
| Basic Model N-100/31 weight*..... | 5,550 lbs..... | 2517 kg |
| Filter..... | 10 micron replaceable (spin-on type)..... | 10 Hm |
| Rotation (non-continuous)..... | 395 degree..... | 395 degree |
| Mounting space required..... | 36.5 in..... | 927 mm |
| with optional winch..... | 47.5 in..... | 1155 mm |
| with optional reel..... | 45.0 in..... | 1143 mm |
| Boom rotation speed..... | 360° in 32 sec | |
| Boom hydraulic extension speed..... | 18 sec for Model H31** | |
| Boom hydraulic retraction speed..... | 12 sec for Model H31** | |

Note: Contact the factory for continuous duty cycle applications

**Crane options will increase crane weight*

***Approximate*

****Less than minimum chassis may require optional 18-ft outrigger*



Caution

- Do not operate crane booms, jib extensions, any accessories or loads within 10 ft (3 m) of live power lines or other conductors of electricity
- All capacities shown are maximum allowable loads, including the weight of any attached accessories
- Do not exceed capacities at reduced radii

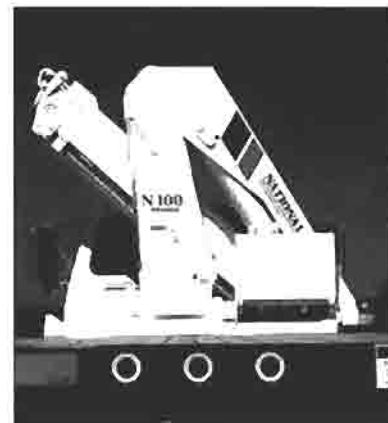



National N-100 Crane Specifications

The Basic N-100

- 99,300-ft•lb (13.72-t•m) crane rating
- 7.0-ton (6.35-t) maximum lifting capacity
- Two out-and-down hydraulic outriggers extending to 16 feet (4.9 m)
- 395-degree rotation
- Five spool control valves
- Counterbalance valves on lift, fold, and extend; automatic check valves on outriggers
- High-capacity four-bar linkage at outer boom fold joint
- Dual controls
- Manual cabled engine speed control
- Hydraulic capacity alert (HCA) system
- Hydraulic reservoir
- Hydraulic pump and easy mounting group
- Crane hook

Ranges are indicative of unloaded conditions. Capacity loaded conditions may restrict range because of deflection. Boom positions must be optimized to achieve shown capacities.

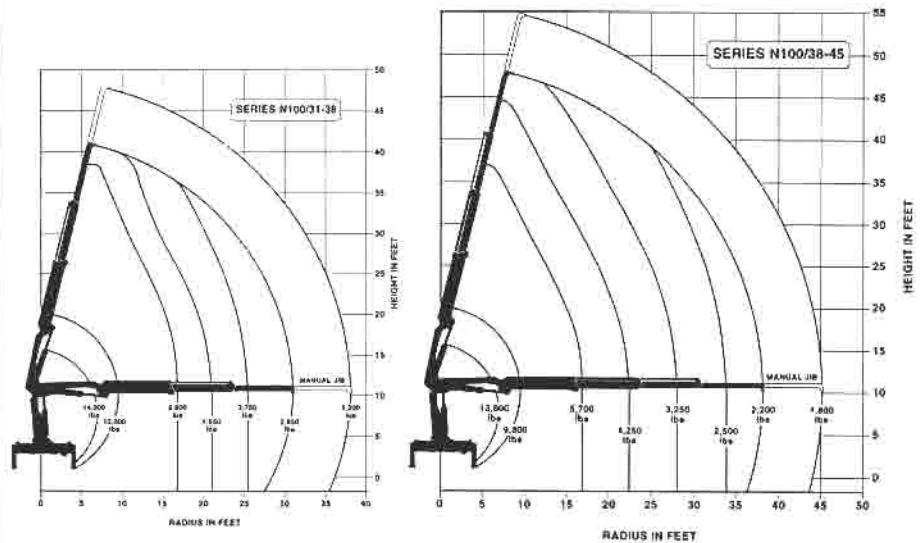

Model 31/38

- Mast, inner boom, outer boom, two hydraulic and one manual extension reaching to 38 ft 2 in (11.6 m)
- 44-ft 11-in (13.7-m) reach above truck frame
- 30-ft 2-in (9.2-m) reach below truck frame
- 48-ft 5-in (14.7-m) maximum vertical reach when mounted on a 42-in (1067-mm) high truck frame

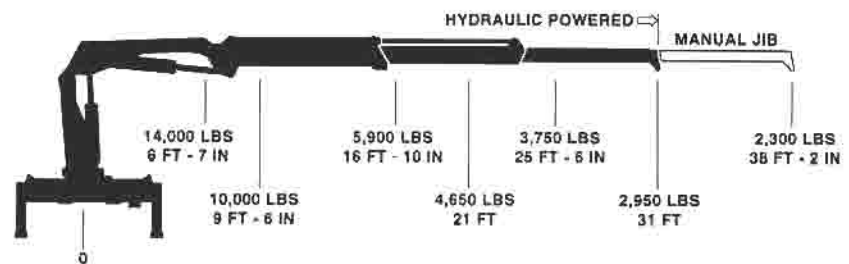

Model 38/45

- Mast, inner boom, outer boom, three hydraulic and one manual extension reaching to 45 ft 2 in (13.8 m)
- 52-ft (15.8-m) reach above truck frame
- 33-ft 11-in (10.3-m) reach below truck frame
- 55-ft 6-in (16.9-m) maximum vertical reach when mounted on a 42-in (1067 mm) high truck frame

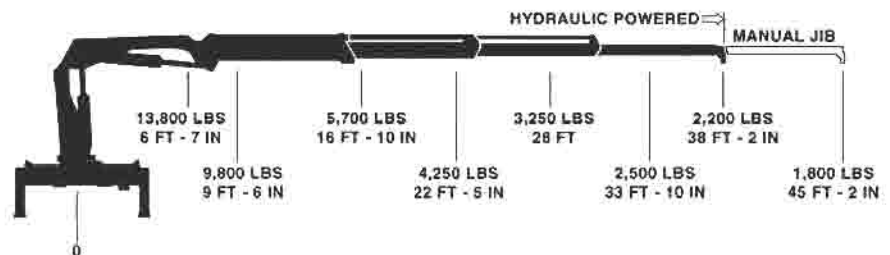



National N-100 Mounting Specifications

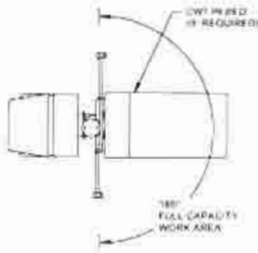
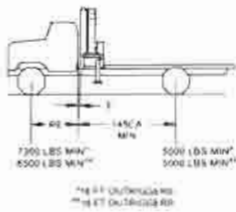

Behind Cab Mount/180-degree Stability

- Minimum wheelbase: 214 in (5436 mm)
- Cab to rear axle (CA): 145 in (3683 mm)
- Recommended front axle rating: 12,000 lbs (5443 kg) GAWRF
- Recommended rear axle rating: 21,000 lbs (9526 kg) GAWRR
- Recommended vehicle rating: 33,000 lbs (14 969 kg) GVWR
- Working area: 180 degrees
- Truck weight: 13,000 lbs (5897 kg) minimum
- Chassis weight front axle: 7,400 lbs (3357 kg) minimum
- Chassis weight rear axle: 5,600 lbs (2540 kg) minimum
- Frame 50,000 psi (345 MPa) steel: 21-in³ (344.2-cm³) section modulus
- Frame 110,000 psi (759 MPa) steel: 14-in³ (229.5-cm³) section modulus
- Frame height: 42 in (1067 mm) or less preferred
- Power take-off: 70 to 85 percent of engine speed; minimum 33-hp (24.6 kW) at 1,500 rpm

Note: 18-ft outrigger option may be required on less than minimum chassis

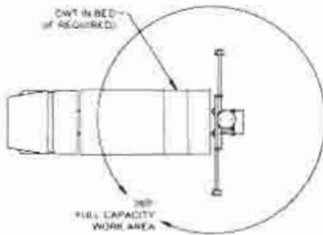
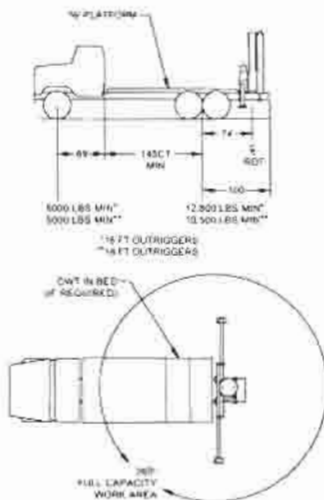

Rear Mount/360-degree Stability

- Minimum wheelbase: 214 in (5436 mm)
- Cab to rear axle (CA): 145 in (3683 mm)
- After frame (AF): 100 in (2540 mm) minimum
- Recommended front axle rating: 12,000 lbs (5443 kg) GAWRF
- Recommended rear axle rating: 34,000 lbs (15 422 kg) GAWRR
- Recommended vehicle rating: 46,000 lbs (20 412 kg) GVWR
- Working area: 360 degrees
- Truck weight: 16,400 lbs (7439 kg) minimum
- Chassis weight front axle: 6,100 lbs (2767 kg) minimum
- Chassis weight rear axle: 10,300 lbs (4672 kg) minimum
- Frame 110,000 psi (759 MPa) steel: 15.9-in³ (260.6-cm³) section modulus
- Frame height: 42 in (1067 mm) or less preferred
- Power take-off: 70 to 85 percent of engine speed; minimum 33-hp (24.6 kW) at 1,500 rpm

Note: 18-ft outrigger option may be required on less than minimum chassis

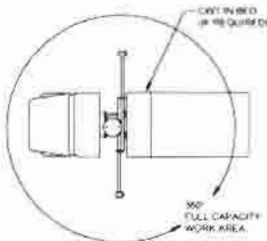
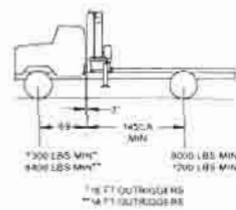

Behind Cab Mount/360-degree Stability

- Minimum wheelbase: 214 in (5436 mm)
- Cab to rear axle (CA): 145 in (3683 mm)
- Recommended front axle rating: 12,000 lbs (5443 kg) GAWRF
- Recommended rear axle rating: 21,000 lbs (9526 kg) GAWRR
- Recommended vehicle rating: 33,000 lbs (14 969 kg) GVWR
- Working area: 360 degrees
- Truck weight: 15,600 lbs (7076 kg) minimum
- Chassis weight front axle: 7,200 lbs (3266 kg) minimum
- Chassis weight rear axle: 8,400 lbs (3810 kg) minimum
- Frame 50,000 psi (345 MPa) steel: 21-in³ (344.2-cm³) section modulus
- Frame 110,000 psi (759 MPa) steel: 14-in³ (229.5-cm³) section modulus
- Frame height: 42 in (1067 mm) or less preferred
- Power take-off: 70 to 85 percent of engine speed; minimum 33-hp (24.6 kW) at 1,500 rpm

Note: 18-ft outrigger option may be required on less than minimum chassis



National N-100 Dimensional Specifications

Notes:

These notes pertain to mounting specification data on preceding page.

- *Truck used for mounting must meet these minimum requirements for capacity loads*
- *Always specify Gross Axle Weight Rating (GAWR) when purchasing trucks*
- *Rotate loads slowly and smoothly for maximum control*
- *Use caution when rotating boom from areas supported by outriggers to areas supported by springs—vehicle level changes as springs compress*
- *Under-minimum front or rear axle chassis weights may require counterweight to keep unit stable*
- *Diesel engines, longer wheelbase or service bodies may increase minimum axle requirements—contact factory for information*
- *Diesel engines require variable speed governor*
- *Chassis counterweight may include bed, PTO, pump, rear bumper, or any other permanently attached items (other than the crane itself)*

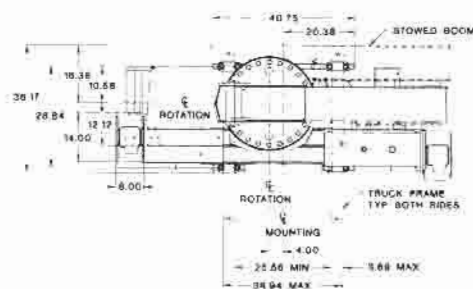
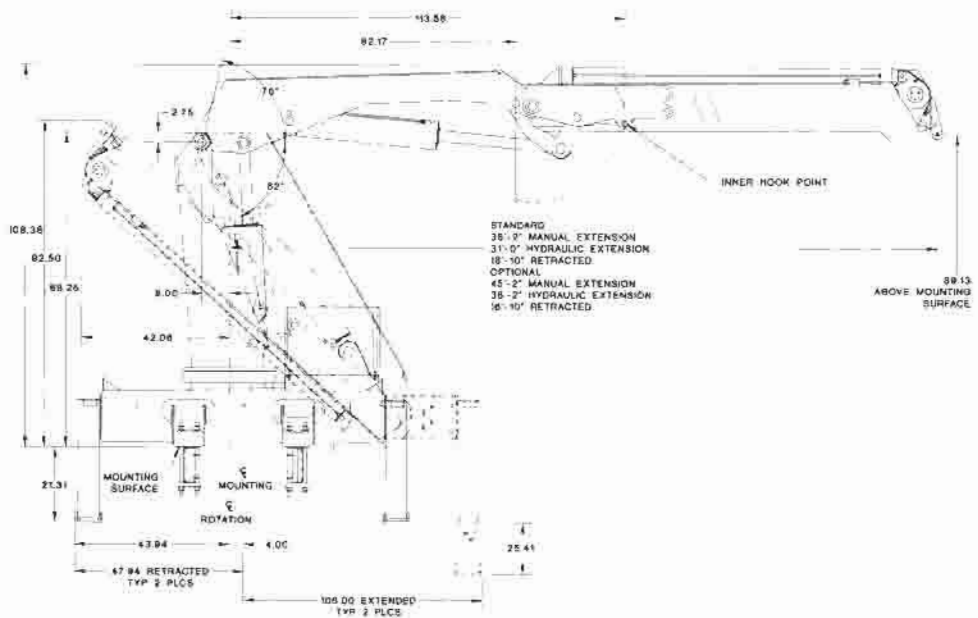

Rotation: 395 degree
(non-continuous)

Maximum Load Moment:
122,787 ft•lb (17.01 t•m)

Maximum Thrust Load:
17,390 lbs (7905 kg) at mounting
surface

Maximum Rotational Moment:
11,334 ft•lb (1.57 t•m)



National N-100 Accessories

Every National is part of a complete lifting system that lets you do more work faster, with less equipment and manpower. You can equip your crane to perform jobs that would otherwise call for a fleet of specialized equipment.

Information sheets on specific accessories are available. Contact National Crane or your National dealer to learn more about these cost-efficient accessories.



Note:

Weights of all accessories attached to the boom or loadline of the crane must be deducted from the effective lifting capacity. Additional accessories not listed may be available. Not all accessories are available for all crane series, and some accessories cannot be used in combination with other accessories. Consult your dealer or the factory for accessory capabilities, availability and pricing.

Remote Controls

A one-hand remote control, ideal for precise control and total load visibility. Diesel engines require electric shut-off.

- **Model MR4**
- **Model MR5** (requires AH1)
- **Model MR6** (requires AH2)

Radio Remote Controls

Eliminate handling and maintenance concerns that accompany cabled remotes. Operate to a range of approximately 400 ft (122 m), varying with conditions.

- **Model MR4R**
- **Model MR5R** (requires AH1)
- **Model MR6R** (requires AH2)

Winch

Heavy-duty, easy single pin attachment at boom-tip sheave head. Includes winch control and anti-two-block system.

- **Model N10**

Pallet Fork

Forks with 4,400-lb (1996 kg) capacity, plus adjustable throat and teeth.

- **Model MKF** (self leveling adjustable throat)
- **Model HKF** (hydraulic leveling adjustable throat, requires AH1 or RAH1)
- **Model HKFR** (hydraulic leveling adjustable throat, hydraulic rotator requires AH2 or RAH2)

Grapple

Grapples are available in butt- or bypass-type. Both come with a hydraulic rotator and quick connect fittings. Either type requires AH2.

- **Model BTG** (requires AH2)
- **Model BPG** (requires AH2)

Clam Bucket

The clam can be used to load or move materials in 1/3 yd³ (.25 m³) bites.

- **Model GPC** (requires AH2)

One-Person Basket

Gravity hung fiberglass with 300-lb (136-kg) capacity. Swing lock, body harness, and lanyard.

- **Model B1-LY** (with swing lock, body harness and lanyard)

Hydraulic Auger

Provides digging depths up to 4 ft 6 in (1.4 m) and flightings up to 18 in (457 mm). Requires AH1.

- **Model AG**
- **Model AGHP** (high-speed)

Accessory Control Valves

Allows operation of hydraulic accessories. Mounts easily on the control panel.

- **Model AH1** (one function for rotator or auger)
- **Model AH2** (two functions for grapple or clam)

National Crane reserves the right to change designs, prices and specifications at any time without notice.



NATIONAL CRANE
A Grove Worldwide Company

Your National Dealer:

General Offices

11200 North 148th Street
Waverly, NE 68462 USA
Phone: (402) 786-6300
FAX: (402) 786-6363
Web: <http://www.nationalcrane.com>