

F60A.21

F60A.21

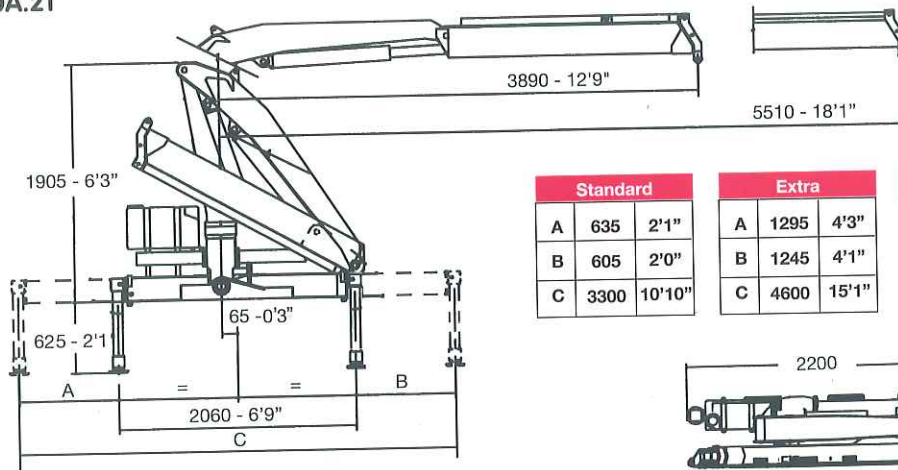

	Standard		Extra		Super Extra	
A	635	2'1"	1295	4'3"	1475	4'10"
B	605	2'0"	1245	4'1"	1410	4'8"
C	3300	10'10"	4600	15'1"	5000	16'5"

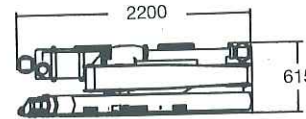

F60A.21

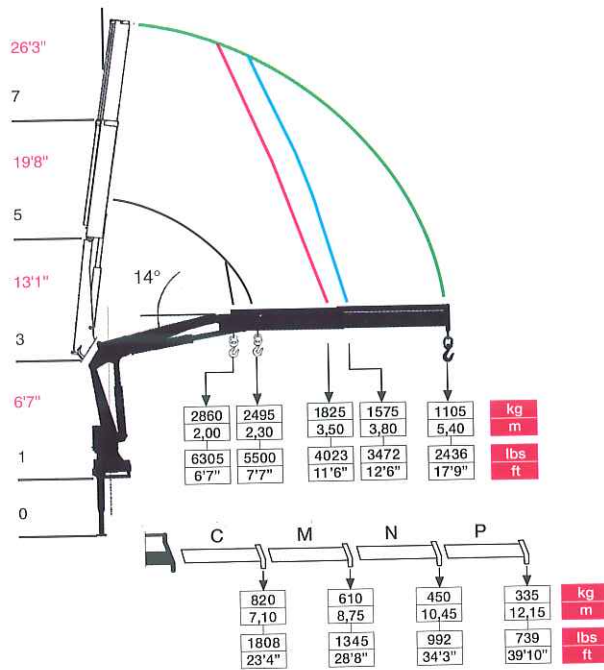

* HEAVY LIFT HOOK
PRIMER GANCHO
EERSTE HAAK

* BOOM TIP HOOK
GANCHO MOBIL
LASTHAAK - LASTVLUCHT

C N TELESCOPIC MANUAL EXTENSIONS
PROLONGAS MANUALES TELESCOPICAS
M P TELESCOPISCHE MECHANISCHE VERLEGING

F60A.21	
Lifting capacity Capacidad de elevación Hefvermogen	tm 6,4 lbs.ft 46250
Standard reach Brazo standard Standaardarm	m 5,50 ft 18'1"
Hydraulic extension Extensión hidraulica Hydraulische verlenging	m 1,60 ft 5'3"

F60A.21	
Rotation Ángulo de rotación Zwenkbereik	370°
Rotation torque Potencia de rotación Draaimoment	kNm 9,6 lbs.ft 7080
Working pressure Presión de trabajo Werkdruk	MPa 25,5 psi 3700

F60A.21	
Pump capacity Capacidad de la bomba Pomp-opbrengst	l/min 20 gal/min 5
Oil tank capacity Capacidad depósito aceite Capacitet van de olletank	l 60 gal 16
Cranes weight Peso de la grúa Eigen gewicht	kg 750 lbs 1600