

GENERAL DATA

CRANE CAPACITY	50 ton at 10 feet (45t at 3.0m)
BOOM	4-section, 37'6" – 111'6" (11.4 m – 34 m)
DIMENSION	
Overall Length	47'4" (14.43 m)
Overall Width (tracks extended)	18'4" (5.59 m)
Overall Width (tracks retracted)	12'0" (3.66 m)
Overall Height	10'0" (3.05 m)
MASS	
Gross Vehicle Mass (Standard Equipment Package)	103,640 LB (47,010 kg)
PERFORMANCE	
Travel Speed	0.78 mph – 1.29 mph (1.3 km/h – 2.1 km/h)
Gradability	57%

CRANE SPECIFICATION

MODEL

10010Mx

CAPACITY

50 ton at 10 feet (45t at 3.0m)

BOOM

4-section full power synchronized telescoping boom. Synchronized telescoping system consists of double acting hydraulic cylinders with load holding valves and extension and retraction cables.

- Retracted Length: 37'-6" (11.4 m)
- Extended Length: 111' 6" (34 m)
- Elevating Angles: -1° to 78°
- Boom Head: Seven, 19 inch (483 mm) diameter cast nylon sheaves on heavy-duty roller bearings (5 load bearing and 2 lead in sheaves)
- Extension Time: 102 s
- Elevating Time: 64 s

AUXILIARY BOOM HEAD

Quick reeve, single 19 inch (483 mm) diameter high-strength, cast nylon sheave mounted on a heavy-duty roller bearing.

- Hook Block: 50 ton (45 t) hook block – Five - 16 inch (406 mm) diameter sheaves mounted on heavy duty roller bearings with swivel hook and safety latch.
- Headache Ball: 12 ton (11) ball includes a swivel hook with a safety latch

COUNTERWEIGHT

20,000 LB (9,070 kg) single piece counterweight can be removed and installed via a pendant attached to the boom

WINCHES

Planetary geared single-speed winch includes a bent axis hydraulic motor, multi-disc internal brake, counterbalance valve, grooved drums and cable follower. Drum rotation indicator is included (complete winch performance specs on Page 4)

- Main Winch
 - Rope Diameter and Length: 5/8" x 600 ft (16 mm x 183 m)
 - Single line pull: 15,630 lb (69.5 kN)(first layer)
 - Single line speed: 247 ft/min (75 m/min)(4th layer)
- Auxiliary Winch
 - Rope Diameter and Length: 5/8" x 350 ft (16 mm x 107 m)
 - Single line pull: 15,630 lb (69.5 kN)(first layer)
 - Single line speed: 247 ft/min (75 m/min)(4th layer)

TRAVEL

Each side frame contains a pilot controlled, two-speed track drive with hydraulic axial piston motor and parking brake. Travel system provides skid steering and counter rotation.

- Low travel speed: 0.78 mph (1.3km/h)
- High travel speed : 1.29 mph (2.1 km/h)
- Gradeability (unladen): 68%

SWING

Gear motor driving a planetary gear reducer with a shaft mounted pinion, external gear shear ball slew bearing bolted to the superstructure and the carbody allows the superstructure to rotate 360°

- Swing Speed: 0 – 2.2 rpm
- Swing Parking Brake: Spring applied failsafe brake with hydraulic release that is controlled from the operators cab
- Swing Service Brake: Hydraulically applied, controlled through foot actuated pedal
- House Lock System: 2-position, manually pinned

LOAD MOMENT INDICATOR

Standard Rated Capacity Limiter and Anti-Two Block system

- Control function shutdown. Audible and visual warnings
- LCD screen provides a continuous display of working boom length, boom angle, working load radius, tip height, parts-of-line (operator set), machine track configuration, relative load moment, maximum permissible load and actual load.
- Anti-two block weight allows quick reeving of hook block

FRAME

The frame is an all-steel, welded structure, precision machined to accept attachment of the boom and swing components.

OPERATORS CAB

Fully-enclosed, air conditioned all-steel modular cab with lockable swinging door, acoustical lining, anti-slip floor and tinted safety glass.

- Rear view cameras are appropriately located as are three remote control work lights.
- Vent window in the rear of the cab.
- Grab bars and steps are located for easy access to the cab.
- Defroster, heater, circulating fan
- 2-speed windshield wiper, top glass wiper
- Six-way adjustable fabric seat with headrest, seat belt
- Dome light
- Dry-chemical fire extinguisher
- Two-way armrest mounted hydraulic joysticks control swing, , main winch, auxiliary winch. and boom hoist. Hydraulic foot pedals control the travel, boom extend, and swing service brake functions.
- Seat and armrest termination switches immediately disable all hydraulic functions as the operator rises from the seat or lifts the left hand armrest.

Dash instrumentation: tachometer, voltmeter, oil pressure gauge, temperature gauge, hour meter and fuel gauge. Indicators are provided for crane level, load moment, drum rotation, air filter restriction, hydraulic oil temperature and filter restriction, engine oil pressure and temperature.

ENGINE

- Make/ Model: Cummins QSB 6.7
- Type: 6 Cylinder, Water cooled, 4 Cycle
- Aspiration: Turbocharged and Aftercooled
- Max.Output: 260 hp (194 kw) @ 2200 RPM
- Max Torque: 728 Lb-ft (987 Nm) @ 1500 RPM
- Piston Disp: 6.7 liter
- Bore x Stroke:107mm x 124mm
- Emission Cert: U.S. EPA Tier 3, Euromot Stage IIIA
- Alternator: 130 amp

ELECTRICAL SYSTEM

12 VDC

FUEL SYSTEM

- Capacity: 80 gallon (378 liter)
- Filtration: Inline fuel/water separator and engine mounted fuel filter

SIDE FRAMES

Two welded steel side frames are paired with a track group. The side frames extend and retract hydraulically and are controlled from the cab.

- Track Rollers:Two top and thirteen bottom sealed rollers on each track frame Idler: Oil filled, self lubricating with spring type tensioner
- Track Shoes:36 inch (900 mm), 3-bar semi grouser

HYDRAULIC SYSTEM

- Hydraulic Pumps: Two high pressure, variable axial piston pumps with load sense and power limiting control for crane functions.
- Directional Valves: Multiple pressure and flow compensated valves with integrated relief valves controlled by hydraulic pilot signals.
- Pump output: 154 gpm (583 l/min) @ 2100 RPM engine speed. 4,800 psi (330 bar) maximum pressure
- Reservoir: 300 gallon (568 liter) capacity, spin-on filler/ breather, sight gauge, cleanout, and sump drain.
- Filtration: 5 micron, full flow tank mounted return filters with electrical clogging indicator. 5 micron pilot oil in-line pressure filter
- Diagnostic Ports: Provided for system, load sense, and pilot pressure

OPTIONAL EQUIPMENT

- Boom Extension: Lattice type, swing away
 - Length: 30 feet (9.1m)
 - Head: Two, 19-inch (483 mm) diameter cast nylon sheaves on heavy-duty roller bearings
 - Max. Lifting Height: 142 ft (43.3 m)
- Boom Jib: Lattice type, swing away, stores along boom extension
 - Length: 20 feet (6.1m)
 - Offset Angles: 15° & 30°
 - Max. Lifting Height: 162 ft (49.4 m)
- Track Shoes: 30 inch (762 mm) 3-bar semi grouser
- Track Shoes: 31.5 inch (800 mm) flat shoe
- Auger Ready Package: Includes hoses, fasteners and stowage bracket assembly mounted to the base section of the boom with a flow capability of 34 gpm (130 l/min)
- Complete Auger Package: Adds a two speed auger motor/gear box and one 60 inch (1.52 m) kelly bar to the Auger Ready Package.
- Tool Circuit: Provides 5 gpm (23 l/min) and 10 gpm (45 l/min) at 2,500 PSI (176 bar) through a 50 foot (15.2m) twin hose reel with quick disconnect fittings to operate open center tools.
- Free Fall Hoists: All winches are available in controlled free fall configurations.
- Cold Weather Packages: Cold weather options are available for operation to -40°C (Consult factory for application support)
- Work Platform: Model WP750 – 36 in x 72 in (0.9m x 1.8m) , all steel, welded, two person platform with maximum capacity of 750 lbs (340 kg).
- Pole Claw: Heavy-duty pole claw with hydraulic clamp and tilt.
- Access walkways
- Radio control package.
- Rotation resistant wire rope.

MAIN WINCH

Planetary geared two-speed winch includes a bent axis, variable displacement hydraulic motor, a multi-disc internal brake, grooved drum and cable follower.
Wire Rope: 600 ft (183 m) 5/8 in (16 mm) 6 x 37 EIPS, IWRC, RRL. Line pulls are not based on wire rope strength. Drum rotation indicator is standard.

Rope Layer	Maximum Line Pull		Full Load Line Speed		High Line Speed		Layer		Total	
	lb	kn	ft/min	m/min	ft/min	m/min	ft	m	ft	m
1	15,630	69.5	185	56	392	119	104	32	104	32
2	14,070	62.6	206	63	436	133	116	35	220	67
3	12,790	56.9	227	69	480	146	127	39	347	106
4	11,720	52.1	247	75	523	159	139	42	486	148
5	10,820	48.1	268	82	567	173	151	46	637	194
6	10,050	44.7	289	88	611	186	162	50	799	244

AUXILIARY WINCH

Planetary geared two-speed winch includes a bent axis, variable displacement hydraulic motor, a multi-disc internal brake, grooved drum and cable follower.
Wire Rope: 350 ft (107 m) 5/8 in (16 mm) 6 x 37 EIPS, IWRC, RRL. Line pulls are not based on wire rope strength. Drum rotation indicator is standard.

Rope Layer	Maximum Line Pull		Full Load Line Speed		High Line Speed		Layer		Total	
	lb	kn	ft/min	m/min	ft/min	m/min	ft	m	ft	m
1	15,630	69.5	185	56	392	119	104	32	104	32
2	14,070	62.6	206	63	436	133	116	35	220	67
3	12,790	56.9	227	69	480	146	127	39	347	106
4	11,720	52.1	247	75	523	159	139	42	486	148

MACHINE WEIGHTS

STANDARD CRANE WITH 4 SECTION 111 ft 6 in (33.99 m) BOOM, 1 PIECE COUNTERWEIGHT & 36 in (914 mm) TRACK SHOES	99,536 lb	45,150 kg
Crane Less Counterweights and Track Frames	55,936 lb	25,370 kg
Counterweight	20,000 lb	9,070 kg
Track Frames, 2 pieces 11,800 lb (5,350 kg) each	23,600 lb	10,700 kg
OPTIONAL EQUIPMENT		
30 ft (9.14 m) Lattice Extension	1,700 lb	771 kg
20 ft (6.10 m) Jib (connects to head of Lattice Extension ONLY)	700 lb	318 kg
Auxiliary Nose Sheave	210 lb	95 kg
12 ton (11 mt) Headache Ball	404 lb	183 kg
50 ton (45 mt) Hook Block	1,300 lb	590 kg
Auxiliary Winch with Standard Rope	685 lb	311 kg
Auger Ready Package	440 lb	200 kg
Complete Auger Package	1520 lb	690 kg
60 in (1.52 m) Auger Kelly Bar	120 lb	54 kg
72 in (1.83 m) Auger Kelly Bar	140 lb	64 kg

* Deduction from Standard Crane Weight

DIMENSIONS

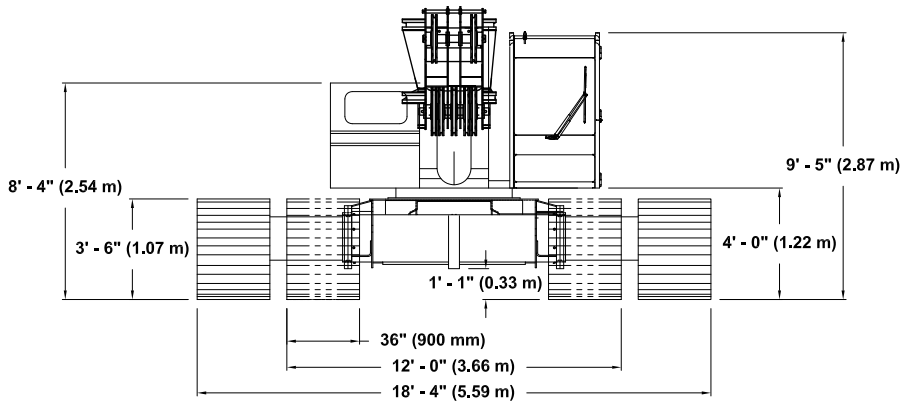
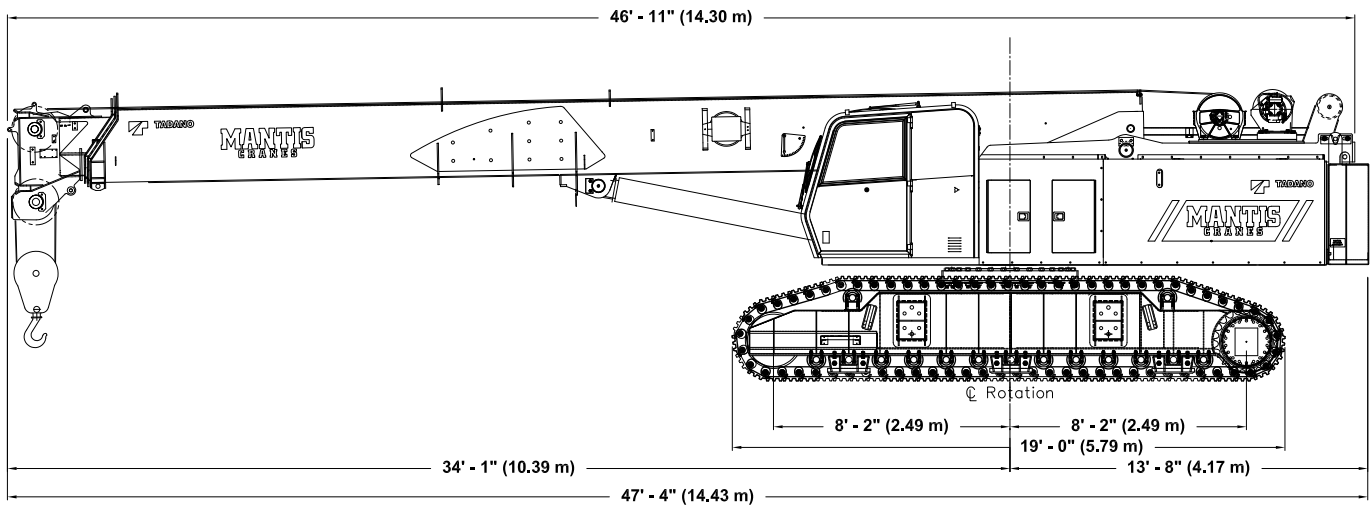

WIDTHS, WEIGHTS, AND GROUND PRESSURES*

Shoe Width	Overall Width		Area	Ground Pressure	Working Weight
	Retracted	Extended			
24 in (609 mm)	11 ft 0 in (3.35 m)	17 ft 2 in (5.23 m)	9,360 in ² (6.04 m ²)	10.7 psi (0.75 kg/cm ²)	99,690 lb (45,220 kg)
30 in (762 mm)	11 ft 6 in (3.51 m)	17 ft 8 in (5.39 m)	11,700 in ² (7.55 m ²)	8.7 psi (0.61 kg/cm ²)	101,670 lb (46,120 kg)
36 in (900 mm)	12 ft 0 in (3.66 m)	18 ft 4 in (5.59 m)	14,040 in ² (9.06 m ²)	7.4 psi (0.52 kg/cm ²)	103,640 lb (47,010 kg)

* Crane equipped with: 111 ft., 6 in. boom, extension, jib, 50 ton hook block, 12 ton headache ball

111 FT 6 IN MAIN BOOM, 30 FT EXTENSION & 20 FT JIB

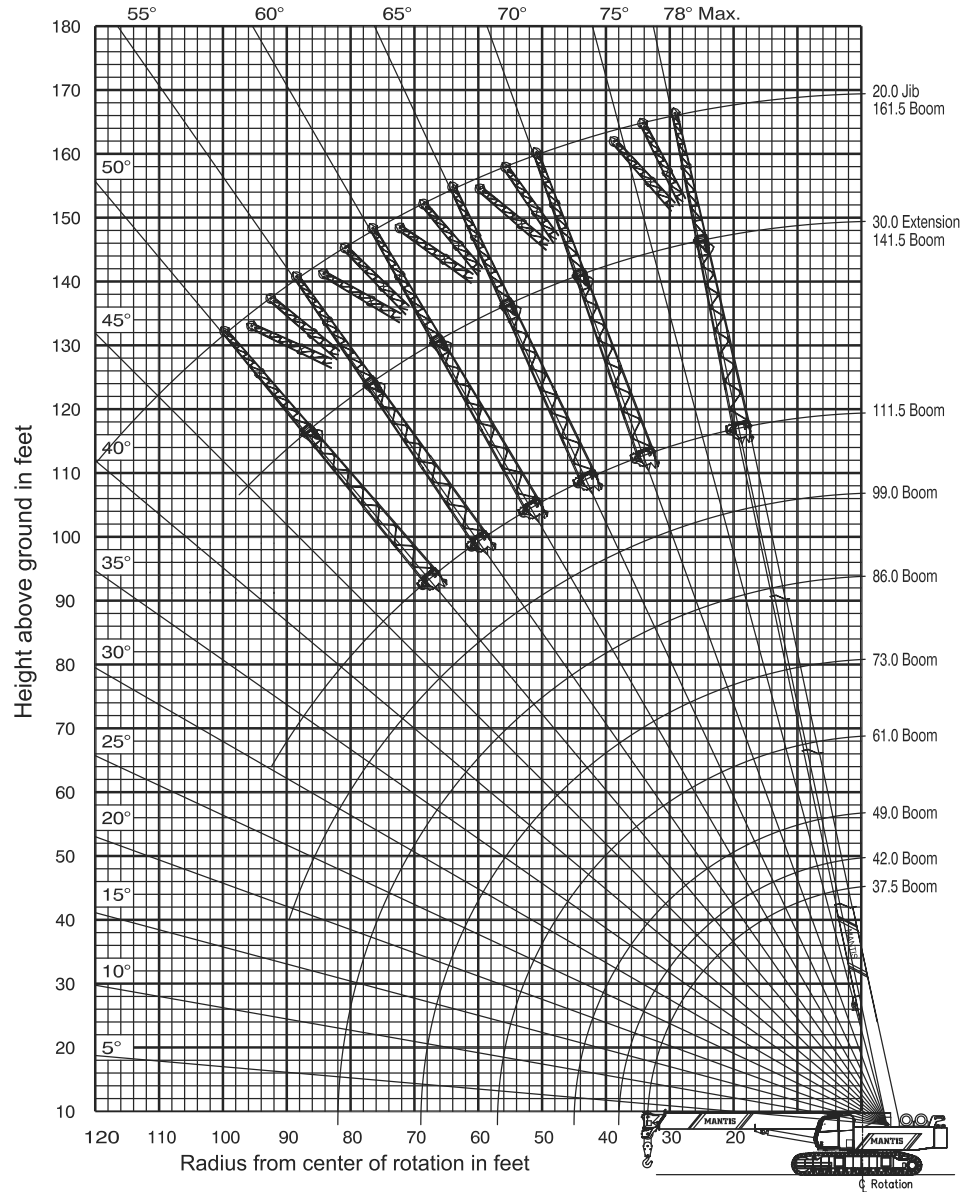
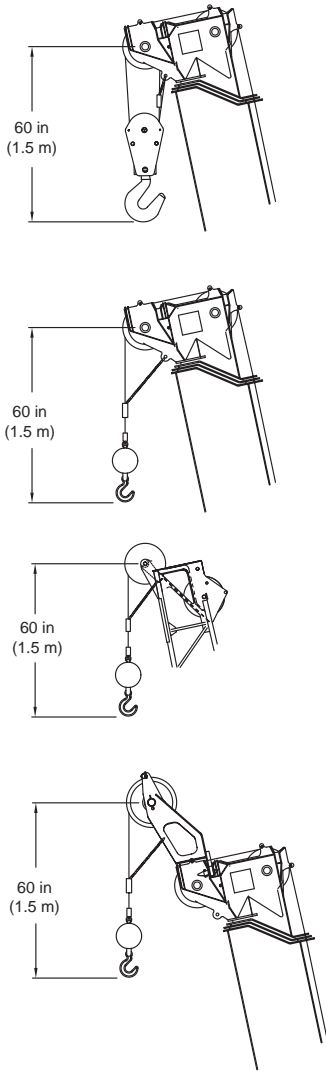

CAUTION: THESE CHART VALUES ARE ONLY A GUIDE AND MUST NOT BE USED TO OPERATE THE CRANE.
USE ONLY THE IN CAB LOAD CHARTS AND OPERATORS MANUAL FURNISHED WITH THE CRANE.

LOAD CHARTS

360 DEGREE RATING - LOADS IN lb x 1000

MAIN BOOM with TRACKS FULLY EXTENDED										
20,000 lb COUNTERWEIGHT										
RADIUS (ft)	MAIN BOOM LENGTH (ft)								RADIUS (ft)	
	37.5	42.0	49.0	61.0	73.0	86.0	99.0	111.5		
10	100.0	90.0	86.0	79.0*						10
	70.1°	72.3°	74.9°	78.0°						
12	82.5	80.0	76.0	72.0*						12
	66.8°	69.4°	72.5°	76.0°						
15	66.0	64.0	61.0	59.5	48.0	44.0*				15
	61.6°	64.9°	68.7°	73.1°	75.9°	78.1°				
20	53.2	51.1	49.1	51.4	43.0	40.0	38.0*			20
	52.2°	57.0°	62.2°	68.1°	71.8°	74.7°	76.7°			
25	39.6	38.7	37.3	38.0	38.6	39.0	36.0	35.0*		25
	41.4°	48.2°	55.3°	62.9°	67.6°	71.2°	73.7°	75.6°		
30	29.5	29.0	28.7	28.5	29.2	29.9	30.2	30.5		30
	27.0°	37.8°	47.6°	57.4°	63.3°	67.6°	70.7°	72.9°		
35		22.3	22.0	21.8	22.5	23.3	23.7	24.1		35
		23.7°	38.8°	51.5°	58.7°	63.9°	67.6°	70.2°		
40			16.8	16.6	17.3	17.9	18.6	19.1		40
			27.7°	45.1°	54.0°	60.1°	64.4°	67.4°		
45			12.8	13.2	13.7	14.3	15.0	15.5		45
			3.1°	37.8°	48.9°	56.1°	61.1°	64.6°		
50				10.5	11.1	11.7	12.4	13.0		50
				29.0°	43.3°	52.0°	57.7°	61.7°		
55				8.4	8.9	9.7	10.4	10.8		55
				16.0°	37.1°	47.6°	54.2°	58.7°		
60					8.0	8.4	8.7	9.0		60
					29.8°	42.8°	50.5°	55.7°		
65					6.7	7.0	7.3	7.6		65
					20.1°	37.5°	46.6°	52.4°		
70						5.7	6.0	6.3		70
						31.5°	42.4°	49.1°		
75						4.6	5.0	5.3		75
						24.2°	37.8°	45.6°		
80						3.7	4.1	4.4		80
						13.3°	32.7°	41.8°		
85							3.2	3.6		85
							26.7°	37.7°		
90							2.7	3.0		90
							19.1°	33.2°		
95							2.1	2.4		95
							1.5°	28.1°		
100								1.9		100
								21.8°		
105								1.1		105
								12.9°		

* Capacity based on maximum obtainable boom angle.
 ° Boom angles are stated in degrees.

NOTE: Capacities appearing above the bold line are based on structural strength; tipping should not be relied upon as a capacity limitation.
 Capacities appearing below the bold line are based on stability and do not exceed 75% of tipping.

CAUTION: THESE CHART VALUES ARE ONLY A GUIDE AND MUST NOT BE USED TO OPERATE THE CRANE.
 USE ONLY THE IN CAB LOAD CHARTS AND OPERATORS MANUAL FURNISHED WITH THE CRANE.

LOAD CHARTS

360 DEGREE RATING - LOADS IN lb x 1000

MAIN BOOM with TRACKS FULLY RETRACTED		
20,000 lb COUNTERWEIGHT		
RADIUS (ft)	MAIN BOOM LENGTH (ft) 37.5 to 111.5	RADIUS (ft)
15	42.6	15
17	34.3	17
19	28.2	19
21	23.7	21
23	20.2	23
25	17.4	25
27	15.1	27
29	13.1	29
30	12.3	30
32	10.8	32
34	9.5	34
36	8.3	36
38	7.4	38
40	6.4	40
42	5.7	42
44	4.9	44
46	4.3	46
48	3.7	48
50	3.2	50
52	2.7	52
54	2.3	54
56	1.8	56
58	1.5	58
60	1.2	60

30' EXTENSION & 20' JIB						
with TRACKS FULLY EXTENDED						
20,000 lb COUNTERWEIGHT						
30' EXTENSION			20' JIB			
Boom Angle	Total Boom Length (ft)		Jib Offset Angles			Boom Angle
	67.5 to 110.0	> 110.0	0°	15°	30°	
78°	18.0	18.0	6.6	4.0	2.2	78°
75°	13.6	13.6	6.5	4.0	2.1	75°
72°	11.5	11.5	5.6	3.5	2.0	72°
70°	10.1	10.1	5.1	3.2	1.9	70°
68°	8.9	8.9	4.6	3.0	1.8	68°
65°	8.0	7.8	4.2	2.8	1.8	65°
62°	7.2	6.0	3.9	2.6	1.7	62°
60°	6.7	4.8	3.5	2.4	1.7	60°
58°	6.1	3.9	3.2	1.9	1.4	58°
55°	5.8	3.0	2.6	1.3	1.0	55°
52°	5.3	2.4	2.0	0.6	0.4	52°
50°	5.1	2.1	1.3	0.3	0.2	50°
48°	4.9	1.7				48°
45°	4.6	1.3				45°

° Boom angles are stated in degrees.

WEIGHT REDUCTIONS	
LOAD HANDLING DEVICES	
HOOKBLOCK: 50 Ton - 5 Sheave	1,300 lbs
OVERHAUL BALL: 12 Ton w/Swivel	396 lbs
OPTIONAL HANDLING DEVICES	
30 ft. Extension - Stowed**	350 lbs
30 ft. Extension - Erected**	2,000 lbs
30 ft. Ext. and 20 ft. Jib - Stowed**	750 lbs
30 ft. Ext. and 20 ft. Jib - Erected**	3,500 lbs
Auxillary Nose Sheave**	250 lbs

** Reduction of main boom capacities.

ZERO DEGREE BOOM ANGLE			
MAXIMUM CAPACITY			
with TRACKS FULLY EXTENDED			
20,000 lb COUNTERWEIGHT			
BOOM LENGTH (ft)	RADIUS (ft)	LOAD (lbs) (x 1000)	BOOM LENGTH (ft)
37.5	33.6	20.8	37.6
42	38.0	17.1	42
49	45.0	12.8	49
61	57.0	7.8	61
73	69.0	5.6	73
86	82.0	3.3	86
99	95.0	2.2	99
111.5	107.5	1.0	111.6

NOTE: Capacities appearing above the bold line are based on structural strength; tipping should not be relied upon as a capacity limitation. Capacities appearing below the bold line are based on stability and do not exceed 75% of tipping.

CAUTION: THESE CHART VALUES ARE ONLY A GUIDE AND MUST NOT BE USED TO OPERATE THE CRANE. USE ONLY THE IN CAB LOAD CHARTS AND OPERATORS MANUAL FURNISHED WITH THE CRANE.

LOAD CHARTS

360 DEGREE RATING - LOADS IN lb x 1000

AUXILIARY BOOM NOSE SHEAVE with TRACKS FULLY EXTENDED									
20,000 lb COUNTERWEIGHT									
RADIUS (ft)	MAIN BOOM LENGTH (ft)								RADIUS (ft)
	37.5	42.0	49.0	61.0	73.0	86.0	99.0	111.5	
10	11.0	11.0	11.0	11.0					10
	70.1 °	72.3 °	74.9 °	78.0 °					
12	11.0	11.0	11.0	11.0					12
	66.8 °	69.4 °	72.5 °	76.0 °					
15	11.0	11.0	11.0	11.0	11.0	11.0			15
	61.6 °	64.9 °	68.7 °	73.1 °	75.9 °	78.1 °			
20	11.0	11.0	11.0	11.0	11.0	11.0	11.0	11.0	20
	52.2 °	57.0 °	62.2 °	68.1 °	71.8 °	74.7 °	76.7 °	°	
25	11.0	11.0	11.0	11.0	11.0	11.0	11.0	11.0	25
	41.4 °	48.2 °	55.3 °	62.9 °	67.6 °	71.2 °	73.7 °	75.6 °	
30	11.0	11.0	11.0	11.0	11.0	11.0	11.0	11.0	30
	27.0 °	37.8 °	47.6 °	57.4 °	63.3 °	67.6 °	70.7 °	72.9 °	
35		11.0	11.0	11.0	11.0	11.0	11.0	11.0	35
		23.7 °	38.8 °	51.5 °	58.7 °	63.9 °	67.6 °	70.2 °	
40			11.0	11.0	11.0	11.0	11.0	11.0	40
			27.7 °	45.1 °	54.0 °	60.1 °	64.4 °	67.4 °	
45			11.0	11.0	11.0	11.0	11.0	11.0	45
			3.1 °	37.8 °	48.9 °	56.1 °	61.1 °	64.6 °	
50				10.5	11.0	11.0	11.0	11.0	50
				29.0 °	43.3 °	52.0 °	57.7 °	61.7 °	
55				8.4	8.9	9.7	10.4	10.8	55
				16.0 °	37.1 °	47.6 °	54.2 °	58.7 °	
60					8.0	8.4	8.7	9.0	60
					29.8 °	42.8 °	50.5 °	55.7 °	
65					6.7	7.0	7.3	7.6	65
					20.1 °	37.5 °	46.6 °	52.4 °	
70						5.7	6.0	6.3	70
						31.5 °	42.4 °	49.1 °	
75						4.6	5.0	5.3	75
						24.2 °	37.8 °	45.6 °	
80						3.7	4.1	4.4	80
						13.3 °	32.7 °	41.8 °	
85							3.2	3.6	85
							26.7 °	37.7 °	
90							2.7	3.0	90
							19.1 °	33.2 °	
95							2.1	2.4	95
							1.5 °	28.1 °	
100								1.9	100
								21.8 °	
105								1.1	105
								12.9 °	

° Boom angles are stated in degrees.

NOTE: Capacities appearing above the bold line are based on structural strength; tipping should not be relied upon as a capacity limitation.
Capacities appearing below the bold line are based on stability and do not exceed 75% of tipping.

CAUTION: THESE CHART VALUES ARE ONLY A GUIDE AND MUST NOT BE USED TO OPERATE THE CRANE.
USE ONLY THE IN CAB LOAD CHARTS AND OPERATORS MANUAL FURNISHED WITH THE CRANE.

LOAD CHARTS

WP-750 WORK PLATFORM Installed on MANTIS MODEL 10010Mx as originally manufactured and equipped by Tadano Mantis Corporation

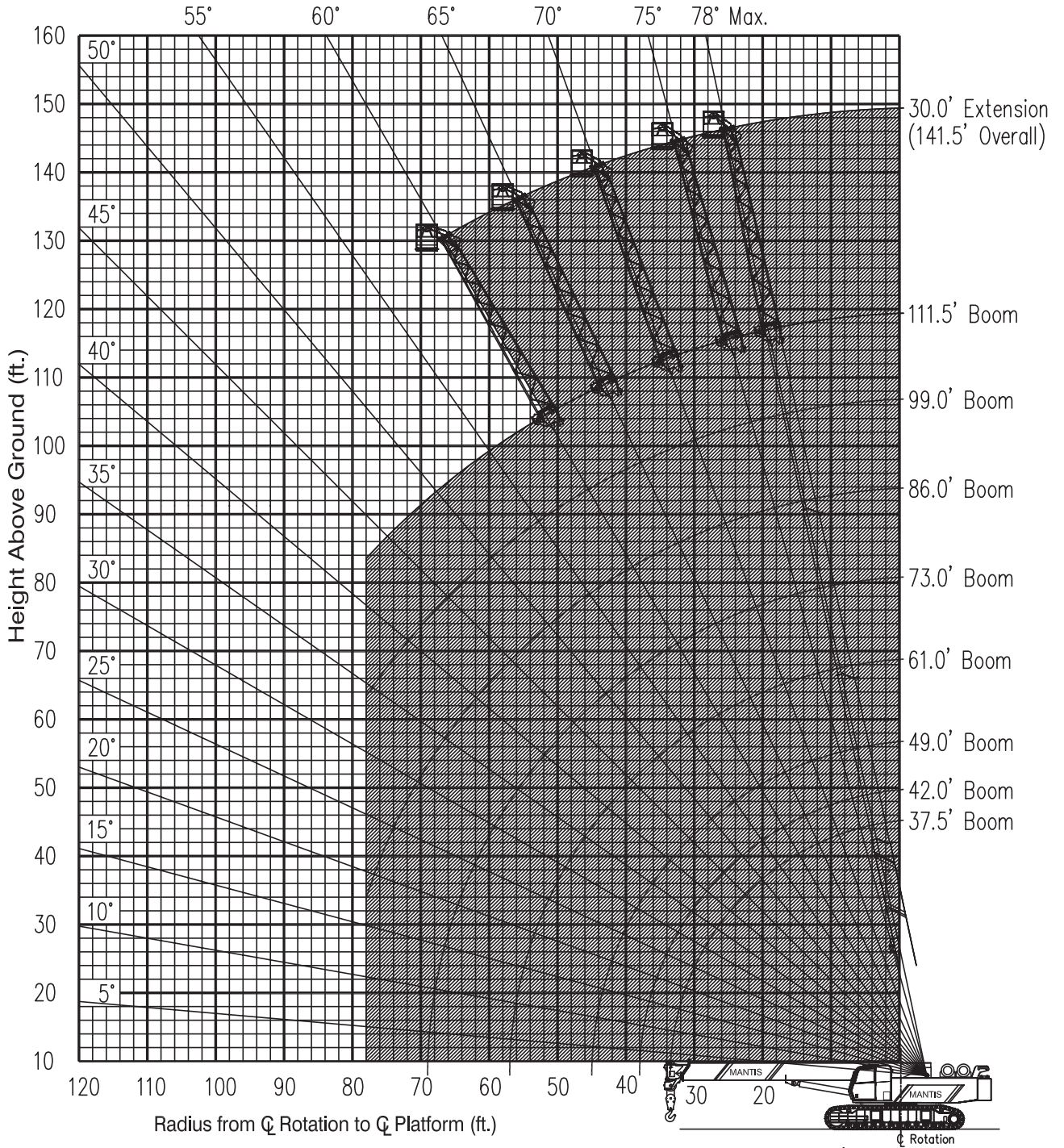

Limits of operation: Maximum load capacity = 750 lb Maximum radius when mounted on main boom = 78 ft

CAUTION: THESE CHART VALUES ARE ONLY A GUIDE AND MUST NOT BE USED TO OPERATE THE CRANE.
USE ONLY THE IN CAB LOAD CHARTS AND OPERATORS MANUAL FURNISHED WITH THE CRANE.

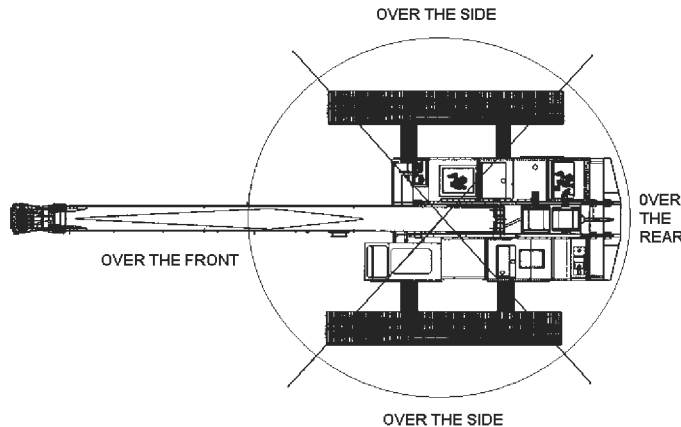

MANTIS MODEL 10010Mx				
WIRE ROPE LINE PULL CAPACITIES				
PARTS OF LINE	MAIN WINCH (pounds)	AUX WINCH (pounds)	PARTS OF LINE	MAIN WINCH (pounds)
1	11,771	11,771	6	70,626
2	23,542	23,542	7	82,397
3	35,313	N/A	8	94,168
4	47,084	N/A	9	105,939
5	58,855	N/A	10	117,710

5/8 inch diameter wire rope, 6 x 37 Class, EIP, IWRC

PLEASE READ, UNDERSTAND, AND FOLLOW THE MANUALS FURNISHED WITH THE CRANE (OPERATORS AND SAFETY) AS WELL AS THE CAPACITY LIMITATIONS AND GENERAL CONDITIONS LISTED BELOW PRIOR TO OPERATION OF THE CRANE. FAILURE TO DO SO MAY RESULT IN AN ACCIDENT.

This MANTIS CRANE as manufactured by Tadano Mantis Corporation meets the requirements of ASME B30.5. Structure and stability have been tested in accordance with SAE J1063 and SAE J765, respectively. Lifting capacities as determined by boom length, angle or radius, apply only to machines as originally equipped by manufacturer and in a properly maintained condition. Capacities given are maximum covered by the manufacturer's warranty and are based on a freely suspended load with NO allowance for factors as out-of-level operation, supporting surface conditions, hazardous surroundings, experience of personnel, etc. The operator shall establish practical working loads based on prevailing operating conditions, such as, but not limited to the above.

When making lifts where capacities may be within a zone limited by structural strength, the operator shall determine that the weight of the load is known within plus or minus (+/-) ten percent (10%) before making lift. **DO NOT** lift load or extend boom without counterweight in place. Deductions from rated capacities must be made for the weight of the hook block, hook/ball, slings, spreader bar, or other suspended equipment.

Side pull on boom is extremely dangerous and must be avoided.

DO NOT exceed manufacturer's maximum specified reeving.

DO NOT use this chart if wind speed exceeds 20 mph. Consult the manufacturer for specialized load ratings.

Load radius is defined as the horizontal distance from the axis of rotation (with no load) to the center of the lifting device after load is applied. Boom angle is the included angle between the longitudinal axis of the boom base section and the Horizontal axis, after lifting load. The boom angle before lifting should be slightly greater than desired to account for boom deflection.

Boom angle/boom length relationships given are an approximation of the resulted load radius, which should be an accurate measurement. Boom height dimensions are measured from ground to center of lower boom head sheave.

It is permissible to attempt to telescope boom with a load within the limits of rated capacities. However, boom angle system hydraulic pressure, and/or boom lubrication may affect operation.

It is permissible to travel with loads within the rated capacity of the crane. Travel speeds should be greatly reduced to reflect terrain limitations and minimize dynamic loads applied to the crane structure.

CAUTION: THESE CHART VALUES ARE ONLY A GUIDE AND MUST NOT BE USED TO OPERATE THE CRANE.
USE ONLY THE IN CAB LOAD CHARTS AND OPERATORS MANUAL FURNISHED WITH THE CRANE.

10010Mx

50 Ton Telescopic Boom Crawler Crane

SPECIFICATION SHEET NO. 479-03/11

NOTES:

TADANO MANTIS CORPORATION

1705 Columbia Avenue • Franklin, TN 37064 USA • Toll-Free: 1-800-272-3325 • Fax: 615-790-6803 • mantiscranes.com