

NATIONAL CRANE

Series 1300

Hydraulic Crane 30 Ton

Load Ratings

⚠ DANGER

AN **UNTRAINED OPERATOR**
SUBJECTS HIMSELF AND
OTHERS TO
DEATH OR **SERIOUS** INJURY
YOU MUST NOT OPERATE
THIS CRANE UNLESS

- You have been trained in the safe operation of this crane.
- You read, understand and follow the ~~safety~~ and operating recommendations contained in the crane manufacturer's manuals, your employers work rules and applicable government regulations.
- You are sure that all safety signs, guards and other safety features are in place and in proper condition.

 **DANGER****GENERAL**

1. This equipment can be hazardous if improperly maintained or operated. Read and comply with the Operator's Manual supplied with this machine for information on safety, operation and maintenance before operating this machine. If these manuals are missing, order replacements from National Crane through the distributor.
2. Rated loads shown on the capacity chart pertain to this machine as originally manufactured and equipped. Modifications to the machine or use of equipment that is not factory specified or approved can be hazardous. Refer to capacity deduction chart for weights which must be deducted from rated loads when accessories are attached to boom or loadline.

SET-UP

1. Inspect vehicle and crane including crane operation prior to use each day.
2. Load ratings shown on the appropriate charts are maximum allowable loads with the crane mounted on a factory approved truck and all outriggers at either full span or at mid span range and set on a firm level surface so the crane is level and the tires are suspended. This machine is not rated for use without outriggers. All outriggers must be extended equally - Mid span must be pinned. This machine is not rated for use with outriggers retracted.
3. Depending on the nature of the supporting surface, structural supports under the outrigger floats may be necessary to spread the load to a larger bearing surface.
4. Always level the crane with the level indicator located at the outrigger control station.

OPERATION

1. Operation of this equipment in excess of maximum load rating and disregard of instructions is hazardous. Always refer to the capacity chart for load and area limits before operating the crane. Rated loads at rated radius shall not be exceeded. Overloading this crane may cause structural collapse or instability.
2. Use the LMI/angle indicator as a reference only. When lifting maximum loads, measure radius and be certain of load weight.
3. Full extended outrigger rated loads do not exceed 85% of the tipping load as determined by SAE Crane Stability Test Code J765a when mounted on a factory recommended truck. Mid span outrigger stability loads are determined per ISO 4305, 1991. Structurally limited ratings on the capacity chart are shaded. Stability limited loads are not shaded. Machine will not always tip before structural damage occurs.

4. Rated loads include the weight of the hook block, slings, and other lifting devices. Their weights must be subtracted from the listed rated load to determine the net load that can be lifted.

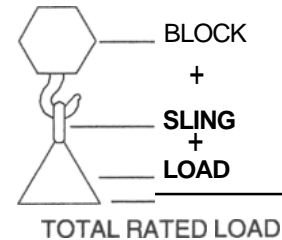

5. Rated loads must be reduced when lifting at the boom tip with a jib stowed. Refer to the chart labeled "Rated Load Reductions with Jib" for the reduction at each boom length.

6. Rated loads are based on freely suspended loads. Always position the boom tip directly over the load before lifting. No attempt shall be made to push down with the boom or move the load sideways in any direction by pulling or dragging the load.

7. The user shall operate at reduced ratings to allow for adverse job conditions such as soft or uneven ground, high winds or erratic operation which produce swinging (side) loads, experience of personnel, two machine lifts, or other hazardous conditions for safe operation.

8. Rated loads account for wind to 20 MPH on the boom capacities and to 15 MPH on jib capacities. Above these wind velocities, loads and/or boom lengths must be appropriately reduced for safe operation.

9. Do not operate at any radii beyond stability limit line on range chart. At these positions, the machine can overturn without any load on the hook.

10. When boom length or radius or both are between points listed on capacity chart, the smallest load shown at either the next larger radius or boom length shall be used.

11. Do not exceed jib capacities at any reduced boom length.

12. It is safe to telescope or retract any load listed if rating is not exceeded. Boom must be fully retracted against boom stops at all times when lifting minimum boom length capacity loads.

13. Always pay out loadline before extending boom to avoid damaging loadline or crane structure.

14. Loads lifted must be within safe winch capacity as well as safe crane capacity. Multiple part rope reeving must be used on loads exceeding winch single part rated pull. Jibs are rated for single part use only.

15. Do not operate the boom over personnel or allow them to walk or stand beneath the boom or load.

16. Do not allow personnel on carrier deck, or crane frame area when rotating crane.

17. Do not allow personnel to ride on hook, hook block, load or any device attached to the loadline. Handling of personnel is only permitted with full extension of all outrigger beams. Use only National Crane approved baskets.
18. Operate controls slowly and smoothly to avoid damage to crane or personnel.
19. Boom must be in carrying rack and outriggers fully retracted for travel.
20. Maintain a clearance of at least 10 feet between any part of the crane, loadline or load and any electrical line carrying up to 50,000 volts. One foot additional clearance is required for every additional 30,000 volts or less.

DEFINITIONS

1. Load radius — Horizontal distance from the center line of rotation before loading to the center of the vertical loadline or block with load applied.
2. Load boom angle — Loaded boom angle is the angle between the first section boom and the horizontal, after lifting the rated load at the rated radius. The boom angle before loading should be greater to account for deflections. The loaded boom angle combined with the boom length give only an approximation of the operating radius.
3. Working area — Area measured in a circular arc above the center line of rotation as shown on the Working Area diagram.
4. Freely suspended load — Load hanging free with no direct external force applied except by the loadline.
5. Side load — Horizontal side force applied to the lifted load either on the ground or in the air.
6. No load stability limit — The stability limit radius shown on the range diagrams is the radius beyond which it is not permitted to position the boom plus block configuration because machine can overturn without any load on the hook.
7. Structural length limit — An area where the boom or the boom with jib deployed cannot be extended because of structural limitations.
8. PCSA — Power Crane and Shovel Association.

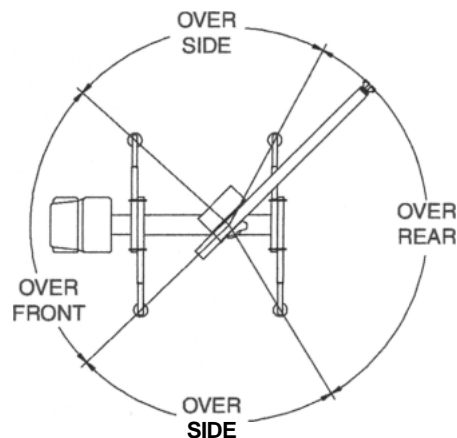

WORK AREA DIAGRAM

INFORMATIONAL DATA

OUTRIGGERS

1. Outrigger spread from center to center of outrigger floats at mid span is 14' and at full span is 20'.
2. No outrigger pad load exceeds 50,000 pounds maximum at full span or 60,000 pounds maximum at mid span.

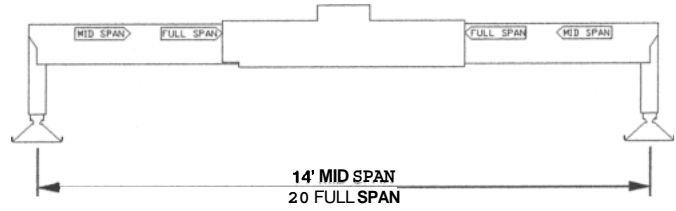

WEIGHT REDUCTIONS FOR LOAD HANDLING DEVICES (See load chart for jib deductions)

1. Hook blocks are rated at maximum capacity for the block. Do not exceed rated cable pull with any block

3.85 Ton	Downhaul Weight	150 lb
11.55 Ton	1 Sheave Block	305 lb
19.25 Ton	2 Sheave Block	355 lb
30.00 Ton	3 Sheave Block	575 lb

NOTICE

- Do not deadhead line block against boom tip when extending boom.
- Keep at least 3 wraps of loadline on drum at all times.
- Use only 9/16" diameter rotation resistant cable with 38,500 pounds breaking strength on this machine.

1 Part Line	2 Part Line	3 Part Line	4 Part Line	5 Part Line	6 Part Line	7 Part Line

Maximum boom length ± maximum elevation with rigging shown with load block ± ground level	95' & Jib	95'	79	54'	43'	36'	28
--	-----------	-----	----	-----	-----	-----	----

Winch	Cable Supplied	Average Breaking Strength	Lift and Speed	Lift and Speed	Lift and Speed	Lift and Speed	Lift and Speed	Lift and Speed	Lift and Speed
Standard Planetary Winch Low Speed	9/16" diameter rotation resistant 18x19 IWRC	38,500 lb	7,700 lb 164 fpm	15,400 lb 82 fpm	23,100 lb 55 fpm	30,800 lb 41 fpm	38,500 lb 33 fpm	46,200 lb 27 fpm	53,900 lb 23 fpm
Standard Planetary Winch High Speed	9/16" diameter rotation resistant 18 x 19 IWRC	38,500 lb	3,000lb 265 fpm	6,000 lb 132 fpm	9,000 lb 88 fpm	12,000 lb 66 fpm	15,000 lb 53 fpm	18,000 lb 44 fpm	21,000 lb 38 fpm

All winch pulls and speeds are shown on the fourth layer. Winch line pulls would increase on the first, second, and third layers. Winch line speed would decrease on the first, second, third and fourth layers. Winch line pulls may be limited by the winch capacity or the ANSI 5 to 1 cable safety factor. These are shown below:

Winch	Full Drum Pull	Allowable Cable Pull
Standard planetary	3,000 pounds (high speed) 7,700 pounds (low speed)	7,700 pounds

**1395
95' BOOM
44' JIB**

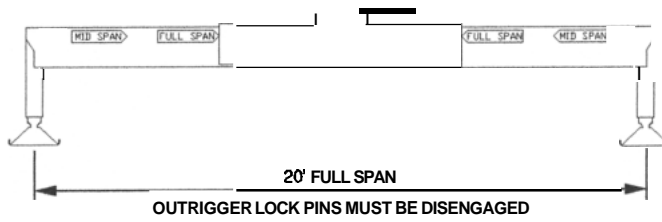

**FULL-SPAN
OUTRIGGER**

28 TO 95 FOOT BOOM RATED LOADS WITHOUT JIB

LOAD RADIUS (ft)	LOADED BOOM ANGLE	28 ft BOOM (lb)	LOADED BOOM ANGLE	43 ft BOOM (lb)	LOADED BOOM ANGLE	56 ft BOOM (lb)	LOADED BOOM ANGLE	69 ft BOOM (lb)	LOADED BOOM ANGLE	82 ft BOOM (lb)	ANGLE	
5	78.5	*60,000										
8	71.5	40,300										
10	67	33,700	76	30,500								
12	62.5	28,900	73.5	26,200	78	24,000						
14	57.5	25,400	70.5	23,000	76	21,000	79	19,000				
16	52	22,400	67.5	20,400	73.5	18,700	77.5	11,000	80	14,500		
20	40	17,700	61.5	16,700	69	15,300	74	13,900	77	12,500	79	10,200
25	17.5	11,800	53	13,500	63.5	12,400	69.5	11,400	73.5	10,500	76	9,000
30			43.5	11,000	57.5	10,400	65	9,600	69.5	8,900	73	8,000
35			32	8,800	50.5	8,800	60	8,200	66	7,500	70	7,000
40			15.5	6,200	44	7,500	55	7,100	62	6,600	66.5	6,100
45					35.5	6,100	50	5,950	58	5,650	63	5,300
50					24.5	4,900	43.5	4,950	53.5	4,750	59.5	4,600
55							37	4,100	48.5	4,000	56	4,000
60							28.5	3,350	43.5	3,400	52	3,400
65							16.5	2,600	37.5	2,800	47.5	2,850
70									31	2,300	43	2,350
75									22.5	1,900	38	1,950
80											32.5	1,550
85												1,250
90												
	0	6,200	0	2,900	0	1,450	0	650				

25 TO 44 FOOT JIB RATED LOADS

LOAD RADIUS (ft)	LOADED BOOM ANGLE	25 ft JIB (lb)	LOADED BOOM ANGLE	44 ft JIB (lb)
30	77	5,200	79.5	3,200
35	75	4,800	78	3,050
40	72.5	4,350	76	2,850
45	70	3,900	74	2,650
50	67.5	3,500	72	2,450
55	65	3,050	70	2,300
60	62	2,550	67	2,150
65	59	2,100	65	2,000
70	56	1,750	63	1,850
75	52.5	1,400	60.5	1,600
80	49.5	1,100	58	1,350
85	46	800	54.5	1,150
90	43	600	52	950
95			49	750
100			46	600

RATED LOAD REDUCTIONS WITH JIB

BOOM LENGTH	44' JIB STOWED
28'	Reduce load 600 lb
43'	Reduce load 400 lb
56'	Reduce load 300 lb
69'	Reduce load 300 lb
82'	Reduce load 200 lb
95'	Reduce load 200 lb

• See owners manual. Also the 60,000 lb load requires optional 9/16" diameter 6x25 IWRC cable.

Note:

1. All capacities are in pounds, angles in degrees, radius in feet.
2. Loaded boom angles are given as reference only.
3. Shaded areas are structurally limited capacities.
4. Handling of personnel is only permitted with full extension of all outrigger beams.

LMI OPERATING CODE

OPERATING MODE	
01	Main Boom - No jib Stowed
02	Main Boom - Jib Stowed
03	25 ft Tele Jib
04	44 ft Tele Jib
11	Man Basket on Main Boom
12	Man Basket on 25 ft Tele Jib
13	Man Basket on 44 ft Tele Jib

**1395
FULL-SPAN
OUTRIGGER 20'
95' BOOM 44' JIB**

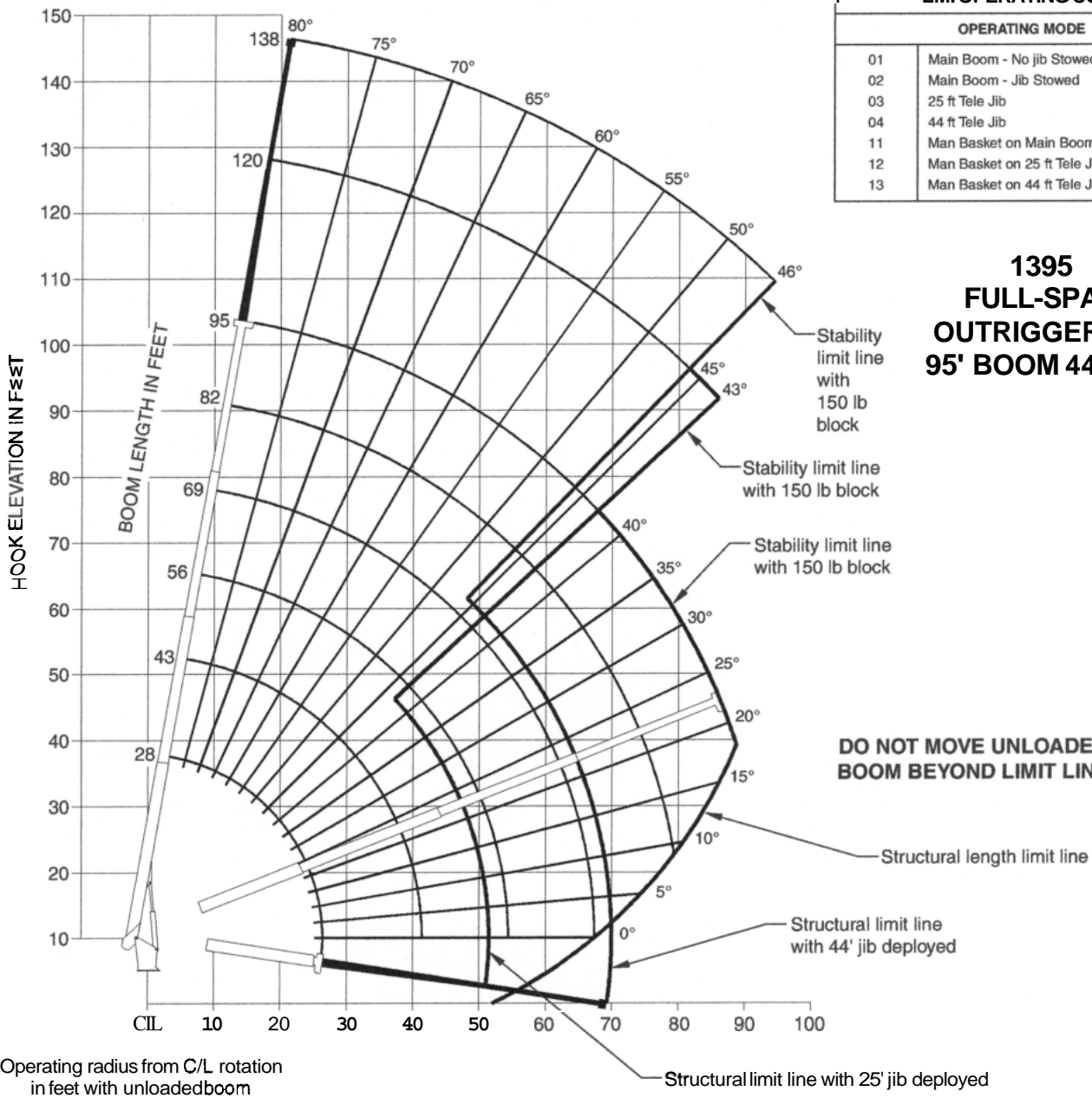

SET-UP

1. Fully extend and set outriggers to full-span location, level crane and set front stabilizer if equipped.

OPERATION

1. The 28 ft. boom length capacities are based on boom fully retracted. If not fully retracted, do not exceed 43 ft. boom length capacities.
2. Do not extend unloaded boom or jib beyond stability limit line on range chart as loss of stability may occur.
3. Load blocks and slings are considered to be a part of the load.
4. Operate with jib by radius when main boom is fully extended and by boom angle when main boom is partially extended. Do not exceed jib capacities at any partially extended boom length.
5. All jib loads must be lifted with single part reeving.

**1395
95' BOOM
44' JIB**

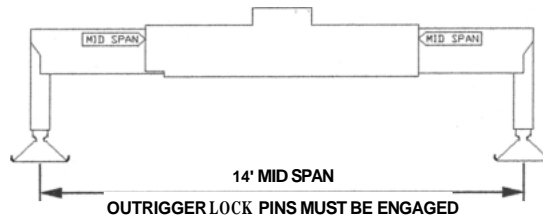

**MID-SPAN
OUTRIGGER**

LOAD RADIUS (ft)	LOADED BOOM ANGLE	28 ft BOOM (lb)	LOADED BOOM ANGLE	43 ft BOOM (lb)	LOADED BOOM ANGLE	56 ft BOOM (lb)	LOADED BOOM ANGLE	69 ft BOOM (lb)	LOADED BOOM ANGLE	82 ft BOOM (lb)	LOADED BOOM ANGLE	95 ft BOOM (lb)
5	78.5	*60,000										
8	71.5	40,300										
10	67	33,700	76	30,500								
12	62.5	28,900	73.5	26,200	78	24,000						
14	57.5	25,400	70.5	23,000	76	21,000	79	19,000				
16	51.9	19,600	67.5	20,400	73.5	18,700	77.5	17,000	80	14,500		
20	39.9	12,400	60.9	13,000	68.9	13,300	73.7	13,600	77	12,500	79	10,200
25	20.3	7,900	52.5	8,400	62.9	8,600	68.9	8,800	73	9,000	76	9,000
30			43.9	5,850	57.1	6,000	64.5	6,200	69.3	6,400	72.7	6,500
35			32.5	4,200	50.5	4,300	59.5	4,500	65.3	4,600	69.2	4,750
40			14.9	3,000	43.2	3,200	54.3	3,300	61.1	3,400	65.7	3,500
45					34.7	2,350	48.8	2,450	56.8	2,500	62.1	2,600
50					23.5	1,650	42.7	1,750	52.3	1,800	58.5	1,900
55							35.9	1,250	47.6	1,300	54.7	1,350
60							27.7	800	42.4	850	50.7	900
65									36.7	500	46.5	550
70												
75												
80												
85												
90												
95												
	0	6,200	0	2,800	0	1,200						

25 TO 44 FOOT JIB RATED LOADS

LOAD RADIUS (ft)	LOADED BOOM ANGLE	25 ft JIB (lb)	LOADED BOOM ANGLE	44 ft JIB (lb)
30	77.1	5,200	79.2	3,200
35	74.9	4,800	77.3	3,050
40	72	3,500	75.4	2,850
45	69.2	2,500	73.4	2,650
50	66.3	1,750	71.4	2,450
55	63.4	1,150	68.7	1,850
60	60.5	650	66.1	1,300
65			63.4	850
70			60.9	550
75				
80				
85				
90				
95				

RATED LOAD REDUCTIONS WITH JIB

BOOM LENGTH	44' JIB STOWED
28'	Reduce load 600 lb
43'	Reduce load 400 lb
--	
69'	Reduce load 300 lb
82'	Reduce load 200 lb
95'	Reduce load 200 lb

• See owners manual. Also the 60,000 lb load requires optional 9/16" diameter 6x25 IWRC cable.

Note:

1. All capacities are in pounds, angles in degrees, radius in feet.
2. Loaded boom angles are given as reference only.
3. Shaded areas are structurally limited capacities.
4. Handling of personnel is only permitted with full extension of all outrigger beams.

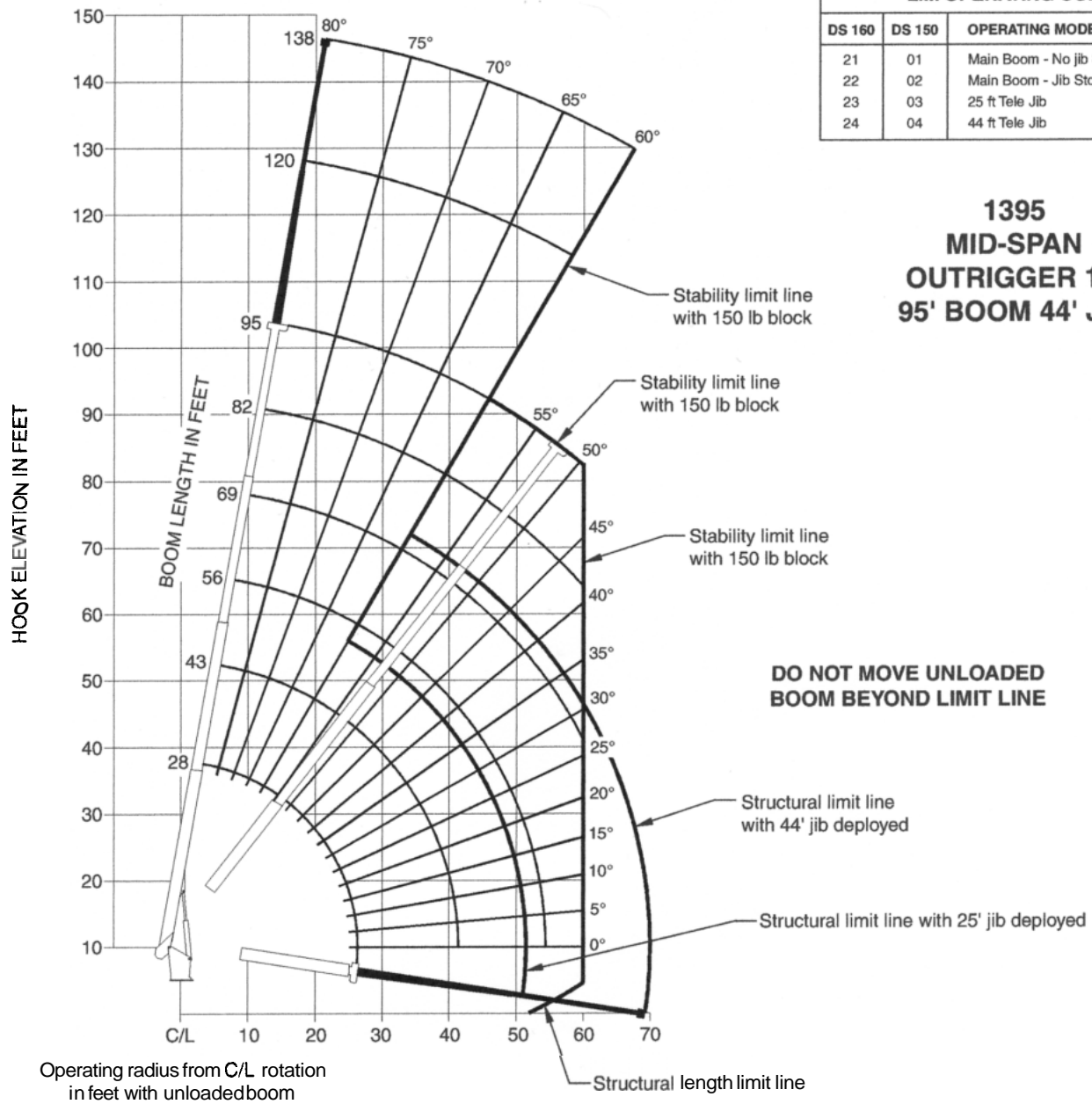

LMI OPERATING CODE		
DS 160	DS 150	OPERATING MODE
21	01	Main Boom - No jib Stowed
22	02	Main Boom - Jib Stowed
23	03	25 ft Tele Jib
24	04	44 ft Tele Jib

**1395
MID-SPAN
OUTRIGGER 14'
95' BOOM 44' JIB**

SET-UP

1. Engage mid-span outriggers lock pins, extend and set outrigger to mid-span location, level crane and set front stabilizer if equipped.

OPERATION

1. The 28 ft. boom length capacities are based on boom fully retracted. If not fully retracted, do not exceed 43 A. boom length capacities.
2. Do not extend unloaded boom or jib beyond stability limit line on range chart as loss of stability may occur.
3. Load blocks and slings are considered to be a part of the load.
4. Operate with jib by radius when main boom is fully extended and by boom angle when main boom is partially extended. Do not exceed jib capacities at any partially extended boom length.
5. All jib loads must be lifted with single part reeving.

DIMENSIONAL SPECIFICATIONS

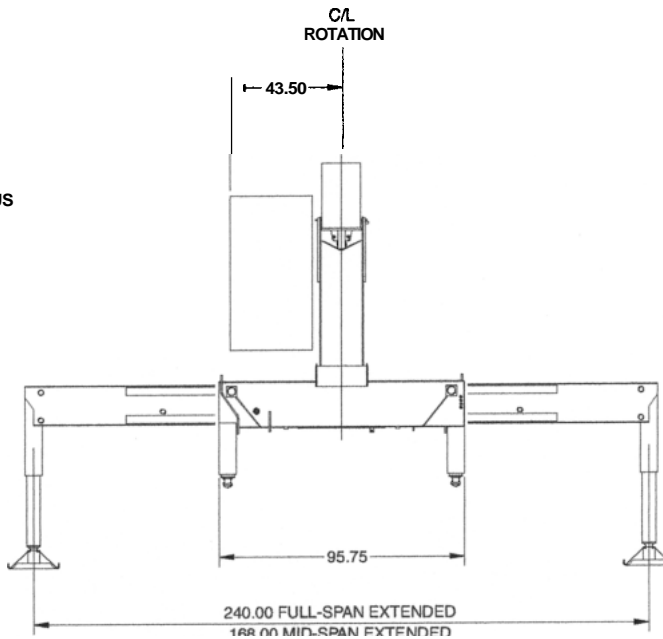
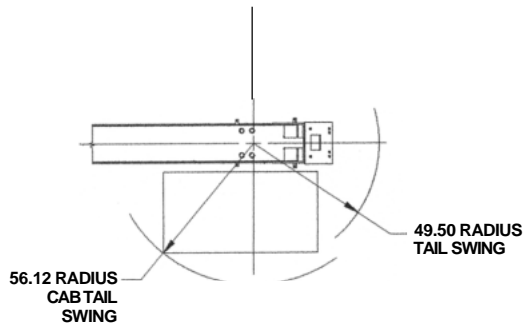
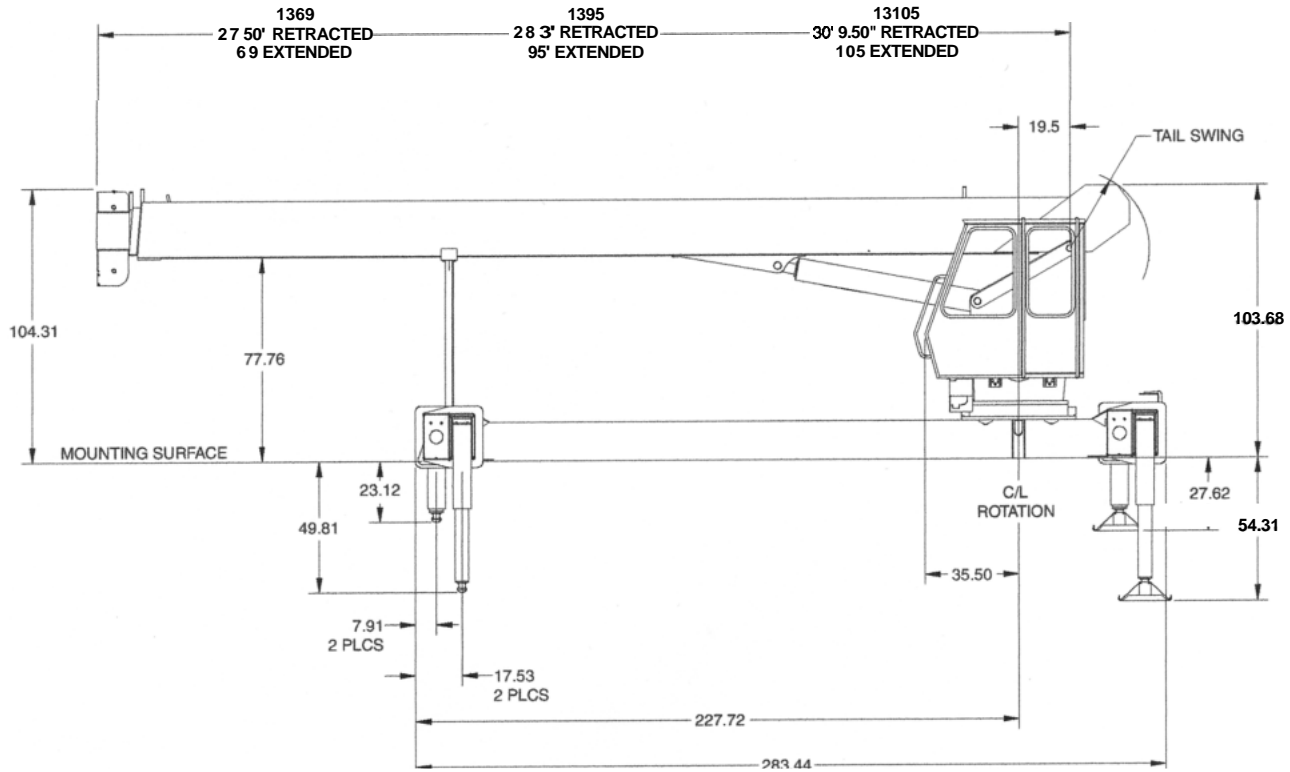

Note:
 All dimensions in inches
 unless otherwise noted.