

HK 40

40 METRISCHE TONNEN TRAGLAST / 40 METRIC TON CAPACITY

TRUCK CRANE



Maße (mm)
Dimensions (mm)

DIN/ISO/EN

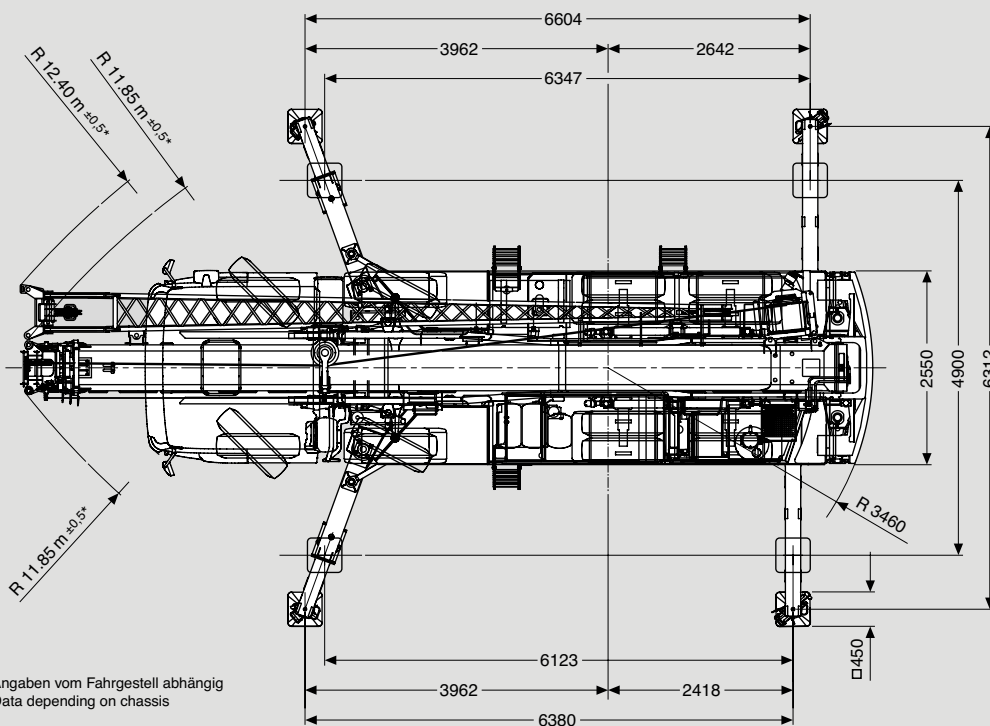
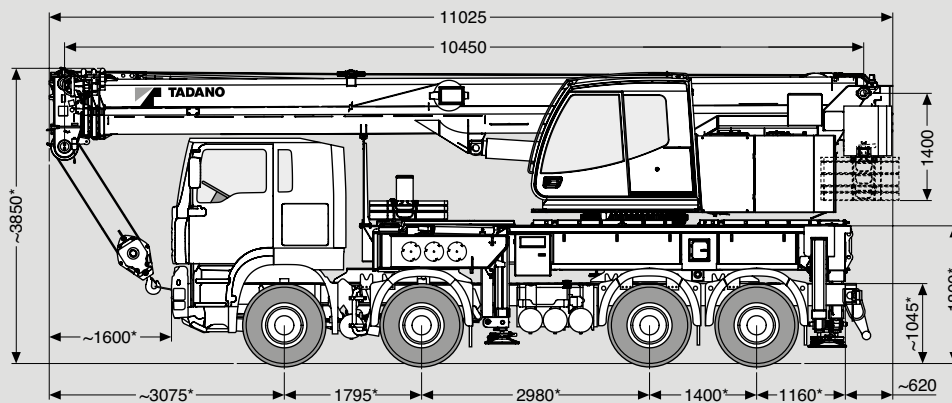
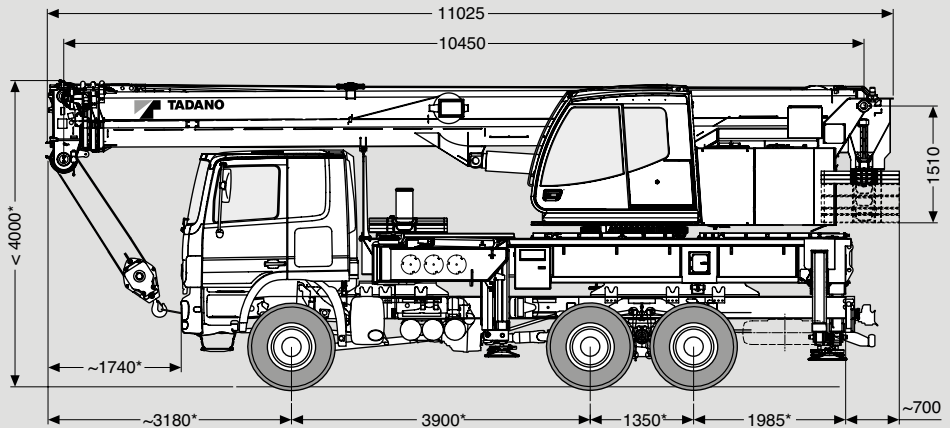



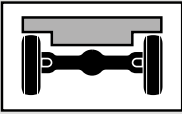
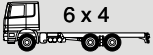
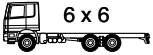
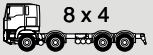

* Angaben vom Fahrgestell abhängig
* Data depending on chassis



	Achse / Axle	1	2	3	4	Gesamtgewicht / Total weight
	3-  (t) 6 x 4	9.0	9.5	9.5	–	26.0**
	3-  (t) 6 x 6	9.0	12.0	12.0	–	32.0*
	4-  (t) 8 x 4	8.0	8.0	9.5	9.5	32.0*

* Abhängig vom Fahrgestell und Optionen, incl. 4,5 t Gegengewicht, 9 m Auslegerverlängerung, 10 t Unterflasche, 4 t Hakengeschirr.
 * Depending on chassis and options, incl. 4.5 t counterweight, 9 m boom extension, 10 t hook block, 4 t swivel hook.
 ** Abhängig vom Fahrgestell und Optionen, incl. 9 m Auslegerverlängerung.
 ** Depending on chassis and options, incl. 9 m boom extension.

	Traglast / Lifting capacity	Rollen / Sheaves	Stränge / Parts of line	Gewicht / Weight
	30.6 t (Typ / Type / Typo 32)	5	9	280 kg
	17 t (Typ / Type / Typo 20)	3	5	200 kg
	6.8 t (Typ / Type / Typo 10)	1	2	150 kg
	3.4 t (Typ / Type / Typo 4)	–	1	75 kg

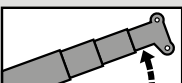
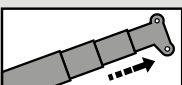

							
	Alle diese Daten abhängig vom Fahrgestell This data depending on chassis						
							
							

	Stufenlos Infinitely variable	Seil Rope	Max. Seilzug Max. single line pull
	0 - 135 m/min für einfachen Strang single line	14 mm / 150 m	33 kN
	0 - 2 min ⁻¹		
	- 0.5° – + 79° ca. 35 s approx. 35 s		
	10.5 m – 35.2 m ca. 105 s approx. 105 s		

Hubhöhen
Lifting heights



DIN/ISO/EN

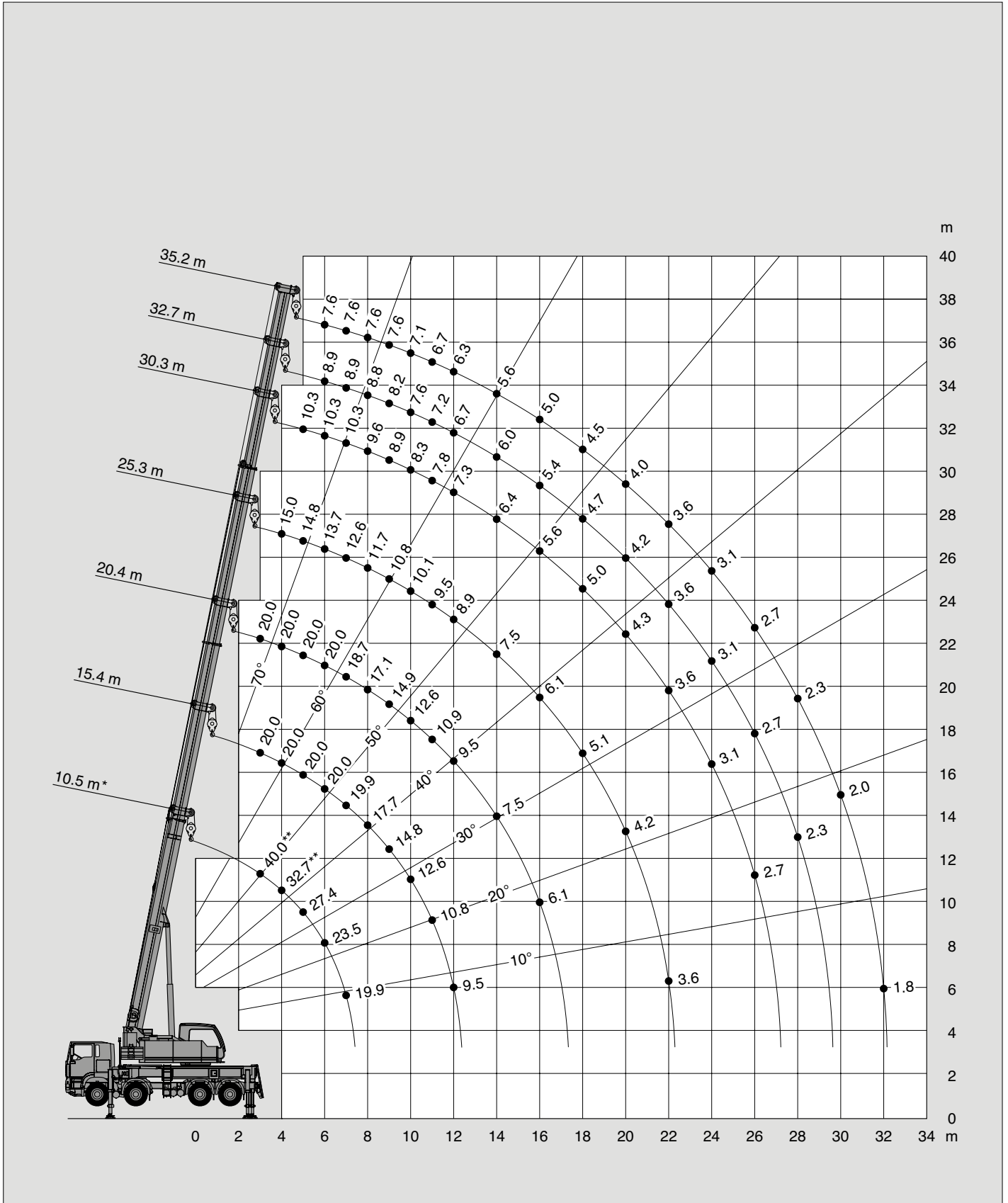





8.5 t

+



DIN/ISO/EN

 m	10.5 m*	10.5 m	15.4 m	20.4 m	25.3 m	30.3 m	32.7 m	35.2 m
3.0	40.0**	35.0**	20.0	20.0	15.0			
3.5	36.0**	32.4**	20.0	20.0	15.0			
4.0	32.7**	29.8	20.0	20.0	15.0			
4.5	29.9	27.6	20.0	20.0	15.0	10.3		
5.0	27.4	25.3	20.0	20.0	14.8	10.3		
6.0	23.5	21.8	20.0	20.0	13.7	10.3	8.9	7.6
7.0	19.9	19.7	19.9	18.7	12.6	10.3	8.9	7.6
8.0			17.7	17.1	11.7	9.6	8.8	7.6
9.0			14.8	14.9	10.8	8.9	8.2	7.6
10.0			12.6	12.6	10.1	8.3	7.6	7.1
11.0			10.8	10.9	9.5	7.8	7.2	6.7
12.0			9.5	9.5	8.9	7.3	6.7	6.3
14.0				7.5	7.5	6.4	6.0	5.6
16.0				6.1	6.1	5.6	5.4	5.0
18.0					5.1	5.0	4.7	4.5
20.0					4.2	4.3	4.2	4.0
22.0					3.6	3.6	3.6	3.6
24.0						3.1	3.1	3.1
26.0						2.7	2.7	2.7
28.0							2.3	2.3
30.0								2.0
32.0								1.8

* Nach hinten / * Over rear

** Mit Zusatzhubausrüstung / ** With additional lifting equipment

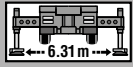
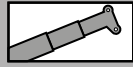
Hubhöhen
Lifting heights



4.5t

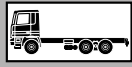

DIN/ISO/EN

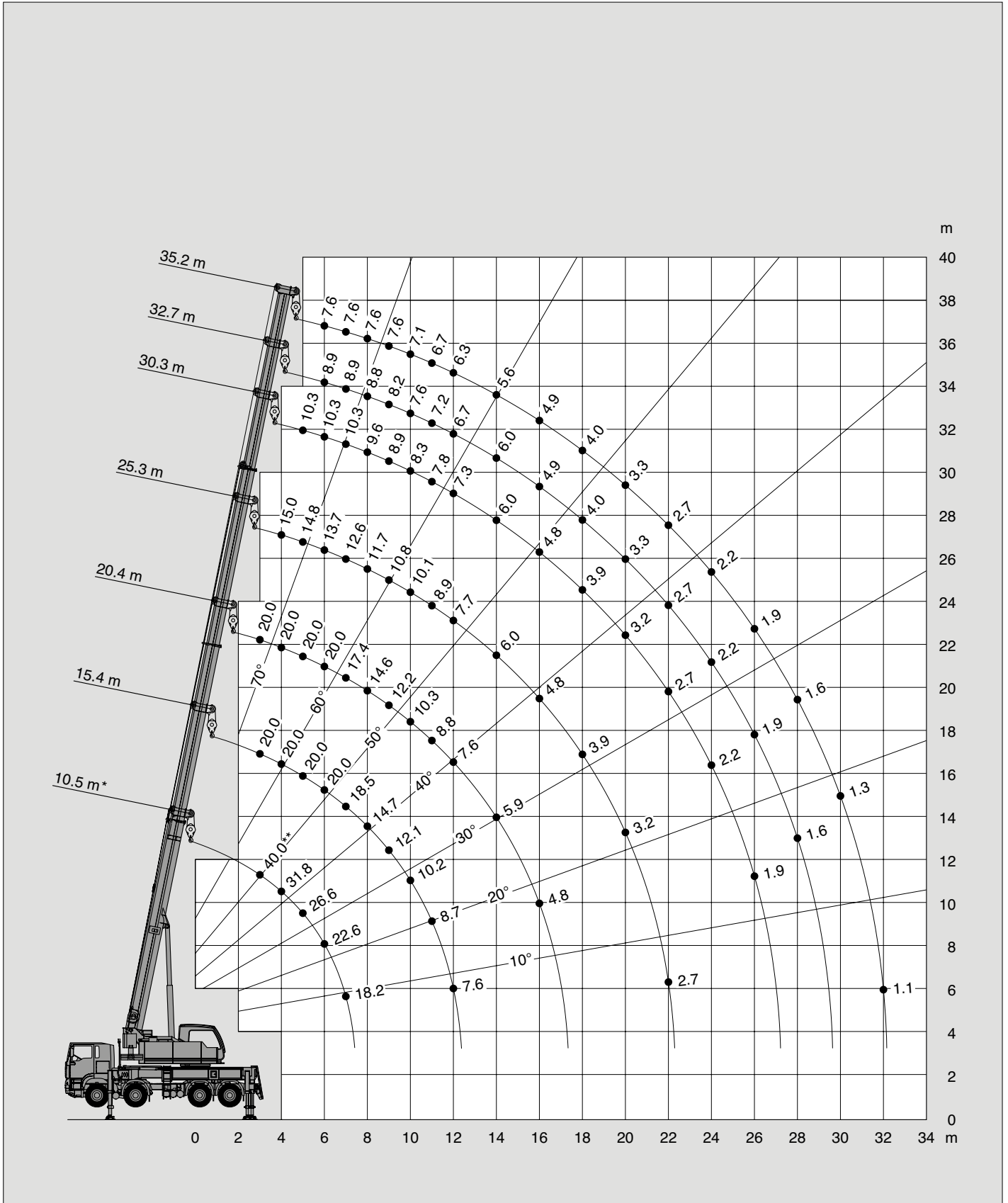





4.5 t

+

DIN/ISO/EN

 m	10.5 m*	10.5 m	15.4 m	20.4 m	25.3 m	30.3 m	32.7 m	35.2 m
3.0	40.0**	35.0**	20.0	20.0	15.0			
3.5	35.1**	31.6	20.0	20.0	15.0			
4.0	31.8	29.0	20.0	20.0	15.0			
4.5	29.0	26.8	20.0	20.0	15.0	10.3		
5.0	26.6	24.5	20.0	20.0	14.8	10.3		
6.0	22.6	21.0	20.0	20.0	13.7	10.3	8.9	7.6
7.0	18.2	18.2	18.5	17.4	12.6	10.3	8.9	7.6
8.0			14.7	14.6	11.7	9.6	8.8	7.6
9.0			12.1	12.2	10.8	8.9	8.2	7.6
10.0			10.2	10.3	10.1	8.3	7.6	7.1
11.0			8.7	8.8	8.9	7.8	7.2	6.7
12.0			7.6	7.6	7.7	7.3	6.7	6.3
14.0				5.9	6.0	6.0	6.0	5.6
16.0				4.8	4.8	4.8	4.9	4.9
18.0					3.9	3.9	4.0	4.0
20.0					3.2	3.2	3.3	3.3
22.0					2.7	2.7	2.7	2.7
24.0						2.2	2.2	2.2
26.0						1.9	1.9	1.9
28.0							1.6	1.6
30.0								1.3
32.0								1.1

* Nach hinten / * Over rear

** Mit Zusatzhubausrüstung / ** With additional lifting equipment

Hubhöhen
Lifting heights



DIN/ISO/EN

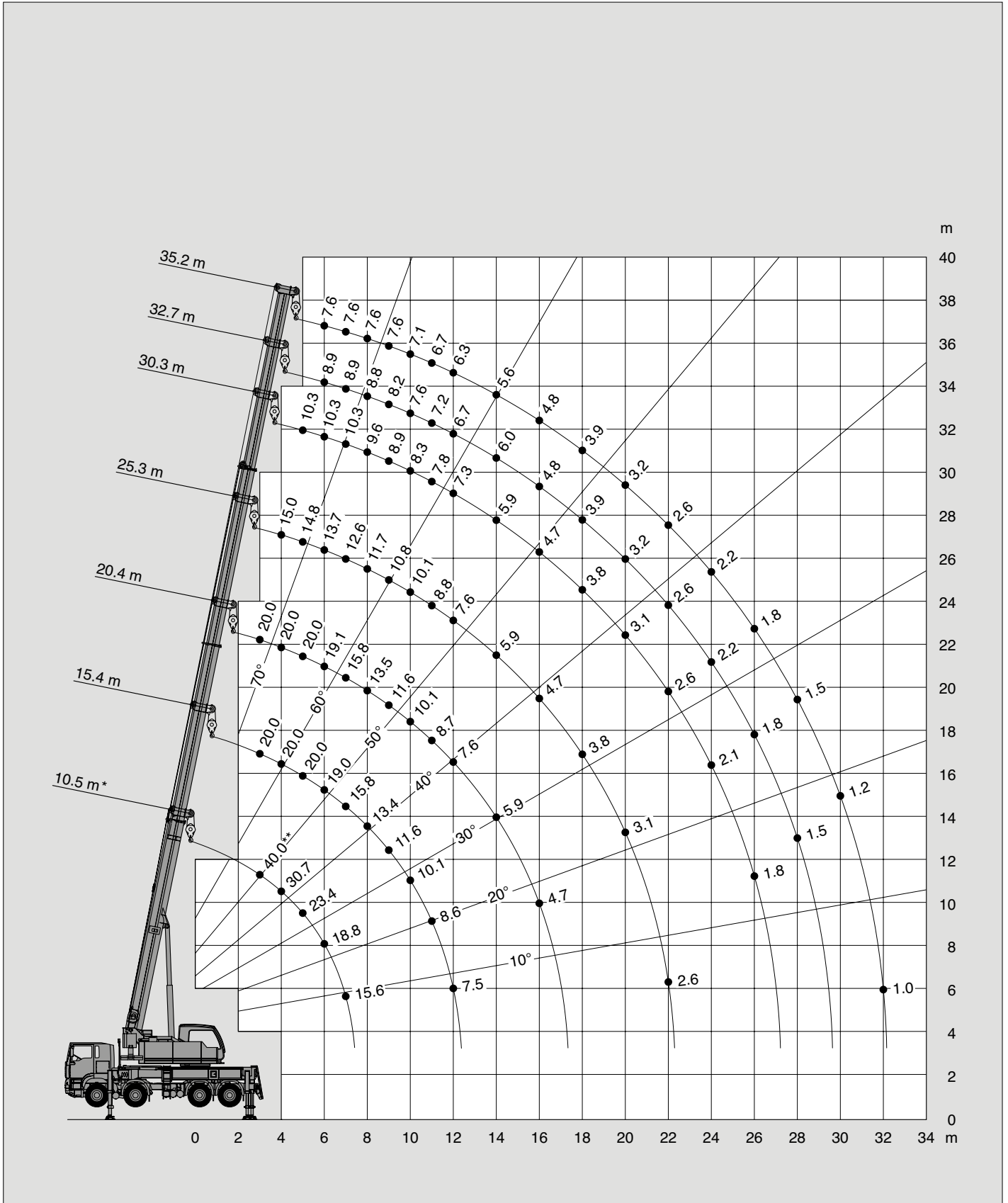





3.8 t

+

DIN/ISO/EN

 m	10.5 m*	10.5 m	15.4 m	20.4 m	25.3 m	30.3 m	32.7 m	35.2 m
3.0	40.0**	35.0**	20.0	20.0	15.0			
3.5	35.1**	31.8	20.0	20.0	15.0			
4.0	30.7	29.0	20.0	20.0	15.0			
4.5	26.6	26.6	20.0	20.0	15.0	10.3		
5.0	23.4	23.4	20.0	20.0	14.8	10.3		
6.0	18.8	18.8	19.0	19.1	13.7	10.3	8.9	7.6
7.0	15.6	15.6	15.8	15.8	12.6	10.3	8.9	7.6
8.0			13.4	13.5	11.7	9.6	8.8	7.6
9.0			11.6	11.6	10.8	8.9	8.2	7.6
10.0			10.1	10.1	10.1	8.3	7.6	7.1
11.0			8.6	8.7	8.8	7.8	7.2	6.7
12.0			7.5	7.6	7.6	7.3	6.7	6.3
14.0				5.9	5.9	5.9	6.0	5.6
16.0				4.7	4.7	4.7	4.8	4.8
18.0					3.8	3.8	3.9	3.9
20.0					3.1	3.1	3.2	3.2
22.0					2.6	2.6	2.6	2.6
24.0						2.1	2.2	2.2
26.0						1.8	1.8	1.8
28.0							1.5	1.5
30.0								1.2
32.0								1.0

* Nach hinten / * Over rear

** Mit Zusatzhubausrüstung / ** With additional lifting equipment

Hubhöhen
Lifting heights



DIN/ISO/EN

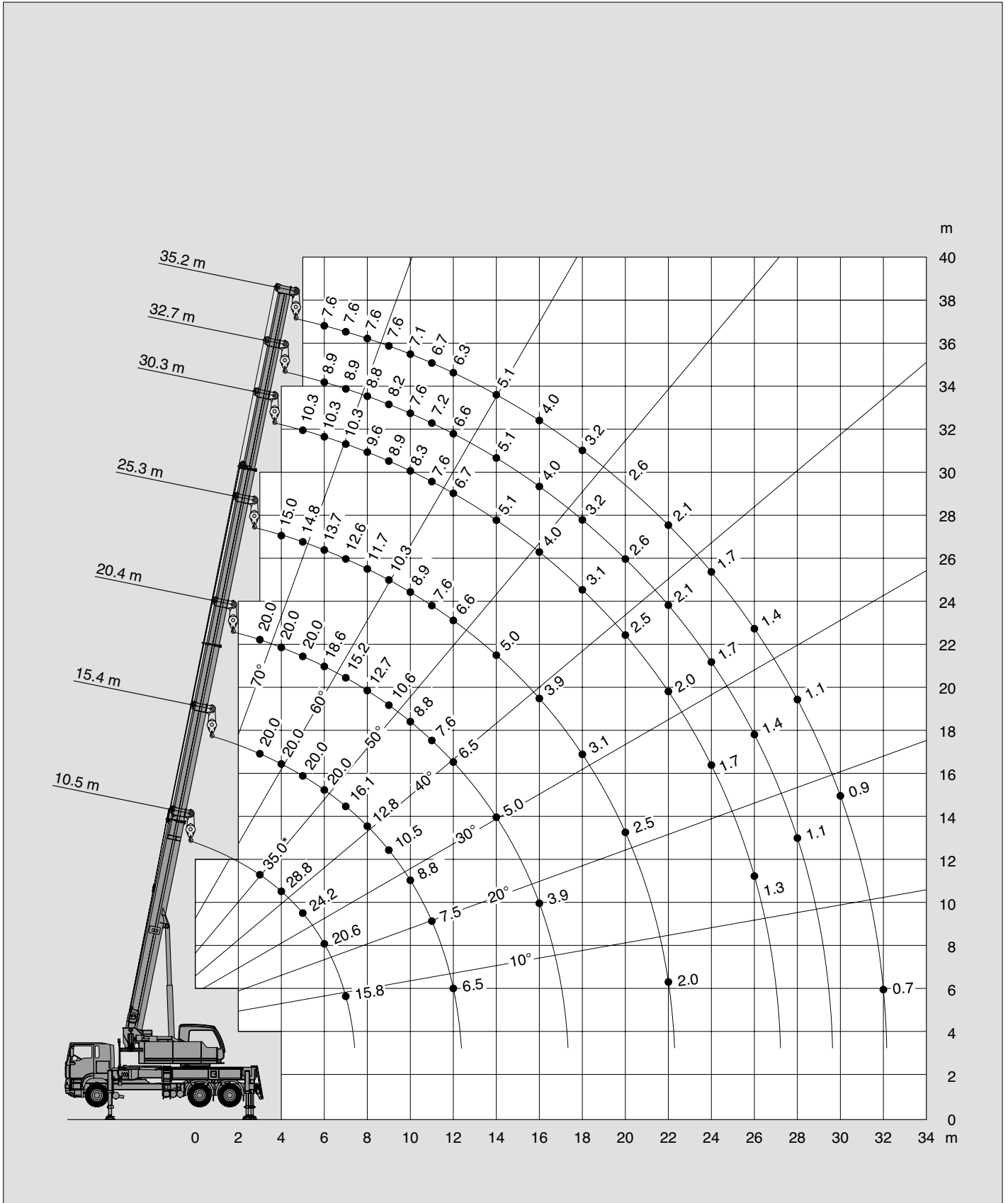





2.1 t



DIN/ISO/EN

 m	10.5 m	15.4 m	20.4 m	25.3 m	30.3 m	32.7 m	35.2 m
3.0	35.0*	20.0	20.0	15.0			
3.5	31.5	20.0	20.0	15.0			
4.0	28.8	20.0	20.0	15.0			
4.5	26.4	20.0	20.0	15.0	10.3		
5.0	24.2	20.0	20.0	14.8	10.3		
6.0	20.6	20.0	18.6	13.7	10.3	8.9	7.6
7.0	15.8	16.1	15.2	12.6	10.3	8.9	7.6
8.0		12.8	12.7	11.7	9.6	8.8	7.6
9.0		10.5	10.6	10.3	8.9	8.2	7.6
10.0		8.8	8.8	8.9	8.3	7.6	7.1
11.0		7.5	7.6	7.6	7.6	7.2	6.7
12.0		6.5	6.5	6.6	6.7	6.6	6.3
14.0			5.0	5.0	5.1	5.1	5.1
16.0			3.9	3.9	4.0	4.0	4.0
18.0				3.1	3.1	3.2	3.2
20.0				2.5	2.5	2.6	2.6
22.0				2.0	2.0	2.1	2.1
24.0					1.7	1.7	1.7
26.0					1.3	1.4	1.4
28.0						1.1	1.1
30.0							0.9
32.0							0.7

* Mit Zusatzhubausrüstung / * With additional lifting equipment

Hubhöhen
Lifting heights

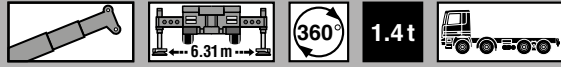

DIN/ISO/EN

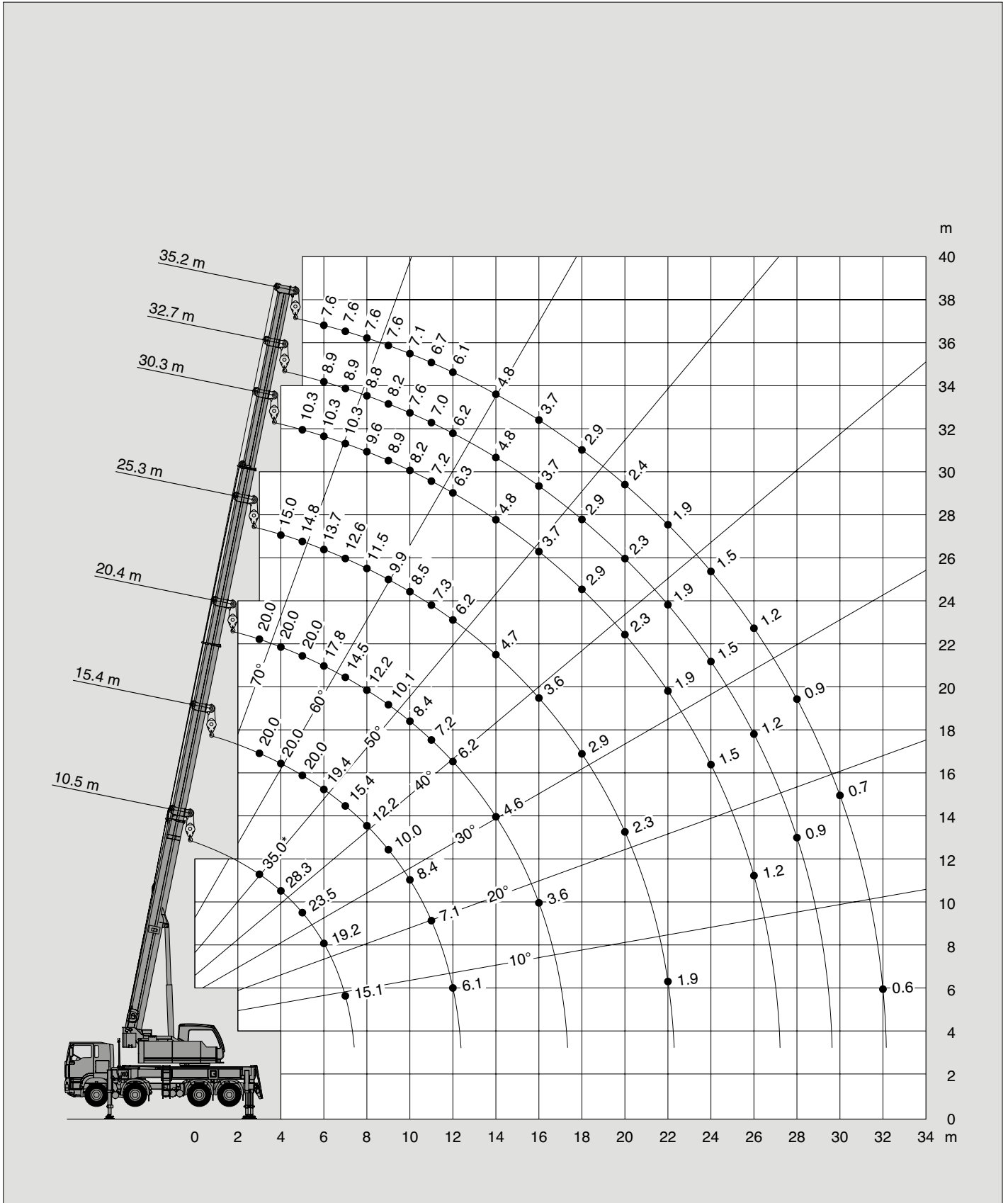







1.4 t



DIN/ISO/EN

 m	10.5 m	15.4 m	20.4 m	25.3 m	30.3 m	32.7 m	35.2 m
3.0	35.0*	20.0	20.0	15.0			
3.5	31.1	20.0	20.0	15.0			
4.0	28.3	20.0	20.0	15.0			
4.5	26.1	20.0	20.0	15.0	10.3		
5.0	23.5	20.0	20.0	14.8	10.3		
6.0	19.2	19.4	17.8	13.7	10.3	8.9	7.6
7.0	15.1	15.4	14.5	12.6	10.3	8.9	7.6
8.0		12.2	12.2	11.5	9.6	8.8	7.6
9.0		10.0	10.1	9.9	8.9	8.2	7.6
10.0		8.4	8.4	8.5	8.2	7.6	7.1
11.0		7.1	7.2	7.3	7.2	7.0	6.7
12.0		6.1	6.2	6.2	6.3	6.2	6.1
14.0			4.6	4.7	4.8	4.8	4.8
16.0			3.6	3.6	3.7	3.7	3.7
18.0				2.9	2.9	2.9	2.9
20.0				2.3	2.3	2.3	2.4
22.0				1.9	1.9	1.9	1.9
24.0					1.5	1.5	1.5
26.0					1.2	1.2	1.2
28.0						0.9	0.9
30.0							0.7
32.0							0.6

* Mit Zusatzhubausrüstung / * With additional lifting equipment

Hubhöhen
Lifting heights



DIN/ISO/EN

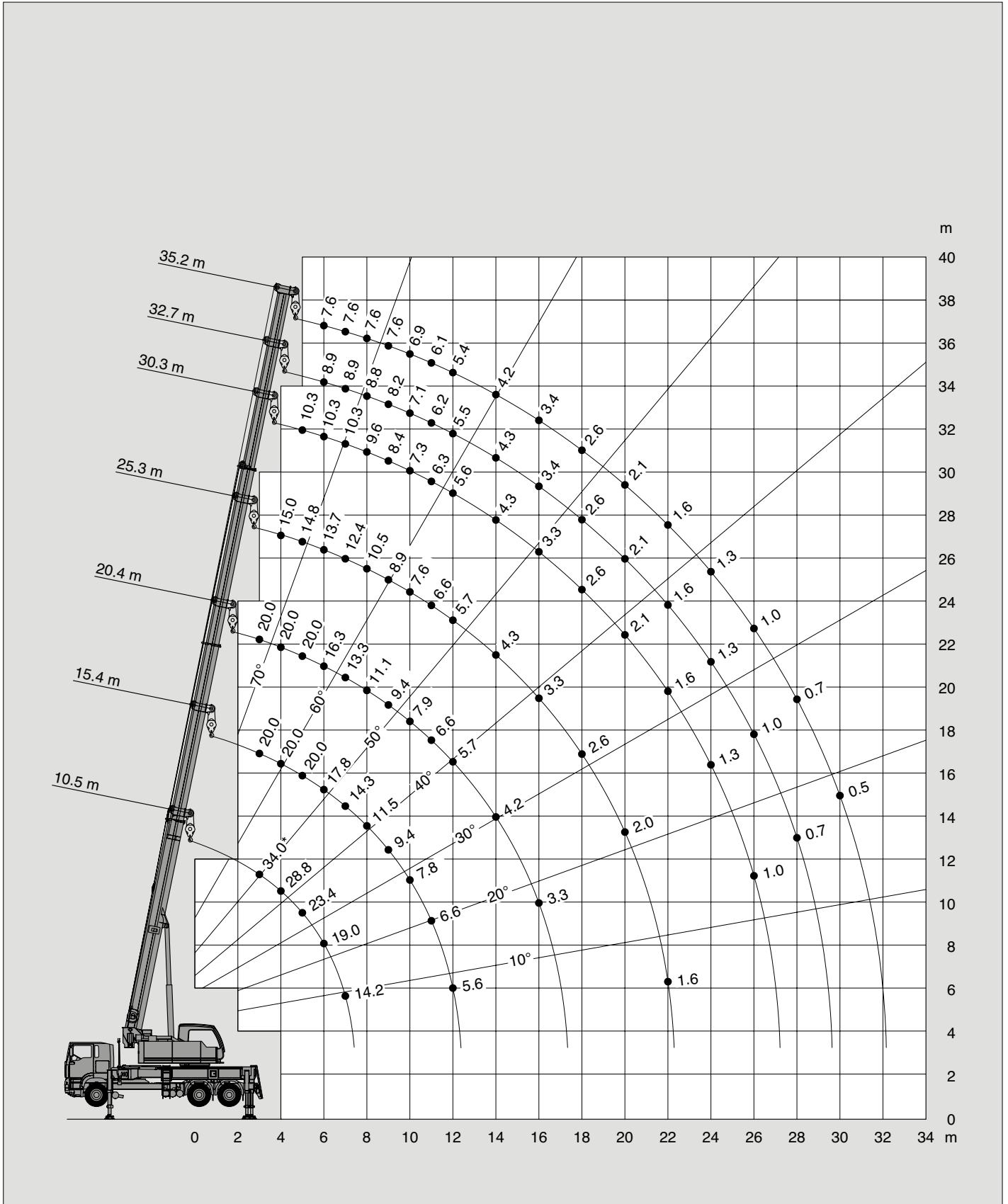





0t



DIN/ISO/EN

 m	10.5 m	15.4 m	20.4 m	25.3 m	30.3 m	32.7 m	35.2 m
3.0	34.0*	20.0	20.0	15.0			
3.5	31.0	20.0	20.0	15.0			
4.0	28.8	20.0	20.0	15.0			
4.5	26.1	20.0	20.0	15.0	10.3		
5.0	23.4	20.0	20.0	14.8	10.3		
6.0	19.0	17.8	16.3	13.7	10.3	8.9	7.6
7.0	14.2	14.3	13.3	12.4	10.3	8.9	7.6
8.0		11.5	11.1	10.5	9.6	8.8	7.6
9.0		9.4	9.4	8.9	8.4	8.2	7.6
10.0		7.8	7.9	7.6	7.3	7.1	6.9
11.0		6.6	6.6	6.6	6.3	6.2	6.1
12.0		5.6	5.7	5.7	5.6	5.5	5.4
14.0			4.2	4.3	4.3	4.3	4.2
16.0			3.3	3.3	3.3	3.4	3.4
18.0				2.6	2.6	2.6	2.6
20.0				2.0	2.1	2.1	2.1
22.0				1.6	1.6	1.6	1.6
24.0					1.3	1.3	1.3
26.0					1.0	1.0	1.0
28.0						0.7	0.7
30.0							0.5

* Mit Zusatzhubausrüstung / * With additional lifting equipment

Hubhöhen
Lifting heights



DIN/ISO/EN

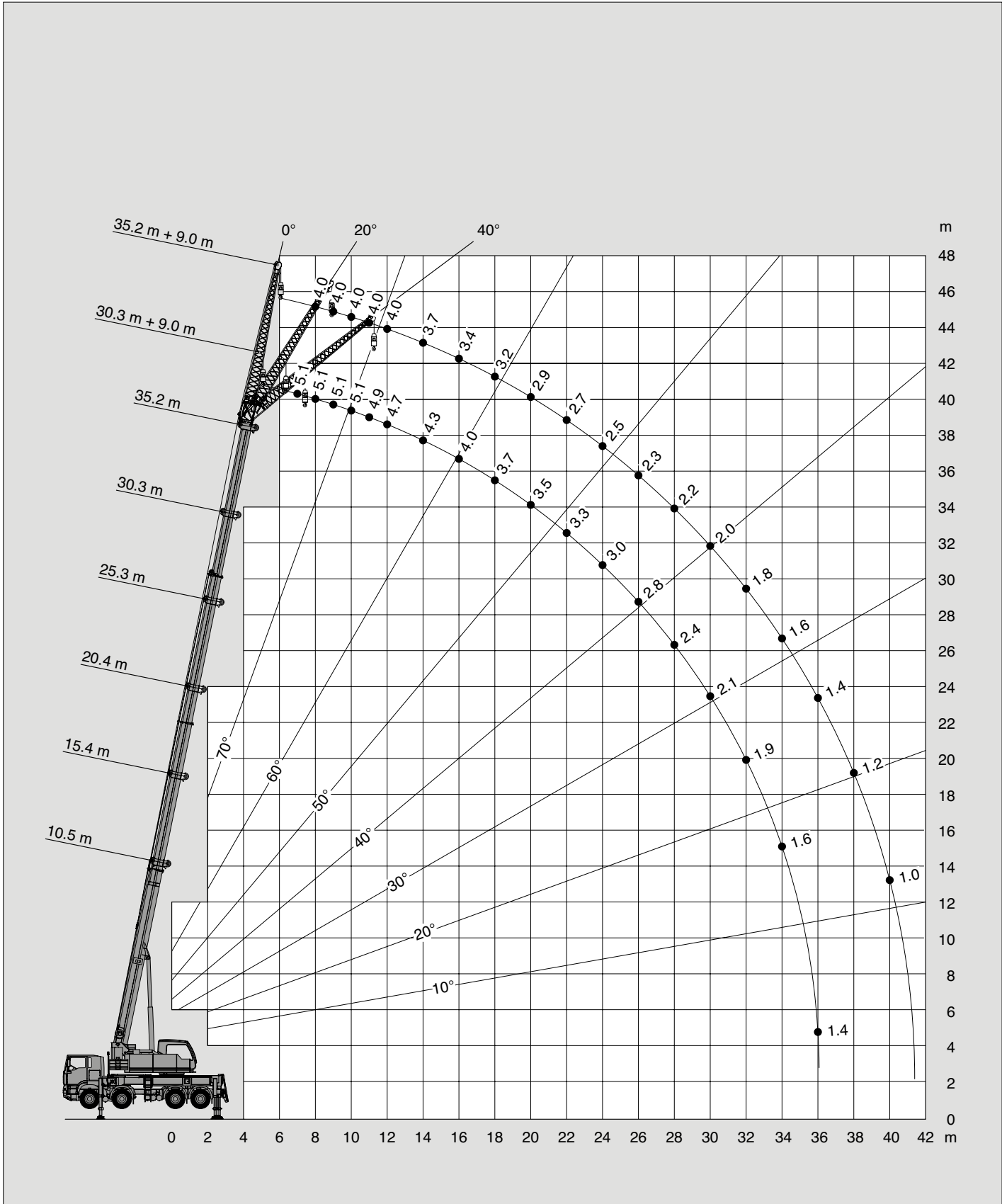

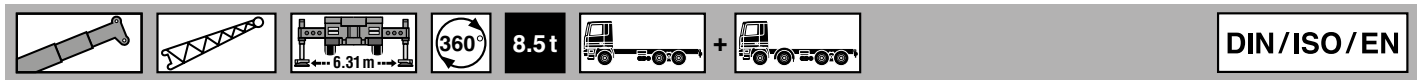

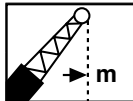
 m	10.5 m + 9.0 m			30.3 m + 9.0 m			35.2 m + 9.0 m		
	0°	20°	40°	0°	20°	40°	0°	20°	40°
3.0	6.5								
3.5	6.5								
4.0	6.5	6.5							
4.5	6.5	6.5							
5.0	6.5	6.4							
6.0	6.5	6.0		5.1					
7.0	6.5	5.6	4.7	5.1					
8.0	6.4	5.4	4.5	5.1			4.0		
9.0	6.0	5.1	4.4	5.1	4.6		4.0		
10.0	5.6	4.9	4.2	5.1	4.4		4.0		
11.0	5.3	4.6	4.1	4.9	4.2		4.0	3.7	
12.0	5.0	4.4	4.0	4.7	4.1	3.8	4.0	3.5	
14.0	4.6	4.1	3.9	4.3	3.8	3.5	3.7	3.3	3.1
16.0	4.2	4.0		4.0	3.6	3.3	3.4	3.1	2.9
18.0				3.7	3.4	3.2	3.2	2.9	2.8
20.0				3.5	3.2	3.0	2.9	2.8	2.6
22.0				3.3	3.0	2.9	2.7	2.6	2.5
24.0				3.0	2.9	2.8	2.5	2.5	2.4
26.0				2.8	2.8	2.7	2.3	2.3	2.3
28.0				2.4	2.6	2.6	2.2	2.2	2.2
30.0				2.1	2.2	2.3	2.0	2.0	2.0
32.0				1.9	1.9		1.8	1.9	1.9
34.0				1.6	1.7		1.6	1.7	1.7
36.0				1.4			1.4	1.4	
38.0							1.2	1.2	
40.0							1.0	1.0	

Hubhöhen
Lifting heights

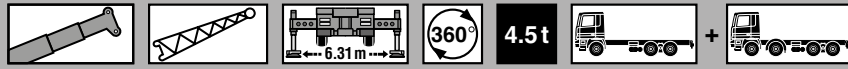

DIN/ISO/EN

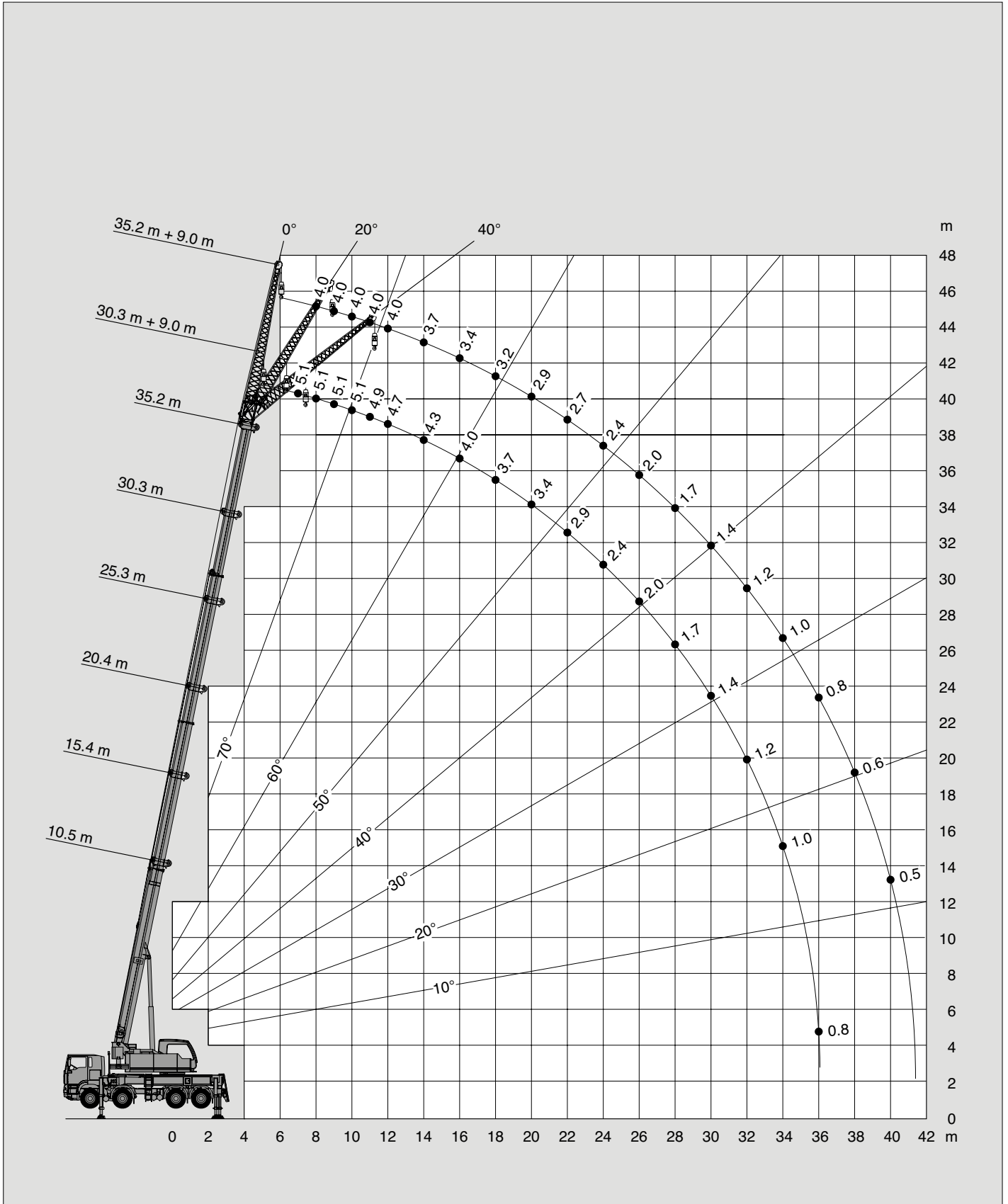

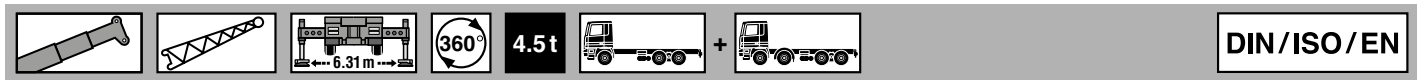

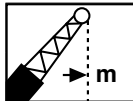
	10.5 m + 9.0 m			30.3 m + 9.0 m			35.2 m + 9.0 m		
	0°	20°	40°	0°	20°	40°	0°	20°	40°
3.0	6.5								
3.5	6.5								
4.0	6.5	6.5							
4.5	6.5	6.5							
5.0	6.5	6.4							
6.0	6.5	6.0		5.1					
7.0	6.5	5.6	4.7	5.1					
8.0	6.4	5.4	4.5	5.1			4.0		
9.0	6.0	5.1	4.4	5.1	4.6		4.0		
10.0	5.6	4.9	4.2	5.1	4.4		4.0		
11.0	5.3	4.6	4.1	4.9	4.2		4.0	3.7	
12.0	5.0	4.4	4.0	4.7	4.1	3.8	4.0	3.5	
14.0	4.6	4.1	3.9	4.3	3.8	3.5	3.7	3.3	3.1
16.0	4.2	4.0		4.0	3.6	3.3	3.4	3.1	2.9
18.0				3.7	3.4	3.2	3.2	2.9	2.8
20.0				3.4	3.2	3.0	2.9	2.8	2.6
22.0				2.9	3.0	2.9	2.7	2.6	2.5
24.0				2.4	2.6	2.7	2.4	2.5	2.4
26.0				2.0	2.2	2.3	2.0	2.2	2.3
28.0				1.7	1.8	1.9	1.7	1.8	1.9
30.0				1.4	1.5	1.6	1.4	1.5	1.6
32.0				1.2	1.3		1.2	1.3	1.3
34.0				1.0	1.0		1.0	1.0	1.1
36.0				0.8			0.8	0.8	
38.0							0.6	0.7	
40.0							0.5	0.5	

Hubhöhen
Lifting heights

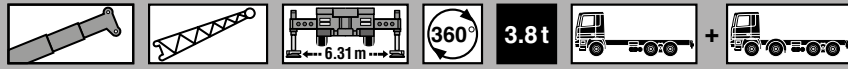

DIN/ISO/EN

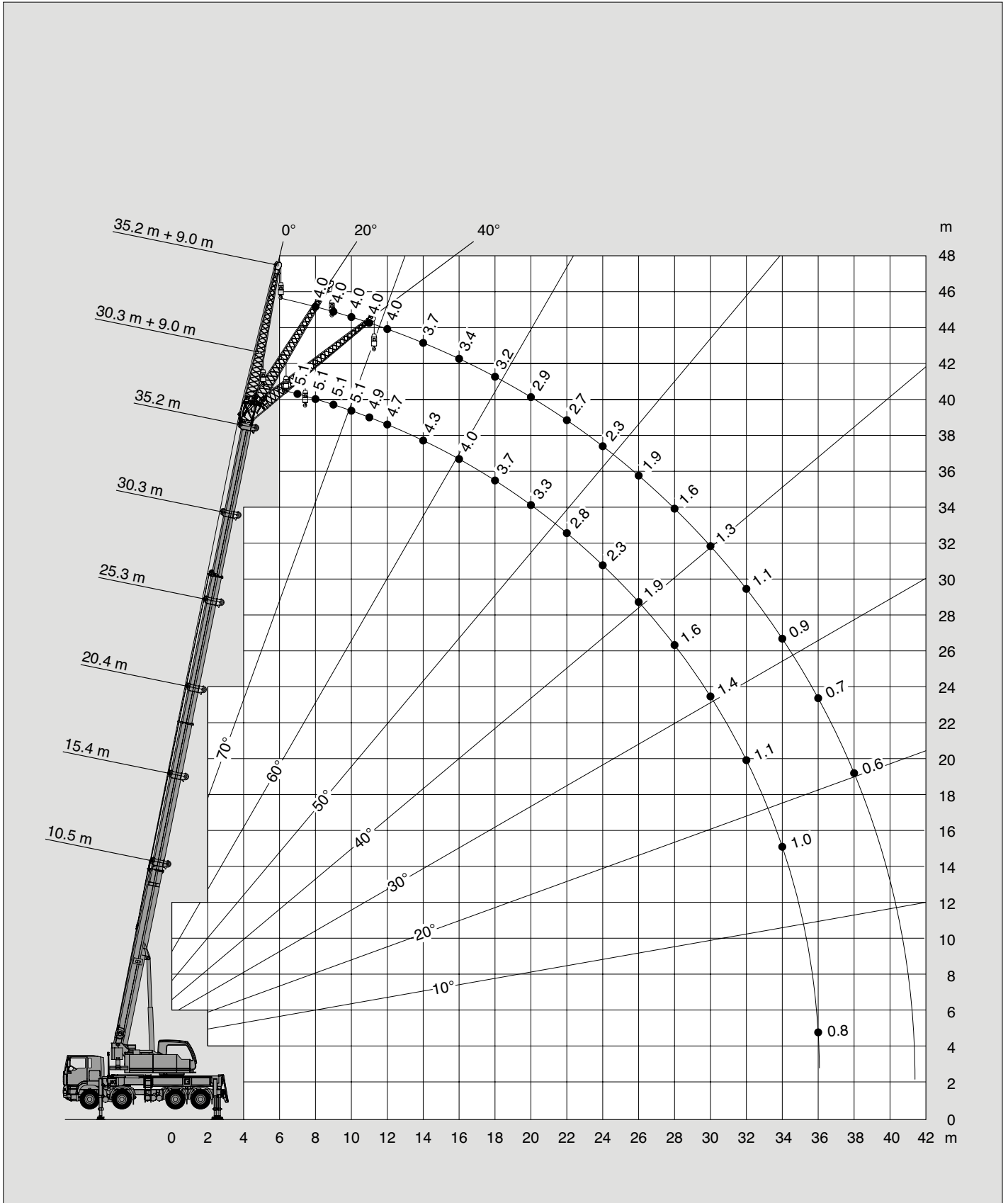

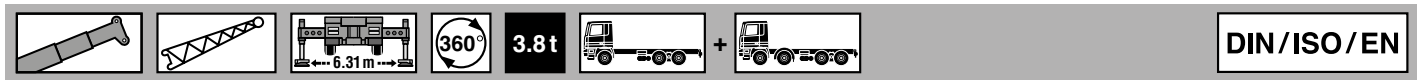

DIN/ISO/EN

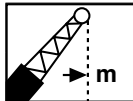
	10.5 m + 9.0 m			30.3 m + 9.0 m			35.2 m + 9.0 m		
	0°	20°	40°	0°	20°	40°	0°	20°	40°
3.0	6.5								
3.5	6.5								
4.0	6.5	6.5							
4.5	6.5	6.5							
5.0	6.5	6.4							
6.0	6.5	6.0		5.1					
7.0	6.5	5.6	4.7	5.1					
8.0	6.4	5.4	4.5	5.1			4.0		
9.0	6.0	5.1	4.4	5.1	4.6		4.0		
10.0	5.6	4.9	4.2	5.1	4.4		4.0		
11.0	5.3	4.6	4.1	4.9	4.2		4.0	3.7	
12.0	5.0	4.4	4.0	4.7	4.1	3.8	4.0	3.5	
14.0	4.6	4.1	3.9	4.3	3.8	3.5	3.7	3.3	3.1
16.0	4.2	4.0		4.0	3.6	3.3	3.4	3.1	2.9
18.0				3.7	3.4	3.2	3.2	2.9	2.8
20.0				3.3	3.2	3.0	2.9	2.8	2.6
22.0				2.8	3.0	2.9	2.7	2.6	2.5
24.0				2.3	2.5	2.6	2.3	2.5	2.4
26.0				1.9	2.1	2.2	1.9	2.1	2.2
28.0				1.6	1.8	1.8	1.6	1.7	1.8
30.0				1.4	1.5	1.5	1.3	1.5	1.5
32.0				1.1	1.2		1.1	1.2	1.3
34.0				1.0	1.0		0.9	1.0	1.0
36.0				0.8			0.7	0.8	
38.0							0.6	0.6	
40.0									

Gegengewichtvarianten Counterweight versions

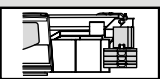
	DIN/ISO/EN					
	Gegengewicht / Counterweight	3 x	2 x	1 x	1 x	1 x
		①	②	③	④	⑤
	(t)	0.7	2.0	1.0	1.2	0.2

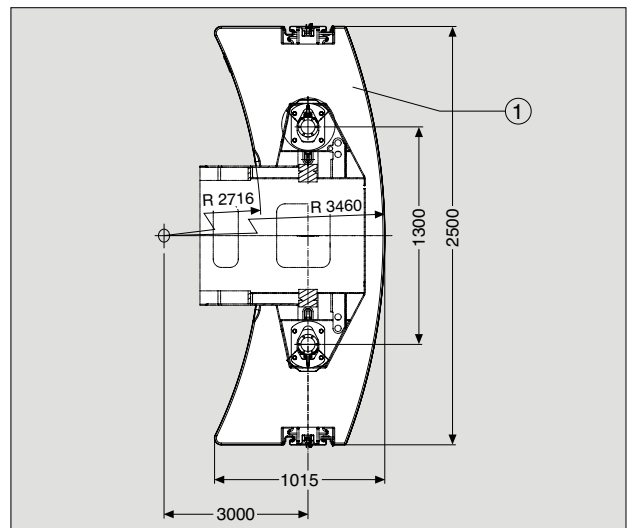
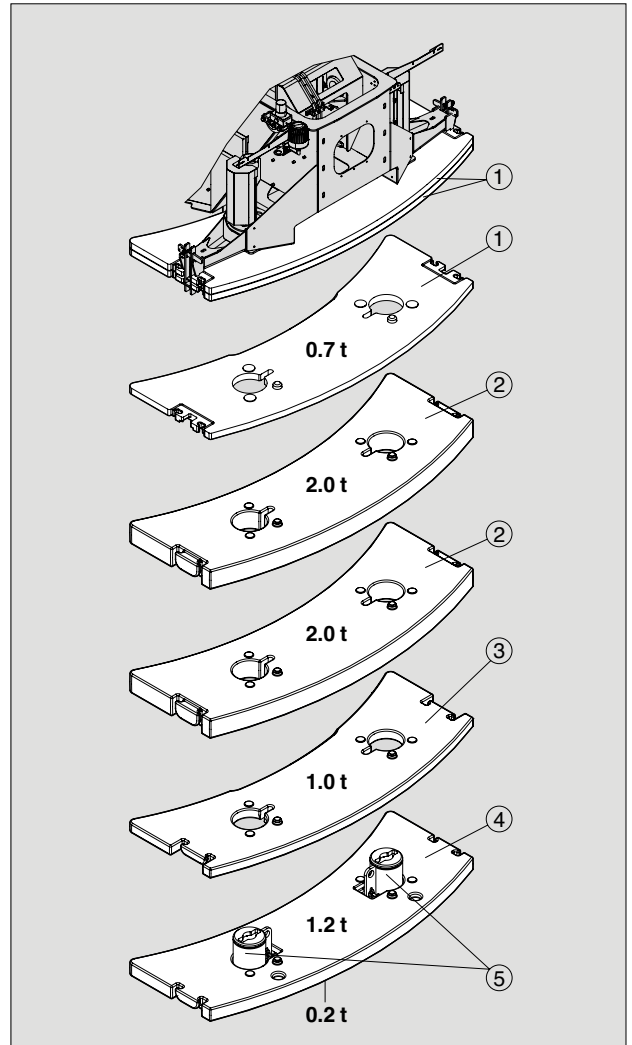
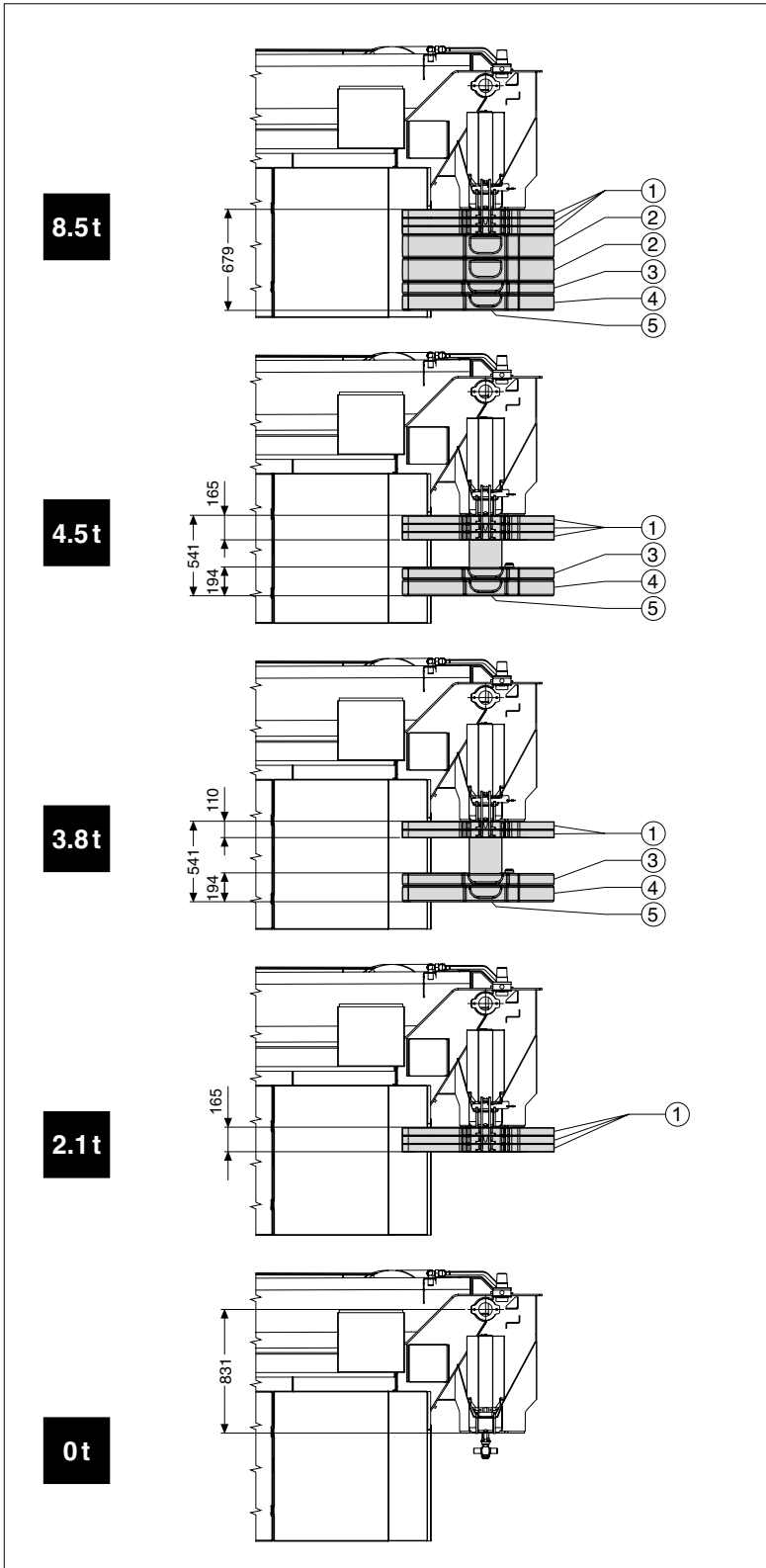



Gegengewicht / Counterweight	1 x	1 x	1 x	2 x	1 x	1 x	1 x
	①	②	③	④	⑤	⑥	⑦
(t)	0.7	0.7	0.7	2.0	1.0	1.2	0.2

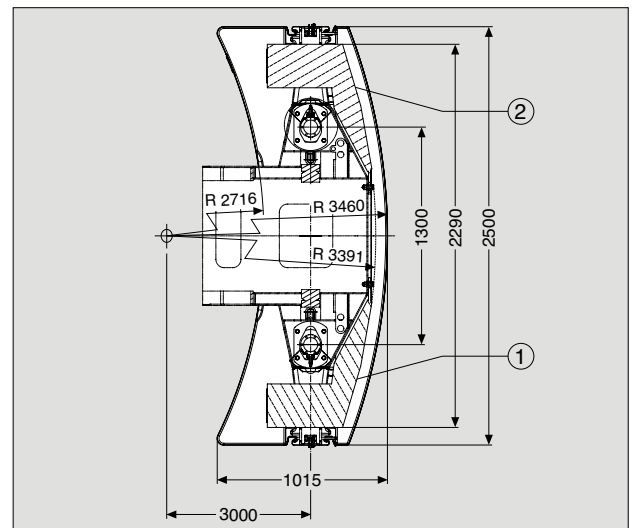
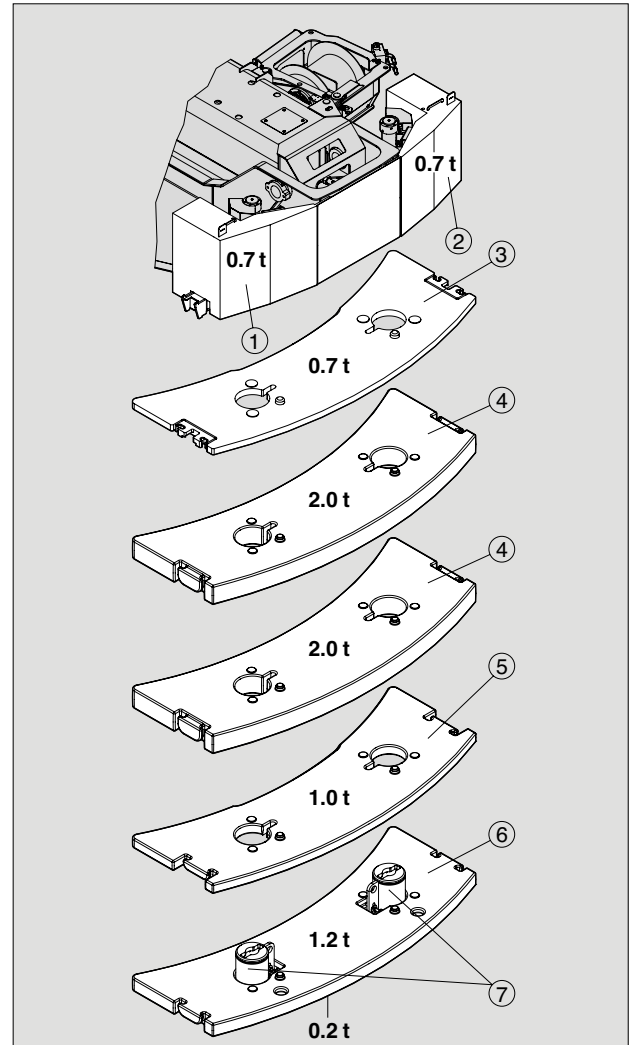
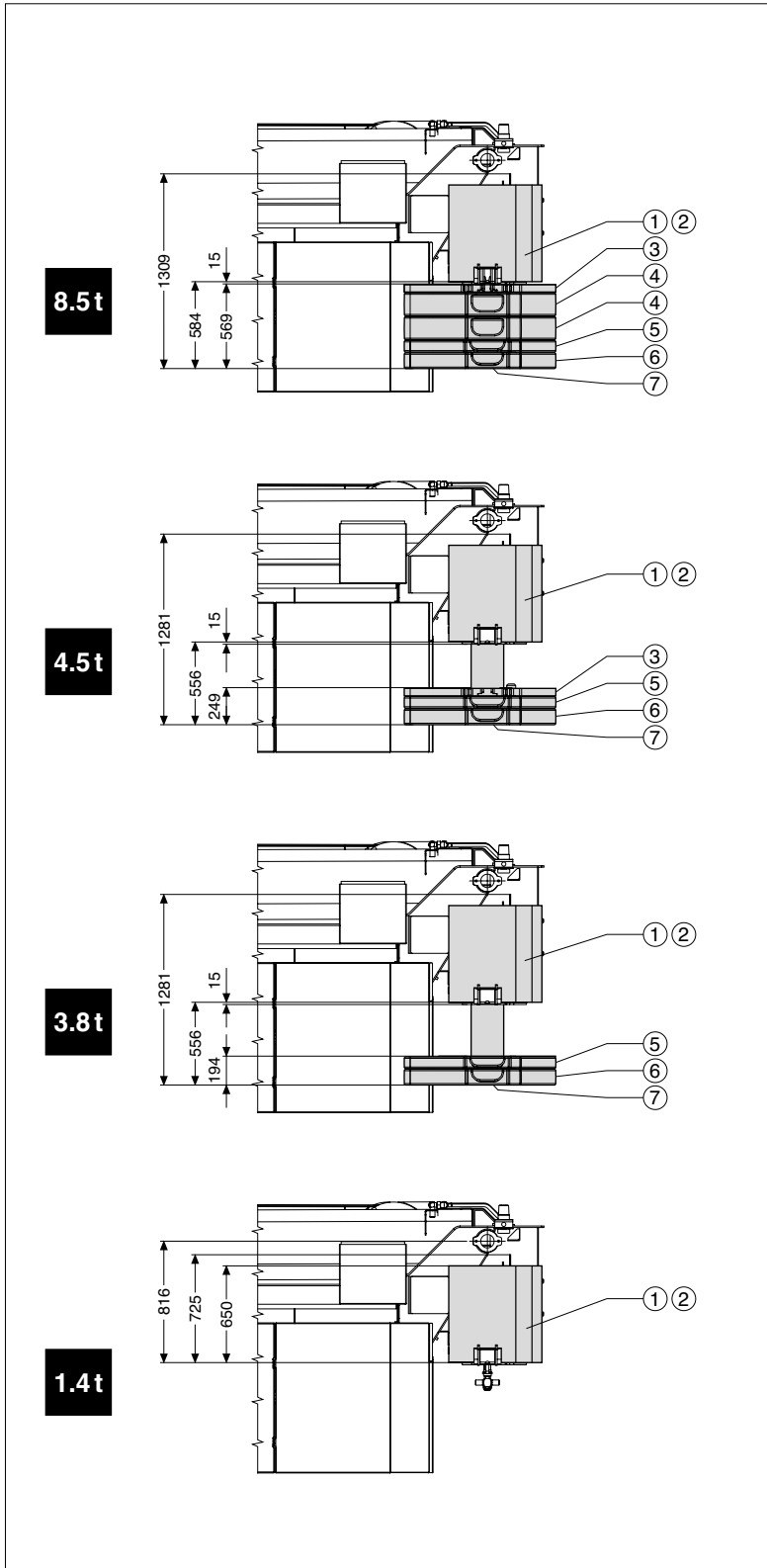

Ausrüstung

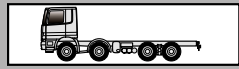

Fahrgestell 3 oder 4-achsiges handelsübliches Fahrgestell der Hersteller Mercedes-Benz, MAN, DAF, Iveco, Volvo und Scania.

Andere Fahrgestelle auf Anfrage.

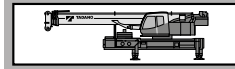

Hauptrahmen Verwindungs- und biegesteife Stahlkonstruktion aus hochfestem Feinkornstahl in Kastenbauweise mit Zwischenrahmen zur Befestigung am Trägerfahrzeug.

Abstützung Hydraulische, teleskopierbare 4-Punkt-Abstützung vorne schwenkbar, Bedienungsmöglichkeiten an beiden Seiten des Fahrgestelles und in der Oberwagenkabine. Abstützbasis 6,31 m x 6,49 m und 4,90 m x 6,20 m.

Oberwagenrahmen Verwindungsteife Schweißkonstruktion mit einer außenverzahnten, einreihigen Kugeldrehverbindung, um 360° unbegrenzt drehbar.

Motor Mercedes-Benz 4-Zylinder-Dieselmotor OM 904 LA, wassergekühlt. Drehzahl über Fußpedal stufenlos regelbar, Leistung 88 kW (118 PS) bei 2000 min⁻¹. Drehmoment 470 Nm (48 kpm) bei 1200 min⁻¹. Motorleistung nach DIN 6270B / DIN 6271. Kraftstoffbehälter 150 l.

Hydraulik System Diesel-hydraulisch mit 3-Kreishydraulik, 1 leistungsgeregelte Axialkolbendoppelpumpe (hydraulisch verstellbar) und 1 Zahnrad-Doppelpumpe, Ölkühler.

Steuerung Zwei 4-fach Kreuzsteuerhebel mit hydraulischer Vorsteuerung für gleichzeitige, voneinander unabhängige Kranbewegungen.

Teleskopausleger Vierteiliger Teleskopausleger aus hochfestem Feinkornstahl, bestehend aus einem Grundausleger und 3 Teleskopteilen, einstufigem Teleskopzylinder und Seilen, hydraulisch unter Teillast teleskopierbar. 10,45m - 35,20 m lang. Rollenkopf mit 5 Seilrollen.

Wippwerk Differentialzylinder mit angebautem Senkbremssperrventil.

Hubwerk Axialkolben-Motor, Hubwerkstrommel mit eingebautem Planetengetriebe und federbelasteter Hydro-Lamellenbremse mit integriertem Freilauf beim Heben. Hubseil mit 'Super-Stop' Einrichtung.

Drehwerk Axialkolben-Motor, dreistufiges Planetengetriebe mit fußbetätigter Betriebsbremse und Feststellung. Drehgeschwindigkeit stufenlos von 0 - 2 min⁻¹.

Gegengewicht Standard 4,5 t teilbar. Die Bedienung erfolgt aus der Oberwagenkabine.

Oberwagenkabine Großräumige Krankabine in Stahl-Kunststoffausführung mit Sicherheitsverglasung mit getönten Scheiben, verstellbarem hydraulisch gedämpftem Fahrersitz, motorunabhängige Wasserheizung mit Motorvorwärmung, Klimaanlage, Kontroll- und Bedienungselemente für Kranbetrieb, Betätigung der Abstützzylinder vom Oberwagen.

Elektrische Anlage 24 V Gleichstrom, 2 Batterien.

Sicherheitseinrichtungen Lastmomentbegrenzung (LMB), Hubendschalter, Windenendschalter, Seilwindendrehmelder, Sicherheitsventile gegen Rohr- und Schlauchbrüche. Sperrventile an Hydraulik-Zylindern.

Zusatzausrüstung (gegen Mehrpreis) Auslegerverlängerung 9 m, abwinkelbar 0°, 20° und 40°, Zusatzgegengewicht 4 t, 4 t Hakengeschirr, verschiedene Unterflaschen, Drehbereichsbegrenzung, Sonderlackierung und Beschriftung.

Weitere Zusatzausrüstung auf Anfrage.

Anmerkungen zu den Traglasttabellen

Die Tragfähigkeiten im Festigkeitsbereich basieren auf DIN 15018 Teil 3 / F.E.M. / EN 13000.

Die Tragfähigkeiten im Standsicherheitsbereich entsprechen DIN 15019 Teil 2 / ISO 4305 / EN 13000.

Die zulässige Windgeschwindigkeit beträgt maximal 15 m/sec.

Die Tragfähigkeiten sind in metrischen Tonnen angegeben.

Das Gewicht des Lasthakens bzw. der Hakenflasche und weiterer Anschlagmittel ist von der Tragfähigkeit abzuziehen.

Die Tragfähigkeiten für den Teleskopausleger gelten nur bei demontierter Auslegerverlängerung.

Die Ausladung ist der horizontale Abstand von Mitte Drehkranz bis Mitte freihängender, nicht schwingender Last.

Tragfähigkeitsänderungen vorbehalten.

Obige Angaben dienen nur zur Information. Die Bedienungsanleitungen müssen zu Rate gezogen werden, bevor die Maschine in Betrieb genommen wird. Alle hier gemachten Angaben beziehen sich auf die Standard-Ausführung. Jegliche Ausrüstungsveränderungen können die angegebenen Werte beeinflussen.

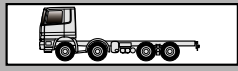

Chassis 3 or 4 axle Mercedes-Benz, MAN, DAF, Iveco, Volvo or Scania chassis.

Other chassis on request.

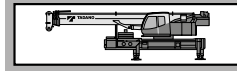

Main frame Torsion-resistant, steel construction made from high strength, fine-grained steel. Specially designed for the type of chassis selected.

Outriggers Hydraulically extendable 4 point outriggers front slewable with controls on both sides of carrier and in superstructure cab.
Outrigger base 6.31 m x 6.49 m and 4.90 m x 6.20 m.

Frame Torsion-resistant all-welded structure with a single-row ball slewing ring with external gearing for 360° continuous rotation.

Superstructure engine Mercedes-Benz 4 cylinder model OM 904 LA, water cooled, diesel engine.
Engine speed infinitely controlled via pedal.
Rated at 88 kW (118 HP) at 2000 min⁻¹. Torque 470 Nm (48 kpm) at 1200 min⁻¹. Engine rating according to DIN 6270B / DIN 6271. Fuel tank 150 l.

Hydraulic system Three circuit diesel hydraulic system with 1 power controlled axial piston double pump (hydraulically adjustable) and 1 double gear pump, oil cooler.

Controls Hydraulic, 2 joy-stick levers for simultaneous and independent operation of 4 crane motions.

Telescopic boom 4 sections, made of high tensile, fine-grained steel, consisting of 1 base section and 3 telescoping sections, single telescopic cylinder and ropes.
All telescope sections extendable under partial load.
10.45 m to 35.20 m long. Boom head with 5 sheaves.

Derricking system 1 double acting hydraulic cylinder with integral brake and holding valve.

Main winch Axial piston motor, winch drum with integrated planetary reduction and hydraulically controlled spring-loaded multiple disc brake and integrated free rotation (no sagging of load when hoisting).
Hoist cable with 'Super-Stop' easy reeving system.

Slewing system Axial piston motor with three-stage planetary reduction with a foot actuated service and a parking brake.
Speed infinitely variable 0 - 2 min⁻¹.

Counterweight Standard 4.5 t divisible, assembled and disassembled by hydraulic cylinders controlled from superstructure cab.

Superstructure cab Spacious panoramic cab of composite structure with safety (tinted) glass windows with hydraulically cushioned adjustable seat, engine independent water heater with engine pre-heat, air conditioning, complete controls and instrumentation for crane operation, outrigger cylinders controlled from superstructure cab.

Electrical system 24 volt DC system, 2 batteries.

Safety devices Load moment device (LMD), hoist limit switch, lower limit switch, drum turn indicator, safety valves against pipe and hose rupture. Holding valves on hydraulic cylinders.

Optional Equipment (at extra charge)
Boom extension 9 m long, offsets 0°, 20° and 40°, additional counterweight 4 t, 4 t swivel hook, selection of hook blocks, slewing area limitation, special painting and lettering.
Further optional equipment available upon request.

Remarks concerning the load charts

The lifting capacities in the structural area are based on DIN 15018 part 3 / F.E.M. / EN 13000.

The lifting capacities in the stability area are based on DIN 15019 part 2 / ISO 4305 / EN 13000.

The maximum permissible wind speed for crane operation is 15 m/sec.

The lifting capacities are shown in metric tons.

The weight of load handling devices such as hook blocks, slings, etc., must be considered as part of the load and must be deducted from the lifting capacities.











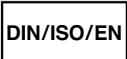

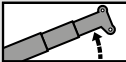
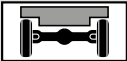
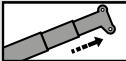
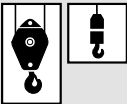
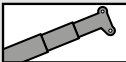

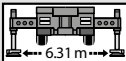

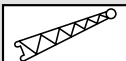

The lifting capacities for the telescopic boom apply to a crane with no boom extensions being stowed or mounted on the crane.

The working radius is the horizontal distance from the centre of rotation to the centre of the freely suspended non-oscillating load.

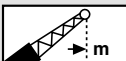
The lifting capacities are subject to change without prior notice.

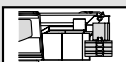
The above remarks are for basic information only and the operator's manual must be consulted before operating this crane. All data and performances refer to the standard crane. The addition of optional and other equipment may affect the performance of the crane.

Symbolerklärung Symbols

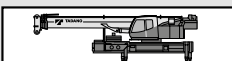
	Siehe Seite 24 As on Page 25		Achsen / Anzahl Axles / Number
	Räder / Größe Tyres / Size		Wippwerk Derricking system
	Achslast Axle load		Teleskopieren Boom telescoping
	Unterflasche / Hakengeschirr Hook block / Swivel hook		Teleskopausleger Telescopic boom
	Geschwindigkeiten Unterwagen Carrier speeds		Abstützung Outriggers
	Getriebe / Gang Transmission / Gear		Gegengewicht Counterweight
	Steigfähigkeit Gradeability		Ausladung Radius
	Gelände Off road		Auslegerverlängerung Boom extension
	Straße On road		Ausladung Radius
	Geschwindigkeiten Oberwagen Superstructure speeds		Gegengewichtvarianten Counterweight versions
	Hubwerk Main winch		Unterwagen Carrier
	Drehwerk Slewing system		Oberwagen Superstructure



A large grid area for taking notes, consisting of a light gray background with a white grid pattern.



TADANO FAUN GmbH

Faunberg 2, 91207 Lauf a. d. Pegnitz, Germany
Phone: +49-9123-185-0 Fax: +49-9123-3085
<http://www.tadanofaun.de> E-mail: info@tadanofaun.de

TADANO LTD. (International Division)

4-12, Kamezawa 2-chome, Sumida-ku Tokyo 130-0014, Japan
Phone: 81-3-3621-7750 Fax: 81-3-3621-7785
<http://www.tadano-global.com> E-mail: tdnihq@tadano.co.jp