

# GTC-400EX

40t Telescopic Boom Crawler Crane



 TADANO

**MANTIS**  
CRANES

SPECIFICATIONS & LOAD CHARTS



---

# MANTIS<sup>®</sup>

## CRANES

---

Tadano Mantis Corporation builds on the long tradition of the Mantis telescopic boom crawler crane, and sets the global standard with the dependability, versatility and performance expected of a market leader. Tadano Mantis cranes are built like no other. At their hearts are massive steel fabrications, over-sized to handle the toughest jobs, year-in and year-out. Powerful state-of-the-art hydraulics coupled with diesel engines available in a choice of sizes match perfectly to meet the most rigorous of project demands. Tadano Mantis Corporation remains one of the few crane makers prepared and equipped to work with contractors and project engineers to develop customized lifting solutions that meet the most unusual of project challenges. Thanks to the versatile combination of heavy duty telescopic booms, hydraulically extendable crawlers, and extremely compact dimensions, Mantis cranes can often get closer to a job than bulkier, fixed length lattice boom crawler cranes or rubber-tired cranes that need outriggers to work effectively.



# FEATURES

## NO OTHER CRANE COMBINES SO MANY VALUABLE FEATURES:

- Pick-and-carry the full crane load chart through 360°.
- Lift and walk...even with tracks retracted.
- Climb steeper grades, thanks to minimized counterweight and low center of gravity.
- Pull through deep mud without bogging down.
- Telescope or lift the boom with a full load on the hook.
- Save time and money on the job due to low clearance height, retract on-the-fly tracks and telescopic boom.
- Independent hydrostatic track drives allow pivot turns and counter rotation.
- Hydraulic tool circuit option powers wide choice of Mantis-approved tools.
- New luxury cab with state-of-the-art operator aids.
- Saves time and money on deployment and shipping with less haul vehicles, less time wasted on boom erection and fewer personnel on the erection crew.



Large access doors, spacious machinery compartments simplify preventative maintenance and service of the crane.



Conveniently positioned cameras display the winch as well as the blind area directly behind the crane. Full color video display in operator cab is standard equipment.



Spacious cab, adjustable seat, and conveniently located controls are common in all Tadano Mantis Cranes.



State-of-the-art, user friendly rated capacity limiter provides continuous feedback of crane lift and position data.

# ON THE JOB

The Tadano Mantis GTC-400EX combines rugged dependability with increased capacity and reach. Based upon performance-proven components and fabrications, the GTC-400EX is assured of the same bullet-proof reputation of its peers. Rated at 40t lifting capacity at 3m radius, the Tadano Mantis GTC-400EX is the envy of its imitators.

Like all Mantis cranes, the GTC-400EX is purpose-designed from the ground-up, not an assortment of pieces borrowed from other products.

For its size and power, the GTC-400EX has an extraordinarily low center of gravity with a minimum overhead clearance height of just 3.05m. And like all Tadano Mantis cranes, the GTC-400EX doesn't depend upon massive counterweighting for its strength – for big counterweights are a liability when climbing grades!

The GTC-400EX can walk with full boom and jib deployed, delivering an impressive 48.5m maximum tip height. Such is the stability of the GTC-400EX that it can operate with the fully telescoped main boom laid out completely horizontal!



The ability to telescope the boom under full load simplifies the handling and placement of heavy concrete poles.

## KEY FEATURES INCLUDE:

- 40t pick-and-carry capacity at 3m radius through 360°
- Sequence-synchronized four-section full power boom of 32m length
- Lattice boom extensions and offsettable jibs for up to 48,5m tip height
- 168kW diesel engine standard
- Low ground bearing pressure of 0,47 kg/cm<sup>2</sup> minimum
- Auger options with optional hydraulic tool circuit
- Fast two-speed independent hydrostatic track drive to 2,5 km/hr
- Full boom telescoping and boom lift under full hook load.
- 3,35-3,66m minimum travel width according to tracks selected.
- Extraordinarily low 3,05m overhead clearance height.
- Deluxe operators cab and standard LMI and Anti-Two-Block devices
- 42,6t shipping weight fully equipped – hauls as a single, ready-to-work load
- Steep 68% gradeability
- Hydraulic on-the-fly track frame retraction and extension
- Powerful 7,9t planetary main winch with full load single line speeds to 69,5 mpm or 149 mpm no-load speed
- High 330mm ground clearance helps avoid damage and snagging



Low ground pressure, fast travel speed, easy boom deployment, and an auger onboard make the crane an ideal machine for use in many applications. Above Picture shows installation of optional complete auger kit.



Low center of gravity and 68% gradeability allow the crane to easily traverse many conditions and quickly reach the jobsite.



Pick and carry poles, drill foundation holes, and string wires with the same machine.



With a transport weight of just 42.6t, the GTC-400EX can be transported on a single trailer and be ready to work within minutes of arrival at a jobsite.

# DIMENSIONS

# GTC-400EX

40t Telescopic Boom Crawler Crane

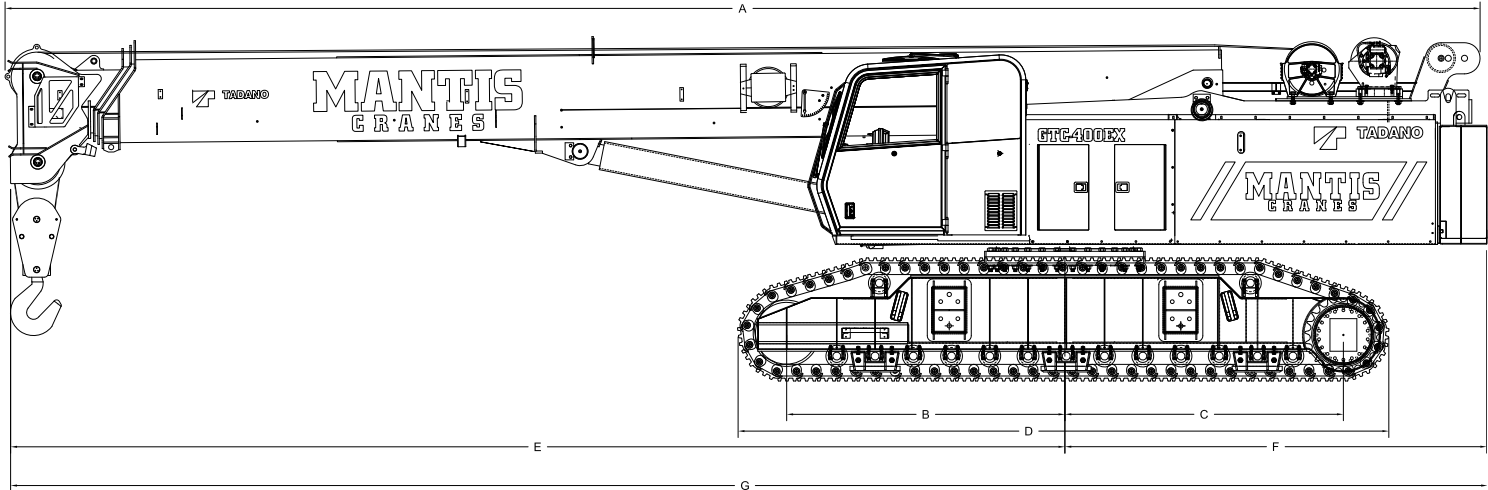

## PRINCIPAL DIMENSIONS

A	Length (Counterweight Removed)	13,02 m
B	CL Front Track Drive to CL Rotation	2,46 m
C	CL Rear Track Drive to CL Rotation	2,46 m
D	Track Length	5,79 m
E	Boom Length to CL Rotation	9,40 m
F	Tailswing	3,91 m
G	Overall Length	13,29 m
H	Ground to Top of Engine Cover	2,54 m
I	Track Height	1 067 mm
J	Ground Clearance	330 mm
K	Ground to Bottom of Cab	1219 mm
L	Maximum Overall Height	3,05 m
M	Track Width	900 mm
N	Overall Width (Tracks Retracted)	3,66 m
O	Overall Working Width	5,59 m

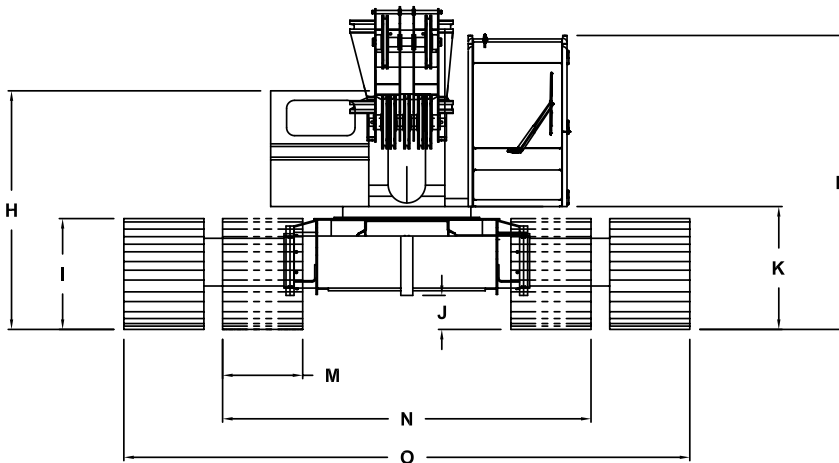

## WIDTHS, WEIGHTS, AND GROUND PRESSURES\*

Shoe Width	Overall Width		Area	Ground Pressure	Working Weight
	Retracted	Extended			
610 mm	3.35 m	5.22 m	6.04 m <sup>2</sup>	0.68 kg/cm <sup>2</sup>	40,800 kg
760 mm	3.51 m	5.39 m	7.55 m <sup>2</sup>	0.51 kg/cm <sup>2</sup>	41,700 kg
900 mm	3.66 m	5.59 m	9.06 m <sup>2</sup>	0.47 kg/cm <sup>2</sup>	42,590 kg

\* Crane equipped with: 32m boom, extension, jib 40t hook block, 11t headache ball

### CRANE SPECIFICATION

#### Boom

4-section full power synchronized telescoping boom, Synchronized telescoping system consists of two double acting hydraulic cylinders with load holding valves and extension and retraction cables,

**Telescoping System:** Two double acting hydraulic cylinders with load holding valves and extension and retraction cables

**Retracted Length:** 10,4m

**Extended Length:** 32,0m

**Boom Extension Time:** 91s

**Maximum Lifting Height:** 32,3m

**Elevating System:** Double acting hydraulic cylinder with load holding valves

**Elevating Angles:** -1° to 78°

**Boom Elevating Time:** 44s

**Boom Head:** Six, 483 mm diameter cast nylon sheaves on heavy-duty roller bearings

**Auxiliary Boom Head:** Quick reeve, single 483 mm diameter high-strength, cast nylon sheave mounted on a heavy-duty roller bearing

**Hook Block:** 40t hook block, four 457 mm diameter sheaves mounted on heavy-duty roller bearings with swivel hook and safety latch.

**Headache Ball:** 11t ball includes a swivel hook with a safety latch.

#### Load Moment Indicator & Anti-Two Block

- Standard Rated Capacity Limiter and Anti-Two Block system
- Control function shutdown
- Audio and visual warnings
- LCD screen provides a continuous display of working boom length, boom angle, working load radius, tip height, parts-of-line (operator set), machine track configuration, relative load moment, maximum permissible load and actual load,
- Anti-two block weight allows quick reeving of hook blocks,

### SUPERSTRUCTURE

#### Frame

The frame is an all-steel, welded structure, precision machined to accept attachment of the boom and swing components.

#### Operator's Cab

- Fully-enclosed, air conditioned all-steel modular cab with lockable swinging door, acoustical lining, anti-slip floor and tinted safety glass.
- Sliding windows located in the cab door and cab boom side.
- Vent window in the rear of the cab.
- Grab bars and steps are located for easy access to the cab.
- Rear view cameras are appropriately located as are three remote control work lights.
- 2-speed windshield wiper, top glass wiper
- Defroster, heater, circulating fan
- Six-way adjustable fabric seat with headrest, seat belt
- Dome light
- Dry-chemical fire extinguisher.
- Dash instrumentation: tachometer, voltmeter, oil pressure gauge, temperature gauge, hour meter and fuel gauge. Indicators are provided for crane level, load moment, drum rotation, air filter restriction, hydraulic oil temperature and filter restriction, engine oil pressure and temperature.
- Seat and armrest termination switches immediately disable all hydraulic functions as the operator rises from the seat or lifts the left hand armrest.
- Two-way hydraulic armrest mounted joysticks control swing, auxiliary winch, main winch and boom hoist. Four two-way hydraulic foot pedals control the travel, boom extend, and swing service brake functions.
- Adjustable hand and foot throttles

#### Counterweight

The 6804 kg single piece counterweight can be removed and installed via a pendant attached to the boom.

#### Swing

Gear motor driving a planetary gear reducer with a shaft mounted pinion, external gear shear ball slew bearing bolted to the superstructure and the carbody allows the superstructure to rotate 360°

#### Free Swing system

**Swing Speed:** Up to 3 rpm

**Swing Parking brake:** Spring applied failsafe brake with hydraulic release that is controlled from the operators cab

**Swing Service Brake:** Hydraulically applied controlled through foot actuated pedal

**House lock system:** 2-position manually pinned

**Lubrication system:** Cab mounted grease applicator

#### Fuel System

**Capacity:** 303 liter

**Filtration:** Inline fuel/water separator and engine mounted fuel filter.

#### Hydraulic System

**Hydraulic Pumps:** Two high pressure, variable axial piston pumps with load sense and torque limiting control for crane functions.

**Directional Valves:** Multiple pressure and flow compensated valves with integrated relief valves controlled by hydraulic pilot signals.

**Pump output:** 605 liter/min @ 2100 RPM engine speed. 330 bar maximum pressure

**Reservoir:** 1,136 liter capacity, spin-on filler/breather, sight gauge, cleanout, and sump drain.

**Filtration:** 5 micron, full flow tank mounted return filters with electrical clogging indicator; 5 micron pilot oil in-line pressure filter with electrical clogging indicator.

**Diagnostic Ports:** Provided for system, load sense, and pilot pressure.

### UNDERCARRIAGE

#### Carbody

The steel box type carbody is fabricated with square axles to accept the crawler side frames. The top surface is precision machined to receive the swing bearing.

#### Side Frames

Two welded steel side frames are paired with a track group. The side frames extend and retract hydraulically and are controlled from the cab.

**Track Rollers:** Two top and thirteen bottom sealed rollers on each track frame

**Idler:** Oil filled, self lubricating with spring type tensioner

**Track Shoes:** 900mm 3-bar semi grouser (standard)

760mm 3-bar semi grouser (optional)

610mm 3-bar semi grouser (optional)

760mm flat shoe (optional)

#### Travel

Each side frame contains a pilot controlled, two-speed track drive with hydraulic axial piston motor and parking brake. Travel system provides skid steering and counter rotation.

**Low travel speed:** 1,5 km/h

**High travel speed :** 2,5 km/h

**Gradeability (unladen):** 68%

### OPTIONAL EQUIPMENT

**Boom Extension:** Lattice type, swingaway, stores along boom base section and can be used with or without optional jib, One of two parts of line may be reeved,

**Length:** 9,10m

**Head:** Two, 483 mm diameter cast nylon sheaves on heavy-duty roller bearings

**Maximum Lifting Height:** 41,2m

**Boom Jib:** Lattice type, swingaway, stores along boom extension and can only be used with extension deployed,

**Length:** 6,10m

**Offset Angles:** 15° & 30°

**Maximum Lifting Height:** 47,0m

#### Auger Ready Package:

Includes hoses, fasteners and stowage bracket assembly mounted to the base section of the boom with a flow capability of 130 liter/min

#### Complete Auger Package:

Adds a two speed auger motor/gear box and one 1,52 m kelly bar to the Auger Ready Package.

**Tool Circuit:** Provides 23 liter/min and 45 liter/min at 176 bar through a 15,24 m twin hose reel with quick disconnect fittings to operate open center tools.

#### Free Fall Hoists:

All winches are available in controlled free fall configurations.

#### Crane Access Walkway:

Cab walkway and folding walkways along each side of the superstructure.

<sup>1</sup>Load moment indicating and anti-two block systems are operator aids and must never be used in lieu of job site lift planning calculations by the operator which must take into account ground conditions, weather and all other environmental factors prevailing at the time of the lift. Prices and specifications are subject to change at any time without prior notice and are for factory installation at time of original manufacture. F.O.B Plant; Richlands, VA 24641. Illustrations and photographs may show optional equipment. Supersedes all previous issues. Please see [www.mantiscranes.com](http://www.mantiscranes.com) for most current information.



### MAIN WINCH

Planetary geared two-speed winch includes a bent axis, variable displacement hydraulic motor and a multi-disc internal brake.  
Wire Rope: 183 m 16 mm 6 x 37 EIPS, IWRC, RRL. Line pulls are not based on wire rope strength. Drum rotation indicator is standard.

Rope Layer	Maximum Line Pull	Full Load Line Speed	Pitch Diameter	Layer	Total
1	77,8 kN	54,6 m/min	288,9 mm	23,2 m	23,2 m
2	69,8 kN	58,8 m/min	316,3 mm	25,3 m	48,5 m
3	63,6 kN	61,6 m/min	343,6 mm	27,7 m	76,3 m
4	58,3 kN	64,0 m/min	370,9 mm	29,9 m	106,1 m
5	53,8 kN	68,6 m/min	398,3 mm	32,0 m	138,1 m

### AUXILIARY WINCH

Planetary geared single-speed winch includes a bent axis, variable displacement hydraulic motor and a multi-disc internal brake.  
Wire Rope: 107 m 16 mm 6 x 37 EIPS, IWRC, RRL. Line pulls are not based on wire rope strength. Drum rotation indicator is standard.

Rope Layer	Maximum Line Pull	Full Load Line Speed	Pitch Diameter	Layer	Total
1	53,4 kN	55,5 m/min	263,5 mm	19,8 m	19,8 m
2	47,6 kN	60,4 m/min	290,9 mm	20,1 m	38,4 m
3	43,6 kN	63,4 m/min	318,2 mm	22,6 m	60,7 m
4	40,0 kN	66,1 m/min	345,5 mm	24,7 m	85,6 m
5	36,9 kN	71,0 m/min	372,9 mm	27,1 m	112,8 m

### ENGINE

Cummins QSB6.7 (U.S. EPA Tier 3, CARB Tier 3, Euromot Stage IIIA)

Noise Emissions: Top 96.3 dBA (excludes noise from intake, exhaust, cooling system and driven components)

Type	6 Cylinder Water Cooled	Weight (Wet)	479 kg	Aspiration	Turbocharged & Aftercooled
Displacement	6,7 liter	Oil Capacity	16,3 liter	Air Filter	Dry Type
Bore	107 mm	Rated Power	179 kW @ 2200 rpm	Electrical System	12 volt
Stroke	124 mm	Peak Torque	938Nm @ 1500 rpm	Alternator	100 amp

### MACHINE WEIGHTS

STANDARD CRANE WITH 4 SECTION 32 m BOOM, 1 PIECE COUNTERWEIGHT & 900 mm TRACK SHOES	40,780 kg
Crane Less Counterweight and Track Frames	23,280 kg
Counterweight	6,800 kg
Track Frames, 2 pieces 5,350 kg each	10,700 kg
Auxiliary Nose Sheave	95 kg
11t Headache Ball	183 kg
40t Hook Block	544 kg
Auxiliary Winch with Standard Rope	311 kg

### OPTIONAL EQUIPMENT

9.1 m Lattice Extension	771 kg
6.1 m Jib (connects to head of Lattice Extension ONLY)	318 kg
Auger Ready Package	200 kg
Complete Auger Package	690 kg
1,5m Auger Kelly Bar	54 kg
1,8m Auger Kelly Bar	64 kg

\* Deduction from Standard Crane Weight

## 32M MAIN BOOM, 9.1M EXTENSION & 6.1M JIB

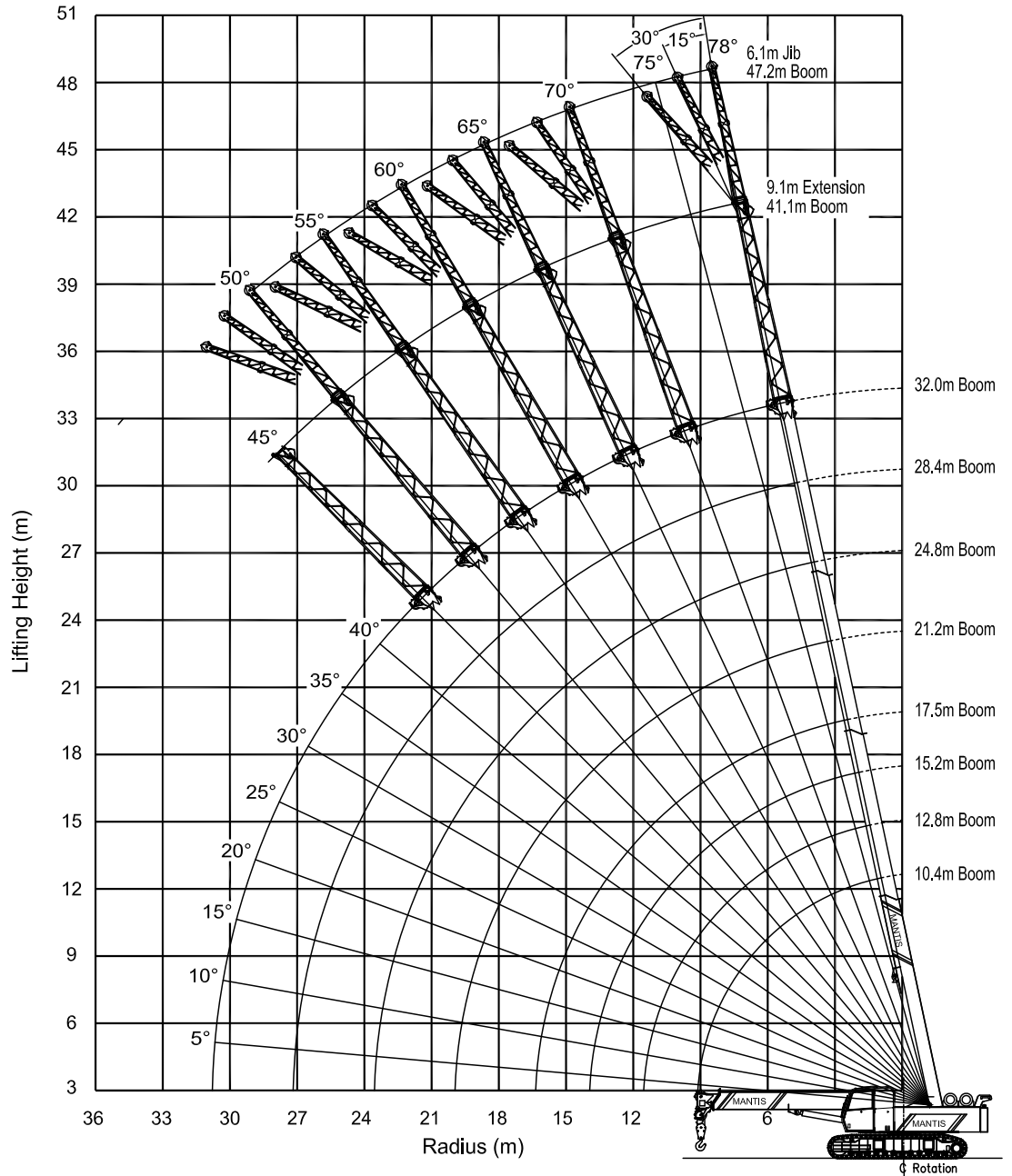
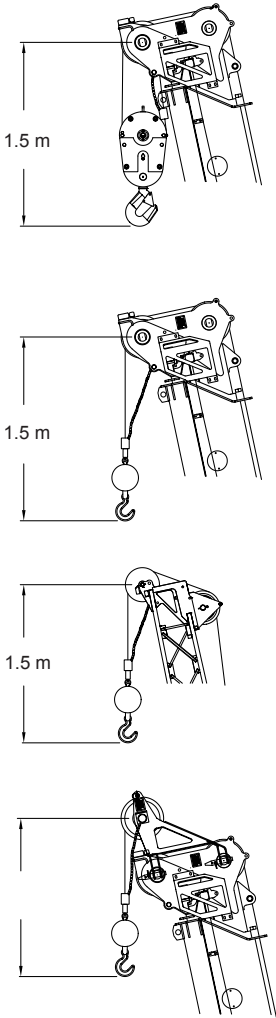

## LIFTING CAPACITIES

LOADS IN METRIC TON

MAIN BOOM with TRACKS FULLY EXTENDED									
RADIUS (m)	MAIN BOOM LENGTH								RADIUS (m)
	10,4	12,8	15,2	17,5	21,2	24,8	28,4	32,0	
3,0	40,8	36,3	31,8	27,6					3,0
3,5	39,2	35,6	29,7	25,6					3,5
4,0	35,3	33,0	27,8	23,8	21,3				4,0
4,5	30,6	29,5	26,1	22,1	20,5	17,5			4,5
5,0	27,2	26,6	24,3	20,8	19,3	16,9			5,0
6,0	21,0	20,8	20,5	18,3	16,8	14,7	13,4	12,4	6,0
7,0	17,3	17,2	17,0	16,0	15,0	13,0	12,2	11,2	7,0
8,0	14,2	14,0	13,8	13,6	13,1	11,6	10,9	9,9	8,0
9,0	11,7	11,5	11,3	11,0	11,0	10,5	9,8	8,8	9,0
10,0		9,5	9,3	8,9	9,2	9,2	8,8	7,9	10,0
12,0			6,2	5,9	6,6	6,9	7,0	6,5	12,0
14,0				4,3	4,9	5,2	5,4	5,4	14,0
16,0				3,4	3,9	4,1	4,4	4,5	16,0
18,0					3,0	3,2	3,4	3,5	18,0
20,0						2,5	2,7	2,8	20,0
22,0						2,0	2,1	2,2	22,0
24,0							1,6	1,7	24,0
26,0							1,0	1,2	26,0
28,0								0,8	28,0
30,0								0,6	30,0

NOTE: Capacities appearing above the bold line are based on structural strength; tipping should not be relied upon as a capacity limitation. Capacities appearing below the bold line are based on stability and do not exceed 75% of tipping.



THESE CHART VALUES ARE ONLY A GUIDE AND MUST NOT BE USED TO OPERATE THE CRANE. USE ONLY THE IN CAB LOAD CHARTS AND OPERATOR'S MANUAL FURNISHED WITH THE CRANE.



### CAUTION

## LIFTING CAPACITIES LOADS IN METRIC TON

MAIN BOOM with TRACKS FULLY EXTENDED									
RADIUS (m)	MAIN BOOM LENGTH								RADIUS (m)
	10,4	12,8	15,2	17,5	21,2	24,8	28,4	32,0	
3,0	40,8	36,3	31,8	27,6					3,0
3,5	35,6	33,6	29,7	25,6					3,5
4,0	30,0	29,2	26,6	23,7	21,3				4,0
4,5	24,5	24,1	23,2	22,0	20,5	17,5			4,5
5,0	20,9	20,5	19,8	18,8	18,0	16,2			5,0
6,0	14,4	13,6	12,9	11,9	12,2	12,4	13,4	12,4	6,0
7,0	11,0	10,5	10,1	9,6	10,0	10,3	11,1	10,8	7,0
8,0	8,5	8,3	8,1	8,0	8,3	8,6	8,8	9,0	8,0
9,0	6,7	6,6	6,6	6,5	6,8	7,1	7,3	7,5	9,0
10,0		5,6	5,4	5,3	5,5	5,7	5,9	6,2	10,0
12,0			36,0	3,4	3,6	3,9	4,2	4,5	12,0
14,0				2,4	2,7	2,9	3,1	3,2	14,0
16,0				1,8	1,8	2,0	2,1	2,2	16,0
18,0					1,0	1,1	1,3	1,4	18,0
20,0						NR	NR	NR	20,0
22,0						NR	NR	NR	22,0
24,0							NR	NR	24,0
26,0							NR	NR	26,0
28,0								NR	28,0
30,0								NR	30,0

NOTE: Capacities appearing above the bold line are based on structural strength; tipping should not be relied upon as a capacity limitation. Capacities appearing below the bold line are based on stability and do not exceed 75% of tipping.



## LIFTING CAPACITIES LOADS IN METRIC TON

MAIN BOOM with TRACKS RETRACTED									
RADIUS (m)	MAIN BOOM LENGTH								RADIUS (m)
	10,4	12,8	15,2	17,5	21,2	24,8	28,4	32,0	
3,0	34,0	36,2	31,8	27,6					3,0
3,5	27,1	28,2	26,8	25,6					3,5
4,0	22,8	23,1	22,7	22,3	20,5				4,0
4,5	19,9	19,8	19,2	18,5	18,6	18,5			4,5
5,0	17,6	17,3	16,7	16,0	16,4	17,0			5,0
6,0	13,1	12,6	12,0	11,6	12,1	12,7	12,7	13,2	6,0
7,0	10,2	9,9	9,6	9,4	9,7	10,1	10,6	11,0	7,0
8,0	7,9	7,8	7,7	7,6	7,8	8,0	8,3	8,7	8,0
9,0	6,2	6,1	6,1	6,0	6,1	6,3	6,5	6,7	9,0
10,0		4,9	4,8	4,7	5,0	5,3	5,5	5,8	10,0
12,0			3,0	2,9	3,3	3,6	4,0	4,4	12,0
14,0				2,2	2,5	2,7	3,0	3,3	14,0
16,0				1,6	1,8	2,0	2,2	2,3	16,0
18,0					1,1	1,3	1,4	1,6	18,0
20,0						0,8	0,9	1,0	20,0
22,0						0,5	0,5	0,7	22,0

NOTE: Capacities appearing above the bold line are based on structural strength; tipping should not be relied upon as a capacity limitation. Capacities appearing below the bold line are based on stability and do not exceed 75% of tipping.

### LIFTING CAPACITIES LOADS IN METRIC TON

9,1m EXTENSION & 6,1m JIB						
360°		1°		6,8t		
9,1m EXTENSION			6,1m JIB			
BOOM ANGLE	Total Boom Length		Jib Offset Angles			BOOM ANGLE
	16,1-28m	>32m	0°	15°	30°	
78°	8,2	6,4	3,0	1,8	1,0	78°
75°	6,2	5,6	2,9	1,8	1,0	75°
72°	5,2	4,5	2,5	1,6	0,9	72°
70°	4,6	4,1	2,3	1,5	0,9	70°
68°	4,0	3,6	2,1	1,4	0,8	68°
65°	3,6	3,4	1,9	1,3	0,8	65°
62°	3,3	2,7	1,8	1,2	0,8	62°
60°	3,0	2,0	1,6	1,1	0,8	60°
58°	2,8	1,8	1,5	0,9	0,6	58°
55°	2,6	1,4	1,2	0,6	0,5	55°
52°	2,4	1,1	0,9	0,3	0,2	52°
50°	2,3	0,9	0,7	0,1	0,1	50°
48°	2,2	0,7				48°
45°	2,1	0,5				45°

**NEVER** use extension or jib without counterweight in place.

NOTE: Capacities appearing above the bold line are based on structural strength; tipping should not be relied upon as a capacity limitation. Capacities appearing below the bold line are based on stability and do not exceed 75% of tipping.

Weight Reductions for Load Handling Devices	
<b>Hookblocks</b>	
40,8 t - 4 Sheave	493 kg
10,9 t Overhaul Ball w/Swivel	180 kg
<b>Optional Load Handling Devices</b>	
9,1m Extension - Stowed*	160 kg
9,1m Extension - Erected*	910 kg
9,1m Ext, and 6,1m Jib - Stowed*	340 kg
9,1m Ext, and 6,1m Jib - Erected*	1590 kg
Auxiliary Nose Sheave*	90 kg
Auger Ready Package*	105 kg
Auger Package Complete - Stowed*	255 kg
Auger Package Complete - Erected*	545 kg

\*Reduction of main boom capacities

AUXILIARY BOOM NOSE SHEAVE										
10,4-32m		360°		1°		6,8t		1,4 km/h		
RADIUS (m)	MAIN BOOM LENGTH								RADIUS (m)	
	10,4	12,8	15,2	17,5	21,2	24,8	28,4	32,0		
3,0	5,0	5,0	5,0	5,0						3,0
3,5	5,0	5,0	5,0	5,0						3,5
4,0	5,0	5,0	5,0	5,0	5,0					4,0
4,5	5,0	5,0	5,0	5,0	5,0	5,0				4,5
5,0	5,0	5,0	5,0	5,0	5,0	5,0				5,0
6,0	5,0	5,0	5,0	5,0	5,0	5,0	5,0	5,0	5,0	6,0
7,0	5,0	5,0	5,0	5,0	5,0	5,0	5,0	5,0	5,0	7,0
8,0	5,0	5,0	5,0	5,0	5,0	5,0	5,0	5,0	5,0	8,0
9,0	5,0	5,0	5,0	5,0	5,0	5,0	5,0	5,0	5,0	9,0
10,0		5,0	5,0	5,0	5,0	5,0	5,0	5,0	5,0	10,0
12,0			5,0	5,0	5,0	5,0	5,0	5,0	5,0	12,0
14,0				4,3	4,8	4,9	4,9	5,0		14,0
16,0				3,4	3,9	4,1	4,4	4,5		16,0
18,0					3,0	3,2	3,4	3,5		18,0
20,0						2,3	2,5	2,6		20,0
22,0							2,0	2,1	2,2	22,0
24,0								1,6	1,7	24,0
26,0								1,0	1,2	26,0
28,0									0,8	28,0
30,0									0,6	30,0

NOTE: Capacities appearing above the bold line are based on structural strength; tipping should not be relied upon as a capacity limitation. Capacities appearing below the bold line are based on stability and do not exceed 75% of tipping.



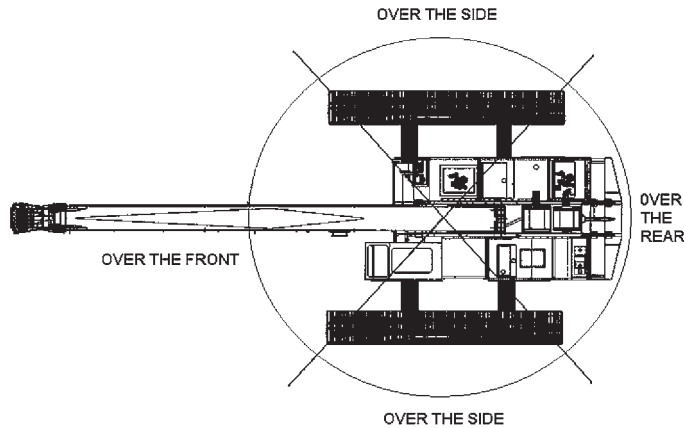

GTC-400EX				
WIRE ROPE LINE PULL CAPACITIES				
PARTS OF LINE	MAIN WINCH (kN)	AUX WINCH (kN)	PARTS OF LINE	MAIN WINCH (kN)
1	52	52	5	262
2	105	105	6	314
3	157	N/A	7	367
4	210	N/A	8	419

16mm diameter wire rope, 6 x 37 Class, EIP, IWRC

**PLEASE READ, UNDERSTAND, AND FOLLOW THE MANUALS FURNISHED WITH THE CRANE (OPERATOR'S AND SAFETY) AS WELL AS THE CAPACITY LIMITATIONS AND GENERAL CONDITIONS LISTED BELOW PRIOR TO OPERATION OF THE CRANE. FAILURE TO DO SO MAY RESULT IN AN ACCIDENT.**

### Capacity Limitations and General Conditions:

- This TADANO MANTIS CRANE as manufactured, meets the requirements of ANSI B30.5. Structure and stability have been tested in accordance with SAE J1063 and SAE J765, respectively. Modifications to the crane or use of optional equipment other than specified by the manufacturer can result in a reduction of capacity.
- The main boom and auxiliary boom head lifting capacities are determined by boom length and load radius. The extension and jib lifting capacities are determined by boom angle.
- Rated capacity loads given are maximum covered by the manufacturer's warranty and are based on a freely suspended load with NO allowance for factors such as out-of-level operation, supporting surface conditions, hazardous surroundings, experience of personnel, etc. The operator shall establish practical working loads based on prevailing operating conditions, such as, but not limited to the above.
- All rated capacity loads shown apply to original equipment as supplied by Tadano Mantis Corporation
- All rated capacity loads appearing above the bold line are based on structural strength; tipping should not be relied upon as a capacity limitation.
- All rated capacity loads appearing below the bold line are based on stability and do not exceed 75% of tipping.
- Deductions from rated capacities must be made for the weight of the hook block, headache ball, slings, spreader bar, and any other suspended equipment. See Lifting Capacity Deduction Chart for load handling devices supplied by Tadano Mantis Corporation
- A properly calibrated and maintained Load Moment Indicator (LMI) system will indicate boom mounted and other suspended equipment.
- When making lifts where capacities may be within a zone limited by structural strength, the operator shall determine that the weight of the load is known within plus or minus (+/-) ten percent (10%) before making lift.
- It is permissible to attempt to telescope boom with a load within the limits of rated capacities. However, boom telescope system hydraulic pressure, and/or boom lubrication may affect operation.
- Side pull on boom is extremely dangerous and must be avoided.
- DO NOT** exceed manufacturers maximum specified reeving.
- DO NOT** lift load or extend boom without proper configuration of crane per load chart selected.
- DO NOT** attempt to lift any load when wind speed exceeds 32,2 km/h.

Load moment indicating and anti-two block systems are operator aids and must never be used in lieu of job site lift planning calculations by the operator which must take into account ground conditions, weather and all other environmental factors prevailing at the time of the lift.

Prices and specifications are subject to change at any time without prior notice and are for factory installation at the time of original manufacture. F.O.B Plant; Richlands, VA 24641. Illustrations and photographs may show optional equipment. Supersedes all previous issues.

Please see [www.mantiscranes.com](http://www.mantiscranes.com) for most current information.

### Load Chart Symbol Key

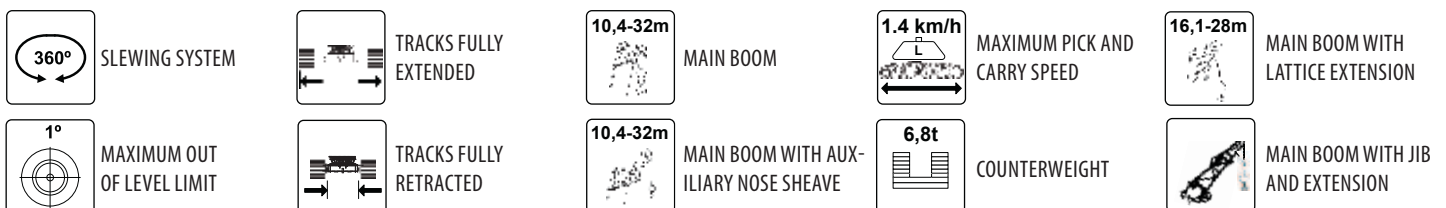

# TADANO MANTIS CORPORATION

1705 Columbia Avenue • Franklin, TN 37064 USA • Toll-Free: 1-800-272-3325 • Fax: 615-790-6803 • [mantiscranes.com](http://mantiscranes.com)

**TADANO Ltd., International Division**  
4-12, Kamezawa 2-chome,  
Sumida-Ku, Tokyo 130-0014, Japan  
Tel: +81 3 3621 7750  
Fax: +81 3 3621 7785  
E-mail: [tdnihq@tadano.co.jp](mailto:tdnihq@tadano.co.jp)  
[www.tadano.co.jp/indexe.html](http://www.tadano.co.jp/indexe.html)

## GTC-300EX 27t Telescopic Boom Crawler Crane

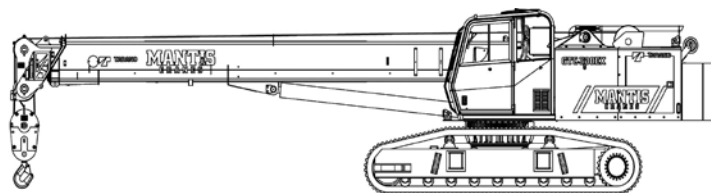

## GTC-400EX 40t Telescopic Boom Crawler Crane

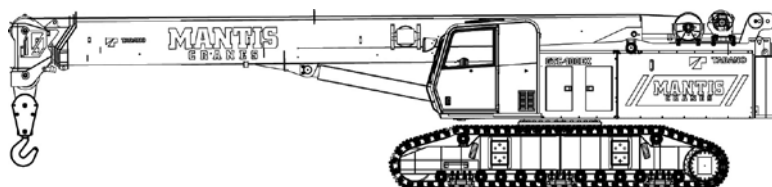

## GTC-700EX 70t Telescopic Boom Crawler Crane

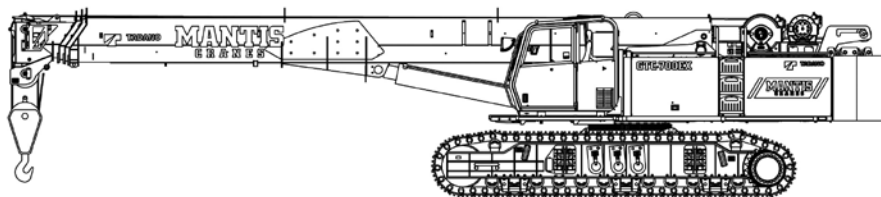

## GTC-1000EX 100t Telescopic Boom Crawler Crane

