

A4 FEM1.001

**H** = Height under hook  
Altezza sotto gancio  
Hauteur sous crochet  
Altura bajo el gancho  
Высота под крюком

## TOWER CONFIGURATION - REACTIONS

CONFIGURAZIONE TORRE - REAZIONI / CONFIGURATION TOUR - RÉACTIONS / TORRE DE CONFIGURACIÓN - REACCIONES / КОНФИГУРАЦИЯ БАШНИ - РЕАКЦИИ

### ▣ 1,5 m L = 3,8 m - A

	H (m)	Z (t)	F1(kN)
7	-	-	-
6	-	-	-
5	5,9 m	42,4	86,5 652
4	5,9 m	36,5	68,8 537
3	5,9 m	30,6	57,0 480
2	5,9 m	24,7	51,1 412
+1	5,9 m	18,8	51,1 401

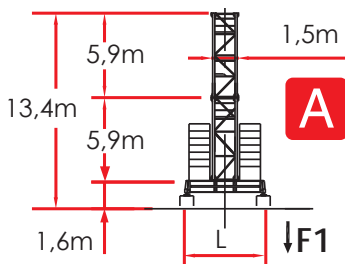

### ▣ 1,5 m L = 3,8 m - B

	H (m)	Z (t)	F1(kN)
7	-	-	-
6	-	-	-
5	5,9 m	42,3	82,6 688
4	5,9 m	36,4	64,9 495
3	5,9 m	30,5	53,1 443
2	5,9 m	24,6	53,1 405
+1	5,9 m	18,7	53,1 384

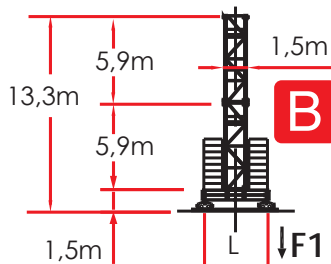

### ▣ 1,5 m L = 3,8 m - E

	H (m)	Z (t)	F1(kN)
7	-	-	-
6	-	-	-
5	5,9 m	41,8	82,6 675
4	5,9 m	35,9	64,9 498
3	5,9 m	30,0	53,1 441
2	5,9 m	24,1	53,1 403
+1	5,9 m	18,2	53,1 382

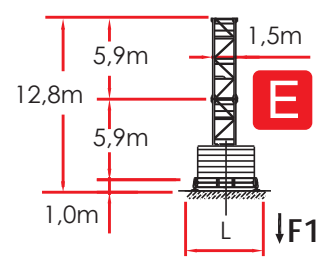

### ▣ 1,5 m L = 4,5 m - A

	H (m)	Z (t)	F1(kN)
7	-	-	-
6	4,4 m	46,8	80,6 673
5	5,9 m	42,4	62,9 537
4	5,9 m	36,5	51,1 457
3	5,9 m	30,6	45,2 421
2	5,9 m	24,7	39,3 382
+1	5,9 m	18,8	39,3 351

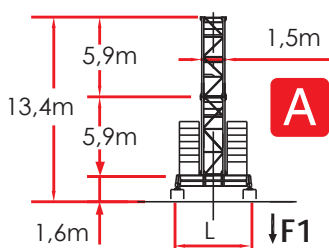

### ▣ 1,5 m L = 4,5 m - B

	H (m)	Z (t)	F1(kN)
7	-	-	-
6	4,4 m	46,7	76,7 641
5	5,9 m	42,3	59,0 517
4	5,9 m	36,4	47,2 447
3	5,9 m	30,5	41,3 400
2	5,9 m	24,6	35,4 366
+1	5,9 m	18,7	35,4 345

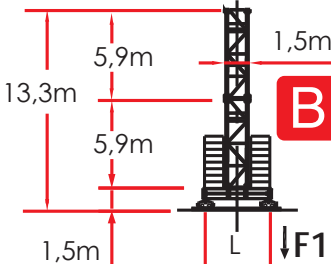

### ▣ 1,5 m L = 4,5 m - E

	H (m)	Z (t)	F1(kN)
7	-	-	-
6	4,4 m	46,2	76,7 673
5	5,9 m	41,8	59,0 516
4	5,9 m	35,9	47,2 439
3	5,9 m	30,0	41,3 396
2	5,9 m	24,1	35,4 354
+1	5,9 m	18,2	35,4 342

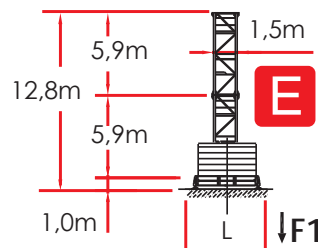

## TOWER CONFIGURATION - REACTIONS

CONFIGURAZIONE TORRE - REAZIONI / CONFIGURATION TOUR - RÉACTIONS / TORRE DE CONFIGURACIÓN - REACCIONES / КОНФИГУРАЦИЯ БАШНИ - РЕАКЦИИ

### 1,5 m - D

	H (m)	F2(kN)	F3(kN)
7	-	-	-
6	5,9 m	46,9	1328 1091
5	5,9 m	41,0	1013 793
4	5,9 m	35,1	743 538
3	5,9 m	29,2	724 501
2	5,9 m	23,3	660 446
+1	5,9 m	17,4	605 401

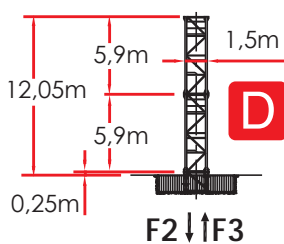

### 1,5 m Booster - D

	H (m)	F2(kN)	F3(kN)
7	-	55,7	1782 1553
6	5,9 m	-	-
5	5,9 m	-	-
4	5,9 m	-	-
3	5,9 m	-	-
2	5,9 m	-	-
+1	5,9 m	-	-

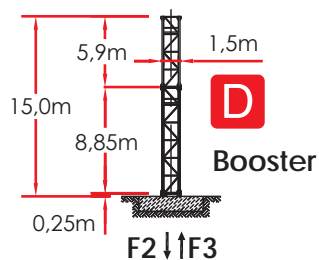

Comply with the specified ballast / Attenersi alla zavorra indicata / S'en tenir au lest indiqué / respetar el peso de lastre indicado / Соблюдать указанный балласт

### 1,7/1,5 m L = 4,5 m - A

	H (m)	Z (t)	F1(kN)
6	5,9 m	53,9	88,5 905
5	5,9 m	-	-
4	5,9 m	-	-
3	5,9 m	-	-
2	5,9 m	-	-
+1	5,9 m	-	-

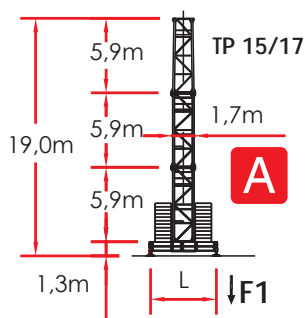

### 1,7/1,5 m L = 6,0 m - A

	H (m)	Z (t)	F1(kN)
6	5,9 m	53,9	59,0 668
5	5,9 m	-	-
4	5,9 m	-	-
3	5,9 m	-	-
2	5,9 m	-	-
+1	5,9 m	-	-

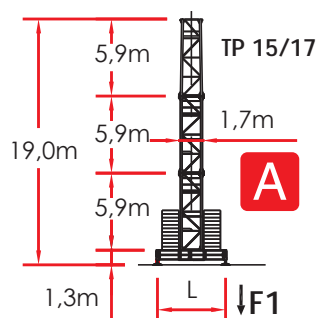

### 1,7/1,5 m - D

	H (m)	F2(kN)	F3(kN)
7	5,9 m	55,7	1684 1434
6	5,9 m	-	-
5	5,9 m	-	-
4	5,9 m	-	-
3	5,9 m	-	-
2	5,9 m	-	-
+1	5,9 m	-	-

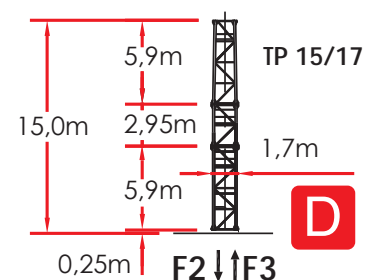

## LOAD DIAGRAMS 4.0 T

DIAGRAMMA DI PORTATA / DIAGRAMME DE CHARGE UTILE / CURVAS DE CARGA /  
 ДИАГРАММА ГРУЗОПОДЪЕМНОСТИ

### 4.000 Kg

JIB	24.0	30.0	36.0	42.0	48.0	50.0	54.0	60.0
1,6 ▶	17.5	30.0	33.6	33.2	33.0	33.0	28.5	24.4
12	4000	4000	4000	4000	4000	4000	4000	4000
14	4000	4000	4000	4000	4000	4000	4000	4000
16	4000	4000	4000	4000	4000	4000	4000	4000
18	4000	4000	4000	4000	4000	4000	4000	4000
20	4000	4000	4000	4000	4000	4000	4000	4000
22	4000	4000	4000	4000	4000	4000	4000	4000
24	<b>4000</b>	4000	4000	4000	4000	4000	4000	4000
26		4000	4000	4000	4000	4000	4000	3832
28		4000	4000	4000	4000	4000	4000	3571
30		<b>4000</b>	4000	4000	4000	4000	3873	3247
32			4000	4000	4000	4000	3597	3010
34			3979	3832	3767	3766	3353	2801
36			<b>3730</b>	3592	3530	3530	3138	2618
38				3327	3319	3318	2944	2453
40				3184	3129	3128	2772	2305
42				<b>3010</b>	2957	2957	2615	2171
44					2802	2801	2474	2050
46					2660	2559	2345	1939
48					<b>2530</b>	2529	2226	1838
50						<b>2410</b>	2117	1745
52							2017	1659
54							<b>1925</b>	1580
56								1507
58								1438
60								<b>1375</b>



**ULTRALIFT** \_ALL INTERMEDIATE LOADS ARE DECREASED OF 10% IF THE CRANE IS NOT EQUIPPED WITH ULTRALIFT CONTROL / SENZA IL SISTEMA ULTRALIFT TUTTE LE PORTATE INTERMEDIE DIMINUISCONO IL CARICO DEL 10% / LES CHARGES INTERMEDIARES SONT DIMINUÉES DE 10% SI LA GRUE N'EST PAS ÉQUIPÉ D'UN CONTROLE ULTRALIFT / SIN EL SISTEMA ULTRALIFT LOS MISAURA INTERMEDIOS DISMINUIR EL CARICO DEL 10% / БЕЗ ULTRALIFT ПРОМЕЖУТОЧНОЙ УМЕНЬШАЕТСЯ НА 10% НАГРУЗКИ.

# MRT 111

## LOAD DIAGRAMS 8.0 T

DIAGRAMMA DI PORTATA / DIAGRAMME DE CHARGE UTILE / CURVAS DE CARGA /  
 ДИАГРАММА ГРУЗОПОДЪЕМНОСТИ

8.000 Kg

JIB	24.0	30.0	36.0	42.0	48.0	50.0	54.0	60.0
1,6 ▶	18.5	18.0	17.5	17.0	16.8	16.8	15.0	13.0
12	8000	8000	8000	8000	8000	8000	8000	8000
14	8000	8000	8000	8000	8000	8000	8000	7598
16	8000	8000	8000	8000	8000	8000	7550	6528
18	8000	8000	7742	7640	7539	7508	6617	5706
20	7289	7192	6885	6794	6703	6676	5877	5056
22	6551	6467	6190	6107	6025	6000	5276	4527
24	<b>5940</b>	5868	5614	5538	5463	5440	4779	4090
26		5363	5129	5060	4990	4969	4360	3722
28		4932	4715	4651	4587	4567	4003	3407
30		<b>4560</b>	4358	4298	4238	4220	3694	3137
32			4047	3991	3935	3918	3425	2900
34			3773	3720	3667	3652	3189	2691
36			<b>3630</b>	3480	3430	3416	2979	2508
38				3266	3219	3205	2792	2343
40				3074	3029	3016	2624	2195
42				<b>2900</b>	2857	2845	2472	2061
44					2702	2690	2334	1940
46					2560	2548	2208	1829
48					<b>2430</b>	2419	2093	1728
50						<b>2300</b>	1988	1635
52							1890	1550
54							<b>1800</b>	1470
56								1397
58								1329
60								<b>1265</b>







+ 60 Kg

ULTRALIFT \_ALL INTERMEDIATE LOADS ARE DECREASED OF 10% IF THE CRANE IS NOT EQUIPPED WITH ULTRALIFT CONTROL / SENZA IL SISTEMA ULTRALIFT TUTTE LE PORTATE INTERMEDIE DIMINUISCONO IL CARICO DEL 10% / LES CHARGES INTERMEDIAIRES SONT DIMINUÉES DE 10% SI LA GRUE N'EST PAS ÉQUIPÉ D'UN CONTROLE ULTRALIFT / SIN EL SISTEMA ULTRALIFT LOS MISURA INTERMEDIOS DISMINUIR EL CARICO DEL 10% / БЕЗ ULTRALIFT ПРОМЕЖУТОЧНОЙ УМЕНЬШАЕТСЯ НА 10% НАГРУЗКИ.

**HOISTING WINCH INVERTER - PERFORMANCES**

MECCANISMI / MÉCANISMES / MECANISMOS / МЕХАНИЗМЫ

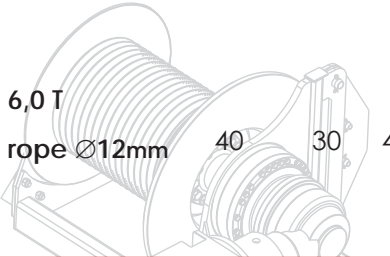
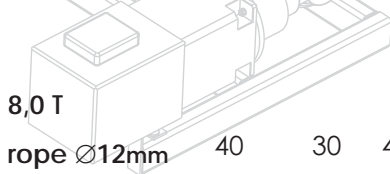
400 VOLT ± 5% - 50Hz \_DIRECTIVE 14/12 - 2005/88/CE

HOISTING WINCH ARGANO	POWER POTENZA CV-ch Ps-hp kW	ROPE FUNE m.	STEP MARCIA	LOAD CARICO Kg.	 SPEED VELOCITÀ m/min.	LOAD CARICO Kg.	 SPEED VELOCITÀ m/min.	
 6,0 T rope Ø12mm	40	30	240 450 LB	1	3000	7	6000	3,5
				2	3000	25	6000	12,5
				3	3000	43	6000	21,5
				4	1500	68	3000	34
				5	1000	93	2000	46,5
				5 (*)	600 (*)	100	1200	50
 8,0 T rope Ø12mm	40	30	240 450 LB	1	4000	7	8000	3,5
				2	4000	25	8000	12,5
				3	4000	43	8000	21,5
				4	2200	68	4400	34
				5	1300	93	2600	46,5
				5 (*)	600	100	1200	50
 8,0 T rope Ø12mm	60	45	780 LB	1	4000	8	8000	4
				2	4000	24	8000	12
				3	4000	40	8000	20
				4	2200	64	4400	32
				5	1300	80	2600	40
				5 (*)	600	96	1200	48

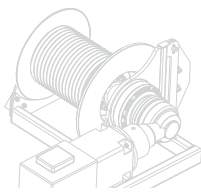

30 kW

45 kW

**ABSORPTIONS / ASSORBIMENTI**

35 kW

47 kW



SLEWING

 0,23 / 0,47 / 0,71 min<sup>-1</sup>

2 X 4 kW



TROLLEY

14,0/ 39,0/ 63,0/ 79,0 (\*) m/min

5,5 kW

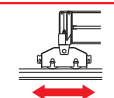

TRAVELLING















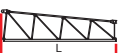

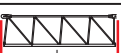



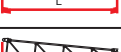

18 m/min

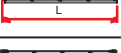
2 X 3 kW

(\*) SPEED AUTOMATICALLY CONTROLLED BY A CURRENT SENSOR / VELOCITÀ REGOLATA AUTOMATICAMENTE DA SENSORE DI CORRENTE / VITESSE RÉGLÉE AUTOMATIQUÉMENT PAR CAPTEUR DE COURANT / ACELERAR CONTROLADO AUTOMÁTICAMENTE POR UN SENSOR DE CORRIENTE / СКОРОСТЬ АВТОМАТИЧЕСКИ РЕГУЛИРУЕТСЯ ДАТЧИКОМ ТОКА



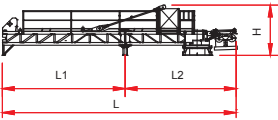

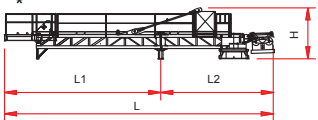
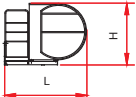
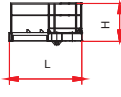





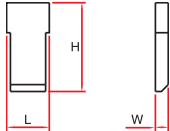

## PACKING LIST

LISTA DEI COLLI / LISTE DE COLISAGE / LISTA DE CONTENIDO / ВЕС И ГАБАРИТНЫЕ РАЗМЕРЫ

DESCRIPTION DENOMINAZIONE	ITEM POS.	PIECES PEZZI	DRAWING DISEGNO	DIMENSIONS mm			WEIGHT kg			
				L	W	H	UNIT	TOTAL		
JIB ELEMENT / ELEMENTO DI FRECCIA / ELÈMENT DE FLÈCHE / ELEMENTO DE FLECHA / элемент стрелка	1	1	n. 1			11,960	1,200	2,380	2164	-
		1	n. 2			6,110	1,200	2,070	773	-
		1	n. 3			6,100	1,200	2,070	741	-
		1	n. 4			6,070	1,200	1,660	574	-
		1	n. 5			6,030	1,200	1,640	501	-
		1	n. 6			6,030	1,200	1,640	453	-
		1	n. 7			6,015	1,200	1,620	437	-
		1	n. 8			5,985	1,200	1,070	387	-
		2	n. 9A - B			2,985	1,200	1,070	184	368
JIB POINT / PUNTALE FRECCIA / ELÈMENT POINTE / PUNTALE DE FLECHA / наконечник стрелка	1				2,860	1,200	1,070	188	-	
COUNTERJIB-TOURNABLE, HOISTING WINCH, TROLLEY JIB, ELECTRICAL BOX. TERMINAL ELEMENT* / CONTROFRECCIA-GIREVOLE, ARGANO SOLL., QUADRO ELETTR., CARRELLO FRECCIA, PORTABLOCCHI* / CONTREFLÈCHE TOURNANTE, TREUIL DE LEVAGE, CHARIOT DE FLÈCHE, ARMOIRE ELECTRIQUE, ELÈMENT TERMINAL* / CONTRAFLECHA GIRATORIO, CABRESTANTE DE ELEVACIÓN, CUADRO ELÉCTRICO, CARRO FLECHA / кохтрстрела-вращения, лебедка, электрические, корзина стрелки, блокодержатель*	2	1			L 1	6,25	2,230	2,550	3300	-
L 2					5,65	2,230	2,550	3915	-	
L					11,900	2,230	2,550	6885	-	
		L 1	7,85	2,230	2,550	3850	-			
		L 2	5,65	2,230	2,550	3915	-			
		L	13,500	3,380	2,550	7765	-			
ACCESS BALCONY, CABIN / BALLATOIO CABINA, CABINA / PORTE CABINE / BALCÓN CORRIDO CABINA, CABINA / площадка кабины, кабина	1				3,050	1,990	2,295	963	-	
TERMINAL ELEMENT / ELEMENTO PORTABLOCCHI / ELÈMENT TERMINAL / PORTABLOQUES / блокодержатель	3	1			2,580	2,278	1,485	540	-	

**PACKING LIST**

LISTA DEI COLLI / LISTE DE COLISAGE / LISTA DE CONTENIDO / ВЕС И ГАБАРИТНЫЕ РАЗМЕРЫ

DESCRIPTION DENOMINAZIONE	ITEM POS.	PIECES PEZZI	DRAWING DISEGNO		DIMENSIONS mm			WEIGHT Kg	
					L	W	H	UNIT	TOTAL
COUNTERWEIGHT BLOCK / BLOCCHI DI CONTRAPPESO / CONTRE-POIDS / BLOQUES DE CONTRAPESO/ блок противовеса	4	4		A99+3	1,430	0,265	2,800	2131	8524
		4		B99+3	1,430	0,210	2,800	1684	6736
TOWER ELEMENT / ELEMENTO DI TORRE ELÈMENT DE MATURE / ELEMENTO DE TORRE / башенный элемент	5	-			2,950	1,700	1,500	1400	-
	6	-			4,425	1,700	1,500	1590	-
	7	-			5,900	1,700	1,500	2155	-
	8	-			11,800	1,700	1,500	3870	-
EXPENDABLE FOUNDATION ELEMENT / TRONCHETTO DI FONDAZIONE / ELÈMENT A SCELLER / TRONCO DE FUNDACIÓN / СТВОЛ ОСНОВАНИЯ	9	1			1,465	1,780	1,780	780	-
BASE MAIN BEAM / TRAVE PRINCIPALE CROCIERA DI BASE / POUTRE DE CHASSIS DE BASE / VIGA PRINCIPAL DE LA CRUCETA DE BASE / главная балка крестовины основания	10	1		4,5 x 4,5 m	6,530	0,710	0,760	2450	-
				3,8 x 3,8 m	5,535	0,710	0,760	1460	-
HALF BASE BEAM / SEMITRAVE DI BASE / SEMIPOUTRE DE CHASSIS DE BASE / MEDIA VIGA DE LA CRUCETA DE BASE / полубалка крестовины основания	11	2		4,5 x 4,5 m	3,200	0,590	0,770	1090	2180
				3,8 x 3,8 m	2,620	0,590	0,770	940	1880
CONCRETE PAD / BLOCCO DI APPOGGIO / SABOT EN BÊTON / BLOQUE DE APOYO / опорный блок	12	4			3,600	0,800	0,600	3925	15700
DRIVING BOGIE / BILANCINO TRASL. FOLLE / BOGGIE FOU / BALANCÍN DE TRASLACIÓN LOCO/ не приводной баланси́р для горизонтального перемещения	13	2			1,080	0,230	0,515	416	832
DRIVEN BOGIE / BILANCINO TRASLAZIONE MOTORIZZATO / BOGGIE MOTORISÉÉ / BALANCÍN DE TRASLACIÓN MOTORIZADO / приводной баланси́р горизонтального перемещения	14	2			1,550	0,500	0,515	535	1070
BASE BALLAST BLOCK / BLOCCO DI ZAVORRA / LEST DE BASE / BLOQUE DE LASTRE / блок балласта	15	-			3,600	1,200	0,300	2950	-



# MRT 111

## PACKING LIST

LISTA DEI COLLI / LISTE DE COLISAGE / LISTA DE CONTENIDO / ВЕС И ГАБАРИТНЫЕ РАЗМЕРЫ

DESCRIPTION DENOMINAZIONE	ITEM POS.	PIECES PEZZI	DRAWING DISEGNO	DIMENSIONS mm			WEIGHT kg		
				L	W	H	UNIT	TOTAL	
<b>CITY 1,7 m</b>									
TOWER ELEMENT 1,7/1,5m ELEMENTO DI TORRE 1,7/1,5m ELÈMENT DE MATURE 1,7/1,5m ELEMENTO DE TORRE 1,7/1,5m башенный элемент 1,7/1,5m	16	-		5,900	1,700	1,900	2205	-	
	17	-		2,950	1,900	1,700	1350	-	
TOWER ELEMENT / ELEMENTO DI TORRE ELÈMENT DE MATURE / ELEMENTO DE TORRE / башенный элемент	18	-		5,900	1,900	1,700	2295	-	
	19	-		11,800	1,900	1,700	4175	-	
EXPENDABLE FOUNDATION ELEMENT / TRONCHETTO DI FONDAZIONE / ELÈMENT A SCELLER / TRONCO DE FUNDACIÓN / СТВОЛ ОСНОВАНИЯ	20	1		1,465	1,980	1,980	830	-	
BASE MAIN BEAM / TRAVE PRINCIPALE CROCIERA DI BASE / POUTRE DE CHASSIS DE BASE / VIGA PRINCIPAL DE LA CRUCETA DE BASE / главная балка крестовины ОСНОВАНИЯ	21	1		4,5x4,5 m 6,0x6,0 m	6,524	0,780	0,960	2595	- 3475
HALF BASE BEAM / SEMITRAVE DI BASE / SEMIPOUTRE DE CHASSIS DE BASE / MEDIA VIGA DE LA CRUCETA DE BASE / полубалка крестовины ОСНОВАНИЯ	22	2		4,5x4,5 m 6,0x6,0 m	3,212	0,680	0,974	1235	2470 3490
CONCRETE PAD / BLOCCO DI APPOGGIO / SABOT EN BÉTON / BLOQUE DE APOYO / опорный блок	23	4		3,600	0,900	0,750	5520	22080	
DRIVING BOGIE / BILANCINO TRASLAZIONE FOLLE / BOGGIE FOU / BALANCÍN DE TRASLACIÓN LOCO / не приводной балансир для горизонтального перемещения	24	2		1,315	0,222	0,540	600	1200	
DRIVEN BOGIE / BILANCINO TRASLAZIONE MOTORIZZATO / BOGGIE MOTORISÉE / BALANCÍN DE TRASLACIÓN MOTORIZADO / приводной балансир горизонтального перемещения	25	2		1,427	0,492	0,540	765	1530	

**INTERNAL CLIMBING**

GRU IN CAVEDIO / TÉLESCOPAGE SUR DALLES / GRUA EN CAVEDIO / ПОДНИМАЮЩИЙСЯ НА ПЛИТАХ ПЕРЕКРЫТИЯ

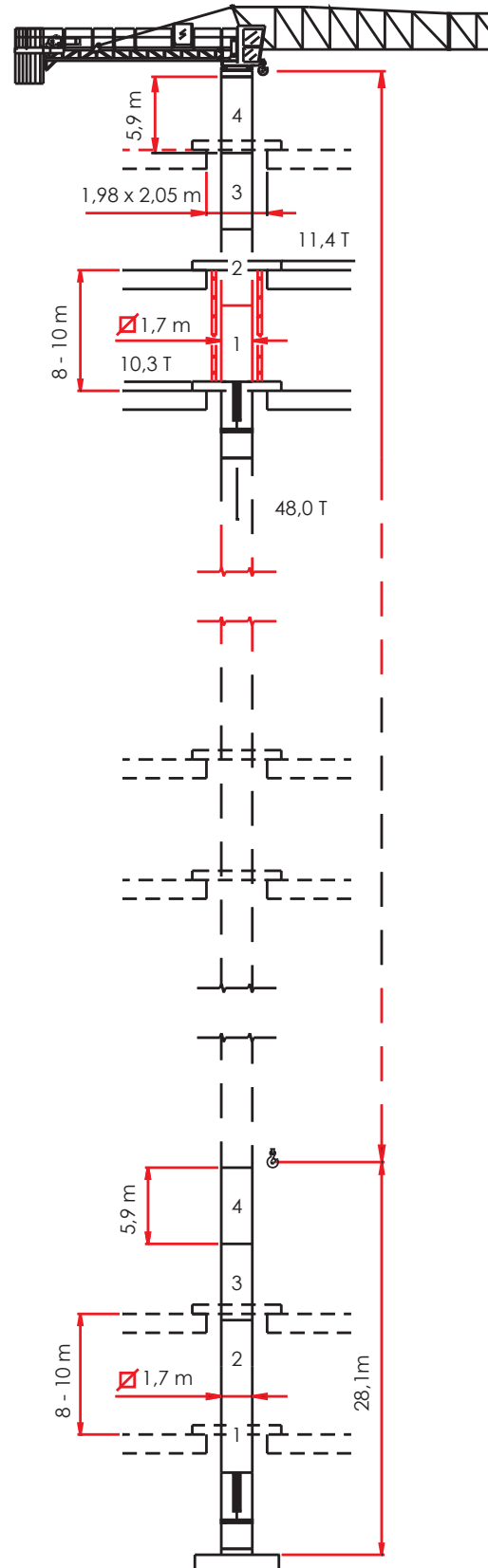

# MRT 111

## EXTERNAL CLIMBING

SOPRALZO IDRAULICO / TELESOPABLE / ELEVACIÓN HIDRÁULICA / ГИДРАВЛИЧЕСКОЕ НАРАЩИВАНИЕ

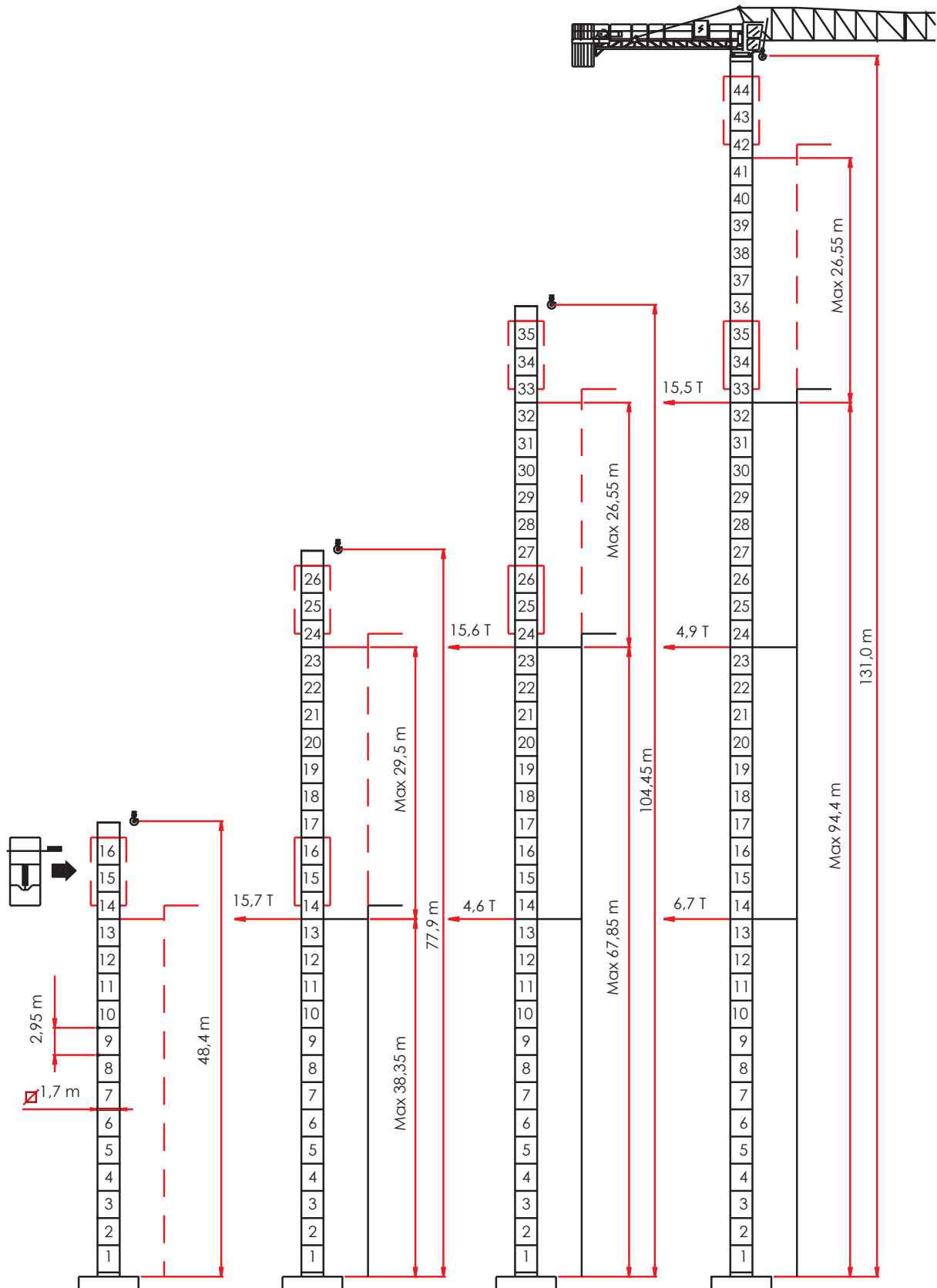

[ MRT 111 \_REV. \_0312 ] ADL / TECHNICAL DEPARTEMENT

---

THE DATA OBJECT OF THESE SHEETS ARE SUBJECT TO CHANGE WITHOUT PRIOR NOTICE / I DATI OGGETTO DELLE PRESENTI SCHEDE POTREBBERO SUBIRE MODIFICHE SENZA PREAVVISO / LES INFORMATIONS DONNÉES DANS LES PRÉSENTES FICHES POURRAIENT SUBIR DES MODIFICATIONS SANS PRÉAVIS / LOS DATOS CONTENIDOS EN ESTE FORMULARIO ESTÁN SUJETAS A CAMBIOS SIN PREVIO AVISO / ДАННЫЕ, УКАЗАННЫЕ В НАСТОЯЩИХ СПЕЦИФИКАЦИЯХ, МОГУТ ИЗМЕНЯТЬСЯ БЕЗ ПРЕДВАРИТЕЛЬНОГО ПРЕДУПРЕЖДЕНИЯ.