

Grove GMK6350L

Preliminary Product Sales Guide



Grove GMK6350L

Preliminary Quick Reference

Capacity: 300 t (350 USt)
Boom: 15,6 m - 80 m (51 ft - 263 ft) main boom
Max jib: 37 m (121 ft)
Max tip height: 120 m (393 ft)

FEATURES

- MEGAFORM™ boom with TWINLOCK™ pinning
- 12 m - 21 m (39 ft - 69 ft) hydraulic offset bi-fold swingaway and 2 x 8 m (26 ft) intermediate lattice insert
- 92,5 t (203,900 lb) counterweight with hydraulic removal system
- MEGATRAK™ independent hydro-pneumatic suspension

Load chart

15,6 m - 80 m (51.1 ft - 262.5 ft)
 92 500 kg (203,900 lb)
 26 ft 7 in spread (100%)
 360°

Pounds x 1000

Feet	51.1'	68.7'	86.1'	103.4'	120.8'	138.1'	156.3'	173.5'	191.6'	209.5'	227.4'	245.3'	262.5'
8.0	700.0°												
10.0	416.0	335.0											
15.0	336.0	316.0	294.0										
20.0	275.0	271.0	256.0	229.0	177.0								
25.0	232.0	231.0	223.0	215.0	177.0	139.0							
30.0	199.0	198.0	196.0	190.0	175.0	139.0	110.0	84.0					
35.0	169.0	169.0	168.0	167.0	161.0	137.0	110.0	84.0	64.0				
40.0		144.0	144.0	143.0	145.0	128.0	106.0	84.0	64.0	50.0	38.8		
45.0		127.0	125.0	124.0	126.0	118.0	101.0	83.0	64.0	50.0	38.8	31.6	
50.0		113.0	112.0	110.0	110.0	110.0	96.0	77.0	64.0	50.0	38.8	31.6	26.4
55.0			100.0	99.0	98.0	100.0	91.0	71.0	63.0	50.0	38.8	31.6	26.4
60.0			90.0	89.0	88.0	90.0	85.0	66.0	61.0	50.0	38.8	31.6	26.4
65.0			81.0	79.0	78.0	81.0	80.0	60.0	57.0	50.0	38.8	31.6	26.4
70.0			72.0	72.0	73.0	73.0	74.0	56.0	53.0	48.0	38.8	31.6	26.4
75.0				66.0	67.0	66.0	68.0	52.0	49.0	46.0	38.8	31.6	26.4
80.0				61.0	62.0	60.0	63.0	49.0	45.0	43.4	38.6	31.6	26.4
85.0				58.0	57.0	55.0	58.0	44.0	42.0	40.4	37.4	31.6	26.4
90.0				47.0	52.0	53.0	53.0	40.6	38.8	37.4	35.6	31.6	26.4
95.0					49.0	50.0	49.0	38.4	36.0	35.0	33.6	31.0	26.4
100.0					45.0	47.0	45.0	37.0	33.6	32.6	31.8	30.0	26.4
105.0						43.8	41.6	35.8	31.2	30.4	30.0	28.6	26.4
110.0						40.6	38.4	34.6	29.4	28.6	28.2	27.4	26.0
115.0						37.8	35.6	33.4	27.4	26.8	26.6	26.0	25.0
120.0							32.8	32.4	25.6	25.0	24.8	24.8	24.0
125.0							30.4	31.4	24.2	23.4	23.2	23.6	23.0
130.0							28.4	30.0	22.6	22.0	21.8	22.2	21.4
135.0								27.6	28.0	20.8	20.2	20.2	19.8
140.0									26.2	19.0	18.6	18.8	18.6
145.0									24.4	17.2	17.4	17.8	17.8
150.0									22.8	16.2	16.8	17.0	16.0
155.0									20.6	15.2	16.2	16.4	15.2
160.0										14.4	15.6	15.8	14.4
165.0										13.8	15.2	15.2	13.8
170.0										13.2	14.6	14.6	13.0
175.0										12.8	14.2	14.2	12.4
180.0											13.6	13.6	11.8
185.0												13.4	11.0
190.0												13.0	10.4
195.0												12.0	9.8
200.0												11.6	9.2
205.0												11.2	9.4
210.0													8.6
215.0													8.6
220.0													7.2
225.0													7.2
230.0													6.0
235.0													5.2
240.0													4.6

Main boom 15,6 m - 80 m (51 ft - 263 ft)

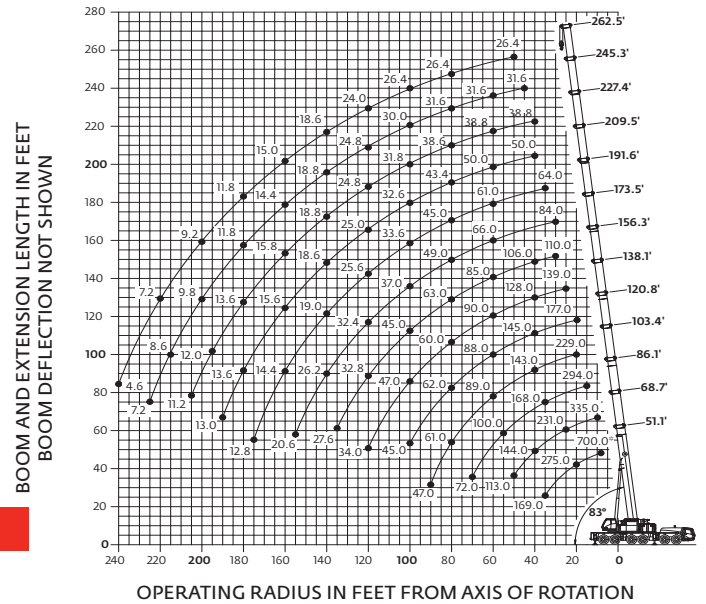

Dimensions

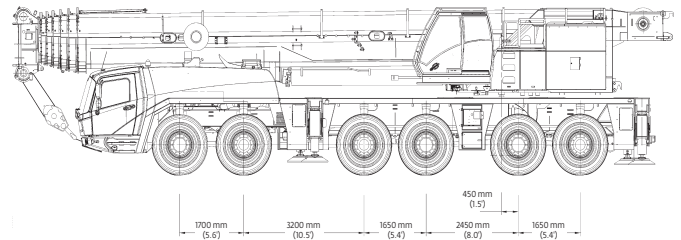

Basic Weights - kg (lb)	Axles 1 and 2	Axles 3 - 6	Total
Mercedes power, 16.00R25 tires, 12x6x12 drive/steer, 2nd oil cooler, outrigger pads, driver and tanks filled	22 927 (50,545)	48 993 (108,011)	71 920 (158,556)
Additions:			
12x8x12 drive/steer	-222 (-489)	612 (1349)	390 (860)
Spare wheel 14.00 R25 XGC steel rim with stowage	-199 (-439)	464 (1023)	265 (584)
Spare wheel 16.00 R25 XGC steel rim with stowage	-244 (-538)	569 (1254)	325 (717)
Spare wheel 20.5 R25 XGC steel rim with stowage	-278 (-613)	645 (1422)	367 (809)
Brackets for hydraulic swingaway	100 (220)	0 (0)	100 (220)
Hose reel + parts for hydraulic swingaway	110 (243)	120 (265)	230 (507)
11 m - 18 m (36 ft - 59 ft) hydraulic swingaway	2525 (5567)	-515 (-1135)	2010 (4431)
Auxiliary hoist	-2509 (-5,531)	5269 (11,616)	2760 (6085)
7000 kg (15,400 lb) base plate stowed on carrier	3662 (8073)	3338 (7359)	7000 (15,432)
9500 kg (20,900 lb) slab on top of base plate stowed on carrier	4970 (10,957)	4530 (9987)	9500 (20,944)
Substitutions:			
14.00R25 tires	-240 (-529)	-480 (-1058)	-720 (-1587)
20.5R25 tires	168 (370)	336 (741)	504 (1111)
Removals:			
Boom assembly without lift cylinder	-17 034 (-37,554)	-10 499 (-23,146)	-27 533 (-60,700)
Front outriggers	-1655 (-3649)	-890 (-1962)	-2545 (-5611)
Rear outriggers	1842 (4061)	-4675 (-10,307)	-2833 (-6246)
Front and rear outrigger floats	0 (0)	-350 (-772)	-350 (-772)

SUPERSTRUCTURE

Boom

15,6 m - 80 m (51 ft - 263 ft) 7-section, full power MEGAFORM™ boom with TWIN-LOCK™ Pinning.

Maximum tip height: 83 m (272 ft).

Boom nose

Nine nylatron sheaves, mounted on heavy duty tapered roller bearings with removable pin-type rope guards. Quick reeve boom nose. Removable auxiliary boom nose with removable pin type rope guard.

Boom elevation

Single lift cylinder with safety valve provides boom angle from -1.5° to +83°.

*Optional offsettable swingaway extension

12 m - 21 m (39 ft - 69 ft) bi-fold lattice swingaway extension, hydraulically offsettable and luffing under load, 5°- 40°. Maximum tip height: 104 m (341 ft)

*Lattice inserts

2 x 8 m (26 ft) insert for use with lattice swingaway extension to increase length to 37 m (121 ft). Maximum tip height: 120 m (393 ft)

Load moment and anti-two block system

Load moment and anti-two block system with audio/visual warning and control lever lockout provides electronic display of boom angle, length, radius, tip height, relative load moment, maximum permissible load, load indication and warning of impending two-block condition.

Cab

All aluminum constructed cab with acoustical lining, hydraulic tilted to 20°. Includes tinted safety glass, adjustable operator's seat, opening windows at side and rear, hinged windshield with wiper, sun visor and window shade. Other features include hot water heater/ defroster, armrest integrated crane controls, ergonomically arranged instrumentation and radio/cd player.

Swing

3 planetary gear boxes with fixed displacement axial piston motors. Infinitely variable to 1.3 rpm. Free swing or hydrostatically engaged brake controlled by swing lever. Swing brake selected by foot operated switch.

Counterweight

92,5 t (203,900 lb) consisting of various sections with hydraulic installation/removal system controlled from the superstructure cab.

Engine

Mercedes OM 926 LA six-cylinder

Horsepower: 210 kW (286 bhp) at 2200 rpm

Torque: 1120 Nm (826 ft/lb) at 1400 rpm

Engine emissions: EPA/CARB/ EUROMOT (off road)

Fuel tank capacity

300 L (79 gal)

Electrical system

3 phase alternator: 28V/80A

2 batteries: 12V/170Ah

Hydraulic system

2 (two) separate circuits, 1 (one) axial piston variable displacement pump (load sensing) with electronic power limiting control for crane functions and 1 (one) double gear pump for slewing. Thermostatically controlled oil coolers keep oil at optimum operating temperature.

Hydraulic tank capacity: 1200 L (317 gal)

Hoist

Main and auxiliary hoist are powered by axial piston motor with planetary gear and brake. "Thumb-thumper" hoist drum rotation indicator alerts operator of hoist movement.

	Main	Auxiliary
Rope length	350 m (1148 ft)	350 m (1148 ft)
Rope diameter	22 mm	22 mm
Line speed	127 m/min (417 fpm)	127 m/min (417 fpm)
Line pull	93.5 kN (21,020 lb)	93.5 kN (21,020 lb)

Hoist camera and light included.

CARRIER

Chassis

Box type, torsion resistant frame is fabricated from high strength steel.

Outrigger system

Four hydraulic two stage outrigger beams with vertical cylinders and outrigger pads, 700 mm (27.6 in) round. Outrigger can be set in 5 positions:

Full: 8,5 m (27.9 ft)

Partial: 7,4 m (24.3 ft)

Partial: 6,3 m (20.7 ft)

Partial: 5,0 m (16.4 ft)

Retracted: 2,7 m (9.0 ft)

Independent horizontal and vertical movement controlled from each side of carrier and the superstructure cab. Electronic crane level indicators. Hydraulic disconnect for all outrigger beams. Work light for each outrigger beam and outrigger pad load indicator with read out on both sides of carrier and in superstructure cabin.

Transmission

Allison automatic 4500 SP; 6 speeds forward, 1 reverse

2 speed transfer case

Drive/steer

12x6x12

Axles

1st axle line – drive/steer

2nd axle line – steer

3rd axle line – steer (connects for all wheel steer)

4th axle line – drive/steer (connects for all wheel steer)

5th axle line – drive/steer (permanent drive with 12x6, disconnects for highway with 12x8)

6th axle line – steer (optional drive)

Drive axles with planetary hub reduction and center mounted gearing. Standard inter-axle and cross axle differential locks.

Suspension

Grove exclusive MEGATRAK™ suspension. Independent hydro-pneumatic system acting on all wheels with hydraulic lockout. Suspension can be raised 170 mm (6.7 in) or lowered 126 mm (5.0 in), both longitudinally and transversely. Features an automatic leveling system for highway travel.

Tires

12 tires, 16.00R25 (Vehicle width – 3,0 m [9.8 ft])

Steering

Dual circuit, hydraulic power assisted steering system. Transfer case mounted, ground driven emergency steering pump. Axles 1, 2, 5 and 6 steer on highway. Separate steering (steer by wire) of the 3rd to 6th axles for all wheel and crab steering, controlled by an electronic rocker switch.

Engine

Mercedes OM 502 LA, eight-cylinder

Horsepower: 405 kW (551 bhp) at 2100 rpm

Torque: 2600 Nm (1918 ft/lb) at 1300 rpm

Engine emissions: EPA /CARB/ EUROMOT (off road)

Fuel tank capacity

500 L (132 gal). Installed on superstructure.

Brakes

Service brakes: pneumatic dual circuit acting on all wheels.

Parking brake: pneumatically operated spring loaded brake acting on axle lines 2, 4, 5 and 6.

Air dryer.

Cab

Two-man, composite designed aluminum and fiber reinforced plastic construction with the following features: safety glass, driver seat with pneumatic suspension, engine-dependent hot water heater, power windows, heated rear view mirrors, complete instrumentation, driving controls, reversing camera system, air conditioning, radio/cd player, 12V plug and fire extinguisher.

Electrical system

24V system with three phase alternator, 28V/100A

2 batteries, 12V/170 Ah

Maximum speed

85 km/h (53 mph)

Gradeability (theoretical)

49% - 14.00 tires

43% - 16.00/20.5 tires

Miscellaneous standard equipment

Work lights; tool kit, fire extinguishers; auxiliary boom nose and wind speed indicator.



GMK6350L

Grove Mobile Crane Product Line

**GMK6350L: *THE strongest 6 axle with 263 ft
[80m] boom***



Carrier specification overview

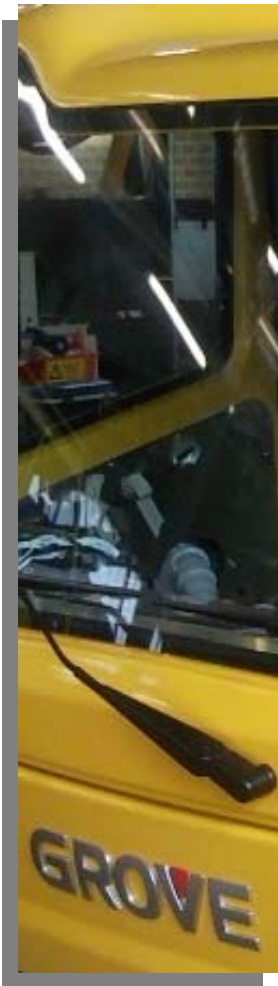

- Engine: Mercedes OM 502 LA, 8 cylinder
 - Tier 4i: 543 HP [405 kW] at 1.800 rpm
 - Fuel capacity: 132 gal [500 l]
(build in superstructure)
- Transmission: Allison 6-speed automatic transmission (4500SP)
Kessler 2speed transfer case (VG2600)
- Suspension: MEGATRAK™ +6.3"/-4.7" [+160/-120 mm]
- Outriggers: 27.9 ft [8.5 m], stroke 1.8 ft [0.55m], 5 positions
- Driver Cab: new designed two (three) man glass fiber - aluminum cabin
- Steering: latest "Steer by wire" – technology on 5th and 6th axle

Superstructure specification overview

- Boom: 262 ft [80 m] 7-section with Grove MEGAFORM™ boom
- Engine: Mercedes OM 926 LA, 6 cylinder
282 HP [210 kW] at 1.200 – 1.600 rpm
Fuel capacity: 79 gal [300 l]
- Control: ECOS, EKS 5 full graphic display
- Cabin: New style full vision 20° tilt aluminum cab
- Hoists: Drum style 22mm, line pull 23,380 lb [104 kN]
1083 ft [330 m] rope length (3 lines to ground on long boom)



Engine: Mercedes-Benz in carrier (OM502LA) and superstructure (OM926LA)

Latest engine technology including Tier 4i [stage Euromot IIIb]



- Water-cooled diesel engine:
- Turbocharged with intercooler
 - High pressure fuel-injection system with unit injection pumps controlled by solenoid valves
 - Electronic engine management
 - OM 502 LA with 8 cylinder and 543 HP [405 kW]
 - OM 926 LA with 6 cylinder and 282 HP [210 kW]
 - Selective Catalytic Reduction – reduces the NO_x by 80%

Transmission: Full automatic Allison 4500 SP with retarder*

„strong, reliable and cost effective solution“

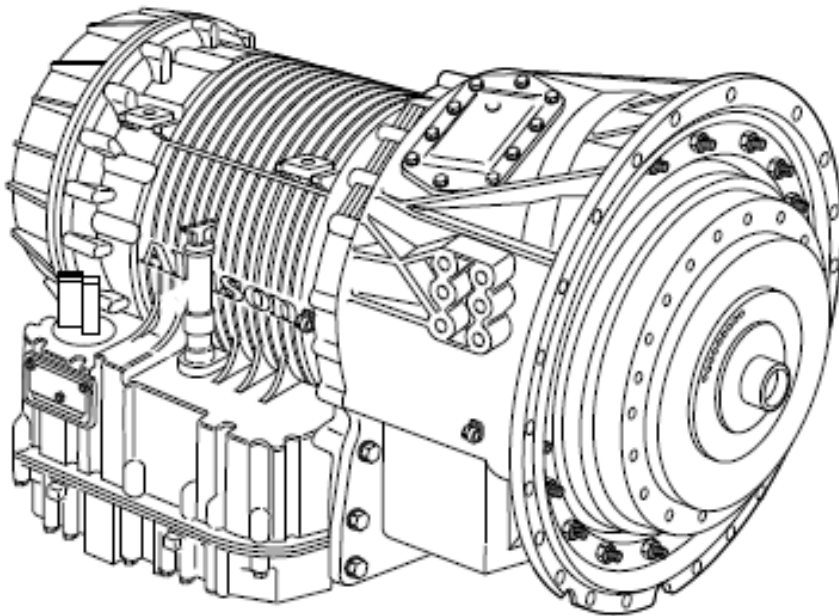

Allison automatics have been moving earth, in mines, construction sites, quarries, gravel pits for more than fifty years. They've proven to be durable and reliable in the most arduous duty cycles.

The technologically advanced electronic controls are programmed for the specific mobile crane situations and offer self diagnostic ability for easier maintenance.

Allison's integral retarder* is part of the transmission and provides enhanced vehicle braking on hills, and while slowing a vehicle with a heavy load.

Weights (preliminary)

PRELIMINARY!

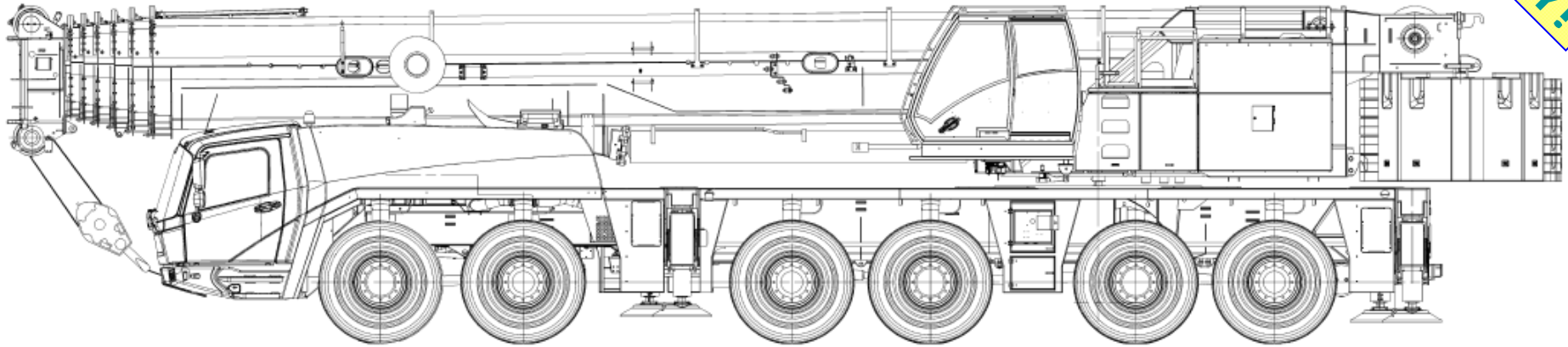

Axles 1-2
52,067 lb
26,034 per axle

Axles 3-6
109,284 lb
27,321 per axle

GVW
161,351 lb

Unit configuration

51-262 ft boom / 12 X 8 X 12 (drive/steer) / retarder / main hoist with cable / 20.5" tires / additional oil cooler / outrigger pads stowed on unit / no counterweight / all outriggers / no ROB

→ **Very similar GVW and weight distribution as GMK6350!**

GMK 6350 in same configuration: GVW 160,988 lb (Front 51,673 lb / Rear 3-6 109,314 lb)

Product dimensions of carrier

Height: 13.1 ft [4 m]
(16", 20.5" tires)

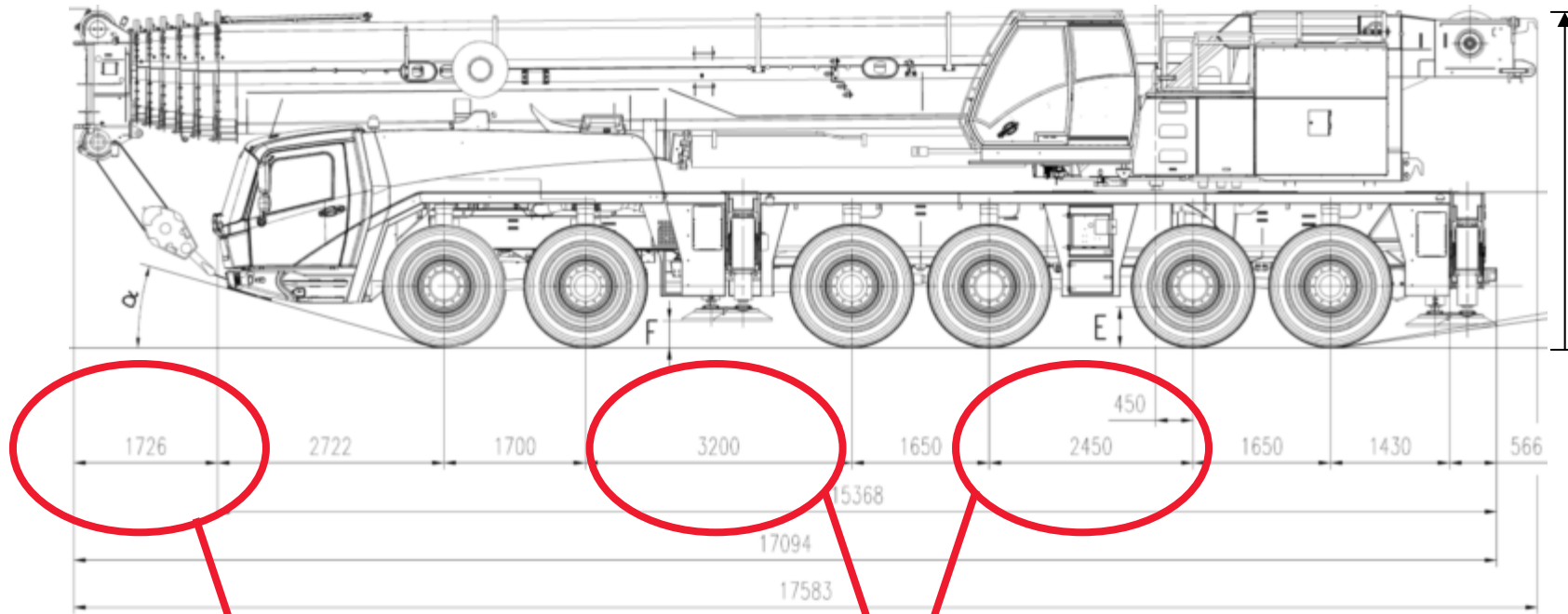

Very good overhang - under 6 ft [2 m].

Ideal axle spread – more than 8 ft [2,45 m].

The competition has bigger overhang:
LTM1250-6.1 (> 6 ft [2 m])
LTM1350-6.1 (> 6 ft [2 m])

Product dimensions: Turning radius - preliminary

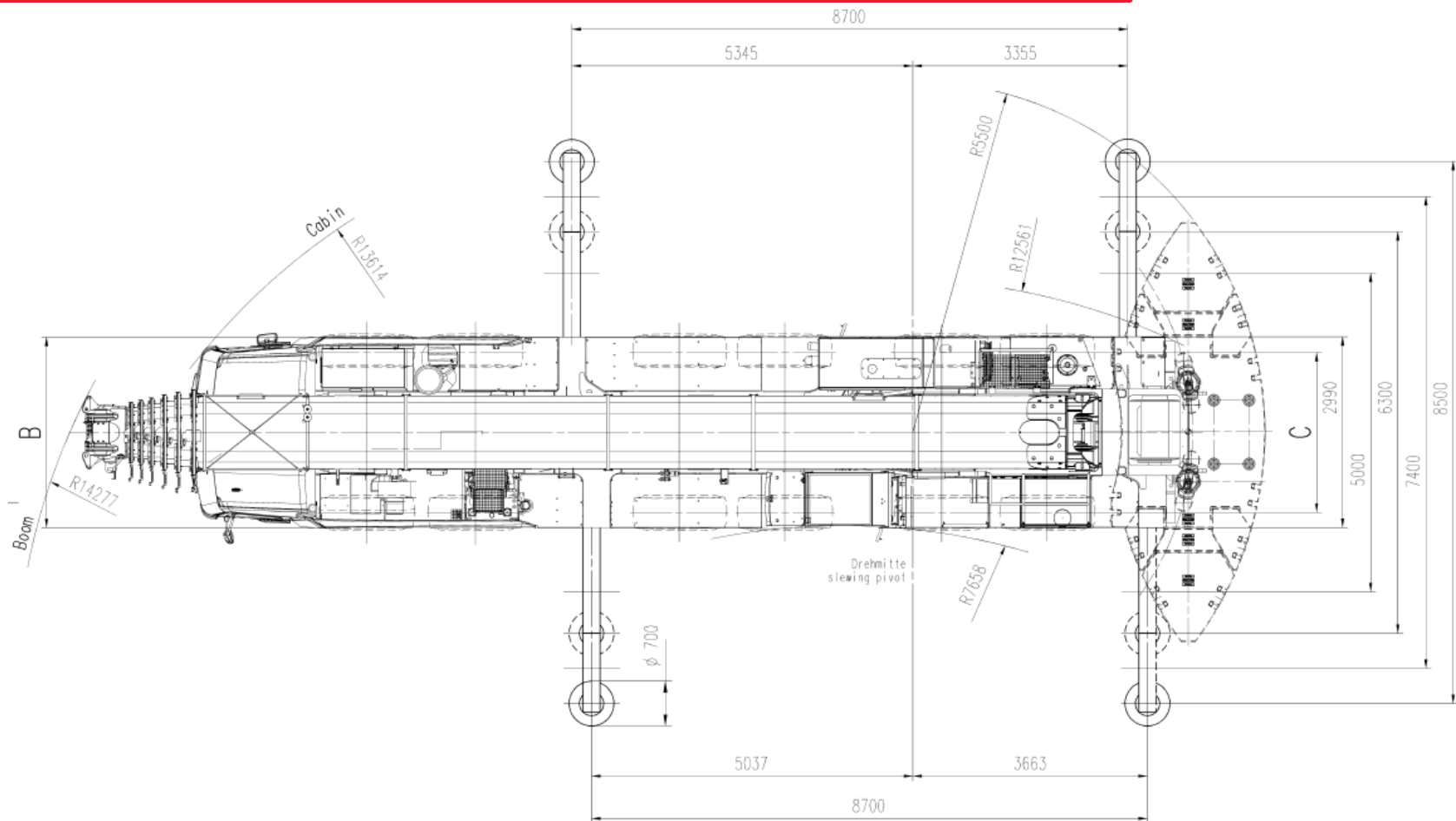

Product dimensions: Outrigger spread

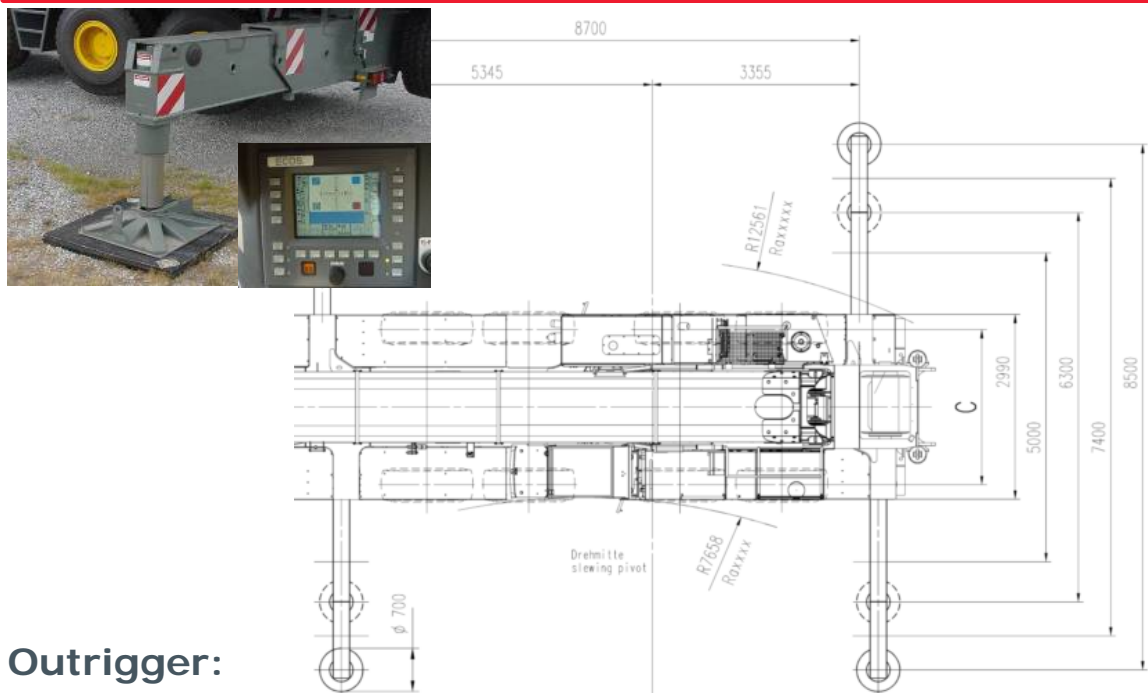

Outrigger:

- Double box, 2 stage
- Electronic level indicators with automatic leveling system
- Carrier mounted controls and ECOS controlled from the superstructure
- Conveniently stowed outrigger floats

→ Standard outrigger pad load indicator

5 position outrigger span:

- Full 100% – 27.9 ft [8.5 m]
- Partial 83% – 24.3 ft [7.4 m]
- Partial 66% – 20.7 ft [6.3 m]
- Partial 50% – 16.4 ft [5.0 m]
- Retracted 0% – 8.9 ft [2.7 m]

→ Ultimate flexibility:

Easy adaptation of the width to the required working area to maximize efficiency.

The competition has less flexibility:
 LTM1250-6.1 (3 outrigger positions)
 LTM1350-6.1 (4 outrigger positions)
 AC250-1 (4 outrigger positions)
 AC300/6 (4 outrigger positions)

Outrigger Controls / Handset

Emergency Stop

Emergency Crane Control (By-pass Cab)

Swingaway Rigging

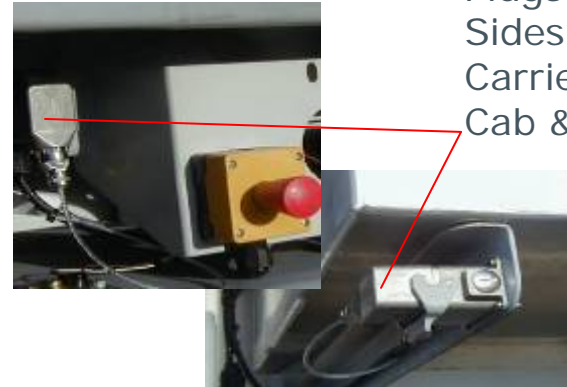

Plugs in Both Sides of Carrier, Super Cab & Boom

NEW Chassis outrigger control boxes

Outrigger Controls

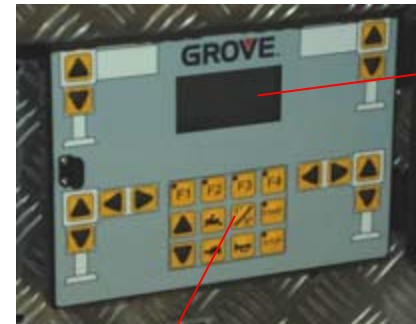

Standard Pressure Read-out

Suspension controls for improved rigging!

Superstructure and counterweight

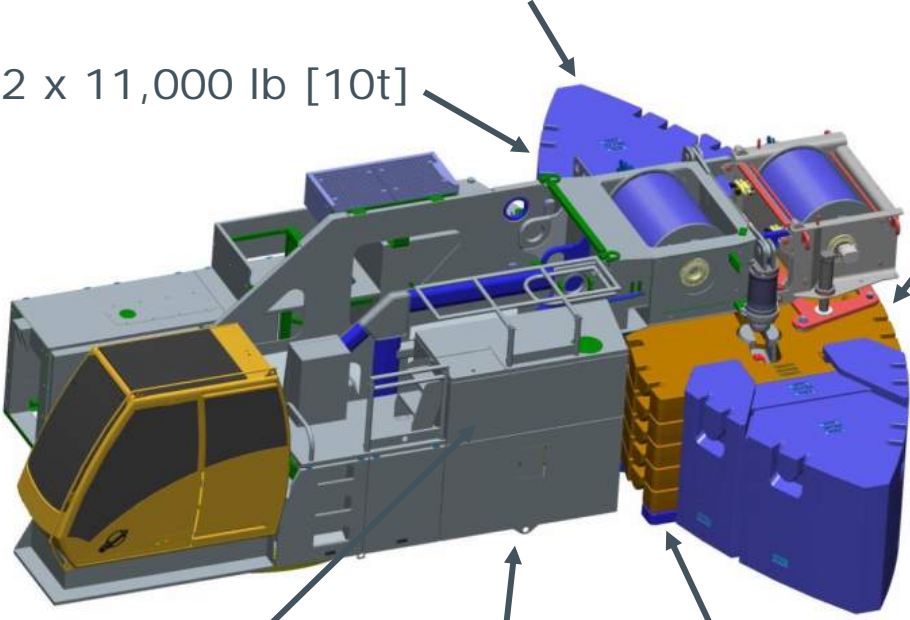
- 
- 2 x 19,850 lb [9t]
 - 2 x 11,000 lb [10t]
 - 5 x 20,950 lb [9,5t]
 - 79 gal [300 liters] for super
 - 132 gal [500 liters] for carrier
 - 15,450 lb [7t] base plate

> 11,000 lb [10t]
counterweight **slabs and wing weights** optimized for transport and a **self rigging auxiliary hoist** for rigging without the need of an auxiliary crane.

Boom technology: Grove patented MEGAFORM™

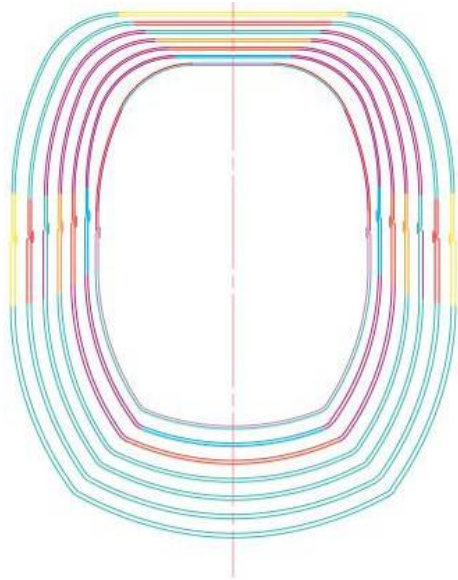

No Stiffeners on Base Section
→ Saves Weight without loss
of capacity
160KSI [1100 n/mm²] Steel



7 Section 51 ft – 262 ft
[15,6 - 80 m] Boom
(with MEGAFORM™ Shape
Base Section)

Boom extensions

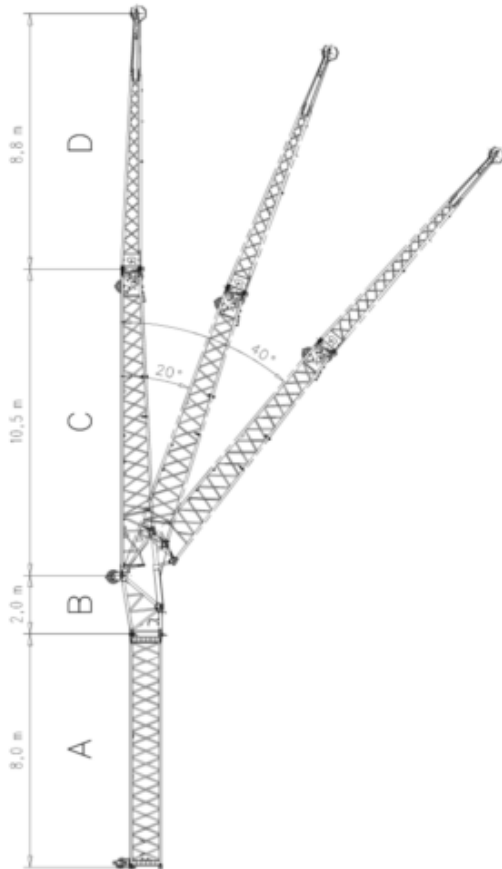

Optional Equipment

- Bi-fold swingaway, 39-69 ft [12-21 m] with hydraulic offset and luffing under load (5-40°), controlled from the crane cab.
- Lattice extensions, 2 x26 ft [8 m] – for 95 ft [29 m] total boom extension in combination with 39-69 ft [12-21 m] swingaway. Maximum tip height 354 ft [107.7m].
- 7.5 ft [2.3 m] side stowed heavy duty jib [83,800 lb (38t) max capacity]. Offset 8 and 30°

Total length	Intermediate section boom extension make-up			
ft [m]	26.2 [8,0]	6.6 [2,0]	34.4 [10,5]	28.9 [8,8]
39.4 [12,0]	-	1x	1x	-
68.9 [21,0]	-	1x	1x	1x
95.1 [29,0]	1x	1x	1x	1x

Heavy Duty Jib

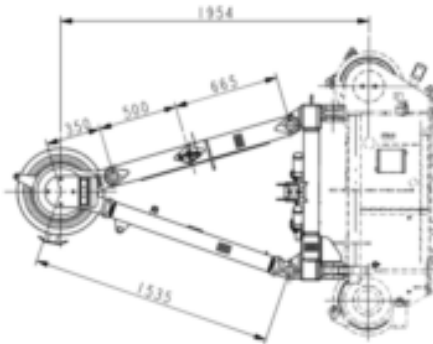

- Offsettable jib to 8° and 30°
- 2 sheaves
- max. capacity 83,700 lb [38 t]
- Stub jib can be stowed on side of main boom (left hand side); swingaway right hand side

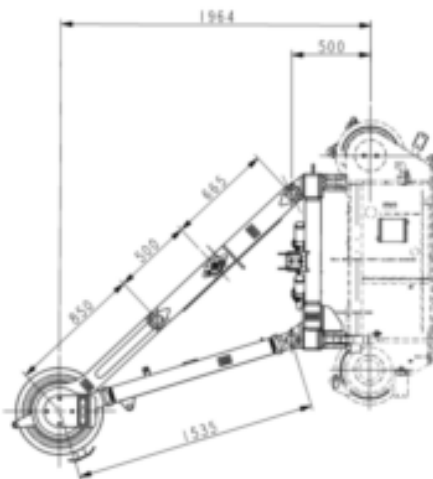

Strong loadcharts and high flexibility
due to offset angle – this gives
strength on short and long radius.

New carrier cabin for wide carrier frames

- Adaption of new look of drivers cabin from big AT cranes
- More driving comfort and better ergonomic instrumentation for driver
- Improving heating- and cooling system with air-condition as standard
- Better visibility thru cabin width
- Better aerodynamic
- Noise reduction
- Increased quality
- Rust resistant glass-fibre and aluminum composite



New serial specification

Carrier

- Air condition in carrier cabin
- Outrigger pad load indicator with read out on superstructure and carrier
- CraneStar fleet management
- One additional strobe light
- Reversing camera system
- LMI status display (EN13000)
- Stereo radio/ CD Player
- Work lights for outrigger beams
- Suspension control in outrigger control boxes

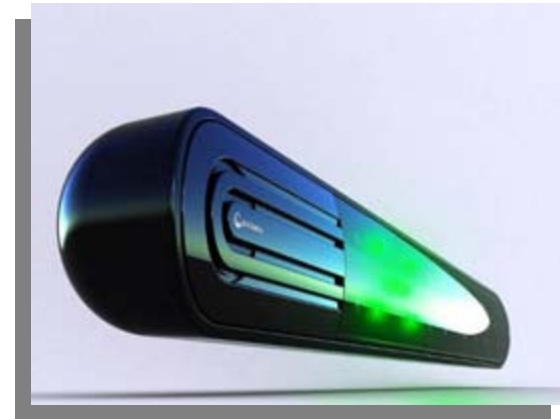

Superstructure

- Hoist camera incl. light
- Second spotlight on superstructure cab
- Stereo radio/ CD player
- One additional strobe light

Crane Star

CraneSTAR A fleet management tool with several customer benefits!



helps to **monitor cranes**, working sites, warehouses, or fleet productivity (% use, misuse,...)

gives knowledge to help making **fact-based decisions** regarding on productivity; be more proactive in scheduling preventive maintenance, and make better decisions about equipments

increases security, which may lead to reduced insurance costs

allows to use data to prove the proper use of cranes to create an **higher resale value**

Lifting specification for various applications with long reach

Full counterweight 92.5t, max. outrigger base 8,70x8,50m

Feet	51.1	86.1	120.8	156.3	191.6	227.4	245.3	262.5
8.0	700.0*							
10.0	416.0							
15.0	336.0	294.0						
20.0	275.0	256.0	177.0					
25.0	232.0	223.0	177.0					
30.0	199.0	196.0	175.0	110.0				
35.0	169.0	168.0	161.0	110.0	64.0			
40.0		144.0	145.0	106.0	64.0	38.8		
45.0		125.0	126.0	101.0	64.0	38.8	31.6	
50.0		112.0	110.0	96.0	64.0	38.8	31.6	26.4
55.0		100.0	98.0	91.0	63.0	38.8	31.6	26.4
60.0		90.0	88.0	85.0	61.0	38.8	31.6	26.4
65.0		81.0	78.0	80.0	57.0	38.8	31.6	26.4
70.0		72.0	73.0	74.0	53.0	38.8	31.6	26.4
75.0			67.0	68.0	49.0	38.8	31.6	26.4
80.0			62.0	63.0	45.0	38.6	31.6	26.4
85.0			57.0	58.0	42.0	37.4	31.6	26.4
90.0			52.0	53.0	38.8	35.6	31.6	26.4
95.0			49.0	49.0	36.0	33.6	31.0	26.4
100.0			45.0	45.0	33.6	31.8	30.0	26.4
105.0				41.6	31.2	30.0	28.6	26.4
110.0				38.4	29.4	28.2	27.4	26.0
115.0				35.6	27.4	26.6	26.0	25.0
120.0				32.8	25.6	24.8	24.8	24.0

Tower crane rigging.



Lifting of aircon or elevator equipment

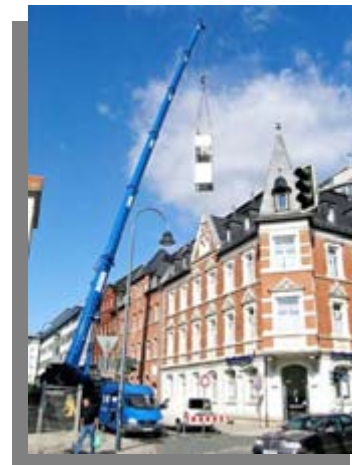

Loadcharts: Tower crane rigging as the focus

MDT308

230 ft Jib = **31,500 lb**; Slewing ring (pivot) = 21,800lb

Max Height Under Hook = **213 ft**

Competitors cranes:

- *Liebherr: 250 EC-B 12 LITRONIC*
- *Wolffkran: 6531.12*
- *Terex: CTT231 12*



MD265C

213 ft jib = **28,200 lb**; Slewing ring (pivot) = 11,700 lb

Max Height Under Hook = **213 ft**

Competitors cranes:

- *Liebherr: 245 EC-H 12 LITRONIC*
- *Wolffkran: 6531.12*
- *Terex: CTT231 12*

MR415

197 ft jib = 26,250 lb; Slewing ring (pivot) = **26,500 lb**

Max Height Under Hook = **197 ft**

Competitors cranes:

- *Liebherr: 355 HC-L 12/24 LITRONIC*
- *Wolffkran: 355B*
- *Terex: CTL400*



GMK 5275 - Features



- MEGATRAK™ Independent Suspension



- All-Wheel Steer



- MEGATRAK™ Top Steered



- Steer By Wire



- EKS 5 / EKS 5 Light

- ECOS



- MEGAFORM™



- TWIN-LOCK™



- Hydraulic Luffing Jib



- Tilting Superstructure Cab



- New Carrier Cabin (wide)



Suspension technology: Grove patented MEGATRAK™

MEGATRAK™ is Grove's patented independent suspension and all-wheel steer System. Each wheel is able to remain on the ground at all times, so that stresses and weight are not continually transferred between axles.

RIGID AXLE



Traditional suspension systems may raise the body of the crane, but do not increase ground clearance.

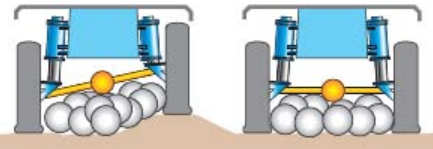

MEGATRAK™ does, as the differential is attached to the base of the carrier, offering a ground clearance up to 600 mm.

MEGATRAK™

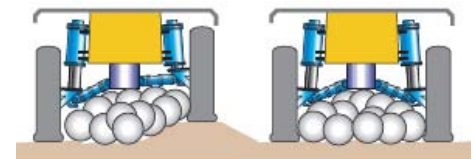

Suspension can be raised or lowered (both front/back and side to side by +6.3"/-4.7" [+160/-120 mm]) directly from the carrier cab and automatically leveled for road travel. **MEGATRAK™** also allows the use of a deeper carrier cross section, which improves the overall torsion strength of the crane.

Suspension technology: Grove patented **MEGATRAK™**

However, **MEGATRAK™** is not just about a comfortable and confident ride. The use of independent struts reduces the weight of the suspension system. These features make Grove all-terrains the strongest cranes available, with optimum lift characteristics.

Reduced maintenance:

- **Reliable suspension system.**
- **Same suspension on almost all models.**
- **Driveline remains aligned all the time.**
- **Steering linkage is protected (positioned directly under the chassis).**



GMK Features - MEGATRAK™

Top Steered

The latest design of MEGATRAK™ steering technology with top steered MEGATRAK™ cylinders allows a deeper cross-section of the frame for greater strength. This technology is used on GMK 5225, GMK 5275 and GMK 7550.

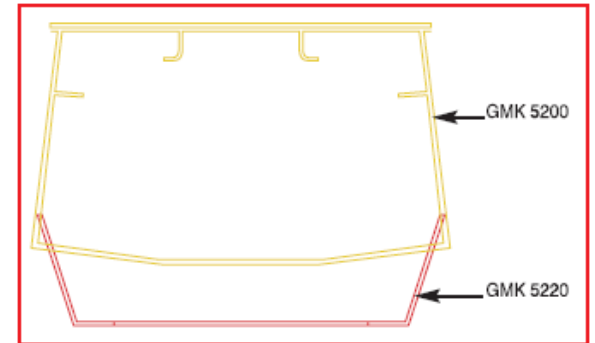

Megastruts with top steering

Megastruts with wishbones

steering rod

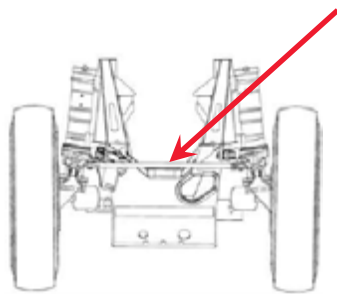

conventional

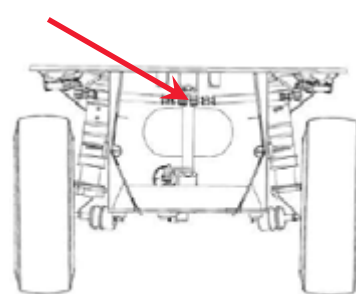

top steered

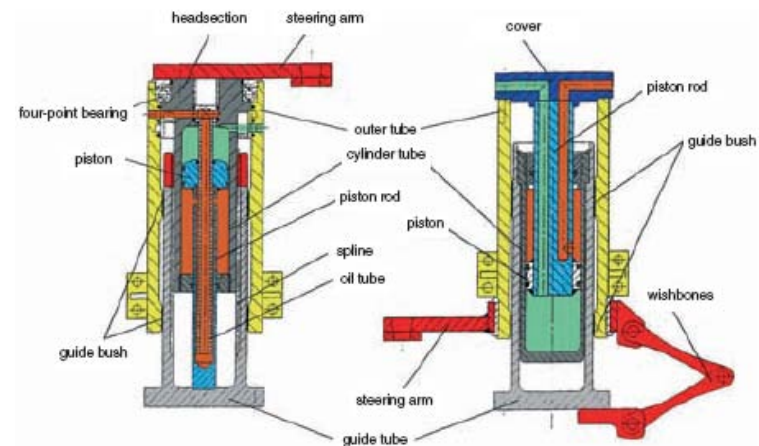

GMK Features - All-Wheel Steer

General

An easy to use all-wheel system gives the best steering on or off highway, eliminating tire scrub and stressed on non steering axles.

Exceptional manoeuvrability allows even the largest fully rigged GMK to get as close to the lift as possible.



Other systems, where one or more „dead weight“ hanging axles remain fixed – lead to higher axle loads, driveline maintenance problems, increased ground pressure and tire wall stress. All-wheel steer enables a fully laden crane to distribute weight evenly across all axles.

GMK Features - All-Wheel Steer

Steer By Wire



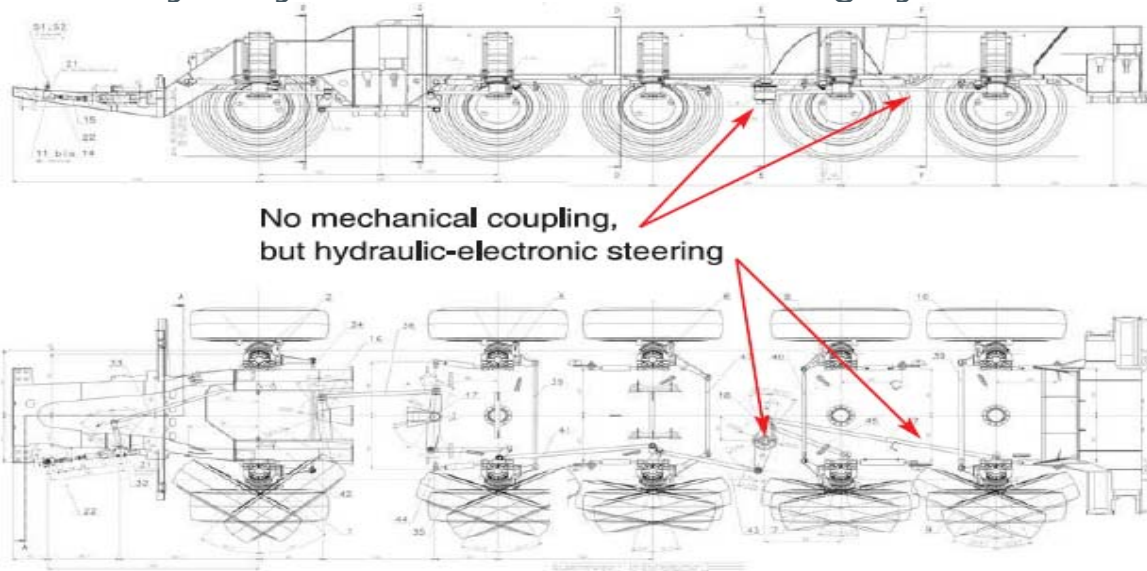

The rear 2 axles are steered by wire. Up to 12.5 mph [20 km/h] the 2 rear axles are steering depending on the driving mode (crab steer and minimum turning radius) and the speed in optimised angle. For highway travelling the 4th axle is fixed straight and up to 37 mph [60 km/h] axle 5 is steering in an optimised angle depending on the front axles and the speed. The conventional mechanical steering is replaced by a hydraulic-electronic steering system.



GMK Features - All-Wheel Steer Steer By Wire



ECOS controlled:

-  Highway travel mode
-  Crab steer mode
-  Minimum turning radius mode
-  Manual mode

The Advantages:

- Precise steering.
- Higher driving comfort.
- Reduced tyre wear.
- Economy of space by loss of the longitudinal push rods.
- More space for higher chassis.
- Weight reduction in spite of higher form stability.
- Reduction of costs by loss of the mechanical lock.
- Reduce of tire abrasion due to electronic controlled steering up to 60 km/h.
- Very convenient way of steering.



GMK Features - ECOS Superstructure

Electronic Crane Operating System

ECOS enables control of the entire crane's principle operations. Simple programming eases lift planning and a supply of essential information allows full concentration on the lift itself:

- Operating data on all crane functions.
- Constantly running data checks and data updates.
- Error code readouts.
- ECOS is run from three identical control boxes. Should unit malfunction, crane operation will revert to the functioning units.
- Although running separately ECOS also supplies any required information to the EKS Load Moment Indicator.



The Advantages:

- Telescoping mode automatic.
- Telescoping mode semi automatic.
- Operating data on power unit.
- Adjustment and readout of all operating speeds.
- Adjusts speeds automatically when jib extensions fitted.

GMK Features - ECOS Superstructure

Control and Monitor:

- Telescope, Boom Lift, Swing and Hoist
- Efficient, precise control with user friendly diagnostics
- Constant exchange of information with EKS but works independently

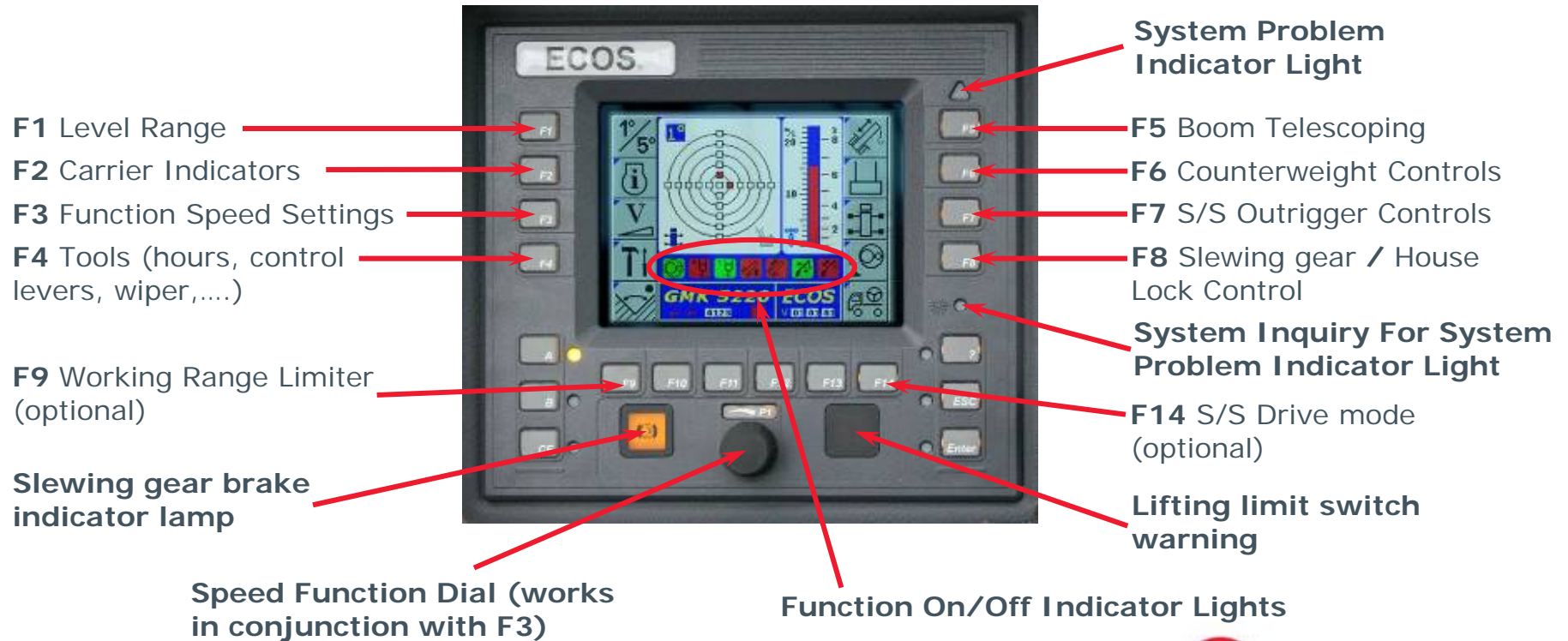

GMK Features - ECOS Carrier

Latest models feature ECOS also for the carrier functions. The ECOS screen is integrated in the carrier functions, diagnostics, warnings and error codes.



Carrier operations such as suspension and MEGATRAK™ controls, differentials and steering modes will be controlled via ECOS as well. The functions can be operated via the screen which replaces the switches usually installed in the middle console of the carrier cab.

GMK Features - ECOS Carrier



Grove Manitowoc National Crane Potain



GMK Features - EKS 5

Full Graphic Display

Monitoring the lifting condition of the crane at all times EKS works together with, but independently of the ECOS as a complete command and control system or separately as load moment indicator.



The EKS 5 features in addition to the Light version a full graphic display:

- Rear lightning.
- Graphic of boom telescoping %
- Shows loadcharts.
- Allows selection of loadchart sections.

Continually running fault analysis, the system advises service codes which can be transmitted to any Crane Care centre, world-wide, allowing fast accurate investigation and recommendation.

GMK Features - EKS 5

Full Graphic Display

Main Screen

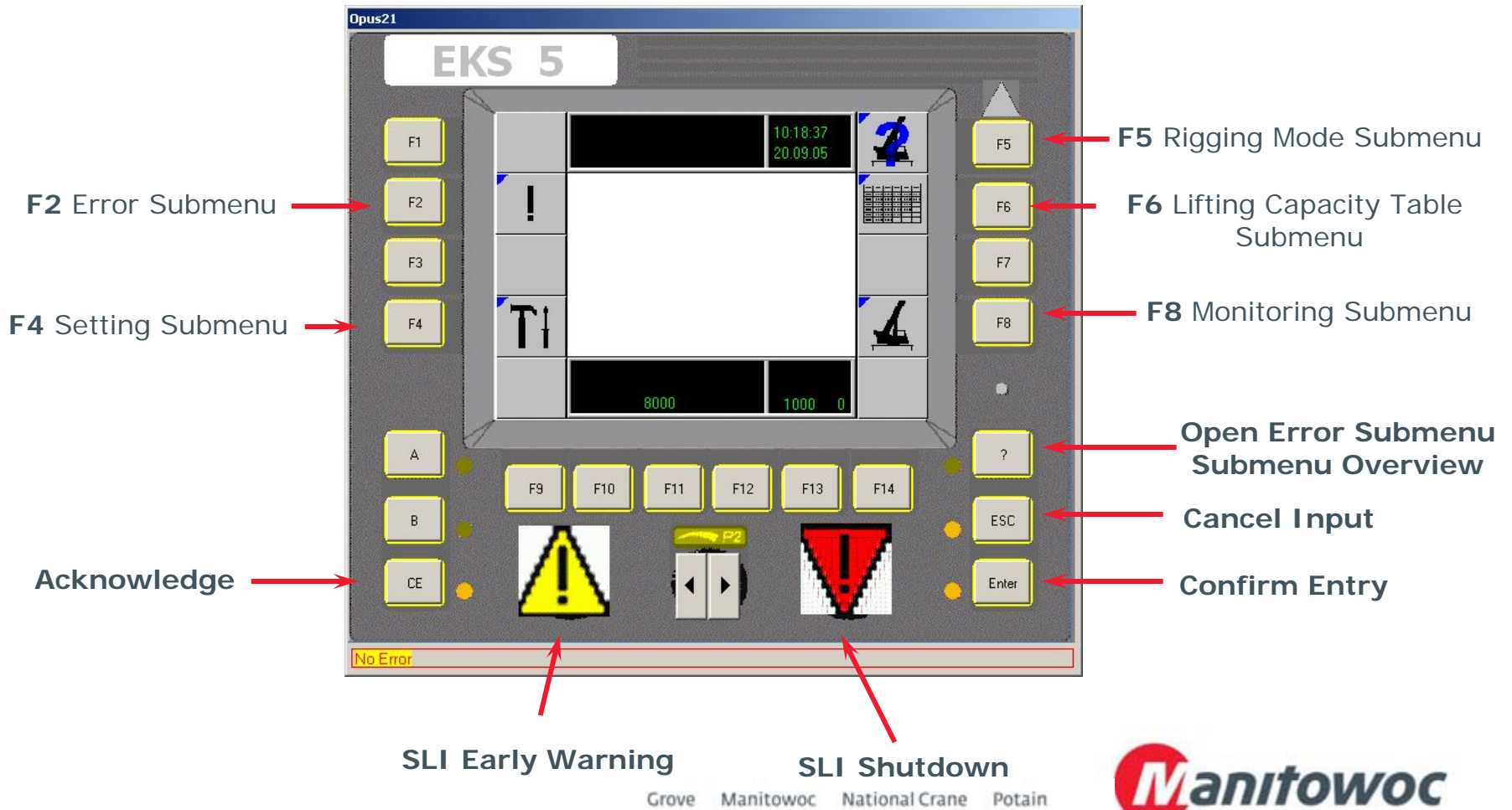

GMK Features - EKS 5

Full Graphic Display

Rigging Screen

The screenshot shows the 'Rigging Screen' for the EKS 5 crane. The screen displays various parameters and controls:

- Top Left:** 'Opus21' and 'EKS 5'.
- Top Center:** A large display showing '77,0 t' (current load) and '95,2 t' (t_{max}, maximum load).
- Top Right:** Up and down arrow buttons.
- Middle Left:** 'F1 Counterweight', 'F2 Outrigger Span' (8,90 m), 'F3 Slewing Range' (180,0°), 'F4 Reeving' (10,0), and 'SLI Code' (2200,0).
- Middle Right:** 'F5 & F6 Selection', 'F7 Boom System', and 'F8 MWL' (0,0 m).
- Bottom Left:** 'A', 'B', and 'CE Acknowledge' buttons.
- Bottom Center:** 'F9', 'F10', 'F11', 'F12', 'F13', and 'F14' buttons, along with a yellow warning triangle and a red warning triangle.
- Bottom Right:** '? Open Error Submenu', 'ESC Cancel Input', and 'Enter Confirm Entry' buttons.
- Bottom Bar:** 'No Error' status indicator.

GMK Features - EKS 5

Full Graphic Display

Working Screen

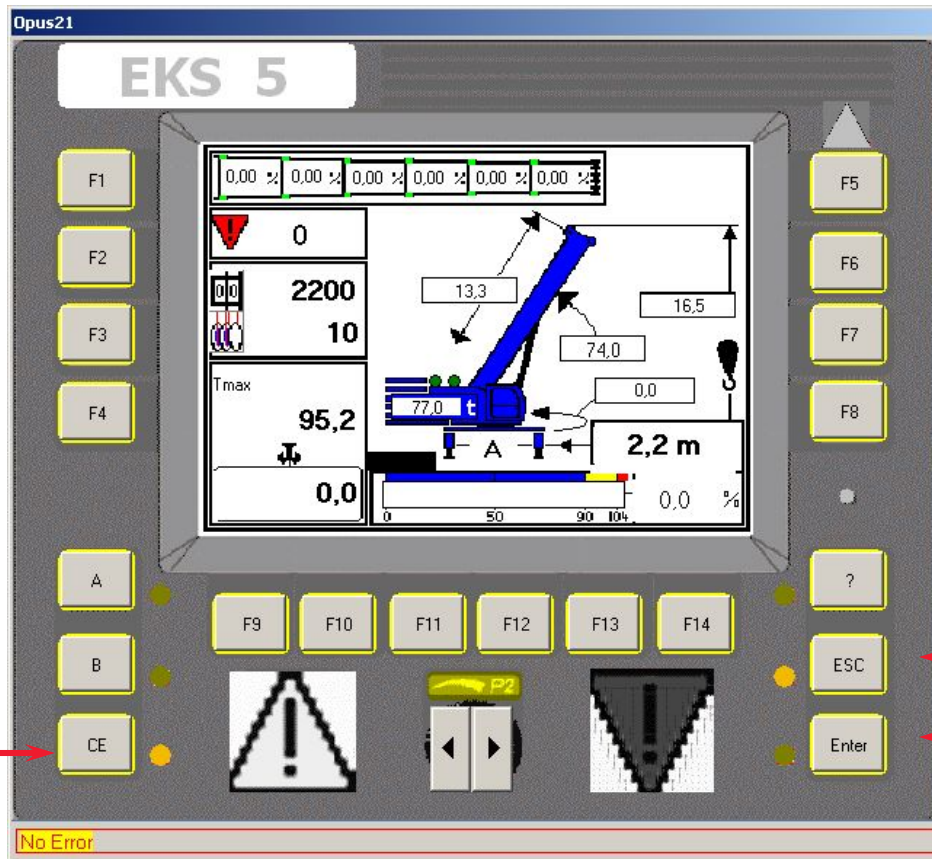

Acknowledge



Cancel Input



Confirm Entry



GMK Features - EKS 5

Full Graphic Display

Load Chart Screen

The screenshot shows the 'EKS 5' Load Chart Screen. The central display area contains a table of load capacity data and a vertical bar chart. The table data is as follows:

0.0	150.0
4.0	150.0
5.0	127.0
6.0	110.0
7.0	96.0
8.0	85.0
9.0	76.0
10.0	67.5
10.1	54.5
-0.1	0.0
-0.1	-0.1
-0.1	-0.1
-0.1	-0.1
3.0	-0.1

Annotations and button functions:

- F5 & F6 Scroll:** Red arrows point to the F5 and F6 buttons on the right side of the screen.
- Open Error Submenu Submenu Overview:** A red arrow points to the '?' button on the right side.
- Cancel Input:** A red arrow points to the ESC button on the right side.
- Confirm Entry:** A red arrow points to the Enter button on the right side.
- Acknowledge:** A red arrow points to the CE button on the left side.

At the bottom of the screen, there is a status bar that reads 'No Error'.

GMK Features - EKS 5

Full Graphic Display

Error Screen

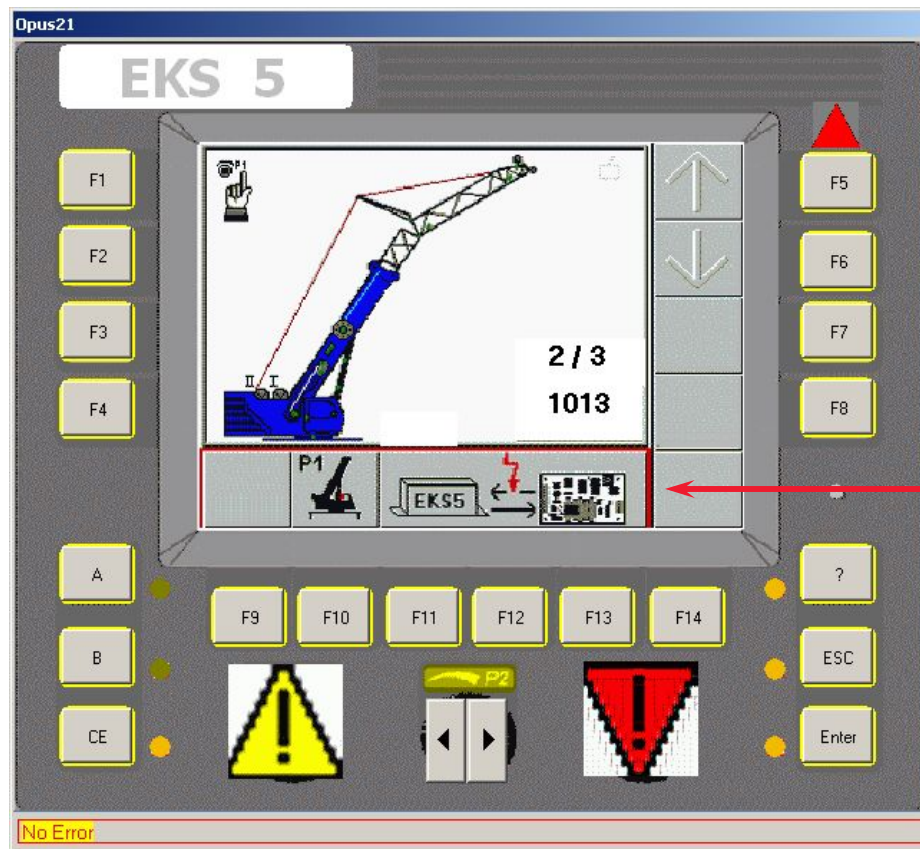

Error Definition

Boom technology: Grove patented TWIN-LOCK™

TWIN-LOCK™ is a fully hydraulic system with electronic controls. It features a single telescopic cylinder that used **two horizontally-mounted pins** to move a boom section into the required position. The use of two pins **increases security** and their position in the side of the boom means they operate in the neutral zone. The use of a single telescope cylinder **reduces weight** used elsewhere to strengthen the crane, and increases lifting capacity.

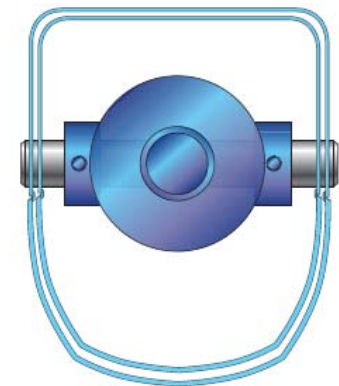

GMK Features – Hydraulic Jibs

Hydraulic Luffing Jib

Grove hydraulic jibs can be offset to luff under load from 0° - 40°. The hydraulic luffing jib is controlled from the operator cab and can be used with any boom and jib configuration.

The Movement is continually monitored by the EKS system, for maximum safety.



These jibs can also be conveniently stowed alongside the boom for secure road travel.

GMK Features - Cabs

Tilting Superstructure Cab

GROVE's 20° hydraulic tilting superstructure cab gives the operator an improved and more comfortable view of the lift.



Improved lift and operator performance – better views and increased comfort means lifts are completed quicker and accurately.

Increased view of the lift 0° - 20° tilt capability gives better views.

GMK Features - Cabs

Tilting Superstructure Cab



- Aluminum construction
- Opening windshield and rear window
- Sunscreen and sun visor



- Electronic dual axis crane controls
- Hot water heater (on 2 engine cranes)
- Engine independent diesel air heater (on single engine cranes)
- Adjustable seat
- Ergonomically arranged instrumentation



GMK Features - Cabs

Tilting Superstructure Cab



ECOS EKS 5 Light



Left:

- Swing brake
- Auxiliary hoist
- Cab tilt



Right:

- Main hoist
- Telescope
- Lift
- Luffing Swingaway

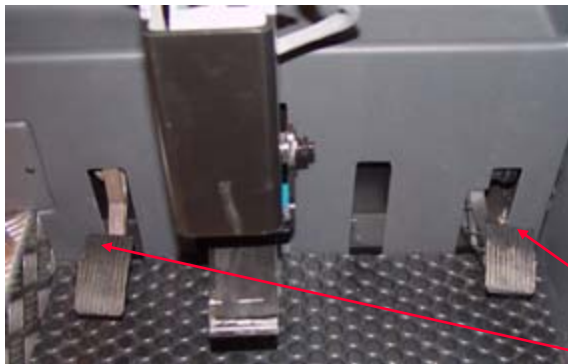

Throttle pedal
Swing brake pedal

GMK6350L - Positioning

GMK6250-L



GMK6350



GMK6350L - Positioning Overview



GMK6250-L



250 USt



236 ft



365 ft



GMK 6350L



350 USt



263 ft



367 ft



GMK6350



350 USt



197 ft



397 ft

GMK6350L - Positioning

Load charts vs. GMK6250-L

GMK6350L vs. GMK6250-L

- 28.8% better chart and 27 ft longer boom compared to GMK6250L:
 - New design (high strength steel)
 - More counterweight



→ GMK6350L is a new generation of long boom 6 axle cranes

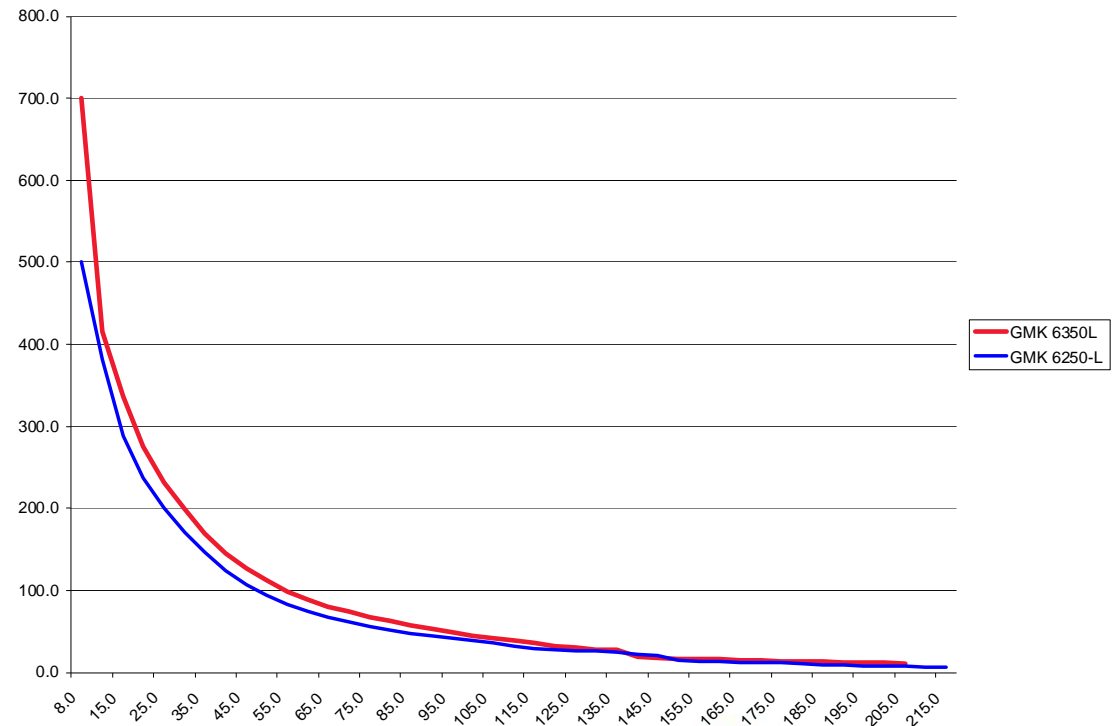

Grove Maniowoc National Crane Potain



GMK6350L - Positioning

Load charts vs. GMK6350

GMK6350L vs. GMK6350

- 13.9% better chart for GMK 6350 with a 67 ft shorter boom:
 - New design (high strength steel)
 - Less counterweight



→ GMK6350L is close to the charts of the GMK6350 by offering a 25% longer boom

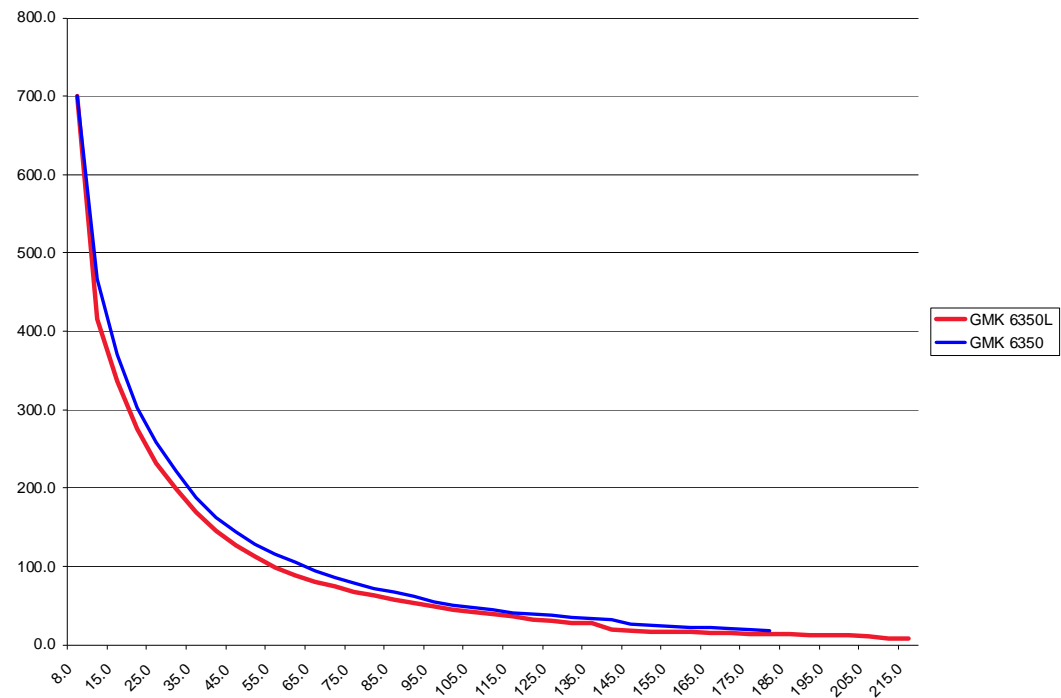

GMK6350L - Positioning Summary

The GMK6350-L sets a new benchmark in the long boom 6 axle segment. Higher performance was achieved by following innovations and design changes:

- Top steered MEGATRAK™ & Steer by Wire: more capacity due to weight savings in carrier design
- New design with optimized and latest state-of-the-art Megaform boom shape
- Use of high strength 160KSI [1100 n/mm²] steel
- More counterweight







GMK6350L

Grove Mobile Crane Options

GMK6350L Optional equipment Superstructure

B002T Boom / attachments

39 ft to 69 ft [12 m to 21 m] bi-fold swingaway, hydraulically offset from 5° to 40° including testing, calibration of LMI and load charts.

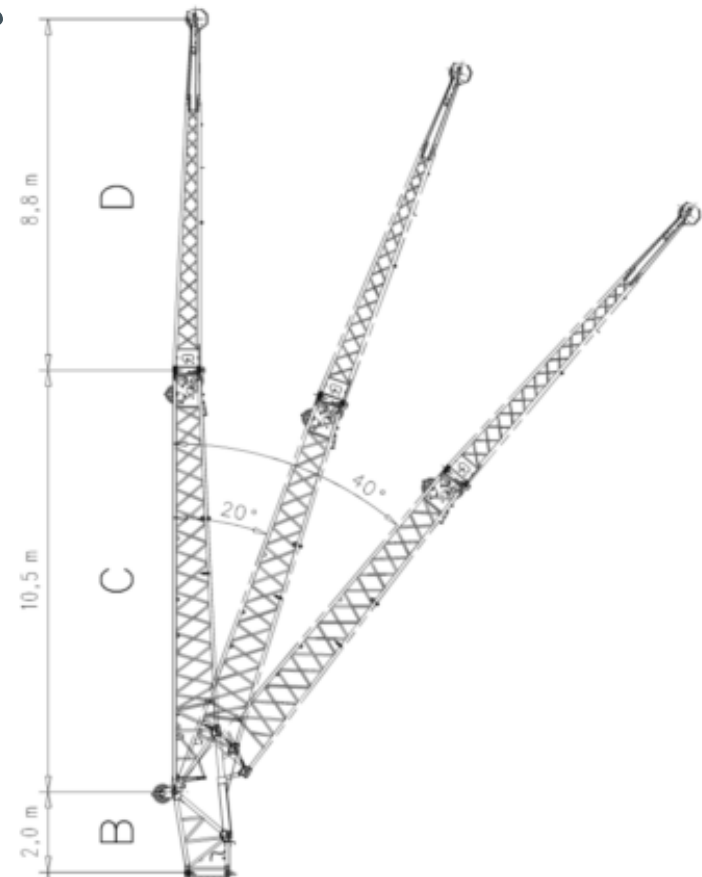

GMK6350L Optional equipment Superstructure

B003T Boom / attachments

95 ft [29 m] offsettable jib consisting of 69 ft [21 m] bi-fold swingaway and 1 x 26 ft [8 m] intermediate section. Bi-fold swingaway hydraulically offset from 5° to 40° including testing, calibration of LMI and loadcharts.

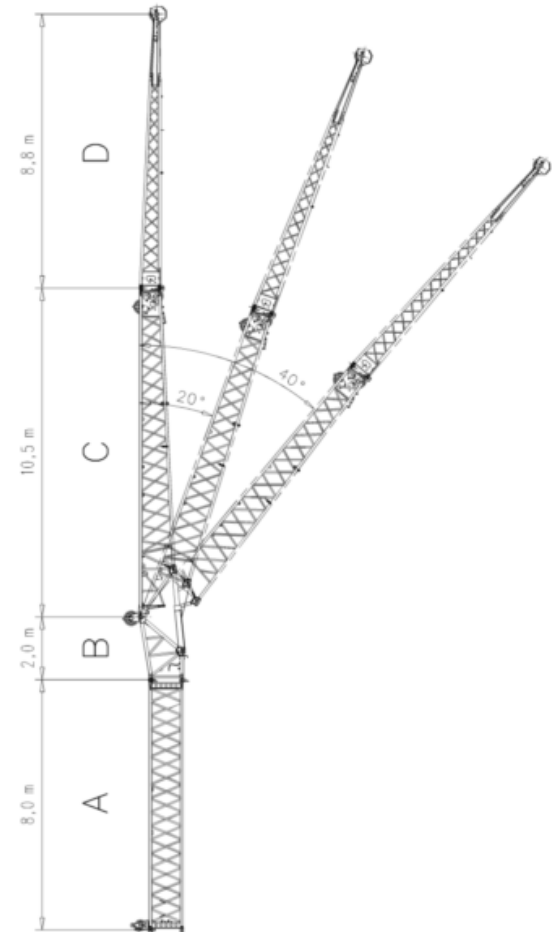

GMK6350L Optional equipment Superstructure

L004T Boom / attachments

2 worklights, mounted on top of boom base section (controlled from superstructure cab)

Halogen lamp, 70 Watt power lights can be adjusted from operators cab (tilt 120°).



GMK6350L Optional equipment Superstructure

L005T Boom / attachments

Boom head mounted aircraft warning light (certified/permanent).

When the crane operates near airports a warning light on boom head is required:

LED technology (red light); no service required (> 50.000 hours life); small dimensions (4"x2.5" [103x64 mm]); very little power needed; controlled from operator cab and fully wired.

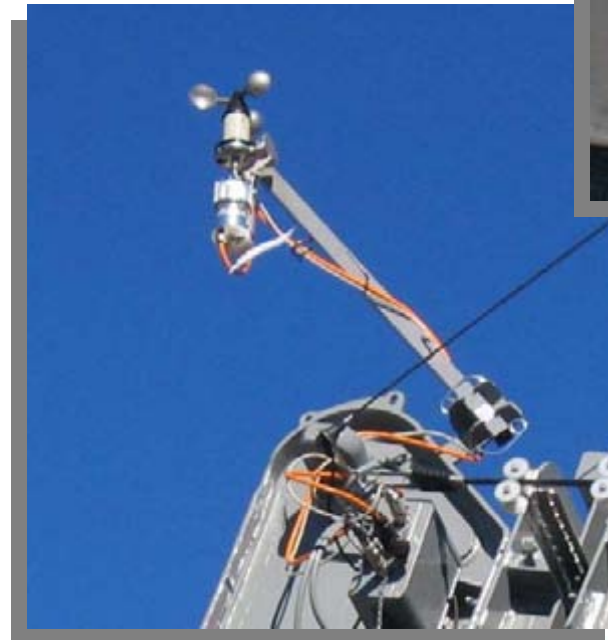

GMK6350L Optional equipment Superstructure

B006T Boom / attachments

7.5 ft [2.3 m] side stowed stub jib 83,000 lb [38 t] maximum capacity with 2 sheaves using 4 parts of line, offset 8° and 30° including testing, calibration of LMI and loadcharts.



GMK6350L STANDARD* equipment

Superstructure

B007T Boom / attachments

Auxiliary boom nose.

Auxiliary boom nose is used with the wire rope from the auxiliary hoist.

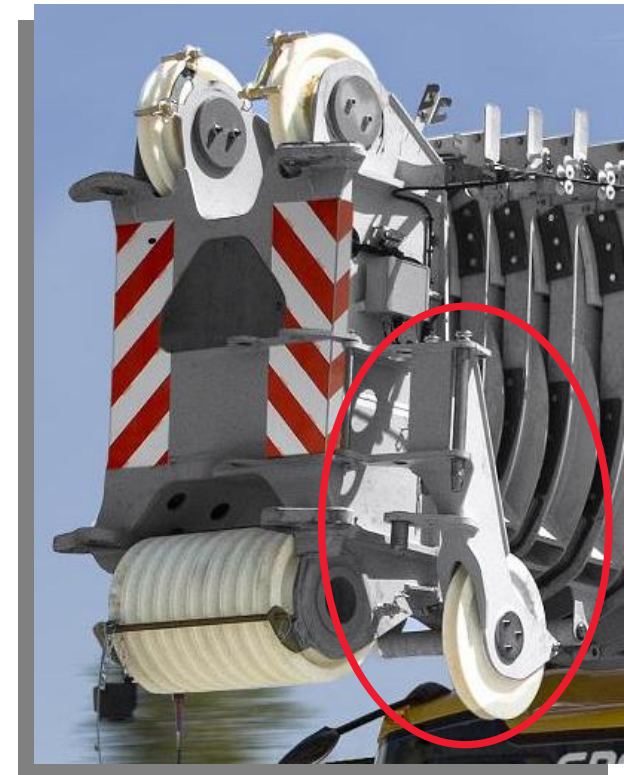

GMK6350L Optional equipment Superstructure

B008T Boom / attachments

Camera boom head.

- auto focus function
- nitrogen-gas filled housing
- waterproofed
- equipped with built-in night vision function

Video is wireless transmitted to a receiver and shown on an LCD display mounted in the superstructure cab.



GMK6350L STANDARD* equipment

Superstructure

T009T Boom / attachments

Trailing boom float kit.

This option consists of a kit that gives the possibility having the boom in floating position, rotating the superstructure 180° back and fixing the boom on a dolly. The slew drives and the elevating cylinder allow the boom to move while driving.

This option is especially for North American and Australian customers where lower axle loads need to be achieved.

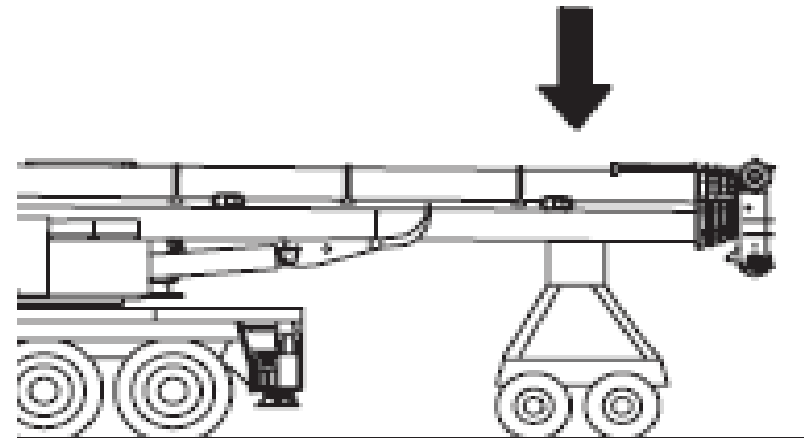

GMK6350L Optional equipment Superstructure

T010T Boom / attachments

Trailing boom boost weight transfer kit - retracting force.
(Includes boom float kit)

Pressure regulation through accumulator to increase boom weight on the dolly, relieve load on rear axles and increase load on front axles.

Required force need to be stated when ordered!

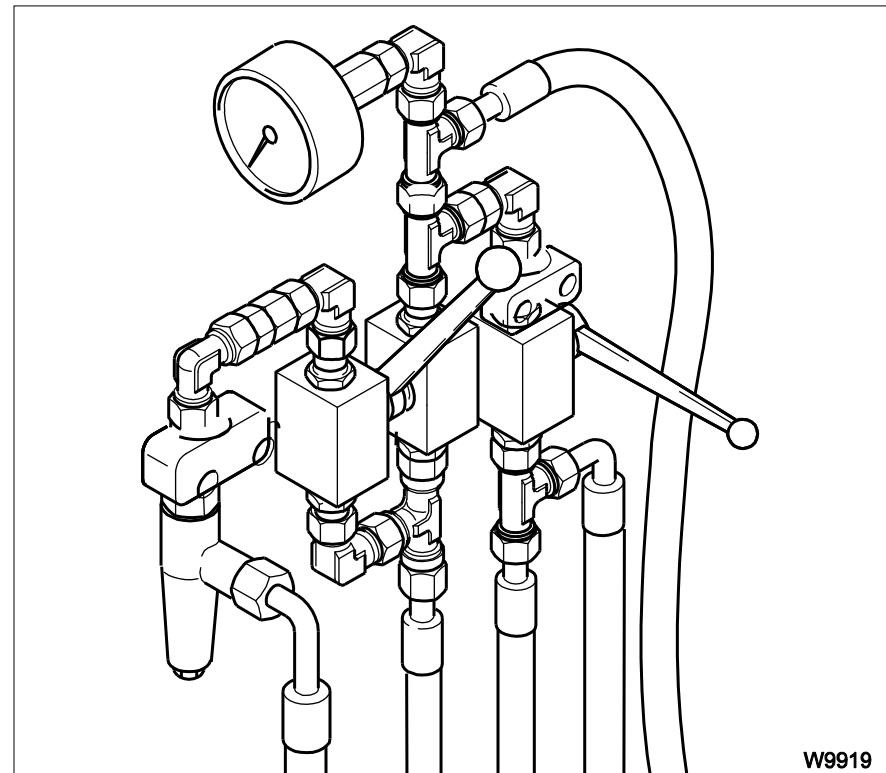

GMK6350L STANDARD* equipment

Superstructure

T011T Boom / attachments

Boom removal kit.

This option allows to remove the main boom and to transport it with an auxiliary trailer; boom removal kit consists of: cylinder support (1), fixing belt (2), bottle jack for the elevating cylinder (3) and lifting slings for the boom (4).

Hydraulic disconnects, hydraulic boom pivot pins and a hydraulic pin to remove the elevating cylinder are provided on the boom.

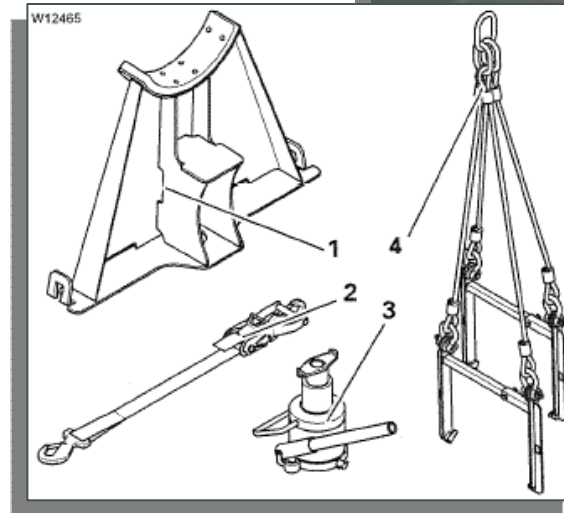
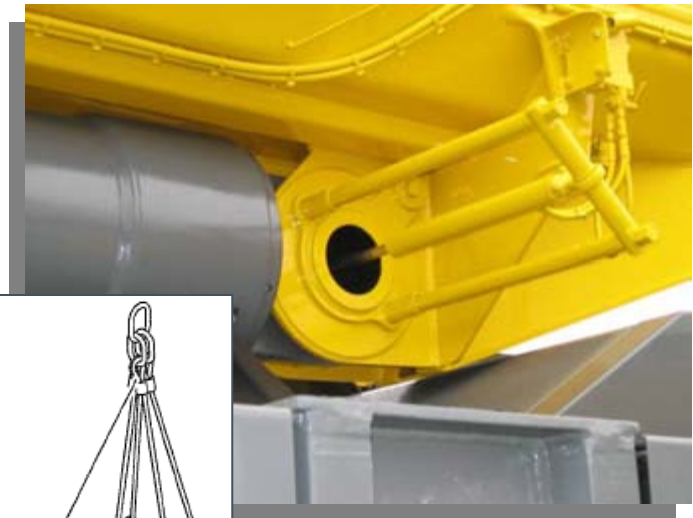

Grove Maniowoc National Crane Potain



GMK6350L STANDARD* equipment

Superstructure

D012T Hoist / Hydraulic

Auxiliary hoist, self rigging with counterweight, axial piston motor with planetary gear and automatic multiple disc brake. Drum rotation indicator, 1148 ft [350 m] of 22mm wire rope. Including second upper boom head sheave, hoist camera and working light.

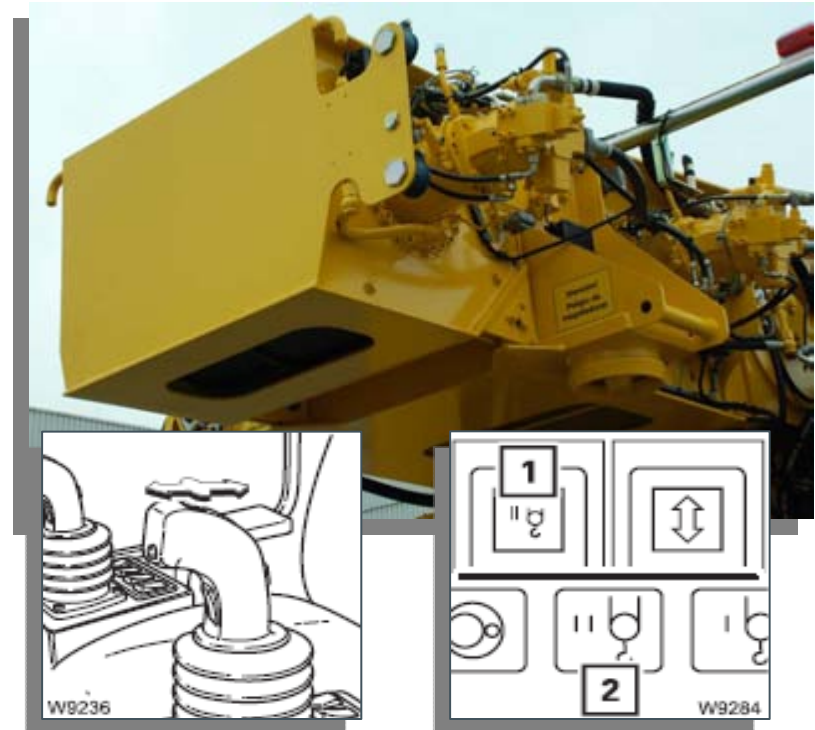

When the auxiliary hoist is activated (switching on button 1), the indicator lamp (2) in the main menu of the crane control display lights green. It is possible to lift or lower the load using left joystick. There is a hoist drum synchro that will notice an impulse when the hoist drum rotates.

GMK6350L STANDARD* equipment Superstructure

J013T Hoist / Hydraulic

Additional oil cooler for hydraulic system.

On every GMK model a standard oil cooler is mounted on the superstructure, the second oil cooler is optional. The additional oil cooler provides better oil cooling and is suggested for hot weather countries or if the crane is equipped with an auxiliary hoist.



GMK6350L Optional equipment Superstructure

Hook blocks (US)

Item	Lifting Capacity	Sheaves	Weight	Parts of line	Possible load with crane
F74	200 ton	9	5,660	1-18/19*	378,360 / 399,380 lb*
F67	165 ton	7	3,851	1-15	315,300 lb
F21	125 ton	5	3,732	1-11	231,220 lb
F17	80 ton	3	2,127	1-7	147,140 lb
F98	35 ton	1	1,398	1-3	63,060 lb
F64	Ball 19 ton	-	1,202	1	21,020 lb

* requires additional boom nose sheave

GMK6350L Optional equipment Superstructure

C020T Cab Options

Engine independent diesel cab heater (air) with 24h timer

This cab heater is independent from carrier and superstructure engines and it is **diesel propelled**; can be used also to pre-heat superstructure engine. It is equipped with a standard 24 hour timer.

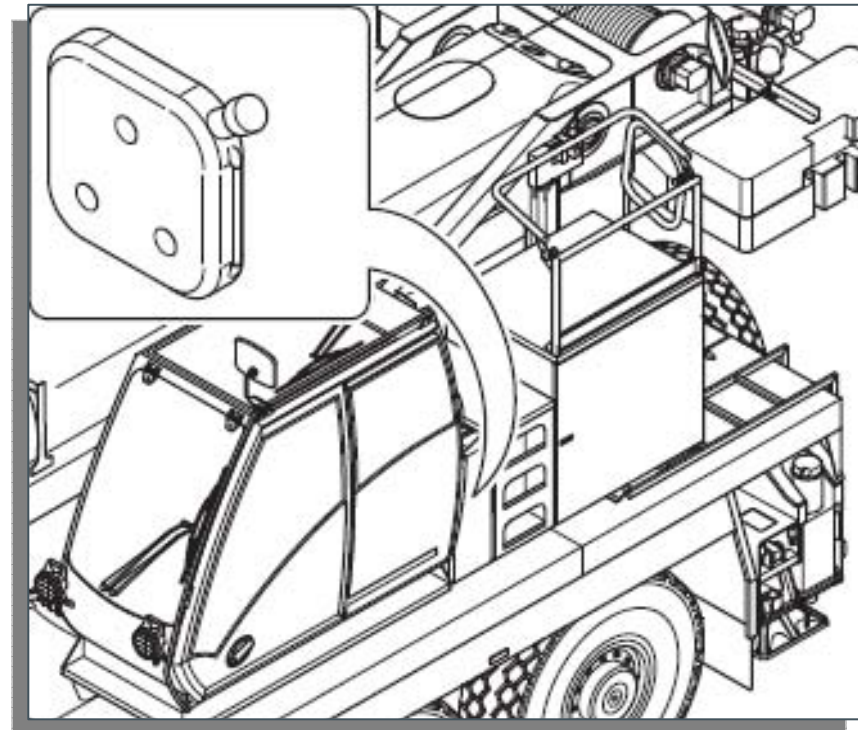

GMK6350L Optional equipment Superstructure

C021T Cab Options

Air conditioning.

All components of the air conditioning system are located on the superstructure, beside the engine.



GMK6350L STANDARD* equipment Superstructure

H022T Counterweight

Additional 83,800 lb [38 t]
counterweight consisting of
2 x 19,840 lb [9 t] and 2 x
22,050 lb [10 t] removable
wing weights.

Includes testing calibration
and load charts.

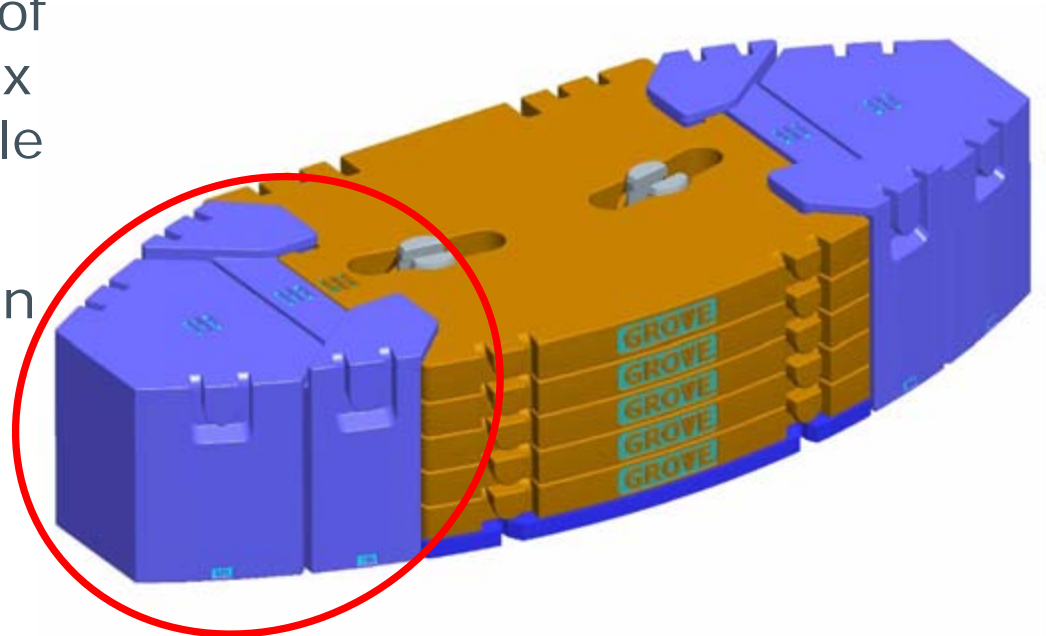

GMK6350L Optional equipment

Carrier

E030T Powerplant / Accessories

Engine Shutdown Valves (for both engines)

This option consists of a valve on the exhaust manifold (both engines) that stops air intake when the engine rpm exceeds a certain limit (due to explosive gas intake). In this case a warning light flashes on ECOS display.

Engine shutdown valve is requested when crane should work in special workplaces (especially in chemical plants and refineries).

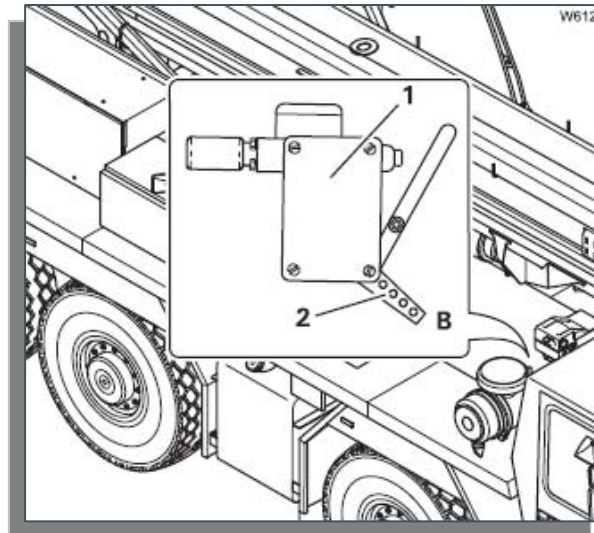

Lever 2 in position B is signalling that control device is on.

Lever 2 in position A, control device is off; lever 1 allows manual starting of control device.

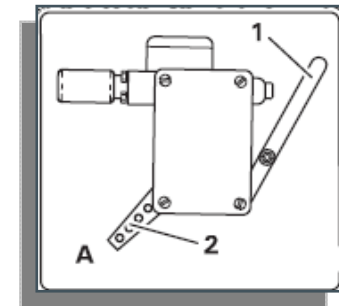

GMK6350L STANDARD* equipment

Carrier

G031T Tyres and Wheels

Twelve 16.00 R25 (445/95 R25) on / off highway radial tyres in lieu of standard.

Note:

Carrier width 9.8 ft [2975 mm]
Crane height 13.1 ft [4000 mm]



GMK6350L Optional equipment Carrier

31T Tyres and Wheels

Twelve 14.00 R25 (385/95 R25) on / off highway radial tyres in lieu of US standard.

Note:

Carrier width 9.8 ft [2975 mm]
Crane height 13.0 ft [3950 mm]



GMK6350L Optional equipment Carrier

G032T Tyres and Wheels

Twelve 16.00 R25 (445/95 R25) on / off highway radial tyres on aluminum rims.

Note:

Carrier width 9.8 ft [2975 mm]
Crane height 13.1 ft [4000 mm]



GMK6350L Optional equipment Carrier

G033T Tyres and Wheels

Twelve 20.5R25 (525/80 R25)
on / off highway radial tyres in
lieu of standard.

Note:

Carrier width 10.1 ft [3070 mm]
Crane height 13.1 ft [4000 mm]



GMK6350L Optional equipment Carrier

G034T Tyres and Wheels

Twelve 20.5R25 (525/80 R25)
on / off highway radial tyres on
aluminum rims.

Note:

Carrier width 10.1 ft [3070 mm]
Crane height 13.1 ft [4000 mm]



GMK6350L Optional equipment Carrier

G035T Tyres and Wheels

14.00R25 (385/95 R25)
spare wheel.



GMK6350L Optional equipment Carrier

G036T Tyres and Wheels

16.00R25 (445/95 R25)
spare wheel.



GMK6350L Optional equipment Carrier

G037T Tyres and Wheels

16.00R25 (445/95 R25)
spare wheel (aluminum).



GMK6350L Optional equipment Carrier

G038T Tyres and Wheels

20.5R25 (525/80 R25)
spare wheel.



GMK6350L Optional equipment Carrier

G039T Tyres and Wheels

20.5R25 (525/80 R25)
spare wheel (aluminum).



GMK6350L Optional equipment Carrier

G040T Tyres and Wheels

Stowage for spare wheel. (Not in combination with K074T, K067T, P044T or P045T)

Note: spare wheel can not be mounted in combination with rear storage box for rigging equipment, trailer hitch or removable rear outrigger box.



GMK6350L Optional equipment

Carrier

K041T Carrier Accessories

12 x 8 x 12 drive in lieu of standard.

Includes an additional driven axle (axle 6).

Crane standard drive: 12 x 6 x 12 (3 driven axles on axle 1, 4 and 5).

Driven axles



GMK6350L Optional equipment Carrier

K042T Carrier Accessories

Hydraulic retarder integrated in gear box.

The hydraulic retarder slows down the crane preserving the standard brake system. The efficiency is comparable to electric retarder (Telma), but in this case braking power is provided by viscous friction of the oil, that internally flows between rotor and fixed vanes. Can be activated with a hand lever that is located on right side of the dashboard.



GMK6350L Optional equipment

Carrier

K043T Carrier Accessories

Outrigger length control.

Outrigger length is directly transmitted to ECOS/EKS.

No manual input necessary.

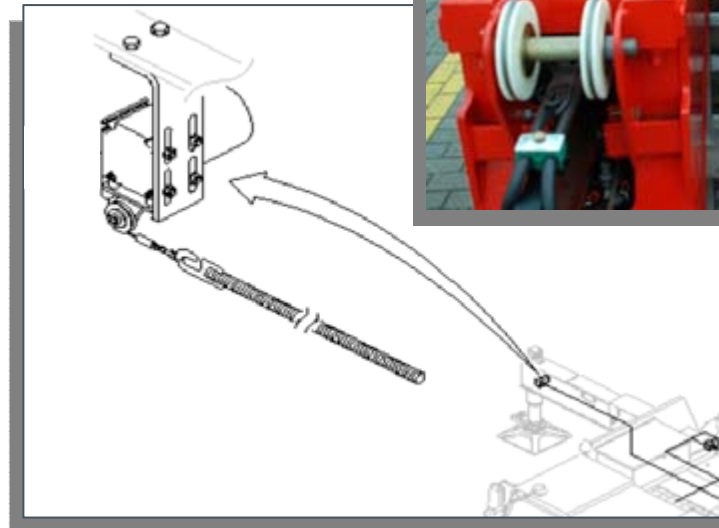
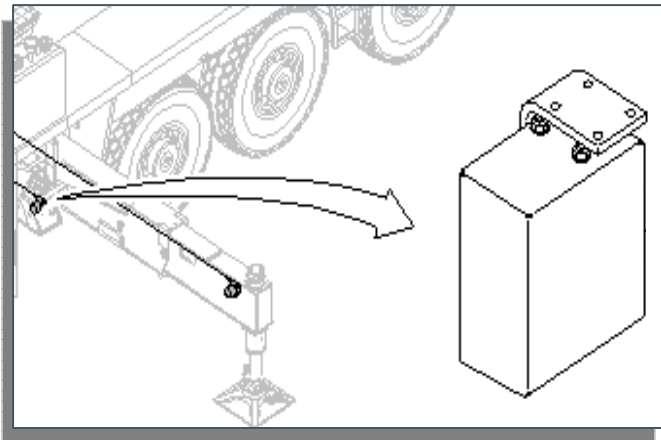

GMK6350L Optional equipment Carrier

P044T Carrier Accessories

Trailer hitch including brakes and lights [50mm coupling 193 kN drawbar value].

Transmission of braking and lights signals is included (ABS, air, electrical and hydraulic).

50 mm coupling \Rightarrow 193 kN drawbar value

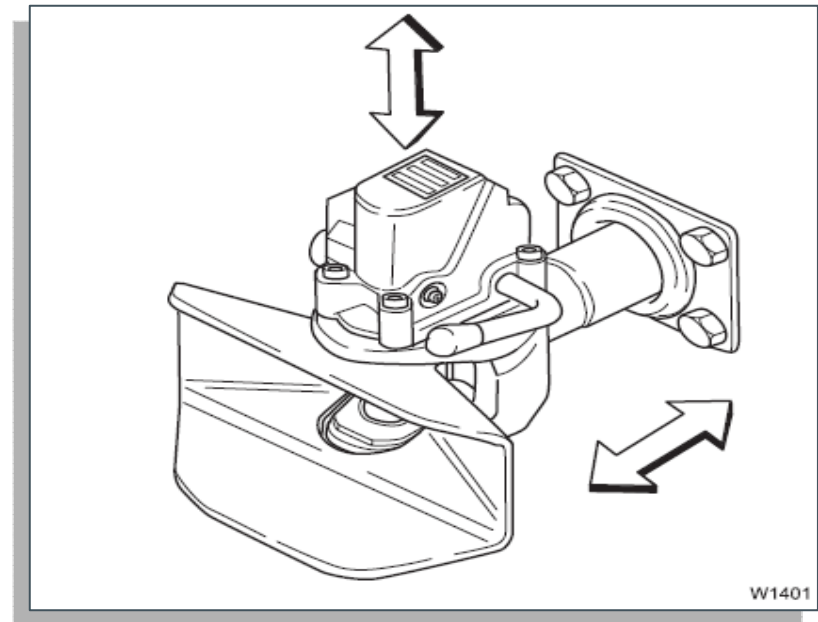

GMK6350L Optional equipment Carrier

P045T Carrier Accessories

Towing hitch, rear mounted
[100 kN towing capacity].

This option consists of a towing
hitch without brakes and
electrical sockets.



GMK6350L STANDARD* equipment

Carrier

K046T Carrier Accessories

Hydraulic disconnect for all outrigger beams.

Hydraulic connections allow the disconnect of all hydraulic hoses that provide outrigger movements. Outrigger beams can be removed in order to reduce crane weight.



GMK6350L STANDARD* equipment Carrier

J047T Carrier Accessories

Additional oil cooler for carrier hydraulic system.

max. cooling power,
useful in hot
weather areas

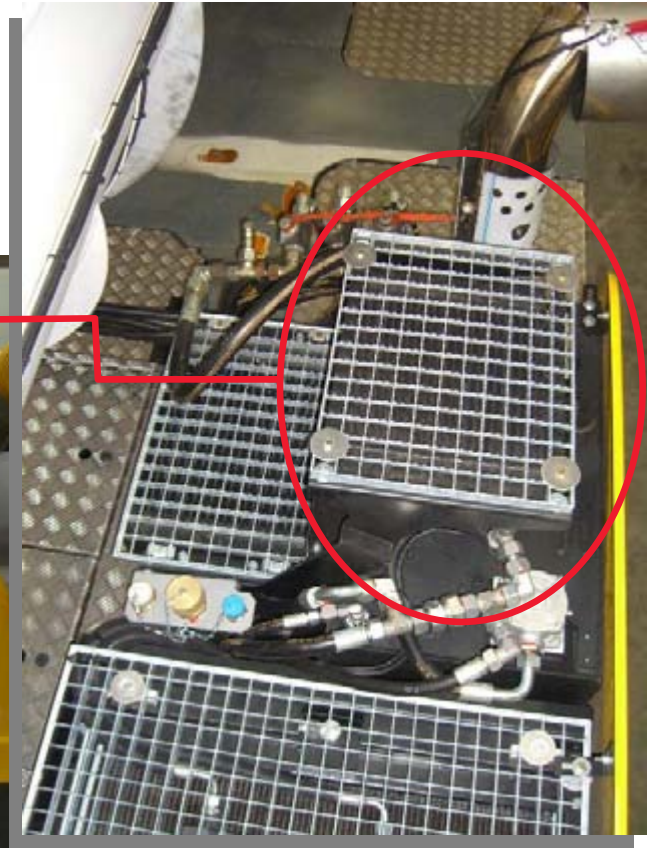

GMK6350L Optional equipment Carrier

M048T Cab Accessories

Engine independent diesel cab heater (water) with 24h timer

The diesel cab heater (Webasto), mounted under carrier cab, is independent from carrier engine and it is diesel propelled by main fuel tank. Can be used also to pre-heat carrier engine and equipped with a 24 hour timer.



GMK6350L Optional equipment Carrier

M049T Cab Accessories

Hinged Bunk Bed mounted
inside the carrier cab.

When not in use the bed can be closed and
fixed to the cab's rear side.



GMK6350L Optional equipment Carrier

K051T Cab Accessories

Additional spotlights on rear side of carrier for reversing.

- high light intensity
- unbreakable and waterproof lens
- resistant to heavy jolts



GMK6350L Optional equipment Carrier

N060F Miscellaneous

Non-standard paint finish, two colours, same grade as standard.



GMK6350L Optional equipment Carrier

N061F Miscellaneous

Non-standard paint finish, three colours, same grade as standard.



GMK6350L Optional equipment

Carrier

N064F Miscellaneous

Sign writing on basic boom section, turntable panelling and driver's cab.



GMK6350L Optional equipment Carrier

C065T Miscellaneous

Wireless remote control for all crane functions (Hetronic).

Depending on crane equipment the following crane function can be controlled:

- engine start/stop
- constant engine speed
- main/auxiliary hoist
- slewing gear
- telescopic mechanism
- lowering extensions



The crane can be operated within the range of the remote control without being on site

GMK6350L Optional equipment

Carrier

S066T Miscellaneous

Datalogger on superstructure.

This software tool records up to 370 hours operation and specifically all following datas:

- Nominal and actual load
- Radius
- Height
- Reeving
- Rigging code

All recorded lifting datas are downloaded on memory card to PC (256 Mb)

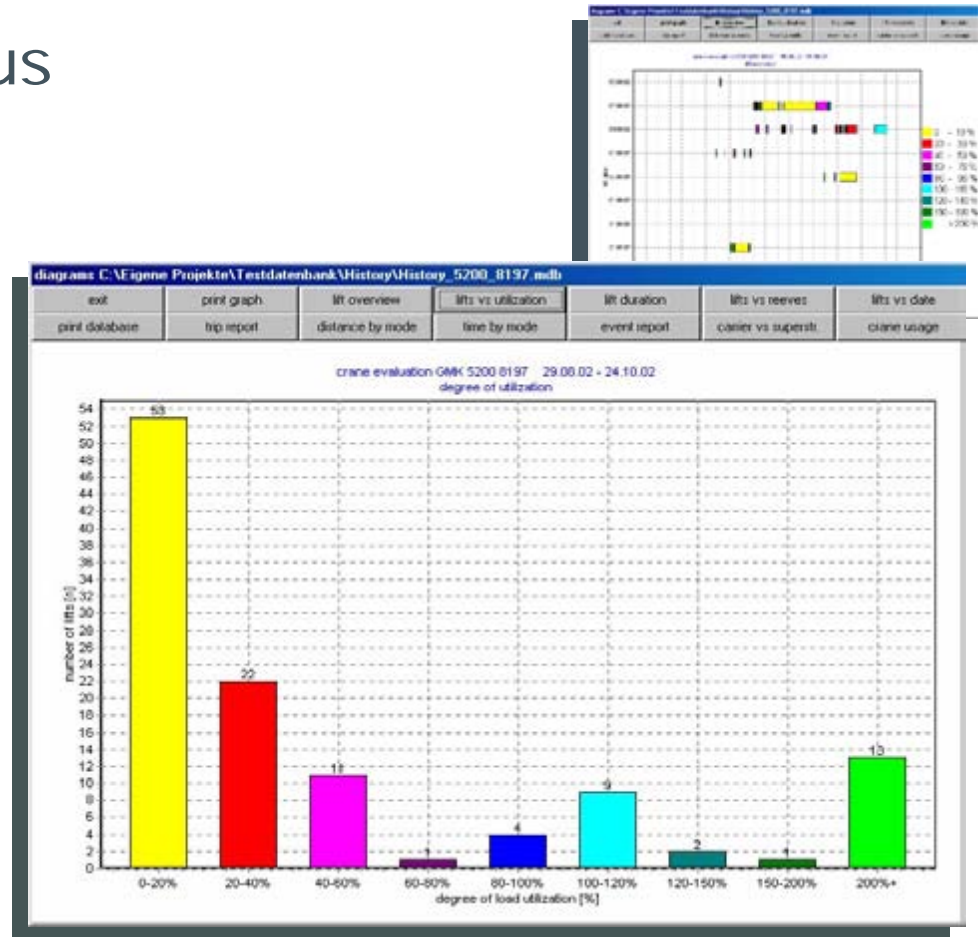

GMK6350L Optional equipment Carrier

K067T Miscellaneous

Rear Mounted Stowage
Box for Rigging Equipment
(9 ft [2.75 m] wide)

(Not in combination with
G040T).



GMK6350L Optional equipment Carrier

C068T Miscellaneous

NYC house lock
(360° swing lock).

The houselock consists of a lockable, form-fitting locking unit, which is installed on two slewing gears between the slewing motor and the slewing gear transmission. As a result, the superstructure can be locked at any angle within the entire slewing range.

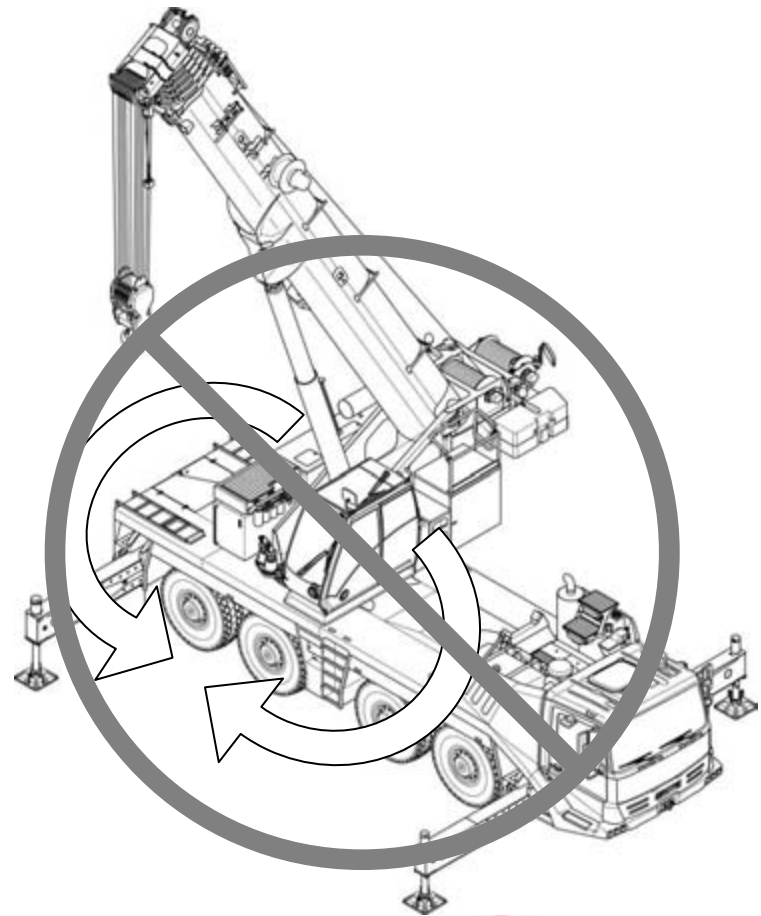

GMK6350L Optional equipment

Carrier

C069T Miscellaneous

Emergency operation with transformer (BGR 159).

For an emergency operation connect the transformer(2) to the carrier hydraulic(1) and superstructure hydraulic(4). With the levers(3) it is possible to handle crane functions. The transformer ensures that the oil circuits stay separated.

This option is a European requirement for personal lifting.

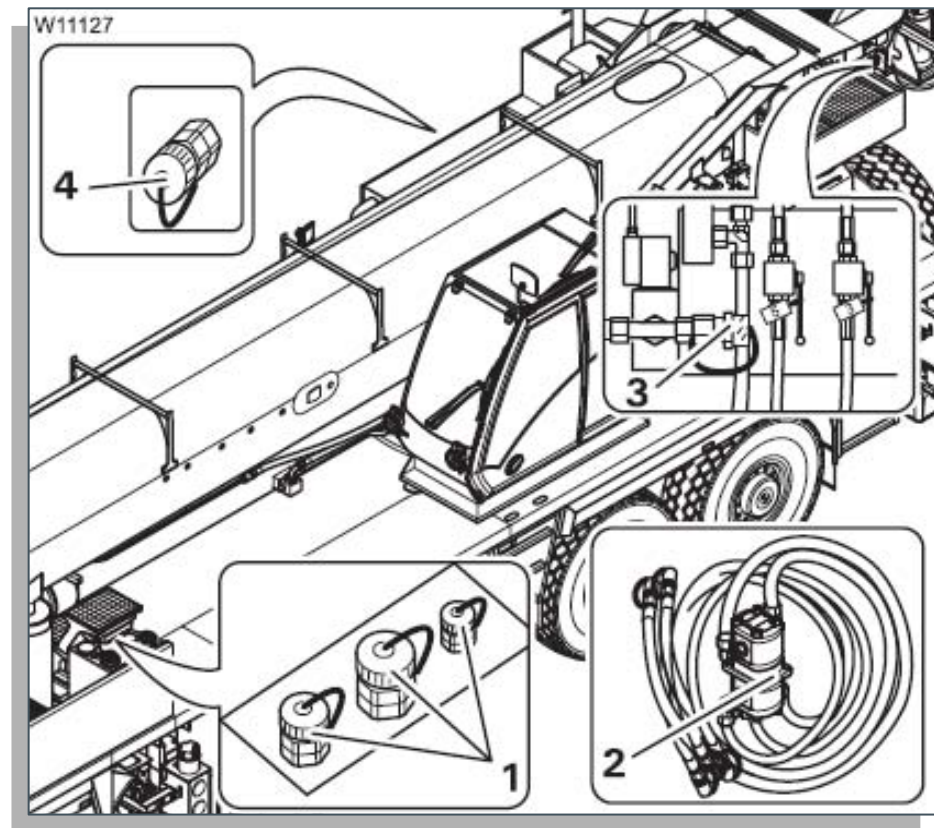

GMK6350L Optional equipment Carrier

C070T Miscellaneous

Emergency operation
without transformer
(BGR 159).

hose connection on
carrier

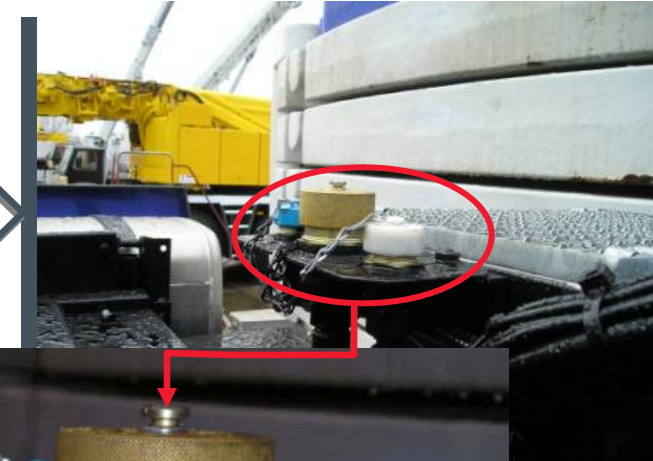

levers for
emergency
operation on
superstructure



GMK6350L Optional equipment Carrier

R071T Miscellaneous

-30° package

This equipment is intended for special use (temperature around -30°C) and includes:

- Engine preheating system (via engine independent warm water heater)
- Battery preheating
- Cold weather batteries
- Arctic oil (viscosity 32 cSt)
- Flame start kit for both engines (air intake preheating)



GMK6350L Optional equipment Carrier

S072T Miscellaneous

External starting outlet
(carrier and superstructure)

Bridges a discharged battery without
disassembling any parts of the
vehicle.



GMK6350L Optional equipment Carrier

R080T Miscellaneous

Homologation kit - to comply with national regulation and registration codes.







Technical Description

GMK6350L

January 2010 / Revision A

GROVE

GMK6350L

Technical Description (provisional)

GROVE TELESCOPIC ALL-TERRAIN CRANE TYPE GMK6300L

Max. lifting capacity: 700,000 lb @ 8 ft over rear with special equipment.

ITEM NO.

A001T BASIC STANDARD UNIT

SUPERSTRUCTURE	Connected to the carrier by a ball bearing slewing ring and HSFG bolts. Continuous 360° rotation.	
Turntable	Torsion-resistant welded construction in high tensile close grain steel plate.	
Engine	Make:	Mercedes-Benz
	Model:	OM 926 LA
	Type:	4-stroke Diesel direct fuel injection
	Coolant:	Water circulation cooling
	Cylinders:	6 (R)
	Rating:	210 kW (286 HP) at 2200 min ⁻¹
	Torque:	1120 Nm (826 ft/lb) at 1400 min ⁻¹
	Emission:	EUROMOT 3 / EPA / CARB (non road)
	Fuel tank:	approx. 79 gal
Hydraulic system	1 axial piston pump with load sensing. 1 double gear pump for slewing gear. Power limiting control via ECOS. Oil coolers. Tank capacity: 317 gal	

GMK6350L

Technical Description (provisional)

Control system	<p>ECOS electronic crane control. All crane movements infinitely variable by electronic-hydraulic pilot control. Through armrest-integrated crane control levers with automatic reset to zero.</p>										
Main and aux. hoist	<p>Axial piston motor (variable displacement) with planetary gear and automatic multiple disk brake.</p> <table><tr><td>Single line pull max.:</td><td>21,020 lb</td></tr><tr><td>Single line speed max.:</td><td>417 fpm</td></tr><tr><td>Drum diameter:</td><td>18 inch</td></tr><tr><td>Rope diameter:</td><td>0.87 inch</td></tr><tr><td>Rope length:</td><td>1148 ft</td></tr></table> <p>Drum rotation indicator.</p> <p>Hoist cameras incl. light.</p>	Single line pull max.:	21,020 lb	Single line speed max.:	417 fpm	Drum diameter:	18 inch	Rope diameter:	0.87 inch	Rope length:	1148 ft
Single line pull max.:	21,020 lb										
Single line speed max.:	417 fpm										
Drum diameter:	18 inch										
Rope diameter:	0.87 inch										
Rope length:	1148 ft										
Derricking	<p>1 cylinder. Boom angle from $-1,5^{\circ}$ to $+83^{\circ}$. Derricking time: approx. 95 sec.</p>										
Slewing gear	<p>3 slewing gears, axial piston motors, planetary gear;</p> <p>Dynamic brake: hydrostatic, operated by control lever.</p> <p>Parking brake: 1 automatic multiple disk brake. Hand-operated switch to release slewing drive (to center boom).</p> <p>Slewing speed infinitely variable approx. $0 - 1,3 \text{ min}^{-1}$ by means of control lever. The maximum slewing speed ($1,3 \text{ min}^{-1}$) can be reduced to a min. speed by preselection, which allows very smooth slewing motions.</p>										

GMK6350L

Technical Description (provisional)

Telescopic boom	<p>7 section welded structure made of high tensile close grain steel. Boom length: 51 – 163 ft. Boom head with 9 sheaves. Auxiliary boom nose. New boom shape MEGAFORM (incl. base section).</p> <p>Hydraulic extension. Telescopic time: 760 sec.</p> <p>Telescoping load depends on hydraulic pressure, boom angle and boom lubrication. Telescopic system TWIN-LOCK consists of a single stage cylinder with integrated locking system. Manual and automatic operation possible. Trailing boom float kit and boom removal kit.</p>				
Operator's cab	<p>New Style Full vision 20° tilt aluminium cab, mounted on left-hand side of turntable, safety glass windows, hinged front window with windshield wiper, tilting window in cab rear, sunvisor and window shade, dormer window pane with wiper, engine dependent hot water heater, fan and defroster nozzles. Adjustable, flexible seat with armrest and headrest, cab lighting, two spot lights, stereo radio/ CD player, fire extinguisher 6kg.</p> <p>ECOS system including: Engine data, speed adjustment, boom telescoping, counterweight rigging, ourtrigger controls, warning systems.</p>				
Electric system	<table><tr><td>Three-phase generator:</td><td>28 V / 80 A</td></tr><tr><td>2 batteries:</td><td>12 V / 170 Ah</td></tr></table> <p>Instrument panel: Base material consisting of recyclable hard foam material. Modular design, easy to fit owing to plug and socket connections.</p>	Three-phase generator:	28 V / 80 A	2 batteries:	12 V / 170 Ah
Three-phase generator:	28 V / 80 A				
2 batteries:	12 V / 170 Ah				
Safety installations	<p>Electronic safe load indicator EKS 5 with automatic cut-out and full graphic display for actual and admissible load, radius, telescoping and various working conditions, userfriendly, illuminated display. Hoist and lowering limit switches, pipe break safety valves, pressure relief valves, wind speed indicator. Working range limiter.</p>				

GMK6350L

Technical Description (provisional)

Counterweight	203,900 lb tonnes with standard unit. Roadable with 0 tonnes. Up to 36,400 lb technically roadable, restrictions applying. Tailswing max. 18 ft.
Central lubrication	for boom and lift cylinder heel pin, ball bearing slewing ring and main hoist bearing.
Remote Control	Cable connected remote control unit for swingaway erection, control of outriggers and emergency control of crane functions.
Paint finish	Grove standard livery.

CARRIER

Chassis	Special 6-axle carrier, all-welded torsion-resistant large cross section box-type in high tensile close grain steel plate.
Engine	Make: Mercedes-Benz Model: OM 502 LA Type: 4-stroke Diesel direct fuel injection Coolant: Water circulation cooling Cylinders: 8 (90°-V) Rating: 405 kW (551 HP) at 1800 min ⁻¹ Torque: 2600 Nm (1918 ft/lb) at 1300 min ⁻¹ Filter: Heavy-duty air cleaner Emission: EUROMOT / EPA / CARB (non road) Fuel tank: 132 gal (integrated in superstructure)
Transmission	Allison automatic transmission 4500 SP with 6 forward and 1 reverse gear. Transfer case Kessler VG 2600, 2 speed, with interaxle differential lock.

GMK6350L

Technical Description (provisional)

Axle lines	<p>Drive 12 x 6 x 12</p> <p>1st axle line: drive + steer 2nd axle line: steer 3rd axle line: steer 4th axle line: drive + steer 5th axle line: drive + steer ("steer by wire") 6th axle line: steer ("steer by wire")</p> <p>A driven axle line consists of 2 wheels with integrated planetary hub reduction and a center-mounted differential gearing.</p>
Transverse differential locks	<p>Integrated in all center-mounted differential gearings including air shift cylinder.</p>
Interaxle differential locks	<p>With 12 x 6 integrated in the transfer case and the 4th axle line. With 12 x 8 (option) integrated in the transfer case, the 4th axle line and the 5th axle line in off-road gear.</p> <p>Control from the cab.</p>
Independent wheel Suspension MEGATRAK	<p>Hydropneumatic suspension, level regulation and hydraulic suspension lock-out. Suspension range: +6.7/-5.0 inch. Automatic suspension level control.</p> <p>Increase of ground clearance up to 6.7 inch by raising carrier and reducing headroom clearance by lowering carrier down by 5.0 inch. Combination possibilities for front, rear and side tilt.</p>
Steering	<p>ZF semi-integral dual-circuit hydraulic power-assisted steering, 2 steering cylinders per steered axle line. Automatic switch-in of a stand-by steering pump in case of main pump failure. Axles 1 and 2 are conventionally steered, axles 3 and 4 with speed depending steering (mechanically locked above 25 km/h), axles 5 and 6 are electronic-hydraulic steered ("steer by wire"). The steering modes „All-wheel steer“, „crab steer“ and „lowest radius“ are available. "Crab steer" and "lowest radius" only for jobsite travel.</p>

GMK6350L

Technical Description (provisional)

Central lubrication	Automatic interval-controlled lubrication of the entire steering system.
Tyres	12 x 445/95 R25 (16.00R25), single tyres.
Rims	25 - 11.00 / 1.7 for 16" tyres.
Brakes	<p>Service brake: Pneumatic dual-circuit brake, acting on all wheels. Drum brakes on all wheels (1st axle line with Duplex brake, 2nd to 6th axle line with Simplex brake). Single chamber air dryer with integrated pressure regulator.</p> <p>Permanent brake: Exhaust brake with fixed throttle.</p> <p>Parking brake: Pneumatically operated spring-loaded brake acting on 2nd, 4th, 5th and 6th axle line.</p> <p>Brake design in accordance with maximum loads, i.e. 26,500 lb axle load. Brake system complies with EC regulations.</p>
Driver's cab	<p>Composite designed aluminium and fibre reinforced plastic, two-man-design, suspended, safety glass windows, laminated frontwindscreen, windshield wiper, electric windshield washer, defroster nozzles for the front windscreen, lockable doors with electric power window, driver's seat with pneumatic adjustment and integrated safety belt, lumbar support, passenger's seat, engine-dependent hot water heater, heated rear view mirrors, electrically adjustable, stereo radio / CD player and trip recorder, fire extinguisher 6kg mounted inside the cab, two rotating beacons, air conditioning, reversing camera system.</p> <p>Operating instrumentation and devices: Suspension lock-out, suspension level control, drive connect and disconnect, differential locks, all-wheel steer by ECOS. Rear fog light.</p>

GMK6350L

Technical Description (provisional)

Informations :

Steering pumps, generator, direction indicator, main beam, parking brake, hazard warning light, rear fog light.
Tachograph, odometer air pressure gauge for both brake circuits.

ECOS screen for:

fuel gauge, temperature gauge for the engine and transmission circuit, engine coolant, suspension lock-out, air filter, hydraulic filter, drive connect and disconnect, operating hour meter, oil pressure gauge for engine.

Hydraulic system 2 axial piston variable displacement pumps for outriggers, steering, and axle suspension.
1 gear pump for fan drive.
1 radial piston pump for emergency stand by steering.
Oil tank with micro oil filters.
Oil cooler.

Outriggers 4 double hydraulically telescoping beams, synchronized with vertical cylinders and outrigger pads. Independent horizontal and vertical movement control on each side of the chassis.
Worklight for each outrigger beam. Outrigger pad load indicator with read out on carrier and superstructure.

Outrigger spread: length: 28.5 ft.
width: 27.9 ft fully extended.

Additional load chart for: 24.3 / 20.7 / 16.4 / 9.8 ft.

Electronic crane level indicator. Removable rear outrigger box and hydraulic disconnect for front outrigger beams.

Electric system Three-phase generator: 28 V / 100 A.
2 batteries: 12 V / 170 Ah.

Lights and signals 24 V, rear fog light, reversing light, halogen spot light, 4 rotating beacons.

Instrument panel:

Base material consisting of recyclable hard foam material.
Modular design, easy to fit owing to plug and socket connections.

GMK6350L

Technical Description (provisional)

Towing hitch front mounted, 100 kN towing capacity.

Tools 1 set of tools.

Paint finish GROVE standard livery.

PERFORMANCE Travelling speeds: max. 53 mph
(with 14", 16" and 20.5" tyres)

Gradeability: 49 % (with 14" tyres)
43 % (with 16" and 20.5" tyres)

Turning radii: 46.8 ft at corner of main boom.
44.7 ft at corner of cab.

DIMENSIONS Basic unit in travelling position:

Length: 57.7 ft
50.4 ft (carrier)

Width: 9.8 ft (with 14" and 16" tyres)
10.1 ft (with 20.5" tyres)

Height: 13.0 ft (with 14" tyres)
13.1 ft (with 16" and 20.5" tyres) (without auxiliary hoist)
+6.7 ft / -5.0 ft

WEIGHT ON-ROAD 158,800 lb

GMK6350L

Technical Description (provisional)

OPTIONAL EQUIPMENT

SUPERSTRUCTURE

BOOM / ATTACHMENTS

B002T	39 ft to 69 ft bi-fold swingaway, hydraulically offset from 5° to 40° including testing, calibration of LMI and load charts.
B003T	95 ft offsettable jib consisting of 69 ft bi-fold swingaway and 1 x 26 ft intermediate section. Bi-fold swingaway hydraulically offset from 5° to 40°. Including testing, calibration of LMI and loadcharts.
L004T	2 worklights, mounted on top of boom base section (controlled from superstructure cab).
L005T	Boom head mounted aircraft warning light (registered).
B006T	7.5 ft side stowed stub jib [83,000 lb tonnes max capacity] using 4 parts of line. Offset 8° and 30° including testing, calibration of LMI and loadcharts.
B007T	Auxiliary boom nose.
B008T	Camera boom head.
T009T	Trailing boom float kit.
T010T	Trailing boom boost weight transfer kit - retracting force (including boom float kit). (Please indicate required force)
T011T	Boom removal kit.

HOISTS / HYDRAULIC

D012T	Auxiliary hoist, self rigging with counterweight, axial piston motor with planetary gear and automatic multiple disc brake. Drum rotation indicator, 1148 ft of 0.87 inch wire rope. Including second upper head sheave on boom. Hoist camera and working light.
J013T	Additional oil cooler for hydraulic system.

HOOKBLOCKS / HEADACHE BALL

F74	200 ton, 9 sheave quick-reeving hookblock with European dead end, weight: 5,300 lbs.
F67	165 ton, 7 sheave quick-reeving hookblock with European dead end, weight: 3,851 lbs.
F21	125 ton, 5 sheave quick-reeving hookblock with European dead end, weight: 3,732 lbs.
F17	80 ton 3 sheave quick-reeving hookblock with European dead end, weight 2,127 lbs.
F98	35 ton, 1 sheave quick-reeving hookblock with European dead end, weight: 1,398 lbs.
	19 ton, single line top-swiveling headache ball, weight: 1,202 lbs.

GMK6350L

Technical Description (provisional)

F64

CAB OPTIONS

- C020T Engine independent diesel cab heater which also serves as engine preheater incl. 24h timer.
C021T Air conditioning.

COUNTERWEIGHT

- H022T Additional 83,776 lb counterweight consisting of 2 x 19,842 lb and 2 x 22,046 lb removable wing weights. Includes testing calibration and load charts.

OPTIONAL EQUIPMENT

CARRIER

POWERPLANT / ACCESSORIES

- E030T Engine Shutdown Valves (for both engines).

TYRES AND WHEELS

- G031T Twelve 16.00 R25 (445/95 R25) on/off highway radial tyres in lieu of standard.
G032T Twelve 16.00 R25 (445/95 R25) on/off highway radial tyres on aluminium rims, applicable on double coin tires only.
G033T Twelve 20.5R25 (525/80 R25) on/off highway radial tyres in lieu of standard.
G034T Twelve 20.5R25 (525/80 R25) on/off highway radial tyres on aluminium rims, applicable on double coin tires only.
31T Twelve 14.00R25 (385/95 R25) on / off highway radial tires in lieu of standard.
G035T 14.00R25 (385/95 R25) spare wheel.
G036T 16.00R25 (445/95 R25) spare wheel.
G037T 16.00R25 (445/95 R25) spare wheel (aluminium).
G038T 20.5R25 (525/80 R25) spare wheel.
G039T 20.5R25 (525/80 R25) spare wheel (aluminium).
G040T Stowage for spare wheel. **(Not in combination with K067T, P044T, P045T)**

CARRIER ACCESSORIES

- K041T 12 x 8 x 12 drive in lieu of standard.
K042T Hydraulic retarder integrated in gear box.
Outrigger length control.

GMK6350L

Technical Description (provisional)

K043T	
P044T	Trailer hitch including brakes and lights [50mm coupling 193 kN D-Value, DC=193 kN, V=60 kN] heavy.
P045T	Towing hitch, rear mounted [100 kN towing capacity].
K046T	Hydraulic disconnect for all outrigger beams.
J047T	Additional oil cooler for carrier hydraulic system.

CAB ACCESSORIES

M048T	Engine independent diesel cab heater which also serves as engine preheater incl. 24h timer.
M049T	Hinged Bunk Bed mounted inside the carrier cab.
K051T	Additional spotlights on rear side of carrier for reversing.

MISCELLANEOUS

N060T	Non-standard paint finish, two colours, same grade as standard.
N061T	Non-standard paint finish, three colours, same grade as standard.
N064T	Sign writing on basic boom section, turntable panelling and driver's cab.
C065T	Wireless remote control for all crane functions (Hetriconic)
S066T	Datalogger on superstructure
K067T	Rear Mounted Stowage Box for Rigging Equipment (2.75m wide) (Not in combination with G040T) .
C068T	NY house lock (360° swing lock).
C069T	Emergency operation with transformer (BGR 159).
C070T	Emergency operation without transformer (BGR 159).
R071T	-30° package incl. engine preheating system, battery preheating, cold weather batteries, arctic oil and flame start kit for carrier engine.
K072T	External starting outlet (carrier and superstructure).
K074T	Removable Outrigger Box.
R080T	Homologation kit - to comply with national regulation and registration codes.

– Subject to technical modifications –

This crane is designed for operation according to crane class A1 (as defined in ISO 4301-2). This is only a statement about design, but no warranty as defined in § 443 BGB (german civil code).

GMK Features

Product Management
July 2008



GMK Features Overview



▪ MEGATRAK™ Independent Suspension



▪ MEGATRAK™ Top Steered



▪ All-Wheel Steer



▪ Steer By Wire

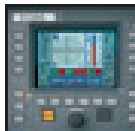

▪ ECOS



▪ EKS 5 / EKS 5 Light



▪ MEGAFORM™



▪ TWIN-LOCK™



▪ Hydraulic Luffing Jib



▪ Integrated Heavy Duty Jib



▪ Tilting Superstructure Cab



▪ New Carrier Cab

GMK Features Overview

GMK Features available	GMK 7450 GMK 7550	GMK 6300 GMK 6350	GMK 6220-L GMK 6250-L	GMK 5220 GMK 5275	GMK 5170 GMK 5225	GMK 5130-2 GMK 5165-2	GMK 5110-1 GMK 5135	GMK 5095 GMK 5115	GMK 4100L GMK 4115L	GMK 4100 GMK 4115	GMK 4080-1 GMK 4100B	GMK 3055	GMK 3050-1	GMK 2035E
MEGATRAK	•	•	•	•	•	•	•	•	•	•	•	•	•	
Top Steered MEGATRAK	•			•	•						•			
All-Wheel Steer	•	•	•	•	•	•	•	•	•	•	•	•	•	•
Steer By Wire				•	•									
ECOS	•	•	•	•	•	•	•	•	•	•	•	•	•	•
Carrier ECOS				•	•	•	•	•	•	•				
EKS 5 Light		•	•	•	•	•	•	•	•	•	•	•	•	•
EKS 5	•			•	•	•	•	•	•	•				
MEGAFORM	•	•	•	•	•	•	•	•	•	•	•	•	•	
TWIN-LOCK	•	•	•	•	•	•	•	•	•	•	•	•		
Hydraulic Luffing Jib			•	•	•	•	•	•	•	•	•	•	•	•
Integrated Heavy Duty Jib					•	•	•	•	•	•				
New Carrier Cab Design						•	•	•	•	•				
Titiable Superstructure Cab	•	•	•	•	•	•	•	•	•	•	•	•	•	•

• Optional

MEGATRAK™

GMK Features - MEGATRAK™

Independent Suspension

MEGATRAK™ is GROVE's patented independent suspension and all-wheel steer System. Each wheel is able to remain on the ground at all times, so that stresses and weight are not continually transferred between axles.

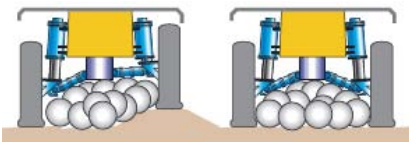

Traditional suspension systems may raise the body of the crane, but do not increase ground clearance.

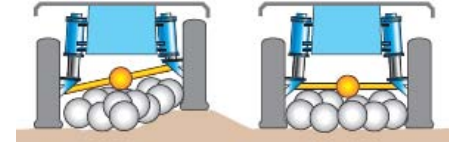

MEGATRAK™ does, as the differential is attached to the base of the carrier, offering a ground clearance up to 23.6" [600 mm]. Suspension can be raised 6.5" [170 mm] or lowered 5" [130 mm] (both front/back and side to side) directly from the carrier cab and automatically leveled for road travel. MEGATRAK™ also allows the use of a deeper carrier cross section, which improves the overall torsional strength of the crane.

MEGATRAK™



RIGID AXLE



GMK Features - MEGATRAK™

Independent Suspension

However, MEGATRAK™ is not just about a comfortable and confident ride. The use of independent struts reduces the weight of the suspension system. These features make Grove all-terrains the strongest cranes available, with optimum lift characteristics.

Once you`ve experienced MEGATRAK™ you`ll really appreciate the difference.



Reduced maintenance:

- Reliable suspension system.
- Same suspension on almost all models.
- Driveline remains aligned all the time.
- Steering linkage is protected (positioned directly under the chassi).
- Constant tire contact for equal tire wear.



GMK Features - MEGATRAK™ Top Steered

The latest design of MEGATRAK™ steering technology with top steered MEGATRAK™ cylinders allows a deeper cross-section of the frame for greater strength. This technology is used on GMK 5225, GMK 5275 and GMK 7550.

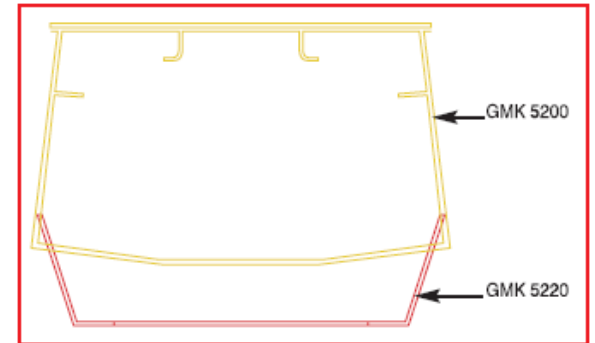

Megastruts with top steering

Megastruts with wishbones

steering rod

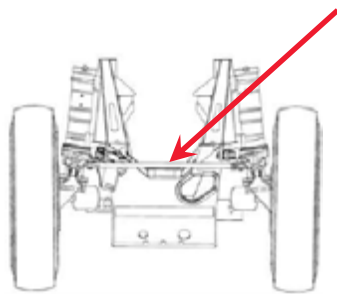

conventional

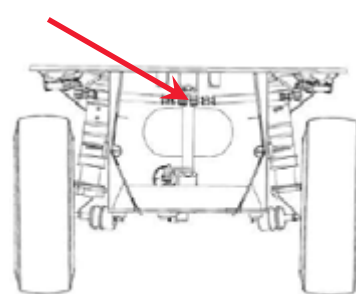

top steered

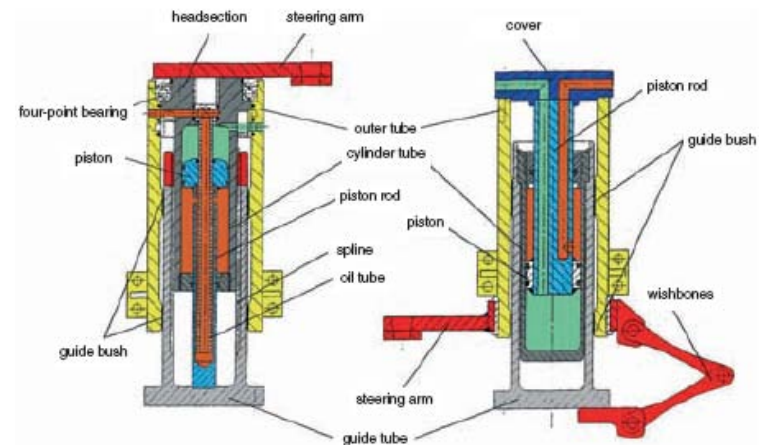

All-Wheel Steer

GMK Features - All-Wheel Steer

General

An easy to use all-wheel system gives the best steering on or off highway, eliminating tire scrub and stressed on non steering axles.

Exceptional manoeuvrability allows even the largest fully rigged GMK to get as close to the lift as possible.



Other systems, where one or more „dead weight“ hanging axles remain fixed – lead to higher axle loads, driveline maintenance problems, increased ground pressure and tire wall stress. All-wheel steer enables a fully laden crane to distribute weight evenly across all axles.

GMK Features - All-Wheel Steer

Steer By Wire



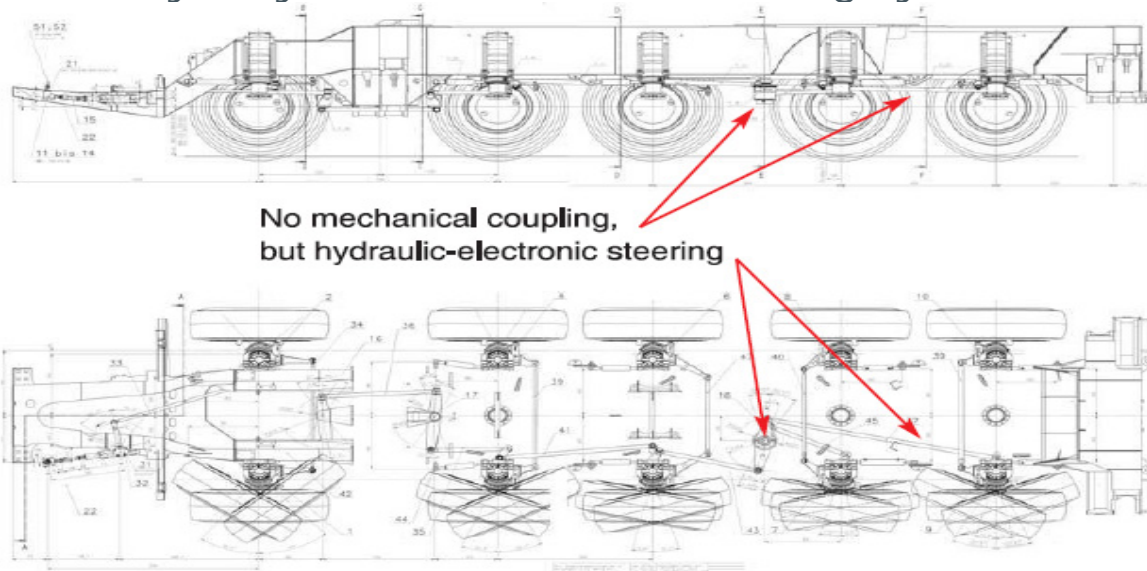

The rear 2 axles are steered by wire. Up to 12.5 mph [20 km/h] the 2 rear axles are steering depending on the driving mode (crab steer and minimum turning radius) and the speed in optimised angle. For highway travelling the 4th axle is fixed straight and up to 37 mph [60 km/h] axle 5 is steering in an optimised angle depending on the front axles and the speed. The conventional mechanical steering is replaced by a hydraulic-electronic steering system.



GMK Features - All-Wheel Steer Steer By Wire



ECOS controlled:

-  Highway travel mode
-  Crab steer mode
-  Minimum turning radius mode
-  Manual mode

The Advantages:

- Precise steering.
- Higher driving comfort.
- Reduced tyre wear.
- Economy of space by loss of the longitudinal push rods.
- More space for higher chassis.
- Weight reduction in spite of higher form stability.
- Reduction of costs by loss of the mechanical lock.
- Reduce of tire abrasion due to electronic controlled steering up to 60 km/h.
- Very convenient way of steering.



ECOS

GMK Features - ECOS Superstructure

Electronic Crane Operating System

ECOS enables control of the entire crane's principle operations. Simple programming eases lift planning and a supply of essential information allows full concentration on the lift itself:

- Operating data on all crane functions.
- Constantly running data checks and data updates.
- Error code readouts.
- ECOS is run from three identical control boxes. Should unit malfunction, crane operation will revert to the functioning units.
- Although running separately ECOS also supplies any required information to the EKS Load Moment Indicator.



The Advantages:

- Telescoping mode automatic.
- Telescoping mode semi automatic.
- Operating data on power unit.
- Adjustment and readout of all operating speeds.
- Adjusts speeds automatically when jib extensions fitted.

GMK Features - ECOS Superstructure

Control and Monitor:

- Telescope, Boom Lift, Swing and Hoist
- Efficient, precise control with user friendly diagnostics
- Constant exchange of information with EKS but works independently

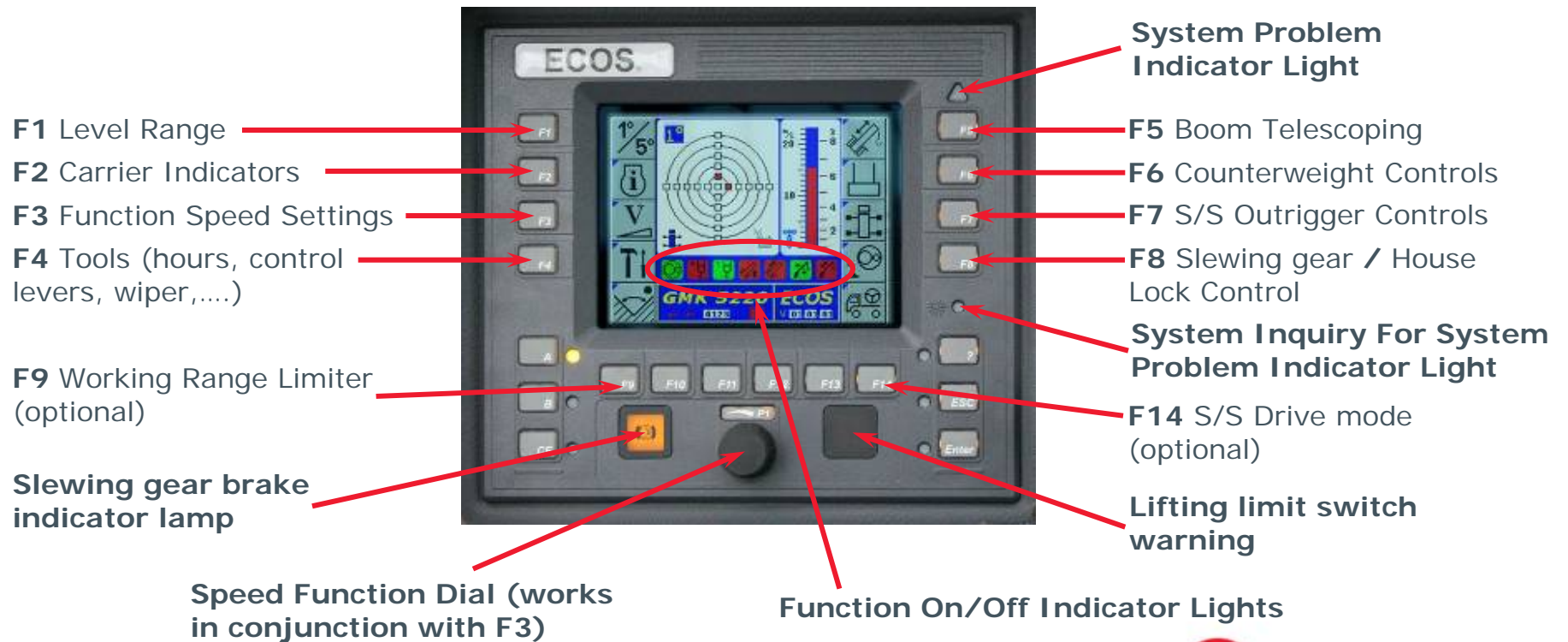

GMK Features - ECOS Carrier

Latest models feature ECOS also for the carrier functions. The ECOS screen is integrated in the carrier functions, diagnostics, warnings and error codes.



Carrier operations such as suspension and MEGATRAK™ controls, differentials and steering modes will be controlled via ECOS as well. The functions can be operated via the screen which replaces the switches usually installed in the middle console of the carrier cab.

GMK Features - ECOS Carrier



Engine Speed

F2 Info

F4 Diagnostics
(Driveline)

Temperature

Warning

Fuel

Transmission
Range & Direction

F5 Megatrak Suspension

F6 Diff Locks (long)

F7 Diff Locks (cross)

F8 Steering Modes

? Diagnostic Codes

EKS 5 / EKS 5 Light

GMK Features - EKS 5 Light Semi Graphic Display

Monitoring the lifting condition of the crane at all times EKS works together with, but independently of the ECOS as a complete command and control system or separately as load moment indicator.

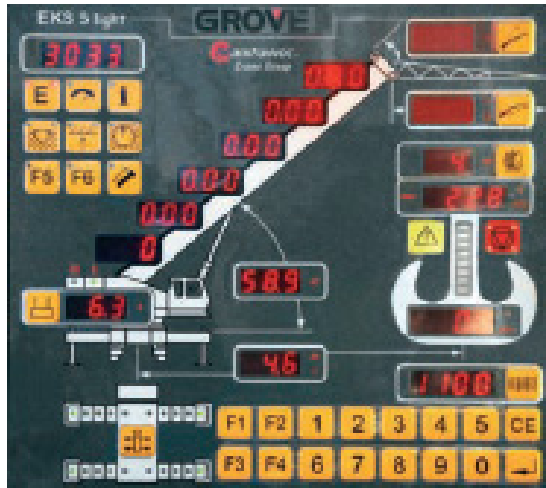

The EKS 5 light features a semi graphic display:

- Easy to use.
- Clear display.
- Ergonomic layout.

Continually running fault analysis, the system advises service codes which can be transmitted to any Crane Care centre, world-wide, allowing fast accurate investigation and recommendation.

GMK Features - EKS 5 Light Semi Graphic Display

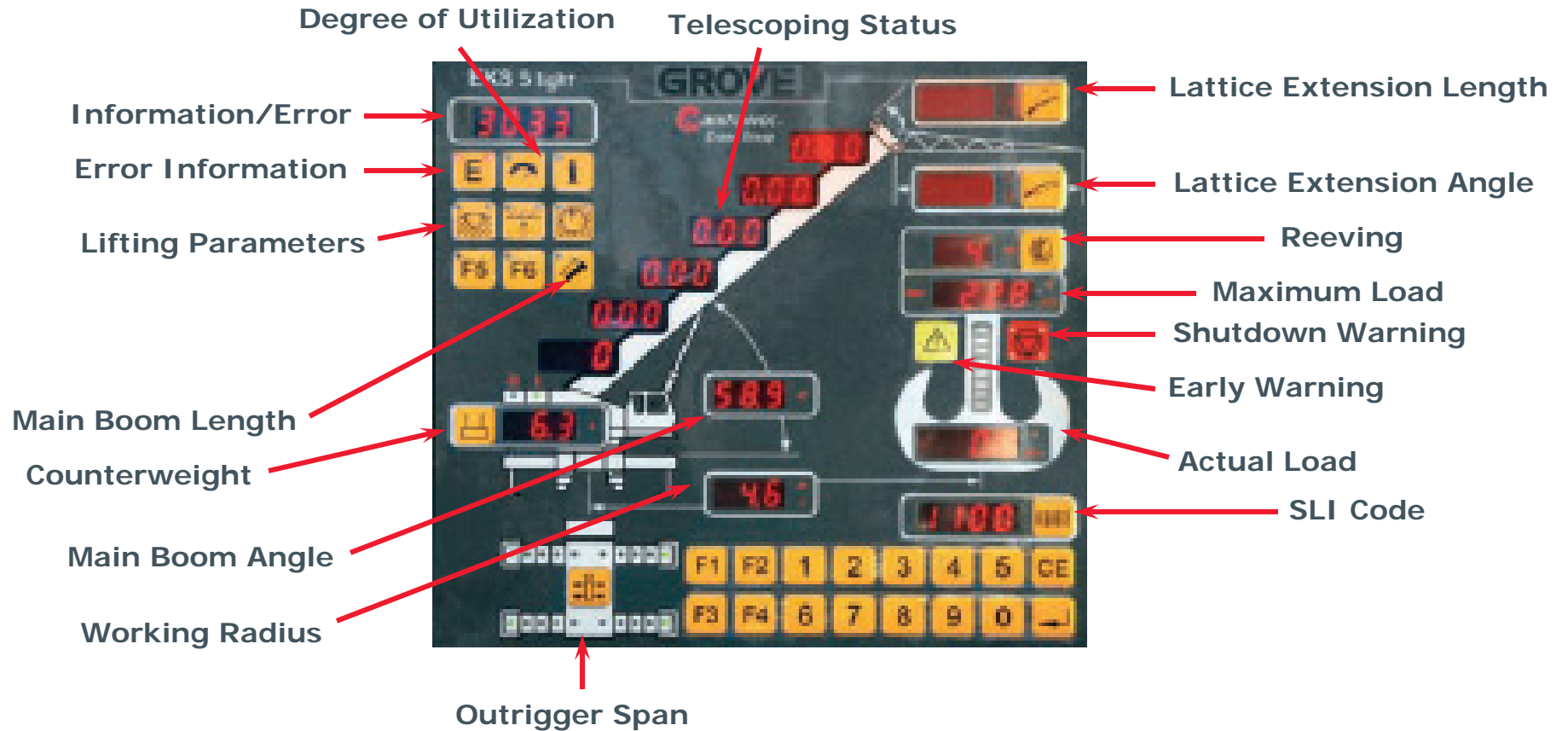

GMK Features - EKS 5

Full Graphic Display

Monitoring the lifting condition of the crane at all times EKS works together with, but independently of the ECOS as a complete command and control system or separately as load moment indicator.



The EKS 5 features in addition to the Light version a full graphic display:

- Rear lightning.
- Graphic of boom telescoping %
- Shows loadcharts.
- Allows selection of loadchart sections.

Continually running fault analysis, the system advises service codes which can be transmitted to any Crane Care centre, world-wide, allowing fast accurate investigation and recommendation.

GMK Features - EKS 5

Full Graphic Display

Main Screen

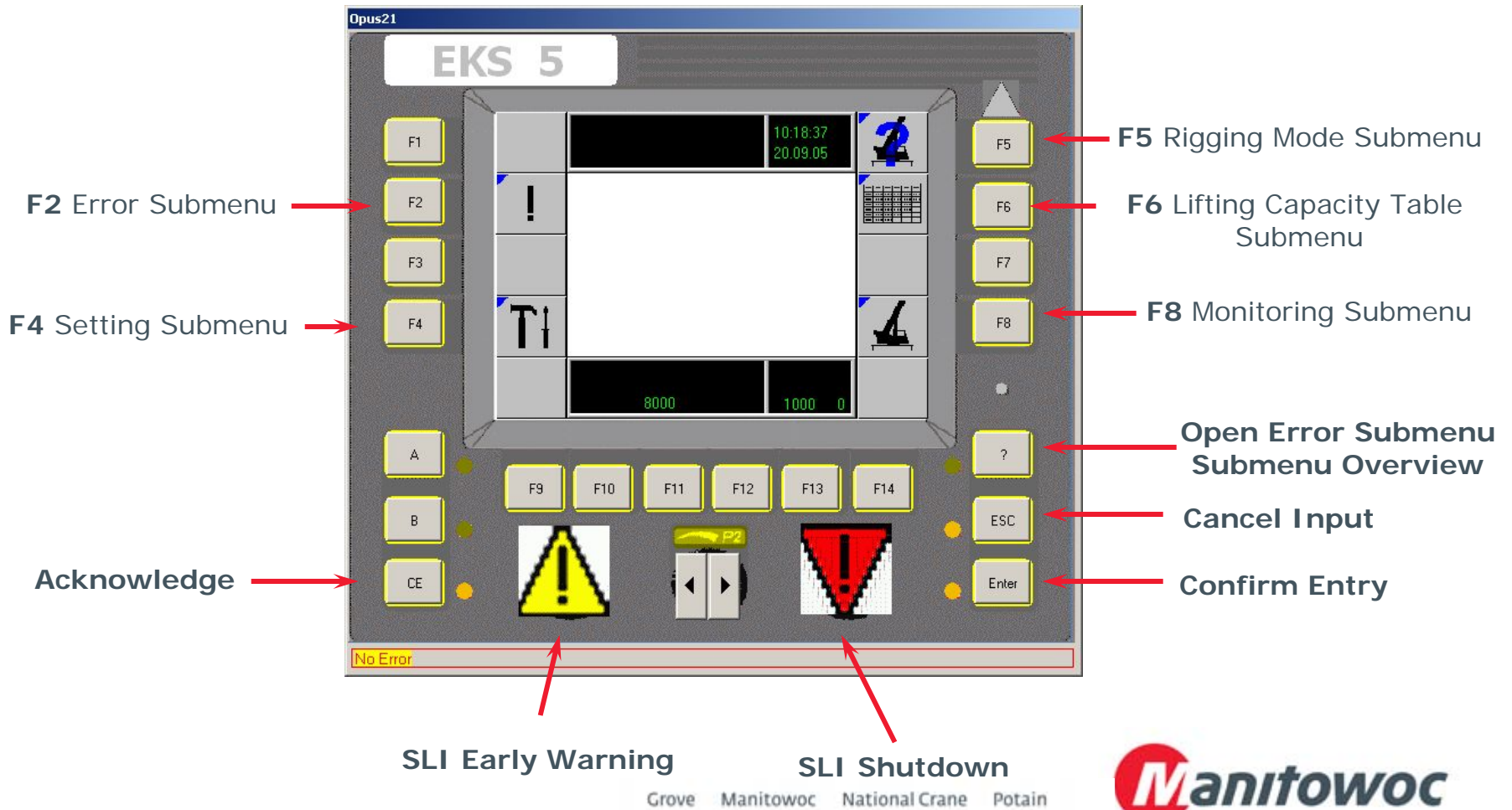

GMK Features - EKS 5

Full Graphic Display

Rigging Screen

The screenshot shows the 'Rigging Screen' for the EKS 5 crane. The screen displays various parameters and control buttons. The data shown includes:

- Counterweight: 77,0 t
- Outrigger Span: 8,90 m
- Slewing Range: 180,0°
- Reeving: 10,0
- SLI Code: 2200,0
- Maximum Capacity: 95,2 t
- Boom System: 0,0 m
- MWL: 83,0°

Control buttons and their functions are as follows:

- F1 Counterweight**: Counterweight selection
- F2 Outrigger Span**: Outrigger span selection
- F3 Slewing Range**: Slewing range selection
- F4 Reeving**: Reeving selection
- SLI Code**: SLI code selection
- F5 & F6 Selection**: Selection buttons
- F7 Boom System**: Boom system selection
- F8 MWL**: MWL selection
- ?**: Open Error Submenu
- Submenu Overview**: Submenu overview
- ESC**: Cancel Input
- Enter**: Confirm Entry
- Acknowledge**: Acknowledge (CE button)

The screen also features a 'No Error' status bar at the bottom.

GMK Features - EKS 5

Full Graphic Display

Working Screen

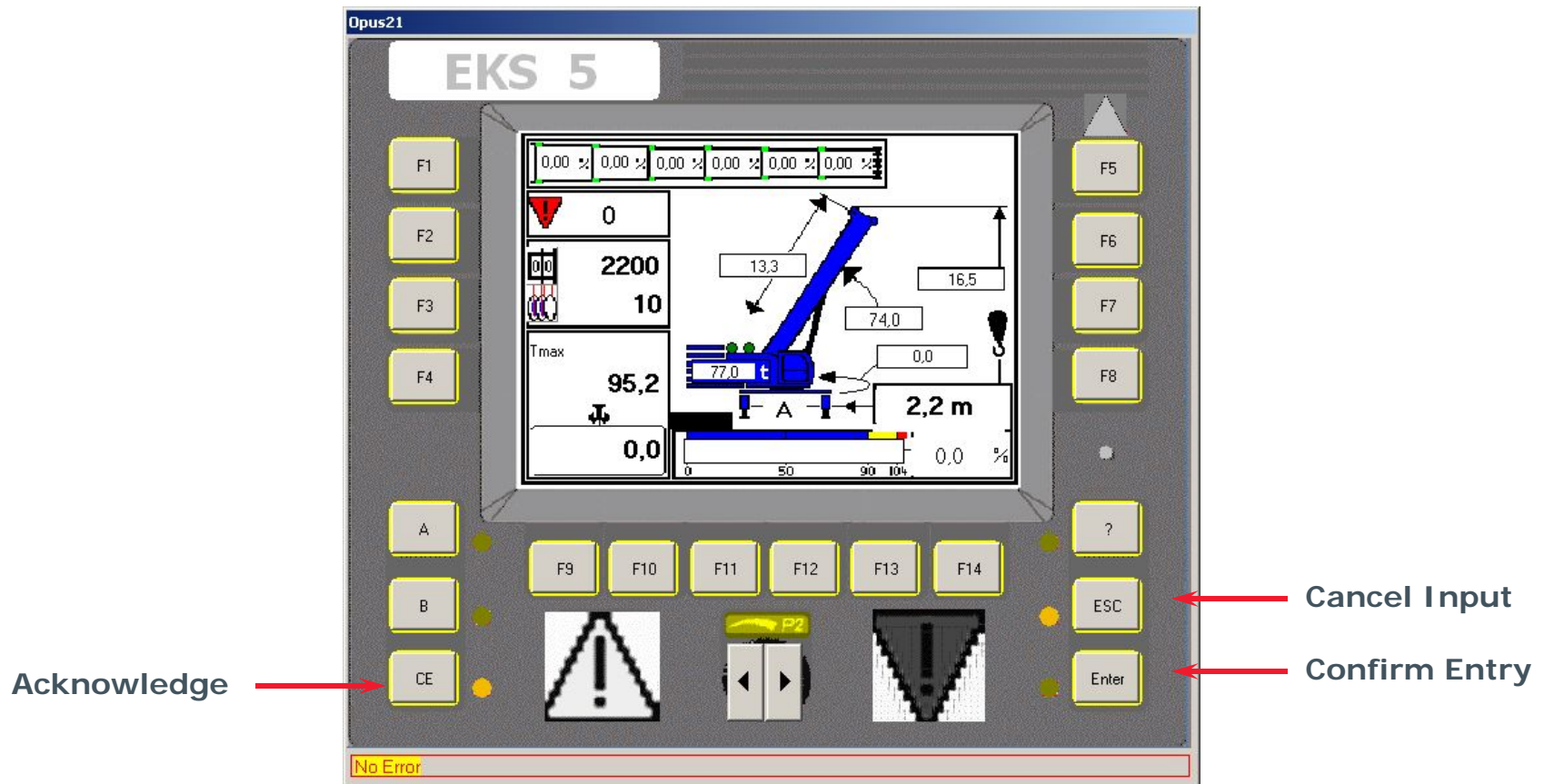

GMK Features - EKS 5

Full Graphic Display

Load Chart Screen

The screenshot shows the 'EKS 5' Load Chart Screen. The central display area contains a table with two columns of data and a vertical bar chart on the right. The table data is as follows:

0.0	150.0
4.0	150.0
5.0	127.0
6.0	110.0
7.0	96.0
8.0	85.0
9.0	76.0
10.0	67.5
10.1	54.5
-0.1	0.0
-0.1	-0.1
-0.1	-0.1
-0.1	-0.1
3.0	-0.1

Annotations and key functions:

- F5 & F6 Scroll:** Red arrows point to the F5 and F6 keys on the right side of the screen.
- Open Error Submenu Submenu Overview:** A red arrow points to the '?' key on the right side.
- Cancel Input:** A red arrow points to the ESC key on the right side.
- Confirm Entry:** A red arrow points to the Enter key on the right side.
- Acknowledge:** A red arrow points to the CE key on the left side.

At the bottom of the screen, there is a status bar that reads 'No Error'.

GMK Features - EKS 5

Full Graphic Display

Error Screen

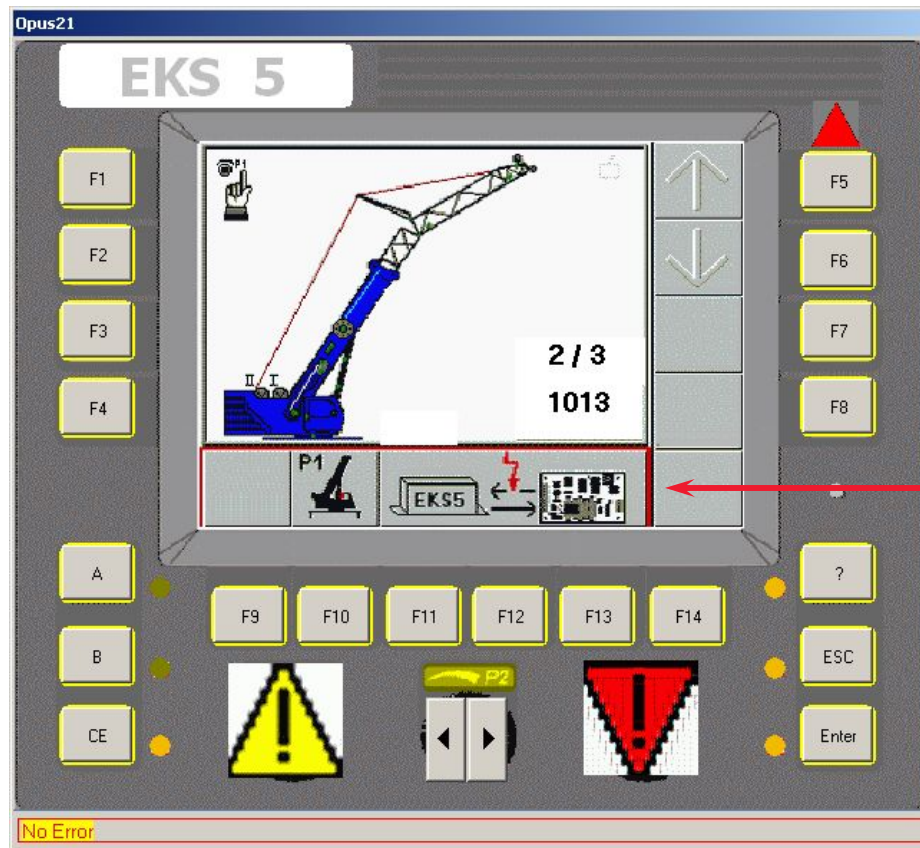

Error Definition

MEGAFORM™

GMK Features - MEGAFORM™ Boom Design

The MEGAFORM™ boom design incorporates a „U“ shaped cross-section, which provides a natural cradling position for boom sections. Large wear pads provide superior boom alignment when telescoping, and allow an excellent transition of weights between sections.

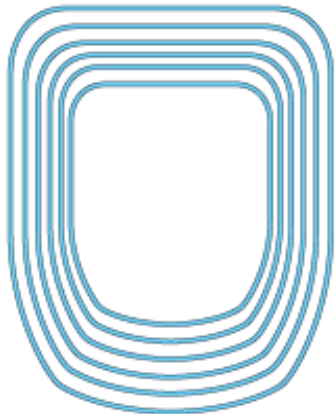

GMK 5130-1 / 5165

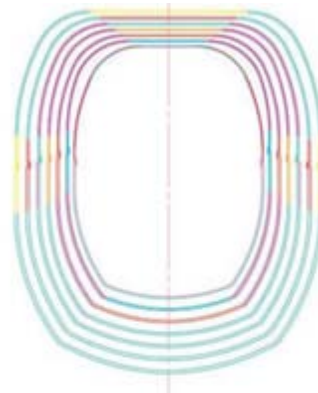

GMK 5220 / 5275



This leads to an intrinsically stronger system. In addition to less weight, a larger cross section area can be used, giving greater lifting capacity at all radii.

TWIN-LOCK™

GMK Features - TWIN-LOCK™ Pinning System

TWIN-LOCK™ is a fully hydraulic system with electronic controls. It features a single telescopic cylinder that used two horizontally-mounted pins to move a boom section into the required position.



The use of two pins increases security and their position in the side of the boom means they operate in the neutral zone.

A single telescope cylinder reduces weight used elsewhere to strengthen the crane, and increases lifting capacity.

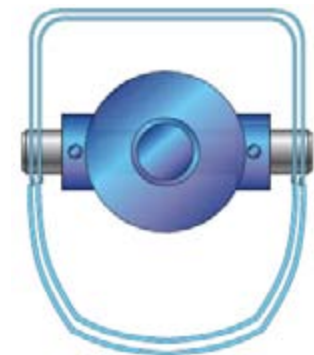

Hydraulic Jibs

GMK Features – Hydraulic Jibs

Hydraulic Luffing Jib

Grove hydraulic jibs can be offset to luff under load from 0° - 40° . The hydraulic luffing jib is controlled from the operator cab and can be used with any boom and jib configuration.

The Movement is continually monitored by the EKS system, for maximum safety.



These jibs can also be conveniently stowed alongside the boom for secure road travel.

GMK Features – Hydraulic Jibs

Integrated Heavy Duty Jib

The latest swingaway design features an integrated heavy duty jib including 3 sheaves for maximum capacities.

The heavy duty jib is hydraulic adjustable to 0° , 20° and 40° . The length is 10.8 ft [3.3 m] or 11.8 ft [3.6 m] depending on model.

Advantages:

- Saves weight: Combines bi-fold swingaway and heavy duty jib in one jib!
- More power: Higher lifting capacity on heavy duty jib due to 3 sheaves for up to 6 lines of rope!
- Increased radius when working under roof.
- Easy rigging and handling.
- Flexible to use due to hydraulic adjustment (0° - 40°).
- Included in taxi configurations with swingaway.

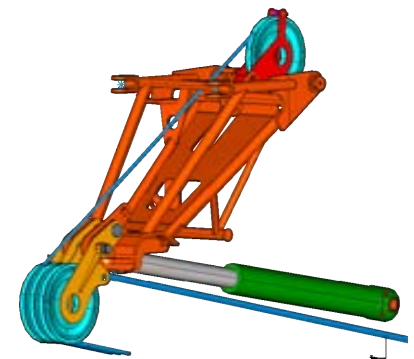

Cabs

GMK Features - Cabs

Tilting Superstructure Cab

GROVE's 20° hydraulic tilting superstructure cab gives the operator an improved and more comfortable view of the lift.



Improved lift and operator performance – better views and increased comfort means lifts are completed quicker and accurately.

Increased view of the lift 0° - 20° tilt capability gives better views.

GMK Features - Cabs

Tilting Superstructure Cab



- Aluminum construction
- Opening windshield and rear window
- Sunscreen and sun visor



- Electronic dual axis crane controls
- Hot water heater (on 2 engine cranes)
- Engine independent diesel air heater (on single engine cranes)
- Adjustable seat
- Ergonomically arranged instrumentation



GMK Features - Cabs

Tilting Superstructure Cab



ECOS EKS 5 Light



Left:

- Swing brake
- Auxiliary hoist
- Cab tilt



Right:

- Main hoist
- Telescope
- Lift
- Luffing Swingaway

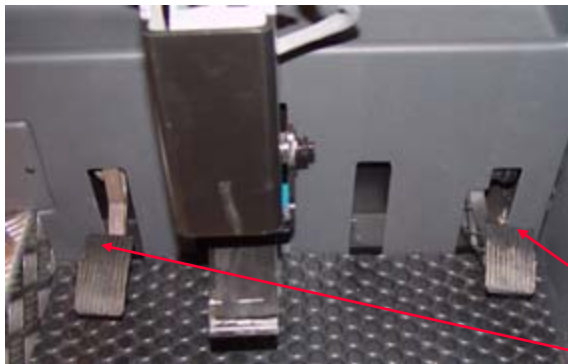

Throttle pedal
Swing brake pedal

GMK Features - Cabs

New Carrier Cab

A new design, with maximum functionality and ergonomic excellence creating the best possible working environment.



The new cab combines functional performance, ergonomic excellence and safety.

GMK Features - Cabs

New Carrier Cab



Convenience and ergonomic excellence:

- Better cab soundproofing thanks to the new plastic cladding.
 - The panoramic windshield gives excellent all-round visibility.
 - Optimised cab access.
 - Superior material processing quality.
-
- Headlamp installation optimised for easier bulb replacement.
 - Air-conditioning and parking heating system come with a timer switch as standard.
 - Air-suspension pivoting comfort seats, with shaping have been designed to provide best possible ergonomic benefits.



GMK Features - Cabs

New Carrier Cab

Integrated ECOS display screen:

- Allows operation of suspension, differentials, separate steering, and level regulation beneath the unit.
- Displays oil and water temperature, fuel level, battery and engine speed.
- Provides fault warnings for easy fault detection and trouble-shooting.



Dashboard:

Dazzle-free instrument cluster offers reduced sun glare, and enables the most important data to read at a glance.

Drive and brake Tempomat control unit:

Acceleration and braking – two functions combined in one unit.



Grove GMK6350L

Preliminary Product Guide



Features

- 15,6 m - 80 m (51 ft - 263 ft) seven-section full power MEGAFORM™ boom with TWIN-LOCK™ pinning
- 12 m - 21 m (39 ft - 69 ft) hydraulic offset bi-fold swingaway
- 1 x 8 m (26 ft) intermediate lattice insert
- 92,5 t (203,900 lb) counterweight with hydraulic removal system
- MEGATRAK™ independent hydro-pneumatic suspension

Features

Introducing the Grove GMK6350L

MEGATRAK™

The MEGATRAK™ suspension system is the best off road driveline available on the market today. The system's versatility and performance allows the GMK6350L to operate as a true all-terrain crane. The MEGATRAK™ independent suspension and all-wheel steer system allows wheels to remain on the ground at all times so stresses and weight are not continually transferred between axles. MEGATRAK™ provides true ground clearance where others just raise the chassis.

Other benefits of the MEGATRAK™ system are:

- A reliable suspension system
- Excellent job site maneuverability with all-wheel steering
- Commonality among almost all models
- A driveline that remains aligned at all times
- A steering linkage system that is protected against damage
- Constant tire contact for equal tire wear
- Reduced maintenance



TWIN-LOCK™

Boom pinning mechanism automatically pins the sections in position using two horizontal pins.



ECOS

Electronic Crane Operating System - ECOS enables control of the entire crane's principle operations. Simple programming eases lift planning and a supply of essential information allows full concentration on the lift itself.



EKS 5

The EKS 5 monitors the lifting conditions of the crane at all times and provides a full graphic display, rear lighting, graphic of boom telescoping percentage, and load charts.



Contents

Specifications	4
Dimensions	7
Weights	8
Counterweight	9
Working range (main boom)	10
Load charts (main boom)	11
Working range (hydraulically offsettable swingaway)	16
Load charts (hydraulically offsettable swingaway)	17
Working range (heavy duty jib)	18
Load charts (heavy duty jib)	19
Symbols glossary	20

Specifications

Superstructure



Boom

15,6 m - 80 m (51 ft - 263 ft) 7-section, full power MEGAFORM™ boom with TWIN-LOCK™ Pinning.
Maximum tip height: 83 m (272 ft).



Boom nose

Nine nylatron sheaves, mounted on heavy duty tapered roller bearings with removable pin-type rope guards. Quick reeve boom nose. Removable auxiliary boom nose with removable pin type rope guard.



Boom elevation

Single lift cylinder with safety valve provides boom angle from -1,5° to +83°.



*Hydraulic offsettable lattice extension

12 m - 21 m (39 ft - 69 ft) bi-fold lattice swingaway extension, hydraulically offsettable and luffing under load, 5°- 40°.
Maximum tip height: 104 m (341 ft)



*Lattice insert

1 x 8 m (26 ft) insert for use with lattice swingaway extension to increase length to 29 m (95 ft).
Maximum tip height: 112 m (367 ft)



Load moment and anti-two block system

Load moment and anti-two block system with audio/visual warning and control lever lockout provides electronic display of boom angle, length, radius, tip height, relative load moment, maximum permissible load, load indication and warning of impending two-block condition.



Cab

All aluminum constructed cab with acoustical lining, hydraulic tilted to 20°. Includes tinted safety glass, adjustable operator's seat, opening windows at side and rear, hinged windshield with wiper, sun visor and window shade. Other features include hot water heater/defroster, armrest integrated crane controls, ergonomically arranged instrumentation and radio/cd player.



Swing

3 planetary gear boxes with fixed displacement axial piston motors. Infinitely variable to 1.3 rpm. Free swing or hydrostatically engaged brake controlled by swing lever. Swing brake selected by foot operated switch.



Counterweight

92,5 t (203,900 lb) consisting of various sections with hydraulic installation/removal system controlled from the superstructure cab.



Engine

Mercedes OM 926 LA six-cylinder
Horsepower: 210 kW (286 bhp) at 2200 rpm
Torque: 1120 Nm (826 ft/lb) at 1400 rpm
Engine emissions: EPA/CARB/EUROMOT (off road)



Fuel tank capacity

300 L (79 gal)



Electrical system

3 phase alternator: 28V/80A
2 batteries: 12V/170Ah



Hydraulic system

2 (two) separate circuits, 1 (one) axial piston variable displacement pump (load sensing) with electronic power limiting control for crane functions and 1 (one) double gear pump for slewing. Thermostatically controlled oil coolers keep oil at optimum operating temperature.
Hydraulic tank capacity: 1200 L (317 gal)

Specifications

Superstructure continued



Hoist

Main and auxiliary hoist are powered by axial piston motor with planetary gear and brake. "Thumb-thumper" hoist drum rotation indicator alerts operator of hoist movement.

	Main	Auxiliary
Rope length:	350 m (1148 ft)	350 m (1148 ft)
Rope diameter:	22 mm	22 mm
Line speed:	127 m/min (417 fpm)	127 m/min (417 fpm)
Line pull:	93.5 kN (21,020 lb)	93.5 kN (21,020 lb)

Hoist camera and light included.

*Optional equipment

- ▶ Work lights, mounted on boom base section
- ▶ Boom mounted aircraft warning light
- ▶ Air conditioning
- ▶ Hook blocks/headache ball
- ▶ Engine independent diesel cab heater, with engine pre-heater. Includes 24 hour timer.
- ▶ Data logger
- ▶ 360° NYC swing lock
- ▶ 2,3 m (7.5 ft) side stowed heavy duty jib with 38 t (83,000 lb) maximum capacity using four parts of line, offset 8° and 30°
- ▶ Camera for boom head

Carrier



Chassis

Box type, torsion resistant frame is fabricated from high strength steel.



Outrigger system

Four hydraulic two stage outrigger beams with vertical cylinders and outrigger pads, 700 mm (27.6 in) round. Outrigger can be set in 5 positions:

Full:	8,5 m (27.9 ft)
Partial:	7,4 m (24.3 ft)
Partial:	6,3 m (20.7 ft)
Partial:	5,0 m (16.4 ft)
Retracted:	2,7 m (9.0 ft)

Independent horizontal and vertical movement controlled from each side of carrier and the superstructure cab.

Electronic crane level indicators. Hydraulic disconnect for all outrigger beams. Work light for each outrigger beam and outrigger pad load indicator with read out on both sides of carrier and in superstructure cabin.



Transmission

Allison automatic 4500 SP, 6 speeds forward, 1 reverse
2 speed transfer case



Drive/steer

12x6x12



Axles

1st axle line – drive/steer
2nd axle line – steer
3rd axle line – steer (connects for all wheel steer)
4th axle line – drive/steer (connects for all wheel steer)
5th axle line – drive/steer (permanent drive with 12x6, disconnects for highway with 12x8)
6th axle line – steer (optional drive)
Drive axles with planetary hub reduction and center mounted gearing. Standard inter-axle and cross axle differential locks.

Specifications

Carrier continued



Suspension

Grove exclusive MEGATRAK™ suspension. Independent hydro-pneumatic system acting on all wheels with hydraulic lockout. Suspension can be raised 170 mm (6.7 in) or lowered 126 mm (5.0 in), both longitudinally and transversely. Features an automatic leveling system for highway travel.



Tires

12 tires, 16.00R25 (Vehicle width – 3,0 m [9.8 ft])



Steering

Dual circuit, hydraulic power assisted steering system. Transfer case mounted, ground driven emergency steering pump. Axles 1, 2, 5 and 6 steer on highway. Separate steering (steer by wire) of the 3rd to 6th axles for all wheel and crab steering, controlled by an electronic rocker switch.



Engine

Mercedes OM 502 LA, eight-cylinder
Horsepower: 405 kW (551 bhp) at 2100 rpm
Torque: 2600 Nm (1918 ft/lb) at 1300 rpm
Engine emissions: EPA /CARB/EUROMOT (off road)



Fuel tank capacity

500 L (132 gal). Installed on superstructure.



Brakes

Service brakes: pneumatic dual circuit acting on all wheels.
Parking brake: pneumatically operated spring loaded brake acting on axle lines 2, 4, 5 and 6.
Air dryer.



Cab

Two-man, composite designed aluminum and fiber reinforced plastic construction with the following features: safety glass, driver seat with pneumatic suspension, engine-dependent hot water heater, power windows, heated rear view mirrors, complete instrumentation, driving controls, reversing camera system, air conditioning, radio/cd player, 12V plug and fire extinguisher.



Electrical system

24V system with three phase alternator, 28V/100A
2 batteries, 12V/170 Ah



Maximum speed

85 km/h (53 mph)



Gradeability (theoretical)

49% - 14.00 tires
43% - 16.00/20.5 tires

Miscellaneous standard equipment

Work lights; tool kit, fire extinguishers; auxiliary boom nose, and wind speed indicator.

*Optional equipment

- ▶ 14.00R25 tires (vehicle width. 3,0 m [9.8 ft])
- ▶ 20.5R25 tires (vehicle width. 3,1 m [10.2 ft])
- ▶ 12x8x12 drive/steer
- ▶ Transmission retarder
- ▶ Engine independent diesel cab heater, with engine pre-heater. Includes 24 hour timer.
- ▶ Spare tire and wheel with carry bracket
- ▶ Rear mounted stowage box
- ▶ Trailer hitch
- ▶ Outrigger length sensors

Dimensions

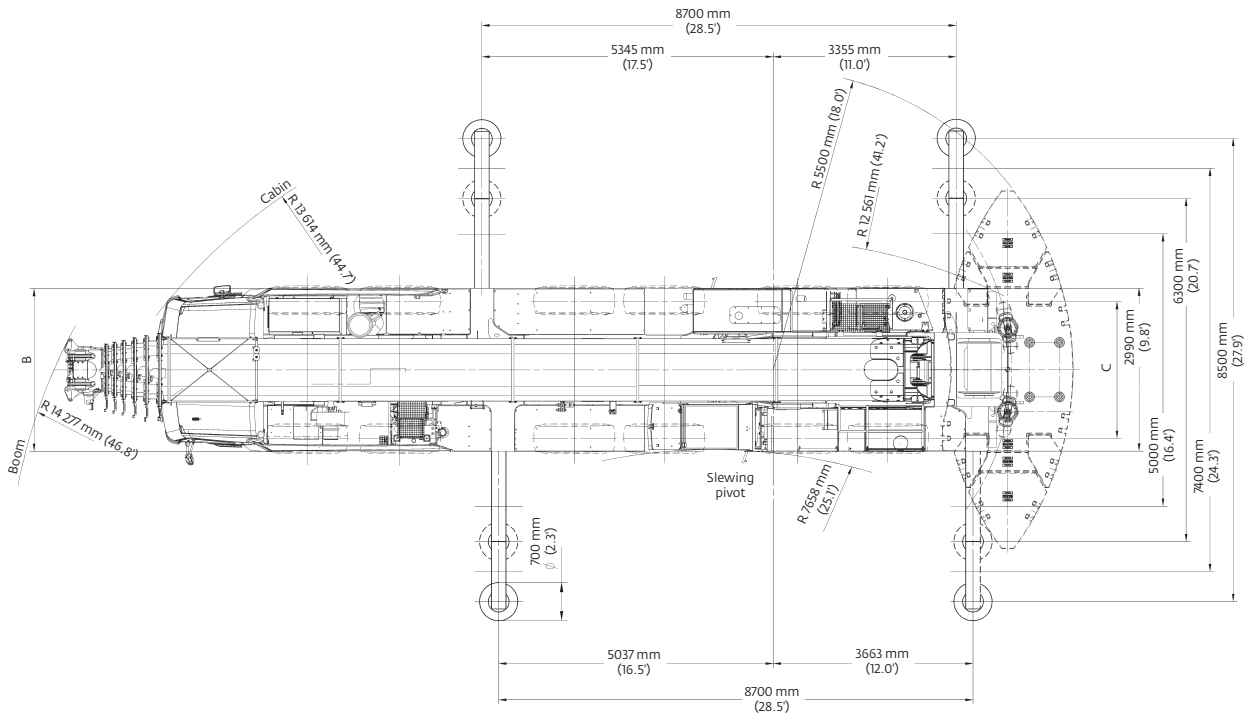
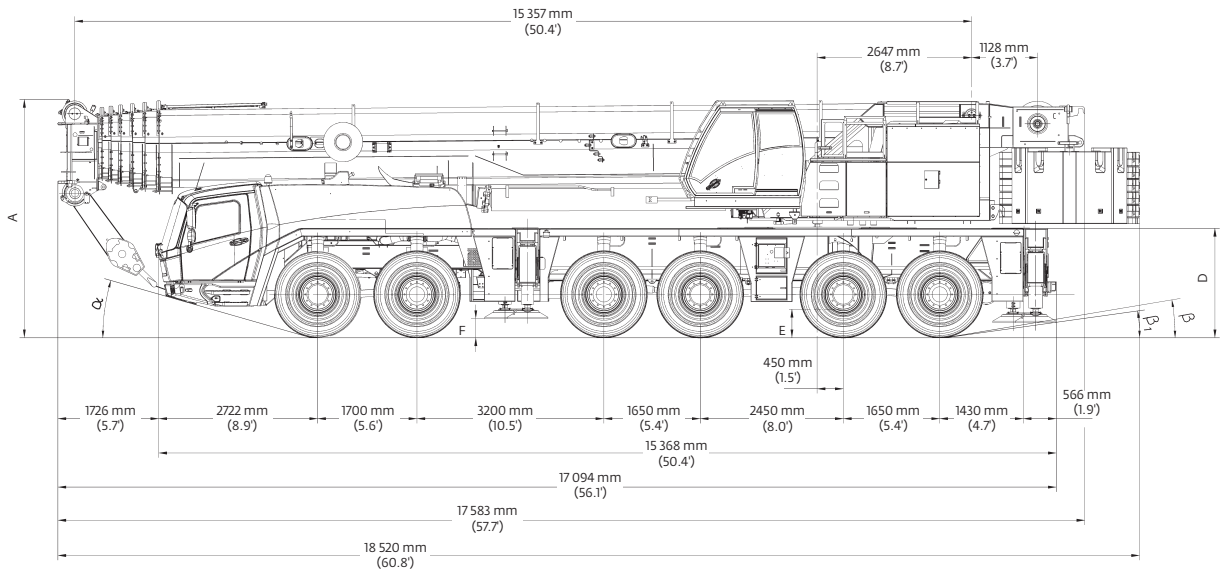

Tires	A	A ^{130 mm (5.1)}	B	C	D	E	F	α	β	β_1
14.00 R25	3950 mm (13.0')	3820 mm (12.5')	2970 mm (9.7')	2570 mm (8.4')	1822 mm (6.0')	400 mm (1.3')	297 mm (1.0')	14°	8°	6°
16.00 R25	4000 mm (13.1')	3870 mm (12.7')	2975 mm (9.8')	2510 mm (8.2')	1872 mm (6.1')	450 mm (1.5')	327 mm (1.1')	16°	10°	8°
20.5 R25	4000 mm (13.1')	3870 mm (12.7')	3070 mm (10.1')	2530 mm (8.3')	1872 mm (6.1')	450 mm (1.5')	327 mm (1.1')	16°	10°	8°

Ra = Radius all wheels steered
^oLowered

Weights

Boom over front

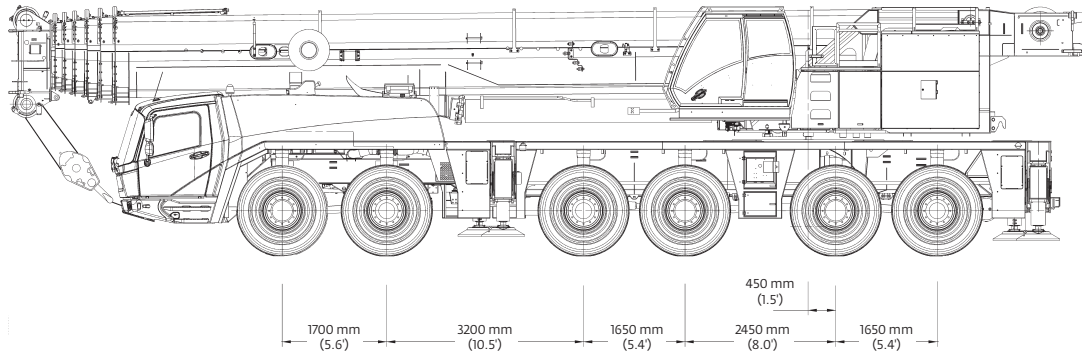

Basic Weights - kg (lb)	Axles 1 and 2		Axles 3 - 6		Total	
Mercedes power, 16.00R25 tires, 12x6x12 drive/steer, 2nd oil cooler, outrigger pads, driver and tanks filled	22 927	(50,545)	48 993	(108,011)	71 920	(158,556)
Additions:						
12x8x12 drive/steer	- 222	(-489)	612	(1349)	390	(860)
Spare wheel 14.00 R25 XGC steel rim with stowage	-199	(-439)	464	(1023)	265	(584)
Spare wheel 16.00 R25 XGC steel rim with stowage	- 244	(-538)	569	(1254)	325	(717)
Spare wheel 20.5 R25 XGC steel rim with stowage	- 278	(-613)	645	(1422)	367	(809)
Brackets for hydraulic swingaway	100	(220)	0	(0)	100	(220)
Hose reel + parts for hydraulic swingaway	110	(243)	120	(265)	230	(507)
11 m - 18 m (36 ft - 59 ft) hydraulic swingaway	2525	(5567)	- 515	(-1135)	2010	(4431)
Auxiliary hoist	-2509	(-5,531)	5269	(11,616)	2760	(6085)
7000 kg (15,400 lb) base plate stowed on carrier	3662	(8073)	3338	(7359)	7000	(15,432)
9500 kg (20,900 lb) slab on top of base plate stowed on carrier	4970	(10,957)	4530	(9987)	9500	(20,944)
Substitutions:						
14.00R25 tires	- 240	(-529)	- 480	(-1058)	- 720	(-1587)
20.5R25 tires	168	(370)	336	(741)	504	(1111)
Removals:						
Boom assembly without lift cylinder	-17 034	(-37,554)	-10 499	(-23,146)	-27 533	(-60,700)
Front outriggers	-1655	(-3649)	- 890	(-1962)	-2545	(-5611)
Rear outriggers	1842	(4061)	-4675	(-10,307)	-2833	(-6246)
Front and rear outrigger floats	0	(0)	- 350	(-772)	- 350	(-772)

Counterweight

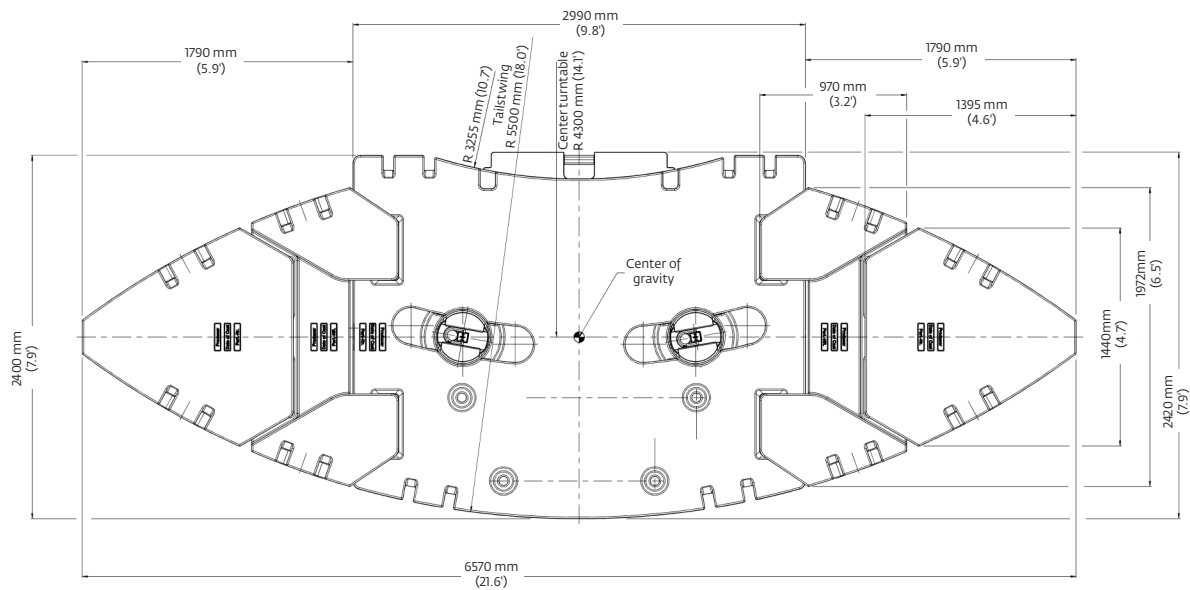
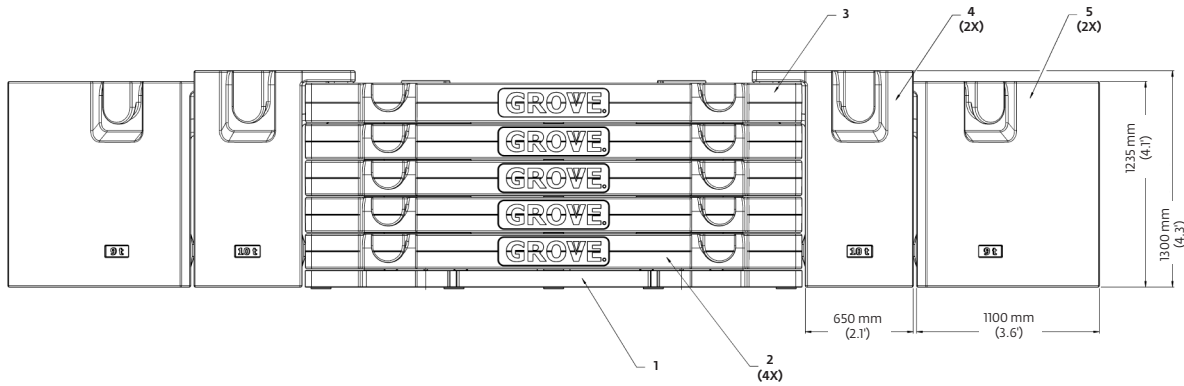

	1 7,0 t (15,430 lb)	2 9,5 t (20,940 lb)	3 9,5 t (20,940 lb)	4 10,0 t (22,050 lb)	5 9,0 t (19,840 lb)
7,0 t (15,400 lb)	X	-	-	-	-
16,5 t (36,400 lb)	X	X	-	-	-
26,0 t (57,300 lb)	X	2 X	-	-	-
35,5 t (78,300 lb)	X	3 X	-	-	-
45,0 t (99,200 lb)	X	4 X	-	-	-
54,5 t (120,200 lb)	X	4 X	X	-	-
74,5 t (164,200 lb)	X	4 X	X	2 X	-
92,5 t (203,900 lb)	X	4 X	X	2 X	2 X

Working range

Main boom

51 ft - 263 ft main boom

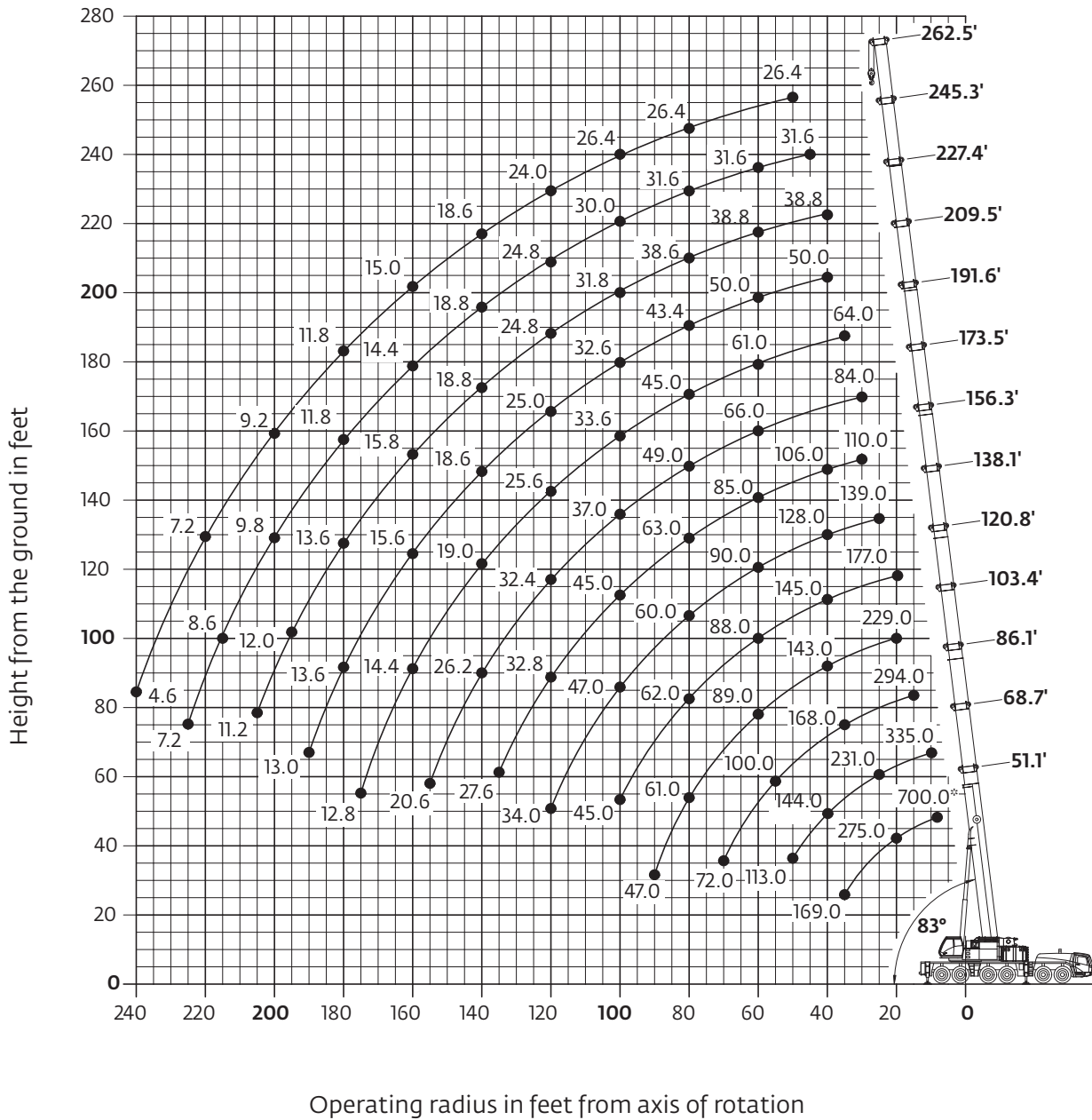

Hook heights shown in the working diagram do not consider loaded boom deflection.

	Hook block	H
	200 ton, 9 sheave	12.0 ft (3650 mm)
160 ton, 7 sheave	12.0 ft (3650 mm)	
125 ton, 5 sheave	10.8 ft (3300 mm)	
80 ton, 3 sheave	10.8 ft (3300 mm)	
32 ton, 1 sheave	10.5 ft (3200 mm)	
12 ton, single line headache ball	8.0 ft (2450 mm)	

THIS CHART IS ONLY A GUIDE AND SHOULD NOT BE USED TO OPERATE THE CRANE.

The individual crane's load chart, operating instructions and other instructional plates must be read and understood prior to operating the crane

Load charts

Main boom





15,6 m - 80 m (51.1 ft - 262.5 ft)
 92 500 kg (203,900 lb)
 26 ft 7 in spread (100%)
 360°



 Pounds x 1000

Feet	51.1'	68.7'	86.1'	103.4'	120.8'	138.1'	156.3'	173.5'	191.6'	209.5'	227.4'	245.3'	262.5'				
8.0	700.0*																
10.0	416.0	335.0															
15.0	336.0	316.0	294.0														
20.0	275.0	271.0	256.0	229.0	177.0												
25.0	232.0	231.0	223.0	215.0	177.0	139.0											
30.0	199.0	198.0	196.0	190.0	175.0	139.0	110.0	84.0									
35.0	169.0	169.0	168.0	167.0	161.0	137.0	110.0	84.0	64.0								
40.0		144.0	144.0	143.0	145.0	128.0	106.0	84.0	64.0	50.0	38.8						
45.0		127.0	125.0	124.0	126.0	118.0	101.0	83.0	64.0	50.0	38.8	31.6					
50.0		113.0	112.0	110.0	110.0	110.0	96.0	77.0	64.0	50.0	38.8	31.6	26.4				
55.0			100.0	99.0	98.0	100.0	91.0	71.0	63.0	50.0	38.8	31.6	26.4				
60.0			90.0	89.0	88.0	90.0	85.0	66.0	61.0	50.0	38.8	31.6	26.4				
65.0			81.0	79.0	78.0	81.0	80.0	60.0	57.0	50.0	38.8	31.6	26.4				
70.0			72.0	72.0	73.0	73.0	74.0	56.0	53.0	48.0	38.8	31.6	26.4				
75.0				66.0	67.0	66.0	68.0	52.0	49.0	46.0	38.8	31.6	26.4				
80.0				61.0	62.0	60.0	63.0	49.0	45.0	43.4	38.6	31.6	26.4				
85.0				58.0	57.0	55.0	58.0	44.0	42.0	40.4	37.4	31.6	26.4				
90.0				47.0	52.0	53.0	53.0	40.6	38.8	37.4	35.6	31.6	26.4				
95.0					49.0	50.0	49.0	38.4	36.0	35.0	33.6	31.0	26.4				
100.0					45.0	47.0	45.0	37.0	33.6	32.6	31.8	30.0	26.4				
105.0						43.8	41.6	35.8	31.2	30.4	30.0	28.6	26.4				
110.0						40.6	38.4	34.6	29.4	28.6	28.2	27.4	26.0				
115.0						37.8	35.6	33.4	27.4	26.8	26.6	26.0	25.0				
120.0							32.8	32.4	25.6	25.0	24.8	24.8	24.0				
125.0							30.4	31.4	24.2	23.4	23.2	23.6	23.0				
130.0							28.4	30.0	22.6	22.0	21.8	22.2	21.4				
135.0							27.6	28.0	20.8	20.2	20.2	20.6	19.8				
140.0								26.2	19.0	18.6	18.8	18.8	18.6				
145.0								24.4	17.2	17.4	17.8	17.0	17.8				
150.0								22.8	16.2	16.8	17.0	16.0	17.0				
155.0								20.6	15.2	16.2	16.4	15.2	16.0				
160.0									14.4	15.6	15.8	14.4	15.0				
165.0									13.8	15.2	15.2	13.8	14.2				
170.0										13.2	14.6	13.0	13.4				
175.0										12.8	14.2	12.4	12.4				
180.0											13.6	11.8	11.8				
185.0											13.4	13.0	11.4	11.0			
190.0											13.0	12.6	10.8	10.4			
195.0												12.0	10.4	9.8			
200.0												11.6	9.8	9.2			
205.0												11.2	9.4	8.6			
210.0													9.0	8.2			
215.0														8.6	7.6		
220.0															8.2	7.2	
225.0																7.2	6.6
230.0																	6.0
235.0																	5.2
240.0																	4.6

* Over the rear with special equipment
 Loads greater than 394,000 lb can only be lifted with special equipment.

Load charts

Main boom

 15,6 m - 80 m
 (51.1 ft - 262.5 ft)
  74 500 kg
 (164,200 lb)
  26 ft 7 in spread
 (100%)
  360°















Pounds x 1000

Feet	51.1'	68.7'	86.1'	103.4'	120.8'	138.1'	156.3'	173.5'	191.6'	209.5'	227.4'	245.3'	262.5'
10.0	416.0	335.0											
15.0	331.0	316.0	294.0										
20.0	271.0	268.0	256.0	229.0	177.0								
25.0	228.0	225.0	223.0	215.0	177.0	139.0							
30.0	187.0	186.0	186.0	184.0	175.0	139.0	110.0	84.0					
35.0	157.0	157.0	156.0	155.0	156.0	137.0	110.0	84.0	64.0				
40.0		135.0	134.0	133.0	133.0	128.0	106.0	84.0	64.0	50.0	38.8		
45.0		117.0	117.0	117.0	114.0	116.0	101.0	83.0	64.0	50.0	38.8	31.6	
50.0		101.0	103.0	101.0	100.0	102.0	96.0	77.0	64.0	50.0	38.8	31.6	26.4
55.0			90.0	90.0	91.0	90.0	90.0	71.0	63.0	50.0	38.8	31.6	26.4
60.0			80.0	80.0	82.0	80.0	82.0	66.0	61.0	50.0	38.8	31.6	26.4
65.0			72.0	75.0	74.0	72.0	74.0	60.0	57.0	50.0	38.8	31.6	26.4
70.0			65.0	67.0	66.0	66.0	67.0	56.0	53.0	48.0	38.8	31.6	26.4
75.0				61.0	60.0	61.0	60.0	52.0	49.0	46.0	38.8	31.6	26.4
80.0				55.0	54.0	56.0	54.0	49.0	45.0	43.4	38.6	31.6	26.4
85.0				49.0	50.0	51.0	49.0	44.0	42.0	40.4	37.4	31.6	26.4
90.0				45.0	47.0	47.0	44.0	41.0	38.8	37.4	35.6	31.6	26.4
95.0					43.8	42.6	40.0	38.6	36.0	35.0	33.6	31.0	26.4
100.0					40.0	38.6	36.2	37.0	33.6	32.6	31.8	30.0	26.4
105.0						35.4	33.0	35.2	30.8	30.4	30.0	28.6	26.4
110.0							32.6	32.0	32.4	28.0	28.0	27.4	26.0
115.0							30.0	31.0	30.0	25.4	25.6	26.4	25.0
120.0							28.0	29.6	27.6	23.0	23.4	24.4	24.8
125.0								27.6	25.4	20.8	21.6	22.6	23.2
130.0								25.6	23.4	19.0	20.4	21.0	21.4
135.0								23.8	21.6	17.6	19.0	19.8	19.6
140.0									20.0	16.6	18.0	18.6	18.0
145.0									18.4	16.0	17.4	17.8	16.6
150.0									17.0	15.4	16.8	17.0	15.8
155.0										15.8	16.2	16.4	15.2
160.0											14.2	15.6	14.4
165.0												14.8	13.8
170.0													13.8
175.0													12.8
180.0													12.8
185.0													11.8
190.0													11.2
195.0													9.2
200.0													8.6
205.0													8.2
210.0													6.8
215.0													6.2
220.0													5.4
225.0													4.8
													4.2

Load charts

Main boom

 15,6 m - 80 m (51.1 ft - 262.5 ft)													 54 500 kg (120,200 lb)		 26 ft 7 in spread (100%)		 360°	
  Pounds x 1000																		
Feet	51.1'	68.7'	86.1'	103.4'	120.8'	138.1'	156.3'	173.5'	191.6'	209.5'	227.4'	245.3'	262.5'					
10.0	409.0	335.0																
15.0	325.0	315.0	294.0															
20.0	265.0	263.0	255.0	229.0	177.0													
25.0	210.0	209.0	209.0	208.0	177.0	139.0												
30.0	170.0	172.0	169.0	168.0	167.0	139.0	110.0	84.0										
35.0	139.0	141.0	143.0	141.0	137.0	132.0	110.0	84.0	64.0									
40.0		119.0	120.0	120.0	120.0	113.0	106.0	84.0	64.0	50.0	38.8							
45.0		104.0	103.0	104.0	103.0	97.0	96.0	83.0	64.0	50.0	38.8	31.6						
50.0		89.0	88.0	92.0	90.0	86.0	84.0	77.0	64.0	50.0	38.8	31.6	26.4					
55.0			77.0	79.0	78.0	78.0	74.0	70.0	62.0	50.0	38.8	31.6	26.4					
60.0			68.0	68.0	67.0	70.0	66.0	62.0	58.0	50.0	38.8	31.6	26.4					
65.0			59.0	59.0	62.0	62.0	58.0	55.0	53.0	50.0	38.8	31.6	26.4					
70.0			53.0	53.0	56.0	55.0	51.0	50.0	47.0	45.0	38.8	31.6	26.4					
75.0				48.0	50.0	48.0	46.0	46.0	41.6	40.8	38.4	31.6	26.4					
80.0				45.0	45.0	43.0	41.2	43.0	37.4	36.8	37.0	31.6	26.4					
85.0				40.6	40.2	38.8	39.0	38.8	33.8	32.8	33.2	31.6	26.4					
90.0				36.8	36.4	35.0	36.8	35.0	30.2	30.2	30.8	30.6	26.4					
95.0					33.0	32.8	34.0	31.6	27.2	28.2	29.2	29.4	26.4					
100.0					30.0	31.4	30.8	28.4	25.2	27.0	27.8	28.0	25.8					
105.0						29.6	28.0	25.8	23.8	25.6	26.6	26.4	23.8					
110.0						27.2	25.6	23.4	22.8	24.6	25.0	24.2	21.8					
115.0						25.0	23.6	21.4	21.8	23.2	23.0	22.2	19.8					
120.0						23.2	21.6	19.4	20.4	21.8	21.2	20.2	18.2					
125.0							19.8	17.6	18.6	20.8	19.4	18.4	16.4					
130.0							18.0	15.8	18.0	19.4	18.0	16.8	15.0					
135.0							16.6	14.4	17.2	17.8	16.4	15.2	13.4					
140.0								13.0	16.4	16.4	15.0	13.8	12.0					
145.0								11.6	15.2	15.0	13.8	12.4	10.6					
150.0								10.4	14.2	13.8	12.6	11.2	9.2					
155.0								9.2	13.2	12.8	11.4	10.0	8.0					
160.0									12.4	11.6	10.2	8.8	7.0					
165.0									11.4	10.6	9.2	7.8	6.0					
170.0									10.4	9.6	8.2	6.8	5.0					
175.0									9.6	8.8	7.2	5.8	4.0					
180.0										8.0	6.4	5.0						
185.0										7.0	5.6	4.2						
190.0										6.2	4.8	3.4						
195.0											4.0							
200.0												3.4						

 15,6 m - 80 m (51.1 ft - 262.5 ft)													 45 000 kg (99,200 lb)		 26 ft 7 in spread (100%)		 360°	
  Pounds x 1000																		
Feet	51.1'	68.7'	86.1'	103.4'	120.8'	138.1'	156.3'	173.5'	191.6'	209.5'	227.4'	245.3'	262.5'					
10.0	407.0	335.0																
15.0	322.0	314.0	294.0															
20.0	256.0	254.0	252.0	228.0	177.0													
25.0	201.0	200.0	200.0	195.0	176.0	139.0												
30.0	160.0	161.0	162.0	159.0	148.0	137.0	110.0	84.0										
35.0	131.0	133.0	134.0	129.0	127.0	118.0	110.0	84.0	64.0									
40.0		112.0	112.0	113.0	106.0	99.0	98.0	84.0	64.0	50.0	38.8							
45.0		94.0	93.0	97.0	91.0	90.0	84.0	78.0	64.0	50.0	38.8	31.6						
50.0		78.0	81.0	81.0	79.0	79.0	73.0	68.0	63.0	50.0	38.8	31.6	26.4					
55.0			69.0	69.0	71.0	70.0	65.0	60.0	57.0	50.0	38.8	31.6	26.4					
60.0			60.0	60.0	63.0	61.0	57.0	54.0	50.0	49.0	38.8	31.6	26.4					
65.0			54.0	55.0	55.0	54.0	50.0	51.0	44.0	43.0	38.8	31.6	26.4					
70.0			48.0	49.0	49.0	47.0	46.0	46.0	39.4	38.4	37.2	31.6	26.4					
75.0				43.6	43.4	41.6	42.6	41.6	34.8	35.0	35.2	31.6	26.4					
80.0				38.8	38.4	37.6	39.6	37.2	31.2	32.6	33.2	31.4	26.4					
85.0				34.8	34.4	35.8	35.4	33.0	29.4	31.2	31.8	31.4	26.4					
90.0				31.4	31.4	33.2	31.8	29.6	27.8	29.6	30.2	28.6	25.4					
95.0					29.6	30.4	28.8	26.4	26.4	28.0	28.2	26.0	23.4					
100.0					28.2	27.6	26.2	23.8	25.2	26.4	26.0	23.8	21.2					
105.0						25.2	23.6	21.4	23.8	25.0	23.6	21.6	19.2					
110.0						23.0	21.4	19.0	22.6	22.8	21.4	19.6	17.2					
115.0						21.0	19.4	17.0	21.0	20.8	19.4	17.8	15.4					
120.0						19.2	17.6	15.0	19.2	19.0	17.6	16.0	13.8					
125.0							16.0	13.4	17.6	17.4	15.8	14.2	12.2					
130.0							14.6	11.6	16.4	15.6	14.2	12.8	10.8					
135.0							13.8	10.2	15.0	14.2	12.8	11.2	9.4					
140.0								9.0	13.6	12.8	11.4	9.8	8.0					
145.0								7.8	12.4	11.6	10.0	8.6	6.6					
150.0								6.6	11.2	10.4	8.8	7.4	5.6					
155.0								5.6	10.0	9.4	7.8	6.4	4.4					
160.0									9.0	8.4	6.8	5.4	3.4					
165.0									8.2	7.4	5.8	4.4						
170.0									7.2	6.4	5.0	3.4						
175.0									6.4	5.6	3.8							
180.0										4.8	3.2							
185.0										4.0								
190.0											3.4							

THIS CHART IS ONLY A GUIDE AND SHOULD NOT BE USED TO OPERATE THE CRANE.

Load charts





Main boom

15,6 m - 80 m (51.1 ft - 262.5 ft) 98 500 kg (78,300 lb) 26 ft 7 in spread (100%) 360°													
Pounds x 1000													
Feet	51.1'	68.7'	86.1'	103.4'	120.8'	138.1'	156.3'	173.5'	191.6'	209.5'	227.4'	245.3'	262.5'
10.0	403.0	335.0											
15.0	320.0	312.0	294.0										
20.0	245.0	243.0	241.0	226.0	177.0								
25.0	190.0	189.0	191.0	176.0	163.0	139.0							
30.0	149.0	152.0	149.0	140.0	135.0	124.0	110.0	84.0					
35.0	120.0	125.0	120.0	119.0	111.0	105.0	101.0	84.0	64.0				
40.0		100.0	100.0	98.0	93.0	92.0	84.0	79.0	64.0	50.0	38.8		
45.0		81.0	84.0	83.0	83.0	79.0	73.0	67.0	62.0	50.0	38.8	31.6	
50.0		68.0	70.0	70.0	72.0	68.0	63.0	60.0	55.0	50.0	38.8	31.6	26.4
55.0			61.0	62.0	63.0	60.0	55.0	55.0	48.0	46.0	38.8	31.6	26.4
60.0			54.0	55.0	54.0	53.0	50.0	49.0	41.6	41.0	38.6	31.6	26.4
65.0			46.0	47.0	47.0	46.0	48.0	43.4	37.2	38.4	38.0	31.6	26.4
70.0			40.6	41.8	41.4	42.4	42.6	38.6	34.8	36.6	36.2	31.6	26.4
75.0				37.0	37.0	38.8	37.6	34.4	32.8	34.2	33.6	30.4	26.2
80.0				32.8	33.6	34.8	33.2	30.6	31.0	31.8	30.6	28.2	25.2
85.0				29.2	31.6	31.0	29.6	26.8	29.4	29.8	27.6	25.0	22.4
90.0				27.4	28.6	28.0	26.4	23.6	27.6	27.2	25.0	22.6	20.0
95.0					25.6	25.6	23.4	20.8	25.4	24.8	22.6	20.2	17.8
100.0					23.2	23.6	20.8	18.2	23.0	22.4	20.4	18.2	15.8
105.0						22.0	18.6	15.8	20.8	20.0	18.2	16.4	13.8
110.0						20.2	17.6	13.8	18.8	18.0	16.4	14.4	12.2
115.0						18.4	16.8	12.0	16.8	16.2	14.6	12.8	10.6
120.0						16.6	15.8	10.2	15.0	14.4	12.8	11.4	9.2
125.0							15.0	8.8	13.6	12.6	11.4	9.8	7.8
130.0							13.6	7.4	12.0	11.4	9.8	8.4	6.6
135.0							12.2	6.0	10.8	10.0	8.6	7.0	5.2
140.0								4.8	9.6	8.8	7.4	5.8	4.0
145.0								3.8	8.4	7.6	6.2	4.8	
150.0								2.8	7.4	6.6	5.2	3.8	
155.0									6.4	5.8	4.2		
160.0									5.6	4.8			
165.0									4.8	3.8			
170.0									4.0	3.2			
175.0									3.4				



15,6 m - 80 m (51.1 ft - 262.5 ft) 26 000 kg (57,300 lb) 26 ft 7 in spread (100%) 360°													
Pounds x 1000													
Feet	51.1'	68.7'	86.1'	103.4'	120.8'	138.1'	156.3'	173.5'	191.6'	209.5'	227.4'	245.3'	262.5'
10.0	401.0	335.0											
15.0	312.0	307.0	293.0										
20.0	234.0	230.0	225.0	201.0	175.0								
25.0	177.0	178.0	165.0	158.0	145.0	131.0							
30.0	134.0	139.0	129.0	125.0	116.0	111.0	104.0	84.0					
35.0	100.0	107.0	106.0	101.0	98.0	93.0	85.0	79.0	64.0				
40.0		84.0	87.0	84.0	84.0	78.0	71.0	68.0	62.0	50.0	38.8		
45.0		67.0	72.0	75.0	72.0	67.0	61.0	61.0	52.0	49.0	38.8	31.6	
50.0		55.0	61.0	62.0	62.0	57.0	57.0	53.0	46.0	46.0	38.8	31.6	26.4
55.0			52.0	53.0	53.0	51.0	51.0	45.0	42.4	43.2	38.4	31.6	26.4
60.0			44.0	45.0	45.0	46.0	44.0	39.4	39.4	39.4	37.2	31.4	26.4
65.0			37.6	39.0	40.0	41.2	38.8	34.4	37.0	36.4	33.8	30.6	26.4
70.0			32.4	34.4	36.2	36.2	34.2	30.2	34.0	32.6	30.0	27.4	24.0
75.0				31.0	32.4	32.2	30.0	26.6	30.8	29.0	26.6	24.0	21.4
80.0				28.0	28.4	29.2	26.4	23.2	27.6	26.0	23.6	21.2	18.6
85.0				24.6	25.2	26.6	24.8	19.8	24.8	23.4	20.8	18.6	16.0
90.0				21.8	22.8	23.8	23.2	17.0	22.2	21.0	18.6	16.4	13.8
95.0					20.4	21.2	21.0	14.6	19.6	18.6	16.6	14.4	11.8
100.0					18.2	19.0	18.8	12.4	17.4	16.6	14.6	12.4	10.2
105.0						16.8	16.8	10.4	15.2	14.6	13.0	10.8	8.6
110.0						15.0	15.0	8.6	13.6	12.6	11.2	9.4	7.0
115.0						13.4	13.2	6.8	11.8	11.0	9.6	8.0	5.6
120.0						11.8	11.8	5.4	10.2	9.6	8.0	6.6	4.4
125.0							10.2	4.2	9.0	8.2	6.8	5.2	
130.0							9.2	3.0	7.8	7.0	5.6	4.0	
135.0							8.0		6.6	5.8	4.4		
140.0									5.6	4.8			
145.0									4.6	3.8			
150.0									3.6	2.8			

Load charts





Main boom



15,6 m - 80 m (51.1 ft - 262.5 ft) 16 500 kg (36,400 lb) 26 ft 7 in spread (100%) 360°



Pounds x 1000





Feet	51.1'	68.7'	86.1'	103.4'	120.8'	138.1'	156.3'	173.5'	191.6'	209.5'	227.4'
10.0	396.0	335.0									
15.0	303.0	287.0	250.0								
20.0	218.0	189.0	174.0	154.0	135.0						
25.0	153.0	141.0	133.0	121.0	114.0	105.0					
30.0	107.0	108.0	103.0	100.0	93.0	84.0	77.0	74.0			
35.0	78.0	85.0	84.0	82.0	76.0	69.0	68.0	61.0	54.0		
40.0		66.0	71.0	68.0	63.0	61.0	57.0	51.0	51.0	47.0	38.0
45.0		54.0	58.0	57.0	53.0	53.0	48.0	42.6	46.0	42.4	37.6
50.0		43.8	48.0	48.0	49.0	45.0	41.4	36.2	40.0	37.4	33.8
55.0			40.2	41.8	42.4	40.8	37.2	31.0	35.0	32.6	29.6
60.0			33.4	37.0	37.0	36.8	34.6	26.4	30.6	28.4	25.6
65.0			28.2	32.0	32.4	32.6	30.8	22.8	27.0	25.0	22.0
70.0			24.0	27.4	28.6	28.8	27.4	19.4	23.6	21.8	19.2
75.0				23.6	25.0	25.6	24.4	16.4	20.8	19.0	16.6
80.0				20.4	21.6	22.4	21.6	13.8	18.2	16.6	14.2
85.0				17.6	18.6	19.6	19.2	11.6	16.0	14.4	12.0
90.0				15.2	16.4	17.2	17.0	9.6	14.0	12.6	10.4
95.0					14.2	15.0	14.8	7.8	12.2	10.8	8.6
100.0					12.2	13.0	13.0	6.2	10.6	9.2	7.0
105.0						11.2	11.2	4.6	9.2	8.0	5.8
110.0							9.8	3.2	8.0	6.6	4.6
115.0							8.4	8.2	6.6	5.4	3.4
120.0								7.0	5.6	4.4	
125.0									4.4		
130.0									4.6		
135.0										3.8	



15,6 m - 80 m (51.1 ft - 262.5 ft) 7000 kg (15,400 lb) 26 ft 7 in spread (100%) 360°



Pounds x 1000

Feet	51.1'	68.7'	86.1'	103.4'	120.8'	138.1'	156.3'	191.6'
10.0	394.0	333.0						
15.0	286.0	244.0	205.0					
20.0	178.0	158.0	147.0	133.0	125.0			
25.0	119.0	115.0	107.0	104.0	94.0	80.0		
30.0	80.0	85.0	85.0	80.0	73.0	71.0	64.0	
35.0	57.0	64.0	66.0	63.0	61.0	58.0	52.0	48.0
40.0		50.0	54.0	52.0	52.0	51.0	42.6	40.4
45.0		38.6	43.4	45.0	43.6	42.4	35.0	33.8
50.0		30.2	34.8	37.8	37.0	35.6	29.0	28.4
55.0			28.8	32.0	31.2	30.4	24.2	24.0
60.0			23.4	26.8	26.6	26.0	20.0	20.4
65.0			18.8	22.4	22.8	22.2	16.8	17.2
70.0			15.4	18.8	19.6	19.2	14.0	14.6
75.0				15.6	16.8	16.6	11.4	12.4
80.0				12.8	14.2	14.2	9.2	10.4
85.0				10.6	11.8	12.2	7.4	8.4
90.0				8.6	9.8	10.6	5.6	7.0
95.0					8.0	8.8	4.2	5.6
100.0					6.4	7.2		4.2
105.0						5.8		
110.0						4.6		
115.0						3.4		

15,6 m - 80 m (51.1 ft - 262.5 ft) 0 kg (0 lb) 26 ft 7 in spread (100%) 360°



Pounds x 1000

Feet	51.1'	68.7'	86.1'	103.4'	120.8'	138.1'	156.3'	191.6'
10.0	391.0	331.0						
15.0	259.0	211.0	185.0					
20.0	150.0	137.0	126.0	118.0	105.0			
25.0	96.0	94.0	92.0	85.0	78.0	74.0		
30.0	62.0	70.0	68.0	64.0	63.0	60.0	51.0	
35.0	41.6	51.0	52.0	53.0	50.0	48.0	39.0	36.6
40.0		37.8	40.4	41.6	40.2	38.4	30.6	29.4
45.0		28.0	32.4	33.6	32.6	31.4	24.4	24.0
50.0		20.8	25.6	27.2	26.8	26.0	19.6	19.6
55.0			20.6	22.6	22.2	21.6	15.6	16.0
60.0			16.0	18.4	18.4	18.0	12.2	13.0
65.0			12.4	15.0	15.2	15.0	9.6	10.4
70.0			9.2	12.4	12.6	12.4	7.2	8.2
75.0				10.0	10.2	10.2	5.2	6.4
80.0				7.6	8.2	8.2		4.6
85.0				5.6	6.4	6.4		3.2
90.0				4.0	5.0	5.2		
95.0					3.6	3.8		

THIS CHART IS ONLY A GUIDE AND SHOULD NOT BE USED TO OPERATE THE CRANE.

Working range

Hydraulic offsettable swingaway

263 ft main boom with 39 ft - 69 ft swingaway and 26 ft insert

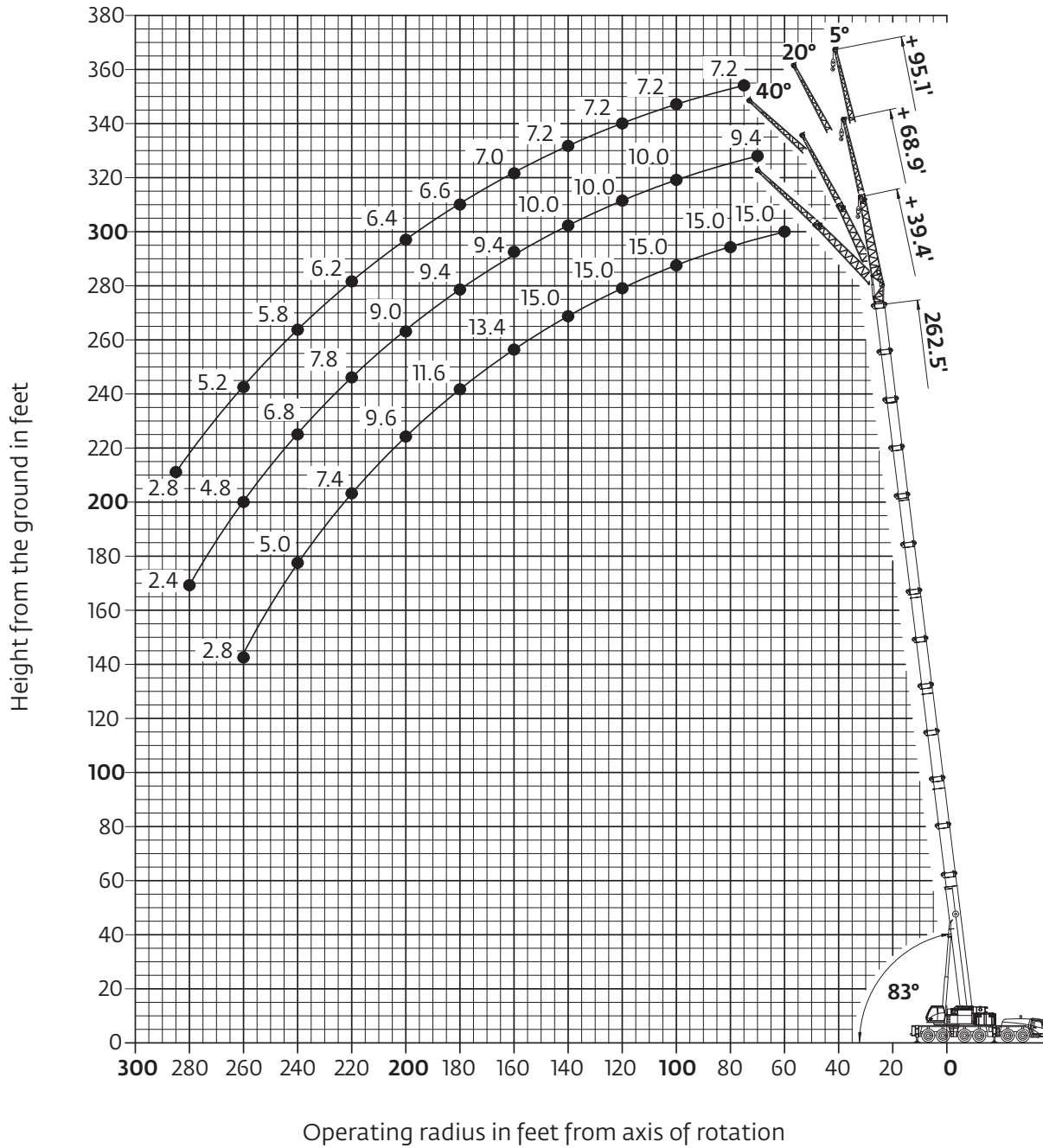

Hook heights shown in the working diagram do not consider loaded boom deflection.

THIS CHART IS ONLY A GUIDE AND SHOULD NOT BE USED TO OPERATE THE CRANE.

The individual crane's load chart, operating instructions and other instructional plates must be read and understood prior to operating the crane.

Load charts

Hydraulic offsettable swingaway

Intermediate angle and loads for luffing

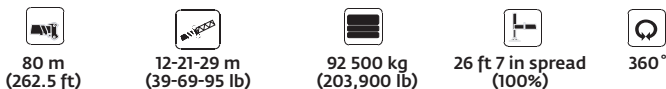

Feet	Pounds x 1000								
	5°	262.5' + 39' 5°-20°	20°-40°	5°	262.5' + 69' 5°-20°	20°-40°	5°	262.5' + 95' 5°-20°	20°-40°
60.0	15.0								
65.0	15.0								
70.0	15.0			9.4					
75.0	15.0	14.8	14.8	9.4			7.2		
80.0	15.0	14.8	14.8	9.4			7.2		
85.0	15.0	14.8	14.8	9.4			7.2		
90.0	15.0	14.8	14.8	9.4	10.0		7.2		
95.0	15.0	14.8	14.8	9.4	10.0		7.2	7.2	
100.0	15.0	14.8	14.8	9.4	10.0	9.0	7.2	7.2	
105.0	15.0	14.8	14.8	9.4	10.0	8.8	7.2	7.2	
110.0	15.0	14.8	14.8	9.4	10.0	8.8	7.2	7.2	
115.0	15.0	14.8	14.8	9.4	10.0	8.8	7.2	7.2	
120.0	15.0	14.8	14.8	9.4	10.0	8.6	7.2	7.0	6.0
125.0	15.0	14.8	14.8	9.4	10.0	8.6	7.2	7.0	6.0
130.0	15.0	14.8	14.8	9.4	10.0	8.6	7.2	6.8	6.0
135.0	15.0	14.8	14.6	9.4	10.0	8.4	7.2	6.8	6.0
140.0	15.0	14.6	14.4	9.4	10.0	8.4	7.2	6.8	6.0
145.0	15.0	14.6	14.0	9.4	9.8	8.4	7.0	6.8	6.0
150.0	14.4	14.2	14.0	9.4	9.4	8.4	7.0	6.6	6.0
155.0	14.0	13.8	13.8	9.4	9.2	8.2	7.0	6.6	6.0
160.0	13.4	13.4	13.4	9.4	9.0	8.2	7.0	6.6	6.0
165.0	13.0	13.0	13.2	9.4	9.0	8.2	6.8	6.6	6.0
170.0	12.4	12.4	12.6	9.4	8.8	8.2	6.8	6.4	6.0
175.0	12.0	12.0	12.2	9.4	8.8	8.2	6.6	6.4	6.0
180.0	11.4	11.4	11.6	9.4	8.8	8.2	6.6	6.4	6.0
185.0	10.8	10.8	11.2	9.4	8.6	8.2	6.6	6.4	6.0
190.0	10.4	10.4	10.6	9.4	8.6	8.2	6.6	6.2	6.0
195.0	9.8	9.8	10.2	9.4	8.6	8.0	6.4	6.2	6.0
200.0	9.2	9.2	9.6	9.0	8.4	8.0	6.4	6.2	6.0
205.0	8.6	8.6	9.0	8.8	8.4	8.0	6.4	6.2	6.0
210.0	8.2	8.2	8.6	8.4	8.4	8.0	6.4	6.2	6.0
215.0	7.6	7.6	8.0	8.2	8.2	8.0	6.2	6.0	6.0
220.0	7.0	7.0	7.4	7.8	7.8	7.8	6.2	6.0	6.0
225.0	6.4	6.4	6.8	7.4	7.4	7.6	6.2	5.8	5.8
230.0	6.0	6.0		7.0	7.0	7.4	6.2	5.8	5.8
235.0	5.4	5.6		6.6	6.6	7.2	6.0	5.8	5.8
240.0	5.0	5.0		6.2	6.2	6.8	5.8	5.8	5.8
245.0	4.4	4.4		5.6	5.8	6.4	5.6	5.6	5.6
250.0	3.6	4.0		5.0	5.2	5.8	5.4	5.4	5.4
255.0	3.2	3.4		4.6	4.8	5.4	5.0	5.2	5.4
260.0	2.6	2.8		4.0	4.2	4.8	4.4	4.6	5.2
265.0				3.6	3.8		4.0	4.2	4.8
270.0				3.2	3.4		3.4	3.6	4.4
275.0				2.8	3.0		3.0	3.2	3.8
280.0				2.2	2.4		2.4	2.6	3.4
285.0								2.2	2.8

THIS CHART IS ONLY A GUIDE AND SHOULD NOT BE USED TO OPERATE THE CRANE.

Grove GMK6350L The individual crane's load chart, operating instructions and other instructional plates must be read and understood prior to operating the crane

Working range

Integrated heavy duty jib

Heavy duty jib 7.5 ft

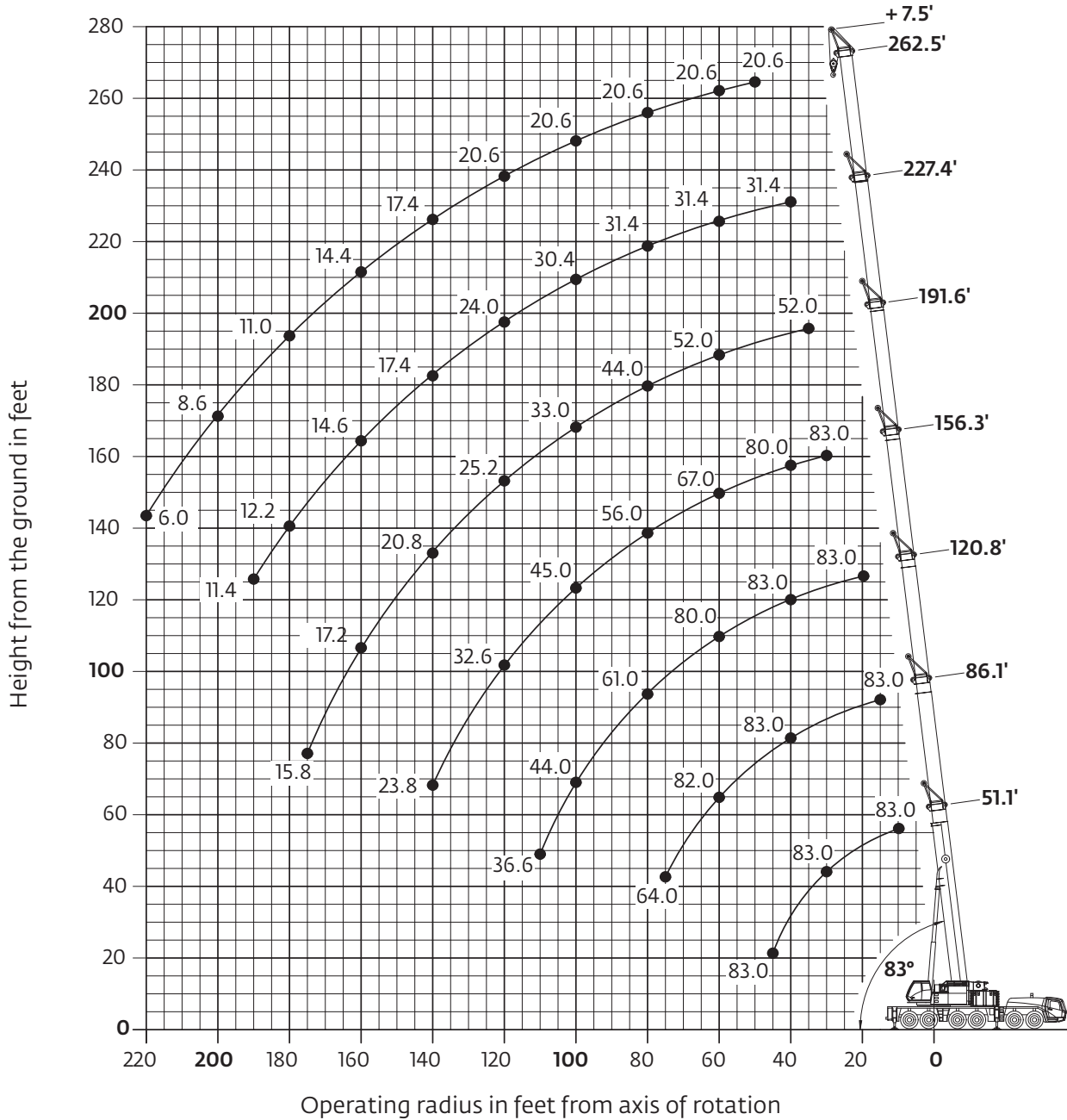

Hook heights shown in the working diagram do not consider loaded boom deflection.

THIS CHART IS ONLY A GUIDE AND SHOULD NOT BE USED TO OPERATE THE CRANE.

The individual crane's load chart, operating instructions and other instructional plates must be read and understood prior to operating the crane.

Load charts

Integrated heavy duty jib

Fixed angle

































Feet	51.1' + 7.5'		86.1' + 7.5'		120.8' + 7.5'		156.3' + 7.5'		191.6' + 7.5'		227.4' + 7.5'		262.5' + 7.5'	
	8°	30°	8°	30°	8°	30°	8°	30°	8°	30°	8°	30°	8°	30°
10.0		83.0												
15.0		83.0												
20.0		83.0		83.0										
25.0		83.0		83.0		83.0								
30.0		83.0		83.0		83.0		83.0						
35.0		83.0		83.0		83.0		83.0		52.0				
40.0	83.0	83.0		83.0		83.0		80.0		52.0		31.4		
45.0	83.0			83.0		83.0		76.0		52.0		31.4		
50.0				83.0		83.0		72.0		52.0		31.4		20.6
55.0				83.0		82.0		69.0		52.0		31.4		20.6
60.0			82.0	82.0		80.0		67.0		52.0		31.4		20.6
65.0			80.0	81.0		75.0		63.0		52.0		31.4		20.6
70.0			73.0	74.0		69.0		61.0		50.0		31.4		20.6
75.0			64.0			65.0		58.0		48.0		31.4		20.6
80.0						61.0		56.0		44.0		31.4		20.6
85.0						58.0		54.0		41.2		31.4		20.6
90.0					52.0	53.0		52.0		38.0		31.4		20.6
95.0					48.0	49.0		49.0		35.4		31.0		20.6
100.0					44.0			45.0		33.0		30.4		20.6
105.0					41.2			41.6		30.6		28.8		20.6
110.0					36.6			38.2		28.8		27.4		20.6
115.0								34.8	35.2	27.0		25.8		20.6
120.0								32.2	32.6	25.2		24.0		20.6
125.0								29.8	30.0	23.4		22.0		20.4
130.0								27.6	27.8	22.0		19.8		20.0
135.0								25.6		20.6		18.2		18.8
140.0								23.8		20.8	19.6	17.4		17.4
145.0										19.6	18.8	16.6		16.6
150.0										18.6	18.2	15.8		15.8
155.0										17.8	17.6	15.2		15.2
160.0										17.2	17.2	14.6		14.4
165.0										16.6		14.0		13.6
170.0										16.4		13.4		12.6
175.0										15.8		12.8		11.8
180.0												12.2		11.0
185.0												11.8		10.4
190.0												11.4		9.8
195.0														9.0
200.0														8.6
205.0														8.0
210.0														7.2
215.0														6.6
220.0														6.0

THIS CHART IS ONLY A GUIDE AND SHOULD NOT BE USED TO OPERATE THE CRANE.

Grove GMK6350L The individual crane's load chart, operating instructions and other instructional plates must be read and understood prior to operating the crane.

Symbols glossary

 Axles	 Counterweight	 Grade	 Gear
 Boom	 Drive	 Heavy duty jib	 Radius
 Boom elevation	 Electrical system	 Hoist	 Rotation
 Boom extension	 Engine	 Hookblock	 Speed
 Boom length	 Extension	 Hydraulic system	 Steering
 Boom nose	 Frame	 Lights	 Suspension
 Brakes	 Fuel tank capacity	 Oil	 Swing
 Cab	 Outriggers	 Outrigger controls	 Tires
			 Transmission

THIS CHART IS ONLY A GUIDE AND SHOULD NOT BE USED TO OPERATE THE CRANE.

The individual crane's load chart, operating instructions and other instructional plates must be read and understood prior to operating the crane.

THIS CHART IS ONLY A GUIDE AND SHOULD NOT BE USED TO OPERATE THE CRANE.

Notes

Regional headquarters

Manitowoc - Americas

Manitowoc, Wisconsin, USA

Tel: +1 920 684 6621

Fax: +1 920 683 6277

Shady Grove, Pennsylvania, USA

Tel: +1 717 597 8121

Fax: +1 717 597 4062

Manitowoc - Europe, Middle East & Africa

Ecully, France

Tel: +33 (0)4 72 18 20 20

Fax: +33 (0)4 72 18 20 00

Manitowoc - Asia Pacific

Shanghai, China

Tel: +86 21 6457 0066

Fax: +86 21 6457 4955

Regional offices

Americas

Brazil

Alphaville

Mexico

Monterrey

Chile

Santiago

Europe, Middle East & Africa

Czech Republic

Netvorice

France

Baudemont

Cergy

Decines

Germany

Langenfeld

Hungary

Budapest

Italy

Parabiago

Netherlands

Breda

Poland

Warsaw

Portugal

Baltar

Russia

Moscow

U.A.E.

Dubai

U.K.

Gawcott

Asia - Pacific

Australia

Brisbane

Melbourne

Sydney

China

Beijing

Xi'an

India

Hyderabad

Pune

Korea

Seoul

Philippines

Makati City

Singapore

Factories

Brazil

Alphaville

China

TaiAn

Zhangjiagang

France

Charlieu

La Clayette

Moulins

Germany

Wilhelmshaven

India

Pune

Italy

Niella Tanaro

Portugal

Baltar

Fânzeres

Slovakia

Saris

USA

Manitowoc

Port Washington

Shady Grove

This document is non-contractual. Constant improvement and engineering progress make it necessary that we reserve the right to make specification, equipment, and price changes without notice. Illustrations shown may include optional equipment and accessories and may not include all standard equipment.



Manitowoc sets the standard for lifting

For almost a century, Manitowoc has been a premier crane manufacturer. Headquartered in Manitowoc, Wis., our manufacturing, service and sales network extends around the world, with operations in the Americas, Europe, the Middle East, Africa and Asia-Pacific. By maintaining this worldwide presence, we are everywhere our customers need us, keeping their operations running and profitable. We're well positioned to understand and serve our customers. That's most of what defines a global industry leader — but just part of what underlines the Manitowoc difference.



Mobile telescopic cranes



Lattice-boom crawler cranes



Boom trucks
and truck-mounted cranes



Tower and self-

innovation



Maniowoc is the single-source solution for any construction lifting need. Dedicated exclusively to this industry, our legacy is providing the most innovative, advanced and comprehensive range of lifting solutions, with products that have long set the standard for excellence worldwide. When customers need Grove mobile telescopic cranes, Maniowoc lattice-boom crawler cranes, Potain tower cranes, National Crane boom trucks, Shuttlelift or YardBoss industrial cranes, or Maniowoc Crane Care parts and services, we deliver.

We back our brands with thousands of the best people in the business, located at more than a dozen manufacturing facilities and over 20 regional sales and support offices around the world. In just over 80 years, we have set the standard for lifting innovation, obtaining more than 150 patents and 500 trademarks.

There is a lot riding on getting the job done right — safety, profitability, even reputations. With so much on the line, everyone must be committed to delivering the best, no matter what. At Maniowoc, our commitment goes even further. We're passionate about exceeding our customers' expectations.



erecting cranes



Maniowoc Crane Care



Maniowoc Finance



CraneSTAR

Mobile telescopic cranes

Groundbreaking. Innovative. Mobile solutions for the world.

Manitowoc cranes are renowned for reliability, return on investment and industry-leading performance. Our Grove line of mobile telescopic cranes ranges in capacity from 8 t – 450 t (8.5 USt – 550 USt), with patented technologies like the MEGATRAK suspension system, the TWINLOCK boom pinning system and the MEGAFORM boom design — all to keep Grove cranes at the top of the market. Producing a full range of Grove all-terrain, rough-terrain and truck-mounted cranes, as well as Shuttlelift and YardBoss industrial cranes, Manitowoc continues to be the mobile crane of choice throughout the world.



Grove GTK1100



Versatility and capacity for multiple applications

GTK
95 t (105 US t) at 112 m (367 ft) height



All-terrain
35 t – 450 t (40 US t – 550 US t)



Truck-mounted
40 t – 90 t (45 US t – 110 US t)



Rough-terrain
30 t – 120 t (30 US t – 130 US t)



Industrial
8 t – 22.6 t (8.5 US t – 25 US t)



GCK
45 t (50 US t)



Grove YB5518



Grove RT540E



Grove GMK5220





Lattice-boom crawler cranes

Pioneering. High performance.

The name that started a passion.

Manitowoc trademark red crawler cranes have an enduring reputation for engineering excellence, high performance and long-lasting reliability. Many of our Manitowoc cranes have more than 40 years of service on the job and are still going strong. We manufacture a full line of hard-working lift cranes and duty-cycle crawler cranes, with capacities ranging from 73 t – 2300 t (80 USt – 2535 USt). Once on board, operators find industry-leading features, including EPIC controls with CANbus technology and the revolutionary FACT quick-assembly system.

Manitowoc 999





The hard-working industry standard



Lattice-boom crawler
73 t – 2300 t (80 USt – 2535 USt)



Attachments
MAX-ER, Luffing jib, RINGER, Fixed jib

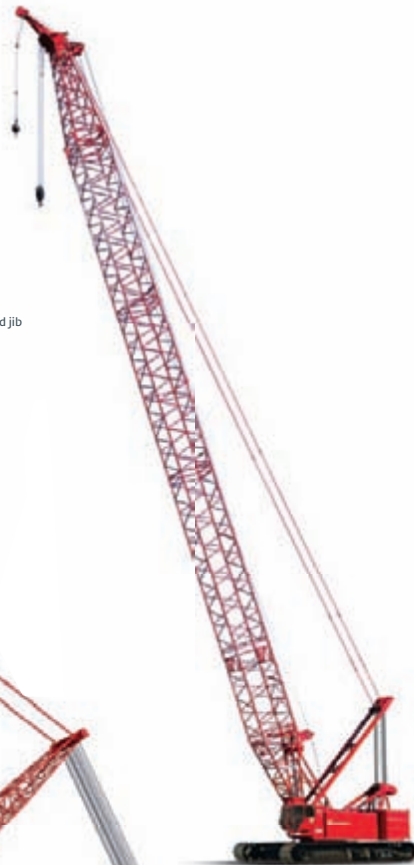

Manitowoc 14000



Manitowoc 31000

Boom trucks and truck-mounted cranes

Rugged. Reliable. Truck-mounted cranes that prove their worth, time after time.

Anyone who values the benefits that rugged boom trucks bring to the jobsite knows the names National Crane, Grove and Dongyue well.

- National Crane offers 12 series of telescoping boom trucks, ranging in capacity from 7,25 t – 50 t (8 USt – 55 USt).
- Grove truck cranes are a popular choice with contractors, thanks to highway-speed travel capabilities and high-capacity booms. With five different models ranging in capacity from 35 t – 90 t (45 USt – 110 USt), Grove offers a truck crane model for any job.
- Dongyue truck cranes are offered in China and are well-known for their strong performance on the road and in lifting. There is a Dongyue product to suit any customer need, with innovations that provide more convenient control and capacities ranging from 8 t – 55 t (9 USt – 60 USt).



Grove TMS9000E



National 900H

NATIONAL CRANE by Casarowoc



FULL SPAN →

Mobility and power wherever they're needed most

National Crane — stand-up controls
7,25 t – 30 t (8 USt – 33 USt)



National Crane — swing cab controls
27 t – 50 t (30 USt – 55 USt)



National 1400H



DongYue GT25-4



Dongyue truck-mounted
8 t – 55 t (9 USt – 60 USt)



Grove truck-mounted
35 t – 90 t (45 USt – 110 USt)



GSK
55 t (61 USt)



Grove TMCS40E

Tower and self-erecting cranes

Dependable. Efficient. Tower cranes that get the job done right.



Potain MDT 368

It is a good chance that those looking up at high-rise jobsites around the world are looking at tower cranes built by Potain. For more than 80 years, Potain top-slewing and self-erecting cranes have been part of the world's most important projects — from skyscrapers, hydroelectric dams and power stations, to schools, apartments and homes. And the reason is clear: They deliver capacity, reach, productivity and precision on jobsites of any size and are especially effective in congested work areas. It all adds up to profitability and return on investment for our customers. Our self-erecting, top-slewing and custom-designed special application cranes range in capacity from 1,3 t – 80 t (1.4 USt – 88.2 USt).

Shown at right: A Potain MDT98 works remotely in a cables configuration in Italy.



Year after year, the industry's best



Potain MR



Fixed-mast-height,
self-erector (Igo)

1,3 t – 4 t (1.4 USt – 4.4 USt)

Variable-mast-height,
self-erector (Igo T, HDT, GTMR)

4 t – 8 t (4.4 USt – 8.8 USt)

Top-slewing topless
(MCT, MDT)

2,5 t – 16 t (2.8 USt – 17.6 USt)

Top-slewing top kit (MD)

10 t – 80 t (11 USt – 88.2 USt)

Top-slewing (MR)

8 t – 32 t (8.8 USt – 35.3 USt)

Potain Igo 30

Manitowoc Crane Care

The best cranes deserve the best service.

Manitowoc Crane Care is the lifting industry's most comprehensive and advanced service and support network. With Crane Care, we offer global access to parts, technical assistance, expert repairs and training — all designed to keep our customers productive for the life of any Manitowoc crane.

Parts

We know how important it is to have the right replacement parts available should our customers need them. To satisfy those needs promptly, we have major parts operations and warehousing facilities around the world, backed by an advanced parts inventory and logistics system, including:

- Global Parts Express 2 (GPX2) — an Internet-based, worldwide distributor parts ordering system with 24/7 availability and service
- Customer Accessible Parts eXpress (CAPX) and D3 electronic catalogs and technical manuals — customers can locate parts quickly from their electronic parts manuals, request pricing and delivery information as well as find technical information about their specific crane



Service and technical support

Our worldwide — yet locally based — network of technicians and support staff are skilled, knowledgeable and ready to serve. No matter when a customer has a need, or where in the world a crane happens to be operating, Crane Care offers local distributors, regional contact centers and rapid response teams offering 24/7 support. Master-level product service engineers can be dispatched within hours to provide on-site damage evaluations and develop step-by-step procedures on how to perform repairs to OEM standards.

EnCORE

With EnCORE from Crane Care, crane owners are assured their equipment will keep performing year after year. EnCORE is available for single components or entire machines, and it encompasses a range of services from repair to rebuild, and from remanufacture to exchange. This ensures that our customers receive maximum value from their original investment, with minimized lifetime operating costs and reduced downtime.

Training

We're dedicated to offering the highest-quality technical service training available anywhere. Every year, we train thousands of customers — from beginner to master level — at Manitowoc Crane Care training centers located around the world. We have our own dedicated classrooms and training aids, including on-site cranes, for practical hands-on learning. In addition, we offer online e-learning training courses for the basics — and as refresher courses when required.

Technical publications

We provide our customers with comprehensive replacement parts and service information, including hardcopy and electronic versions of technical publications such as parts catalogs, operators manuals, service manuals, etc. These publications include the latest engineering design features and updates. They are available in multiple languages and are created at a serial-number-specific level.

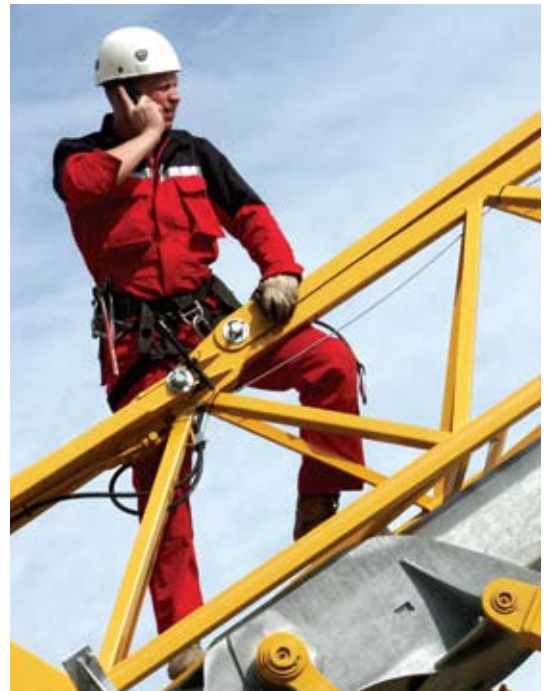

Manitowoc Crane Care provides:

- Contact centers, available 24/7
- Comprehensive training
- Repair and erection services*
- Global access to parts and service
- Technical publications
- Remanufacturing

*Via factory-trained dealers in some areas

Manitowoc Finance

Flexible, convenient financing that puts customers in control.



In addition to designing, building and supporting outstanding cranes, we also offer our customers a wide range of attractive financing and leasing options through Manitowoc Finance. Our team of financing professionals offers industry experience and outstanding customer service and products to help customers meet their business goals and stay competitive.

With Manitowoc Finance, equipment can be acquired with virtually no cash outlay; and unlike traditional lending, our financial products don't affect bank lines of credit. Our customers' capital resources remain intact for times when they need ready access to cash.

We offer special low, competitive rates, and customers can take advantage of flexible financing options and payment schedules that are adaptable to virtually any business need. Our financing agreements can be structured to help them make the best use of their cash reserves and to compensate for seasonal business fluctuations — they can make lower payments when revenue drops or higher payments when business is at its peak. With Manitowoc Finance, we structure our products to put our customers in control.



CraneSTAR

Our investment in our customers' future.



Manitowoc CraneSTAR makes it easier for crane owners to monitor and maintain their equipment. CraneSTAR is the most extensive and innovative OEM-produced crane asset management system available. With its flexible, dual-mode communications capability, GPS and data monitoring and diagnostics, CraneSTAR gives customers near-real-time crane fleet information, no matter where in the world a crane is working.

CraneSTAR enables them to monitor locations and working conditions, plan maintenance and lifting schedules and maximize their company's efficiency, productivity and profitability. They can easily access the CraneSTAR Web site using any Web-enabled device connected to the Internet, and then export data easily into their own business system or program of choice. In addition, customers can monitor and analyze critical data such as engine use, daily productivity and more, thereby enabling them to recognize trends, make more efficient decisions, schedule routine maintenance, and ultimately improve profitability and reduce costs.

Manitowoc Cranes regional headquarters

Americas

2401 South 30th Street
Manitowoc, WI 54220 USA

Tel: +1 920 684 6621

Fax: +1 920 683 6277

1565 Buchanan Trail East
Shady Grove, PA 17256 USA

Tel: +1 717 597 8121

Fax: +1 717 597 4062

Europe, Middle East and Africa

18, rue de Charbonnieres B.P. 173
69132 Ecully Cedex, France

Tel: +33 (0)4 72 18 20 20

Fax: +33 (0)4 72 18 20 00

Asia-Pacific

16F Xu Hui Yuan Building
1089 Zhongshan No. 2 Road (S)
Shanghai 200030 China

Tel: +86 21 6457 0066

Fax: +86 21 6457 4955

www.manitowoc.com

A number of trade and brand names appear in this brochure. For ease of design, these are displayed without their superscript or subscript symbols. The most common names are: MANITOWOC®, NATIONAL CRANE®, MANITOWOC CRANE CARE®, MANITOWOC FINANCE®, GROVE®, POTAIN®, TWIN-LOCK™, MEGATRAK®, MEGAFORM™, EPIC®, VISION CAB™, MAX-ER™ and RINGER®.

CraneSTAR is a service mark of Manitowoc Crane Companies, Inc.



**Discover the Benefits
of Manitowoc Finance**

There are plenty of good reasons to select Manitowoc Finance.

Here are some of the best:

Low rates

Special low rates available on new equipment offered only through Manitowoc Finance. Competitive rates are also available on used equipment.

Hold on to your cash

You can acquire the equipment you need with virtually no cash outlay. In most cases, all you need is a small down payment, or in the case of a lease, one payment in advance.

Keep your existing lines of credit open

Unlike traditional lending, our financial products don't affect your bank lines of credit. Your other capital resources remain intact for times when you need ready access to cash to subsidize growth or meet operational needs.

Be smart — be flexible

From flexible payment schedules to add-on equipment requirements during the life of the equipment, our financial solutions are variable enough to adapt to just about any business situation.

Get the technological edge

Using the latest equipment technology can give you a decided edge in job site efficiencies. But, today's equipment can look obsolete when compared to tomorrow's technology. Why settle for yesterday's level of efficiency? Working through Manitowoc Finance lets you upgrade to new and better equipment anytime during or at the end of the equipment contract term.

Enjoy tax benefits

Depending on the type of finance product you select, your payments may be treated as a fully deductible operating expense or you may depreciate the equipment. For a business needing to shelter income, this can be a huge benefit.





Go with the flow — cash flow!

Our flexible financing options let you schedule your payments to fit fluctuations in cash flow. For businesses tied to seasonal fluctuations, your equipment agreement can be structured to provide seasonal payments when you have income. And, for construction situations that have fluctuating revenue streams, lower monthly payments when revenue drops, and higher payments when your business is at its peak combined with skip payments during those really slow months, may be the best use of cash reserves. Manitowoc Finance can match cash flow to fit your income streams whether annual, semi-annual, quarterly or monthly.

Flexible end-of-term leasing options

We structure all of our products to put you in control. At the end of your agreement you can choose to keep on financing the same crane equipment, finance new Manitowoc equipment or return the equipment. It's up to you. You make the choice.

You can finance just about any piece of Manitowoc or Manitowoc related equipment

Just about any piece of Manitowoc equipment that produces income or saves time and labor can be financed including boom trucks, cranes, and more.

The best reason of all to use Manitowoc Finance...financing with us is quick and easy!

In most cases, just one phone call is all it takes to get the process started. Depending on the transaction size, credit approval can take place in the same day and if you have an existing line of credit, it's even faster.

Plenty of Flexibility and Choice

Manitowoc Finance offers a wide range of financing and leasing programs designed to meet the various business needs of today's customer. Some of our most popular programs are featured below. Take a moment to review them and call your dealer or Manitowoc Finance representative for additional information or with any questions you may have.

Full Payout Loan	Features	Benefits
With a Full Payout Loan, your company has fixed payments over the term of the contract while building ownership equity in the equipment over time.	<ul style="list-style-type: none"> • Level monthly payments • Depreciation and interest deductions claimed by borrower • Payment of equipment over time 	<ul style="list-style-type: none"> • Fixed costs aid budgeting • Borrower takes full advantage of tax benefits • Conserves working capital

Fixed Price Purchase Option	Features	Benefits
With a Fixed Price Purchase Option your company may purchase the equipment for an amount specified at the beginning of the term or return the equipment to Manitowoc Finance.	<ul style="list-style-type: none"> • Level monthly payments • Option to purchase for a fixed price • Payment of equipment over time 	<ul style="list-style-type: none"> • Fixed cost aids budgeting • Operational ownership • Conserves working capital • Pay only for equipment use

Tax or True Lease (Fair Market Value)	Features	Benefits
An operating lease in which your company may purchase the equipment for a fair market value at lease end, extend the lease or return the equipment to Manitowoc Finance.	<ul style="list-style-type: none"> • Level monthly payments • Option to purchase for market price • Lessee may claim payments as expense (subject to advice of counsel or accountant) • Pay only for equipment use • May provide planned replacement 	<ul style="list-style-type: none"> • Fixed costs aid budgeting • Operational ownership • May provide tax benefits and minimize or negate the impact of AMT • Conserves working capital • At term end, equipment may be replaced with new unit • Lower monthly payments

Early Buyout Lease	Features	Benefits
With an Early Buyout Lease, your company experiences the benefit of a Tax or True Lease (FMV) and having a one-time option to purchase the equipment at a stated amount.	<ul style="list-style-type: none"> • Low monthly payments based on FMV residuals • Option to purchase for a fixed price prior to end of lease term • Lessee may claim payments as expense (subject to advise of counsel or accountant) 	<ul style="list-style-type: none"> • Conserves working capital • Pre-determined purchase option • Tax/True Lease treatment • May provide tax benefits and minimize AMT • Option to return equipment at end of lease term

Types of Leases

Accounting Perspective

Capital Lease: A Capital Lease is one that meets any one or more of the four criteria per Financial Accounting Standards Board Statement Number 13 (FASB-13). A Capital Lease is often structured with a bargain purchase option that can range from \$1.00 to some amount below the expected fair market value. A lease in which the present value of the rents exceeds 90 percent of the cost of the equipment would also qualify as a Capital Lease regardless of the purchase option.

A Capital Lease represents nominal ownership for the customer. The cost of the equipment and the lease obligation must be presented on the customer's balance sheet with a Capital Lease.

Operating Lease: An Operating Lease must not meet any of the criteria of FASB-13. An Operating Lease is structured so that the customer uses the equipment for the term of the lease with the options to renew, return the equipment, or purchase it at its fair market value at the end of the lease term. An Operating Lease is basically a "Long-term Rental Agreement" in which the customer obtains the use of the equipment without the risk or benefits of ownership. For accounting purposes these transactions are usually treated as off-balance sheet.

IRS/Tax Perspective

Non-Tax Lease: A lease in which the lessee (customer) is considered by the IRS to be the owner is classified as a Non-Tax Lease. This type of arrangement is like a conditional sales contract. The title to the equipment does not pass to the customer until all required payments have been made, including the purchase option payment.

A Non-Tax Lease often has a purchase option for a predetermined price that is below the expected fair market value. The customer, in such a lease, assumes the risks of ownership and, from a tax standpoint, is considered the owner. The lessor in this type of lease is considered, from a tax standpoint, to have only provided the financing.

Tax Lease/True Lease: From a tax standpoint, a lessee would not be considered the owner of the leased equipment with a Tax or True Lease. The lessor is considered to be the owner of the equipment being leased in a Tax Lease. With a Tax Lease, the lessee is likely to receive lower rental payments because the lessor will receive the benefits of accelerated depreciation in computing his tax liability. For the lessee, all payments on a tax-oriented lease are deductible. To qualify as a Tax Lease, certain IRS guidelines must be met. These guidelines are not the same as the four criteria outlined in FASB-13 used to determine Operating or Capital Lease status from an accounting perspective.

Tax advice should always be sought from a tax professional.

Lease Classification — At a Glance

To summarize the typical tax and accounting classification on leases from the lessee's viewpoint:

	Tax Lease/True Lease	Non-Tax Lease
Tax	Lessee does not take tax benefits	Lessee takes tax benefits
Accounting	Operating Lease	Capital Lease

Please note: These materials are for informational purposes only. The availability of any financing described herein is subject to credit and equipment approval. Nothing herein constitutes tax advice and customers are advised to consult with their tax advisors prior to electing specific rates or options.

Manitowoc Finance: The best way to keep your most valued assets.

Capital starts a business and keeps it growing. Equipment lets the business do its job more efficiently and competitively. Both are essential. Holding on to both of them often requires considerable effort and the right financial solution.

Keep your capital and acquire the equipment you need—by contacting Manitowoc Finance.

An Irresistible Alternative to Ownership

Through Manitowoc Finance you can acquire a significant construction asset without a down payment. You pay for its use out of your operating budget, not from capital reserves. And, at the end of the finance term, you can often buy the equipment for a fraction of the original cost, upgrade to newer technology, extend the finance term or return the equipment to Manitowoc Finance.

The vast majority of American companies, including most of the Fortune 500, utilize some form of equipment financing. This number will continue to grow as more and more businesses discover the vast array of flexible financial solutions available in today's marketplace.

Is Manitowoc Finance right for you?

Which is right for your business, a flexible financing structure or outright purchase? The choice depends.

For example, what will happen to the equipment's value as time goes on? Will it appreciate or depreciate? What will the value be at the end of the economic life cycle? Will the equipment remain functional or become obsolete before the end of its useful life? Can your capital or credit line be better used to leverage your financial returns? Which option will provide the best tax advantage?

If it's equipment that will increase in value and can be acquired without draining your pool of capital, consider buying it. But most equipment needs are not so easily met, and that's where Manitowoc Finance can help.

Manitowoc Finance's team of construction financing professionals offers proven industry experience wrapped around the highest level of service quality. This deep commitment to our customers is the reason why we've been so successful providing flexible financial solutions to the construction industry. Our knowledgeable industry specialists are ready to provide you with the products and services you need to meet your business goals and keep you competitive.



For additional information or questions regarding financing programs or financing in general from Manitowoc Finance, call:

800 377 7262

Call us today to ask us about:

Retail Loans Fair Market Value Leases Fixed Price Purchase Option Leases \$1 Option Leases Rental Fleet Financing
Wholesale Financing Asset Based Lending

We also provide services in these industries to accommodate all your capital needs:

Construction Forklifts Trucks & Trailers Office Equipment Information Technology Telecommunication



Manitowoc Finance

1111 Old Eagle School Road
Wayne, PA 19087
T 800 377 7262
F 866 287 1176

CraneSTAR

Features and benefits



- Dual-mode communication
- User-friendly Web site
- Mapping and geo-fence
- Built-in diagnostic tools
- System integration and more



CraneSTAR. Built by crane professionals — for crane professionals.

Features and benefits

As the most extensive OEM-produced crane asset management system available today, CraneSTAR leads in a new era of data management and planning for crane owners around the world.

CraneSTAR gives you up-to-date crane fleet information, no matter where you or your cranes are located. You can monitor locations and working conditions; plan maintenance and lifting schedules; and maximize your company's efficiency, productivity and profitability.

Rugged construction

CraneSTAR is designed for the tough applications your cranes see on a daily basis. All hardware is weatherproof and meets or exceeds industry environmental standards as well as SAE J1455 specifications for mechanical, electrical and environmental design and use. With its IP67 sealed, compact aluminum enclosure, the hardware is built to withstand harsh environments.

Built-in diagnostic tools

CraneSTAR allows for efficient troubleshooting with six onboard LEDs. A complete user guide is also available to help maintain and troubleshoot all components.



Dual-mode communication

Dual-mode communications provide versatility and flexibility to ensure the system can communicate under varied conditions. Whether over GSM (cell) networks or from satellite (for jobsites beyond the reach of GSM networks), users receive messages in near real time. Antennas have been selected and mounted to optimize signal strength and transmissions.



Advanced communications technology

By using the latest processor and communications technology on the market today, CraneSTAR can function nearly anywhere on the globe. CraneSTAR features a 32-bit processor, GPS, quad-band GSM, and satellite channels. These features provide the best possible options for GSM connectivity around the world.

Easy data retrieval and customization

The easy-to-use CraneSTAR Web site allows you to view your crane data from any PC or Web-enabled device with Internet connection. Users can customize reports so they can analyze data quickly and identify trends in the equipment. This secure Web site provides users a login name and password and ability to control who can access information.

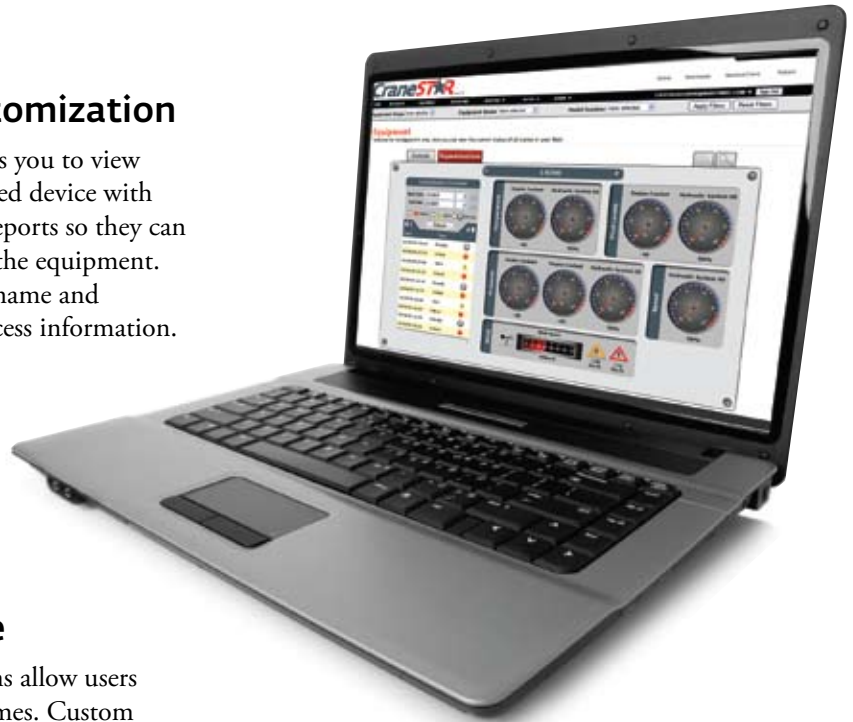

Mapping and geo-fence

The mapping and geo-fence functions allow users to know where the assets are at all times. Custom setup tools and location tracking provide users the opportunity to monitor the fleet on a local, regional, national, or global level. Users can also define a jobsite boundary or fence an entire state or country.

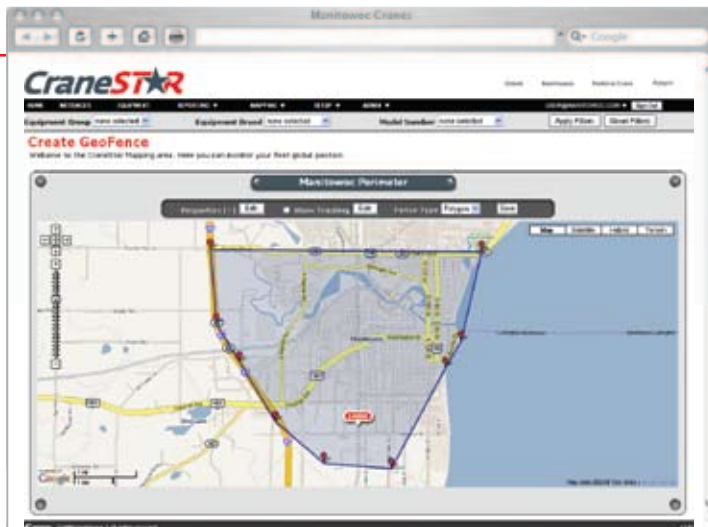

CraneSTAR
EQUIPPED

Standard installation

Available in Q3 of 2009, CraneSTAR will be phased in as standard equipment on many new models of Manitowoc cranes. Please check our Web site for specific model information.

System integration

CraneSTAR helps you manage your assets and your business by easily exporting data from the system database to your business system or any program you choose. With daily and historical data from the asset users can integrate with existing business systems for more accurate reporting and management of assets.

Data monitoring

CraneSTAR reduces costs and improves profitability by helping users monitor critical data, recognize trends, and make more efficient decisions. Users can monitor engine use, location changes, daily productivity, critical systems — and more. By monitoring and reducing idle time, users can save on fuel costs. Users can also monitor equipment for routine service and keep equipment running longer with improved maintenance.



Manitowoc regional headquarters

Americas

Manitowoc Cranes
2401 S. 30th Street
Manitowoc, WI 54220 USA

Tel: +1 920 684 6621

Fax: +1 920 683 6277

Shady Grove Facility
1565 Buchanan Trail East
Shady Grove, PA 17256 USA

Tel: +1 717 597 8121

Fax: +1 717 592 5929

Europe, Middle East and Africa

Manitowoc France SAS
18, rue de Charbonnières B.P. 173
69132 ECULLY Cedex, France

Tél: +33 (0)4 72 18 20 20

Fax: +33 (0)4 72 18 20 00

Asia-Pacific

Manitowoc Shanghai
16F Xu Hui Yuan Building
1089 Zhongshan No. 2 Road (S)
SHANGHAI 200030 China

Tel: + 86 21 6457 0066

Fax: +86 21 6457 4955

www.manitowoc.com

