



TEREX®



TRUCK CRANE
汽车起重机
LT 1130

DATASHEET METRIC
数据表 (公制)

LT 1130



WORKS FOR YOU.™

Key · 关键词汇

3

Dimensions and Specifications · 技术参数

Crane Dimensions · 起重机外形尺寸	4
Specifications · 规格参数	5
Range Diagram · 起升高度	6

Load Charts · 起重量表

7

Technical Descriptions · 技术描述

Lifting Capacity · 起重量	10
Boom and Components · 主臂和零件	10
Jib · 副臂	10
Winch Performance · 起升机构工作速度	11
Crane Boom Function Speeds · 起重臂工作速度	11
Outrigger Function Speeds · 支腿工作速度	11
Outrigger Controls · 支腿操纵	11
Engine and Transmission · 发动机和变速箱	12
Hydraulics · 液压系统	13
Chassis and Components · 底盘及其部件	13
Driver Cab · 驾驶室	13
Operator Cab · 操纵室	13



TEREX®



	Counterweight 配重		Main hoist 主起升机构
	Outrigger 支腿		Auxiliary hoist 副起升机构
	Radius 作业半径		Hoist speed 起升速度
	Main boom 主臂		Cab 驾驶室
	Boom length 吊臂长度		Engine 发动机
	Boom with extension 副臂		Steering 转向
	Boom angle 吊臂角度		Travel speed 行驶速度
	Tip height 臂尖高度		Hydraulics 液压装置
	Hook block 吊钩总成		Transmission 变速箱
	Weight of hook block 吊钩总成重量		Load limiter / Load indicator 力矩限制器
	Slewing / Allowable swinging range 回转/回转范围		Air conditioning / Cab heating 空调/取暖器
	Working speeds 作业速度		Gradeability – road 爬坡度 – 公路
	Working temperature 作业温度		

CRANE DIMENSIONS

起重机外形尺寸

LT 1130

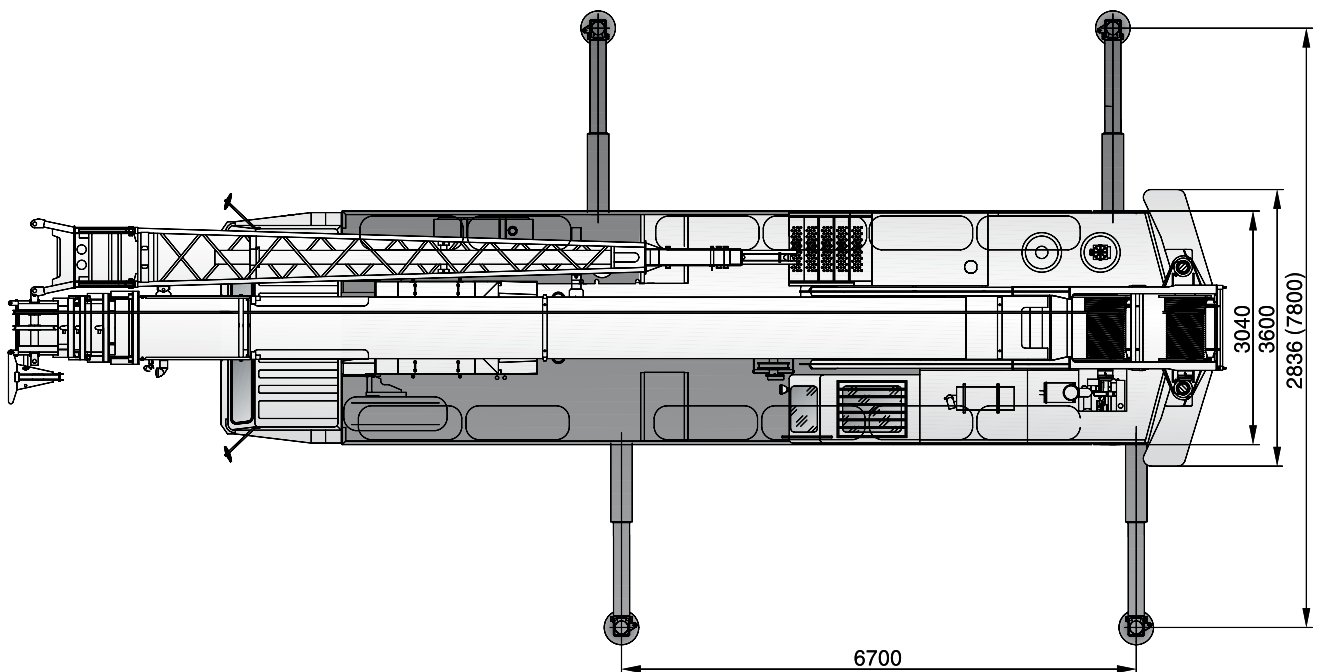
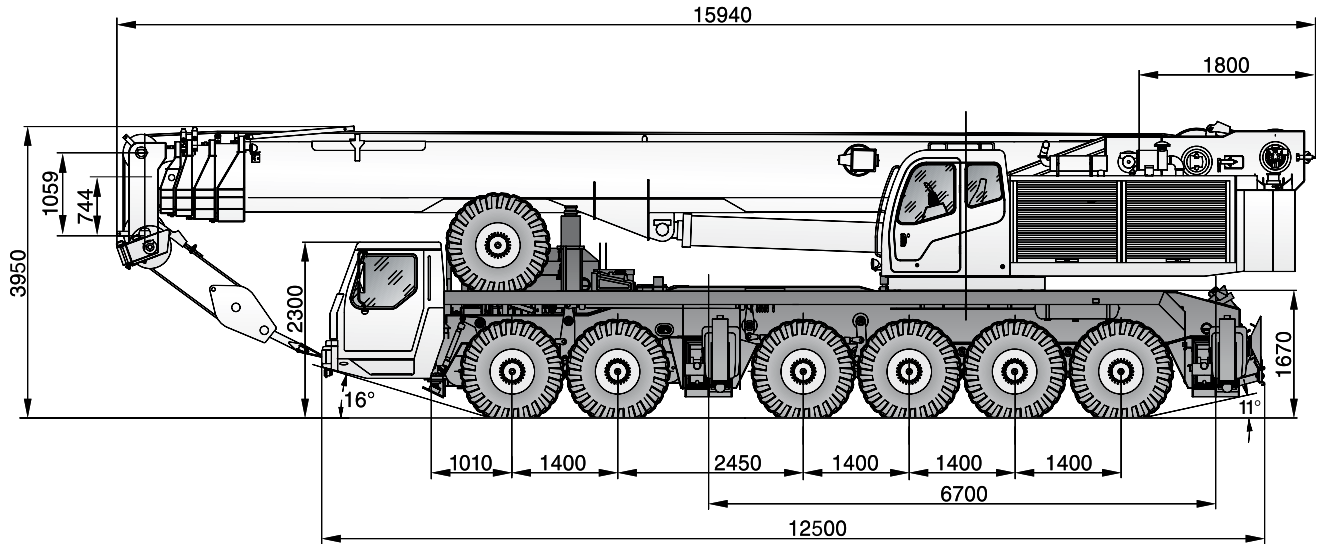

TEREX®



SPECIFICATIONS

规格参数

LT 1130

Crane Weights · 起重机总重量

Gross vehicle weight (GVW) · 车辆总重量 (GVW) 68,500 kg

Axle Configuration · 车桥配置

Steering axles · 转向桥 1, 2 and 3 · 1, 2 和 3

Steering / Drive axle · 转向和驱动桥 4

Drive axles · 驱动桥 5 and 6 · 5 和 6

Axle Loads · 桥负荷

Axles 1 and 2 · 桥 1 和 2 25,600 kg

Axles 2, 3, 4, 5 and 6 · 桥 2, 3, 4, 5 和 6 42,900 kg

Ground Clearances · 通过性参数

Minimum ground clearance · 最小离地间隙 268 mm

Ramp angle · 纵向通过角 31°

Approach angle · 接近角 16°

Departure angle · 离去角 11°

Wheel Base · 轴距

Distance between axle 1 and 2 · 桥 1 和 2 之间的距离 1,400 mm

Distance between axle 2 and 3 · 桥 2 和 3 之间的距离 2,450 mm

Distance between axle 3 and 4 · 桥 3 和 4 之间的距离 1,400 mm

Distance between axle 4 and 5 · 桥 4 和 5 之间的距离 1,400 mm

Distance between axle 5 and 6 · 桥 5 和 6 之间的距离 1,400 mm

Wheel Track · 轮距

Axles 1, 2, 3, 4, 5 and 6 · 桥 1, 2, 3, 4, 5 和 6 2,470 mm

Outrigger Dimensions · 支腿跨距

Longitudinal span · 纵向跨距 6.7 m

Transverse span · 横向跨距 7.8 m

Outrigger Forces · 支腿反力

Maximum counterforce · 最大支反力 909.89 kN

Overall Dimensions · 外形尺寸

(Length x Width x Height) · (长 x 宽 x 高) 15.94 m x 3.05 m x 3.95 m

RANGE DIAGRAM

起升高度

LT 1130

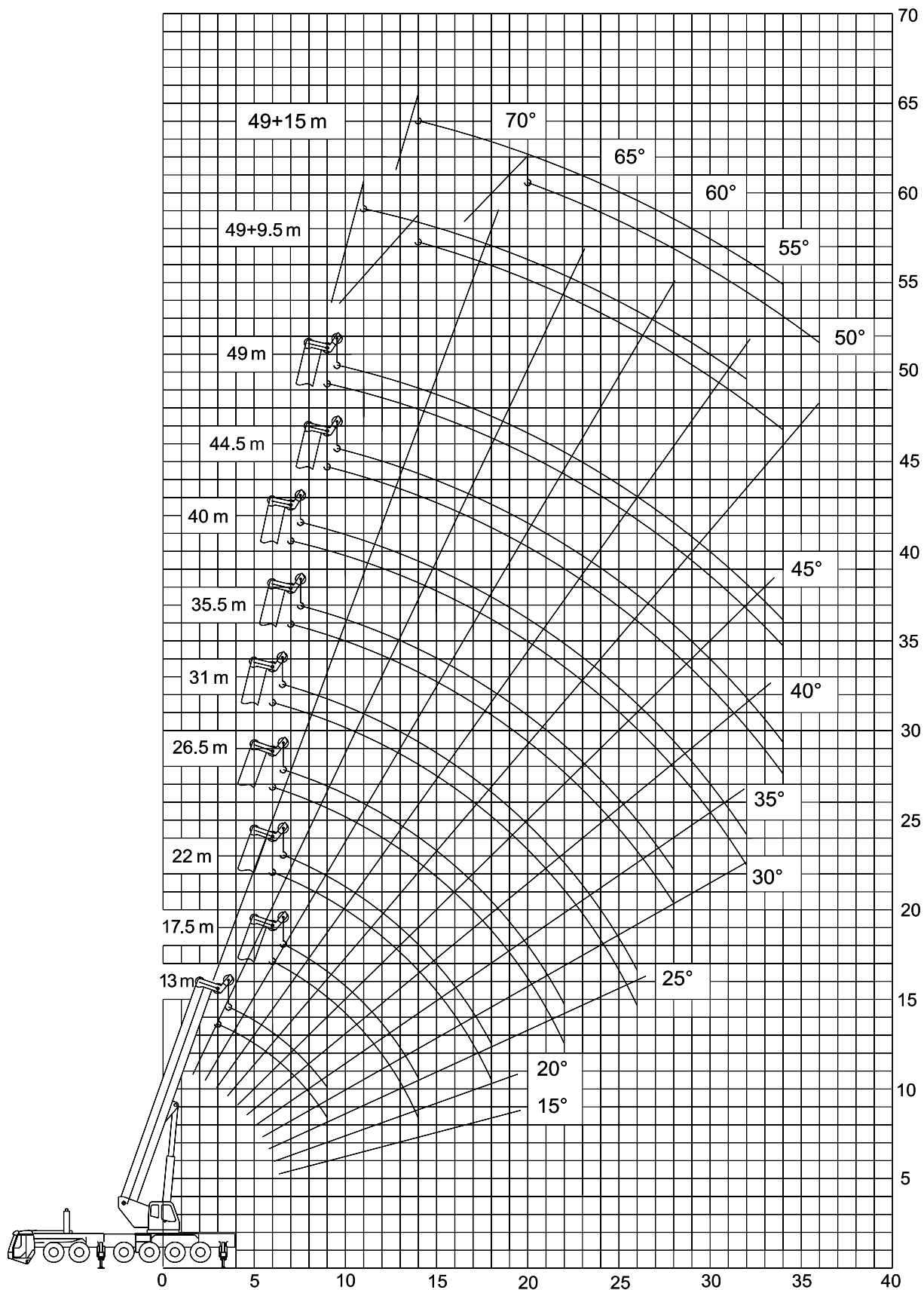

TEREX®



LOAD CHARTS

起重量表

LT 1130

0 t		Fully extended · 支腿全伸 (100%)					360°	
	13.0 m	22.0 m	31.0 m	40.0 m	49.0 m			
m						m		
3	95000	-	-	-	-	3		
3.5	84000	-	-	-	-	3.5		
4	71000	-	-	-	-	4		
5	57000	-	-	-	-	5		
6	48000	43000	29500	-	-	6		
7	41000	37000	27500	24000	-	7		
8	33000	32000	25500	21000	-	8		
9	25000	23500	23500	19000	12000	9		
10	-	18000	19500	17000	12000	10		
11	-	15000	16500	15500	12000	11		
12	-	12000	14000	13500	11000	12		
13	-	10000	12000	12000	10300	13		
14	-	8000	10000	11000	9800	14		
16	-	5400	7000	8200	8500	16		
18	-	3500	5000	6000	6800	18		
20	-	-	3400	4500	5100	20		
22	-	-	2500	3300	3900	22		
24	-	-	1600	2400	3000	24		
26	-	-	-	1700	2000	26		
28	-	-	-	-	1400	28		
30	-	-	-	-	-	30		
min	0°	0°	35°	47°	53°	min		
Parts of Line 倍率	14	7	6	4	3	Parts of Line 倍率		
(t)	130	50	50	50	50	(t)		
kg	1250	600	600	600	600	kg		

Notes · 说明

The values in table are rated lifting capacities of crane on solid ground and in a level state. The working radius in the table are actual radius after load lifting. The values above the bold line are based on crane strength, those below the bold line are based on crane stability. While lifting with boom length of 13 m each section must be fully retracted.

The tabulated load ratings includes weight of hooks, main hook is 1250 kg and auxiliary hook is 260 kg. While the jib is in extension state the rated load capacity lifted by main boom must be reduced by 2800 kg.

When the main hook is at the head of main boom: lifting with jib, the lifting capacities of jib must be reduced by 1250 kg; When working with head pulley, the rated lifting capacities at each section must be reduced by 1250 kg, but max. lifting capacities is 6000 kg; Using main hook when auxiliary hook at the head of pulley of the boom tip, the rated lifting weight of each part of lifting boom should be reduced by 260 kg.

When the fifth outrigger is not in use, no lifting in front of 120° range. On the fifth outrigger, according to the tabulated rated lifting capacities in 360° angle. If the boom length exceeds the specified values, comparing it's capacities with the next longer one's, the load to the lift will be with in the smaller one's. The bottom column in the table lists all min. boom angle of elevation in various boom length. Elevating the boom below the corresponding min. angle of elevation is strictly for bidden.

表中的数据为坚硬地面上水平状态下的额定起重量。表中的作业半径是负载起吊后的实际半径。

粗线上的数据基于起重机的强度，粗线下的数据基于起重机的稳定性。使用 13 m 长的起重臂起吊时，各节臂必须处于完全缩回状态。

表中的负载值包括了吊钩的种类，主钩是 1250 kg，副钩是 260 kg。在副臂处于完全伸出状态时，主臂的起重量必须减去 2800 kg。

当主钩位于主臂头部时：使用副臂起吊时，副臂的起重量必须减去 1250 kg；使用臂端单滑轮作业时，各部分的起重量必须减去 1250 kg，但是最大起重量是 6000 kg；在副钩位于臂端单滑轮的情况下使用主钩时，起重臂各部分的额定起重量必须减少 260 kg。

当不使用第五个支腿时，在 120° 的范围前面不能起吊。在第五个支腿上，根据表中 360° 范围中的额定起重量进行确定。

如果臂长超过的规定的的数据，使用下一个较长的比较其起重量，起重的负荷将为较小的一个。

表中最下面一列列出了主臂各种臂长的仰角。严禁将起重臂变幅到所对应的最小仰角以下。

LOAD CHARTS

起重量表

LT 1130

13.5 t		Fully extended · 支腿全伸 (100%)					360°	
	13.0 m	22.0 m	31.0 m	40.0 m	49.0 m			
m						m		
3	130000	-	-	-	-	3		
3.5	108000	-	-	-	-	3.5		
4	96000	-	-	-	-	4		
5	75000	-	-	-	-	5		
6	59000	43000	29500	-	-	6		
7	50000	37000	27500	24000	-	7		
8	43200	32000	25500	21000	-	8		
9	35500	30000	23500	19000	13000	9		
10	-	27000	19500	17000	12000	10		
11	-	23500	16500	16000	12000	11		
12	-	20700	15500	15000	11400	12		
13	-	17300	15300	13500	10300	13		
14	-	14700	14700	13000	9800	14		
16	-	11000	12700	11600	8500	16		
18	-	8200	10000	10200	7600	18		
20	-	-	7700	8800	7200	20		
22	-	-	6200	7100	6600	22		
24	-	-	4800	5700	6100	24		
26	-	-	3800	4600	5200	26		
28	-	-	-	3600	4500	28		
30	-	-	-	2800	3550	30		
32	-	-	-	2100	2800	32		
34	-	-	-	-	2150	34		
36	-	-	-	-	-	36		
min	0°	0°	28°	33°	44°	min		
Parts of Line 倍率	14	7	6	4	3	Parts of Line 倍率		
(t)	130	50	50	50	50	(t)		
kg	1250	600	600	600	600	kg		

Notes · 说明

The values in table are rated lifting capacities of crane on solid ground and in a level state. The working radius in the table are actual radius after load lifting. The values above the bold line are based on crane strength, those below the bold line are based on crane stability. While lifting with boom length of 13 m each section must be fully retracted.

The tabulated load ratings includes weight of hooks, main hook is 1250 kg and auxiliary hook is 260 kg. While the jib is in extension state the rated load capacity lifted by main boom must be reduced by 2800 kg.

When the main hook is at the head of main boom: lifting with jib, the lifting capacities of jib must be reduced by 1250 kg; When working with head pulley, the rated lifting capacities at each section must be reduced by 1250 kg, but max. lifting capacities is 6000 kg; Using main hook when auxiliary hook at the head of pulley of the boom tip, the rated lifting weight of each part of lifting boom should be reduced by 260 kg.

When the fifth outrigger is not in use, no lifting in front of 120° range. On the fifth outrigger, according to the tabulated rated lifting capacities in 360° angle. If the boom length exceeds the specified values, comparing it's capacities with the next longer one's, the load to the lift will be with in the smaller one's. The bottom column in the table lists all min. boom angle of elevation in various boom length. Elevating the boom below the corresponding min. angle of elevation is strictly for bidden.

表中的数据为坚硬地面上水平状态下的额定起重量。表中的作业半径是负载起吊后的实际半径。

粗线上的数据基于起重机的强度，粗线下的数据基于起重机的稳定性。使用 13 m 长的起重臂起吊时，各节臂必须处于完全缩回状态。

表中的负载值包括了吊钩的种类，主钩是 1250 kg，副钩是 260 kg。在副臂处于完全伸出状态时，主臂的起重量必须减去 2800 kg。

当主钩位于主臂头部时：使用副臂起吊时，副臂的起重量必须减去 1250 kg；使用臂端单滑轮作业时，各部分的起重量必须减去 1250 kg，但是最大起重量是 6000 kg；在副钩位于臂端单滑轮的情况下使用主钩时，起重臂各部分的额定起重量必须减少 260 kg。

当不使用第五个支腿时，在 120° 的范围前面不能起吊。在第五个支腿上，根据表中 360° 范围中的额定起重量进行确定。

如果臂长超过的规定的的数据，使用下一个较长的比较其起重量，起重的负荷将为较小的一个。

表中最下面一列列出了主臂各种臂长的仰角。严禁将起重臂变幅到所对应的最小仰角以下。

LOAD CHARTS

起重量表

LT 1130

13.5 t		Fully extended · 支腿全伸 (100%)		360°	
49 m + 9.5 m		49 m + 15 m			
2.5°		30°		2.5° 30°	
m	kg		kg		m
11	6000	-	-	-	11
12	5700	-	-	-	12
13	5300	-	-	-	13
14	5000	2500	4000	-	14
15	4700	2500	3700	-	15
16	4400	2500	3500	-	16
18	4000	2500	3200	-	18
20	3600	2350	2900	1300	20
22	3400	2250	2650	1250	22
24	3000	2100	2450	1200	24
26	2650	1950	2300	1150	26
28	2300	1800	2000	1100	28
30	1800	1650	1800	1030	30
32	1400	1500	1550	920	32
34	-	1350	1350	830	34
36	-	-	-	780	36
min	55°	55°	56°	57°	min
Parts of Line 倍率	1	1	1	1	Parts of Line 倍率
(t)	6	6	6	6	(t)
kg	260	260	260	260	kg

Notes · 说明

The values in table are rated lifting capacities of crane on solid ground and in a level state. The working radius in the table are actual radius after load lifting. The values above the bold line are based on crane strength, those below the bold line are based on crane stability. While lifting with boom length of 13 m each section must be fully retracted.

The tabulated load ratings includes weight of hooks, main hook is 1250 kg and auxiliary hook is 260 kg. While the jib is in extension state the rated load capacity lifted by main boom must be reduced by 2800 kg.

When the main hook is at the head of main boom: lifting with jib, the lifting capacities of jib must be reduced by 1250 kg; When working with head pulley, the rated lifting capacities at each section must be reduced by 1250 kg, but max. lifting capacities is 6000 kg; Using main hook when auxiliary hook at the head of pulley of the boom tip, the rated lifting weight of each part of lifting boom should be reduced by 260 kg.

When the fifth outrigger is not in use, no lifting in front of 120° range. On the fifth outrigger, according to the tabulated rated lifting capacities in 360° angle. If the boom length exceeds the specified values, comparing it's capacities with the next longer one's, the load to the lift will be with in the smaller one's. The bottom column in the table lists all min. boom angle of elevation in various boom length. Elevating the boom below the corresponding min. angle of elevation is strictly for bidden.

表中的数据为坚硬地面上水平状态下的额定起重量。表中的作业半径是负载起吊后的实际半径。

粗线上的数据基于起重机的强度，粗线下的数据基于起重机的稳定性。使用 13 m 长的起重臂起吊时，各节臂必须处于完全缩回状态。

表中的负载值包括了吊钩的种类，主钩是 1250 kg，副钩是 260 kg。在副臂处于完全伸出状态时，主臂的起重量必须减去 2800 kg。

当主钩位于主臂头部时：使用副臂起吊时，副臂的起重量必须减去 1250 kg；使用臂端单滑轮作业时，各部分的起重量必须减去 1250 kg，但是最大起重量是 6000 kg；在副钩位于臂端单滑轮的情况下使用主钩时，起重臂各部分的额定起重量必须减少 260 kg。

当不使用第五个支腿时，在 120° 的范围前面不能起吊。在第五个支腿上，根据表中 360° 范围中的额定起重量进行确定。

如果臂长超过的规定的的数据，使用下一个较长的比较其起重量，起重的负荷将为较小的一个。

表中最下面一列列出了主臂各种臂长的仰角。严禁将起重臂变幅到所对应的最小仰角以下。

Lifting Capacity · 起重量

	Maximum rated capacity for main hook 主钩额定起重量	130 t
	Maximum rated capacity for auxiliary hook 副钩额定起重量	6 t
	Maximum load moment 最大起重力矩	3.822 kN.m

Boom and Components · 主臂和零件





	Profile 截面形状	Hexagonal 六边形
	Number of sections 节数	5
	Base boom length 基本臂长度	13 m
	Base boom maximum lift height 基本臂最大起升高度	13.61 m
	Base boom maximum working radius 基本臂最大作业半径	9 m
	Fully extended boom length 全伸臂长度	49 m
	Fully extended boom maximum lift height 全伸臂最大起升高度	49.1 m
	Fully extended boom maximum working radius 全伸臂最大作业半径	34 m

Jib · 副臂

	Fully extended boom and jib lengths 全伸臂和副臂的长度	49 m + 15 m
	Fully extended boom maximum lift height with jib 安装副臂最大起升高度	64 m
	Fully extended boom maximum working radius with jib 安装副臂最大作业半径	36 m
	Slewing speed 回转速度	1.6 rpm



Winch Performance · 起升机构工作速度

	 Main hoist – 3rd layer – single rope speed 主卷扬 – 第三层 – 单绳速度	0-110 m/min
	 Auxiliary hoist – 2nd layer – single rope speed 副卷扬 – 第二层 – 单绳速度	0-58 m/min



Crane Boom Function Speeds · 起重臂工作速度

	Elevation – up 起臂	132 sec
	Elevation – down 落臂	163 sec
	Full extension 全伸	182 sec
	Full retract 全缩	125 sec

Outrigger Function Speeds · 支腿工作速度

	 Simultaneous full extension 同步伸出	80 sec
	Simultaneous full retract 同步收缩	65 sec

Outrigger Controls · 支腿操纵

	Dual outrigger controls – LH and RH side 支腿操纵 – 左侧和右侧	Dual control 两侧操纵
	Ambient working temperature 作业温度	-20 °C – +40 °C

Engine and Transmission · 发动机和变速箱

	Chassis Engine: 底盘发动机:	
	Cummins 康明斯	ISXe525 30
	Emission compliance 排放标准	National Exhaust Standard III 国家排放标准 III
	Number of cylinders 缸数	6
	Aspiration 进气	Turbocharged 涡轮增压
	Rated power 额定功率	391 kW @ 1800 rpm
	Maximum torque 最大扭矩	2237 Nm @ 1000 – 1600 rpm
	Estimated fuel consumption per 100 km 100 km 油耗	80 L
	Fuel type 燃油类型	Diesel 柴油
	Fuel tank capacity 燃油箱容积	420 L
Lowest start temperature 最低启动温度	-12 °C	
	Superstructure Engine: 上部设施发动机:	
	Engine model 发动机型号	6BTA 5.9 C180
	Rated power 额定功率	132 kW @ 2200 rpm
Maximum torque output 最大输出力矩	750 Nm @ 1300 rpm	
	Manual gearbox with ZF style air-boosted shifting ZF 气动助力式手动变速箱	Manual air-boosted shift 气动助力式手动变速



Hydraulics · 液压装置

HYDR	Load sensing hydraulic system 负荷感应液压系统	Load sensing 负载感应
	Hydraulic controls: 液压控制: Pilot actuated multi-axis joystick controls 先导控制多轴操纵杆控制	Pilot joystick 操纵杆

Chassis and Components · 底盘及其部件

	Axle drive system 桥驱动系统	12 x 6
	Fifth outrigger for 360° boom operation 360° 作业的第五支腿	Fifth outrigger 第五支腿
	Minimum turning radius 最小转弯半径	14.5 m
	Maximum gradeability 最大爬坡度	35 %
	Maximum traveling speed 最高行驶速度	71 km/h

Driver Cab · 驾驶室

	Adjustable driver seat 可调式司机座椅
	Adjustable steering wheel 可调式方向盘
	Airconditioner and heater 空调和加热装置

Operator Cab · 操纵室

	Adjustable seat 可调式座椅
	Load moment limiter display 载荷力矩限制装置的显示
	Airconditioner and heater 空调和加热装置

www.terexcranes.com

Effective Date: August 2010. Product specifications and prices are subject to change without notice or obligation. The photographs and/or drawings in this document are for illustrative purposes only. Refer to the appropriate Operator's Manual for instructions on the proper use of this equipment. Failure to follow the appropriate Operator's Manual when using our equipment or to otherwise act irresponsibly may result in serious injury or death. The only warranty applicable to our equipment is the standard written warranty applicable to the particular product and sale and Terex makes no other warranty, express or implied. Products and services listed may be trademarks, service marks or trade-names of Terex Corporation and/or its subsidiaries in the USA and other countries. All rights are reserved. Terex® is a registered trademark of Terex Corporation in the USA and many other countries. Copyright 2010 Terex Corporation.

生效日期：2010年8月。产品技术参数和价格如有更改，恕不另行通知。本文档中的图片和/或图纸仅作举例用途。有关正确使用本设备的说明，请参阅合适的操作手册。如果在使用本设备时，未按照操作手册正确操作，可导致严重的人身伤害或死亡。适用于我们设备的唯一保证是适用于特别产品和销售的标准书写保证，特雷克斯不做任何其他保证、表示或暗示。以上所列产品和服务为特雷克斯公司和/或其子公司在美国和其他国家/地区的商标、服务标记或厂商名称。保留所有版权。Terex® 为特雷克斯公司在美国和许多其他国家的注册商标。© 2010，特雷克斯公司版权所有。

Terex Cranes, Global Marketing, Dinglerstraße 24, 66482 Zweibrücken, Germany
Tel. +49 (0) 6332 830, Email: info.cranes@terex.com, www.terexcranes.com

特雷克斯起重机，全球销售，德国 Dinglerstraße 24, 66482 Zweibrücken
电话：+49 (0) 6332 830, Email: info.cranes@terex.com, www.terexcranes.com

Brochure Reference: TC-DS-M-E/C-LT1130 - 08.10
手册参考: TC-DS-M-E/C-LT1130 - 08.10



WORKS FOR YOU.™