

Manitex



TC450

45-Ton (40, 8 mt) TELESCOPIC CRANE
TC450 SERIES PRODUCT GUIDE

CONTENTS

Crane Features	4
Chassis Data	5
Outrigger Extension.....	6
Sub Frame	6
Electrical System.....	6
Intermediate Spread	7
Fully Retracted Spread	7
TC450 Load Chart: Main Boom.....	8
TC450 Boom Diagram	9
TC450 Load Chart: Jib.....	10
Reeving Diagram.....	11
Area of Operation.....	12
LMI Codes	12
Warning, Information & Definitions	13
Technical Descriptions	14
Options	15

Effective Date: September 1, 2015

This document is non-contractual. This document is supplied for reference use only. We are constantly making improvements to our products and reserve the right that specification, equipment, and prices are all subject to change without notice or obligation.

The photographs, and/or images in this document are for illustrative purposes only and may include optional equipment and accessories and may not include all standard equipment.

Refer to the appropriate Operator's Manual and Load Charts for instructions on the proper use of this equipment to determine allowable crane lifting capacities, assembly and operating procedures. Failure to follow the appropriate operator's manual or load chart(s) when using our equipment or to otherwise act irresponsibly may result in serious injury or death.

The only warranty applicable to our equipment is the standard written warranty applicable to the particular product and sale. Manitex makes no other warranty, expressed or implied.



















Products and services listed may be trademarks, service marks or trade-names of Manitex International and/or its subsidiaries in the USA and other countries.

















All rights are reserved. Manitex® is a registered trademark of Manitex International, Inc. in the USA and many other countries.

Copyright 2013 Manitex Inc. Manitex Inc, Georgetown Texas, 78626



KEY

	Operator aids
	Cab
	Heating / Air conditioning
	Controls
	Hoist speed
	1 - Main hoist 2 - Auxiliary winch 3 - Recovery winch
	Rope length
	Rope - standard/optional
	Rope diameter
	Permissible line pull
	Maximum line pull
	Slewing / Allowable slewing range
	Slewing gears
	Slewing brake
	Outriggers / Lifting on outriggers
	2-Person man basket
	Counterweight
	Radio remote control

	Hook block
	Distance from hook to head sheave pin
	Hook and ball
	Hydraulics
	Boom elevation angle
	Max. boom length with extension
	Boom with extension retracted
	Boom angle
	Telescoping mode
	Working radius
	Boom length
	Hydraulic actuated boom
	Full power mechanical synchronized
	Boom head / Hook block dimension
	Main boom with auxiliary head
	Tip height



THE TC450 SERIES TELESCOPIC CRANES

Versatile. Affordable. User friendly.

The TC450 series telescopic cranes are built to meet the wide-ranging needs of owner operators who may use it for residential construction one day and bridge work the next. No matter what the task, the 45-ton line of telescopic crane is designed to get you to the job and on the job quickly.

With it, you can:

- ◆ Travel to and from job sites at highway speed on a commercial chassis
- ◆ Set up quickly with radio outrigger controls
- ◆ Operate comfortably and confidently in its tilttable cab

Other features include:

- ◆ 45-ton capacity @ 7 ft. radius
- ◆ 5-section proportional boom
- ◆ Optional telescopic jib
- ◆ 152' (46,3 m) maximum boom tip height
- ◆ Out-and-down outriggers

NEW COMBINED RADIO REMOTE



RADIO CONTROLS

One control to operate the outriggers, winch controls and the boom.

RADIO OUTRIGGER CONTROLS

Operate the outriggers remotely, with a clear view of the machine, using radio outrigger controls we call ROC Solid.

CAB UPGRADES

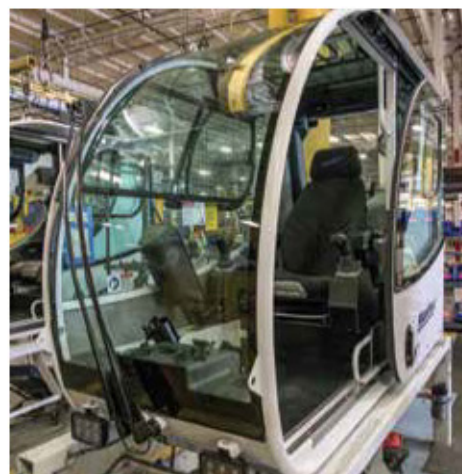

All cabs now come equipped with Heat and AC with 200% more air flow. Adjustable cab tilt speed and crane functions. USB ports for quick software updates or phone charging.

More leg space and only one display unit needed for both crane and chassis operations.

TELEMATICS



A modem has been added to the crane PLC system to aid troubleshooting machines in the field. Crane software updates can now be uploaded to the machine without having to send a technician to the field! GPS ready for tracking through the Manitex web portal.

TC450 SERIES CHASSIS DATA

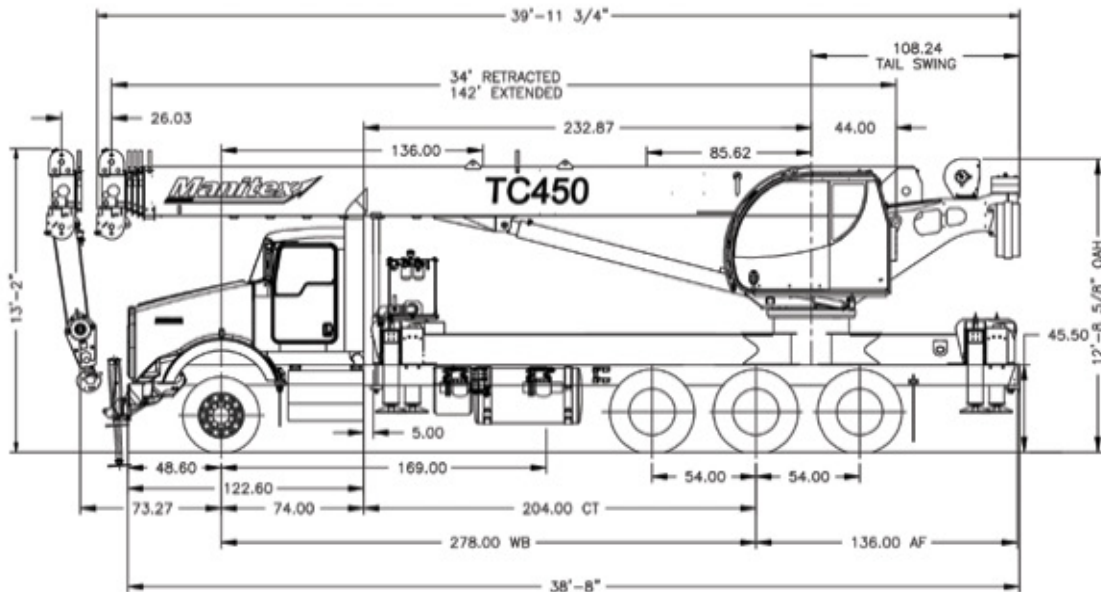

OPERATOR AIDS



45124S is externally routed A2B cable with function cut-offs for overload protection. Color graphic display unit for system monitoring.

CHASSIS DATA

S Models	TC450
Wheel Base (WB)	278 in. (7,061 mm)
Cab to Tandem (CT)	204 in. (5281.6 mm)
Frame section modulus at 180° area of operation*	27.0 in ³ , 110,000 psi, 758,422 kPa
Cab to End of Frame (EOF)	316 in. (8026 mm)
Nominal Frame Width	34 in. (864 mm)

* Frame section modulus at 360° area of operation requires front bumper stabilizer.

CRANE WEIGHTS

Model	TC450
Crane with cab	40,738 lb. (18,479 kg)
Aluminum Platform	621 lbs. (282 kg)
Tele Jib	1620 lb. (735 kg)

TRUCK AXLE WEIGHTS

S Models	TC450
Front axle (GW)	20,000 lb. (9,790 kg)
Rear axle	40,000 lb. (19,580 kg)
Tag Axle Rating	12,500 lb 5669kg
Min. truck axle W - Front **	9,000 lb. (4082kg)
Min. truck axle W - Rear **	9,600 lbs. (4354 kg)

** Minimum class weight is required to meet 85% stability requirements. Chassis data is general - not for engineering. Some dimensions depend on truck selection.

OUTRIGGERS

Full Extension

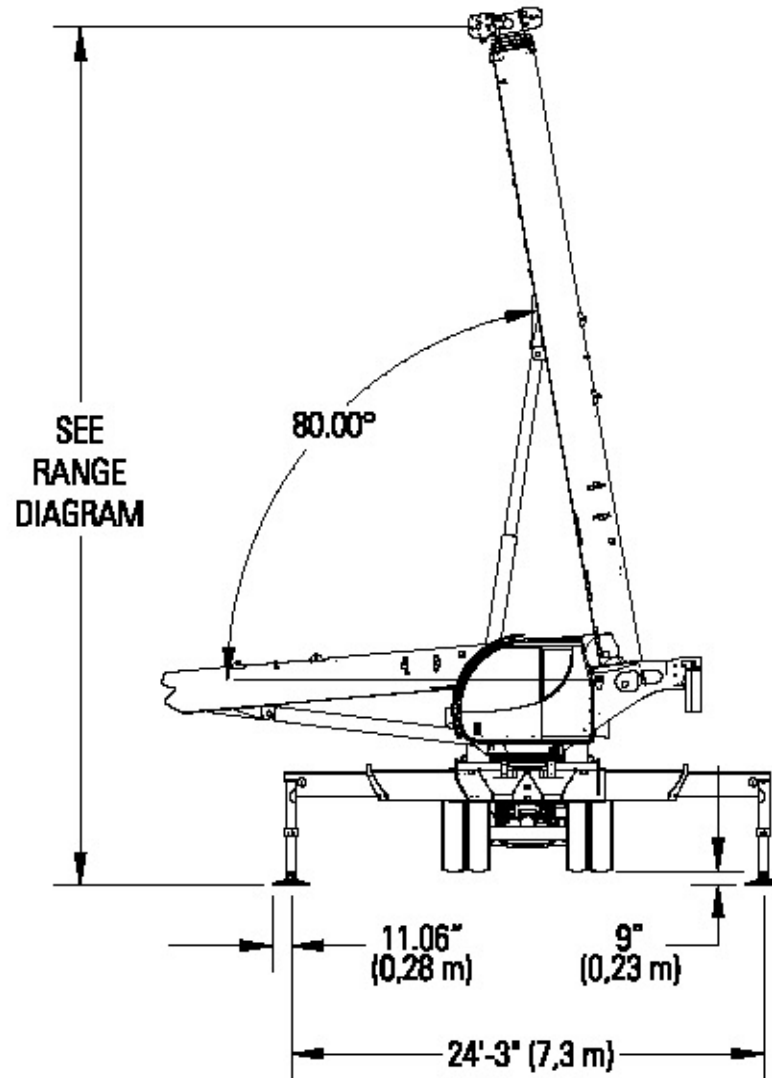

SUB FRAME

- ◆ Pedestal sub-frame and stabilizers are mounted to chassis by threaded rods and clamp plates
- ◆ Sub-frame: Torsion resistant, rigid 4-plate design mounted under crane full length of truck frame
- ◆ Rear under-ride protection: Standard on factory mounted cranes

ELECTRICAL SYSTEM

- ◆ State-of-the-art, weather-resistant components throughout
- ◆ Hermetically sealed enclosure includes power in relays and circuit status LEDs
- ◆ 12-24 Volt Capability

Data published herein is intended as a guide only. Crane operation is subject to machine specific load charts and information.



OUTRIGGERS

Intermediate Spread

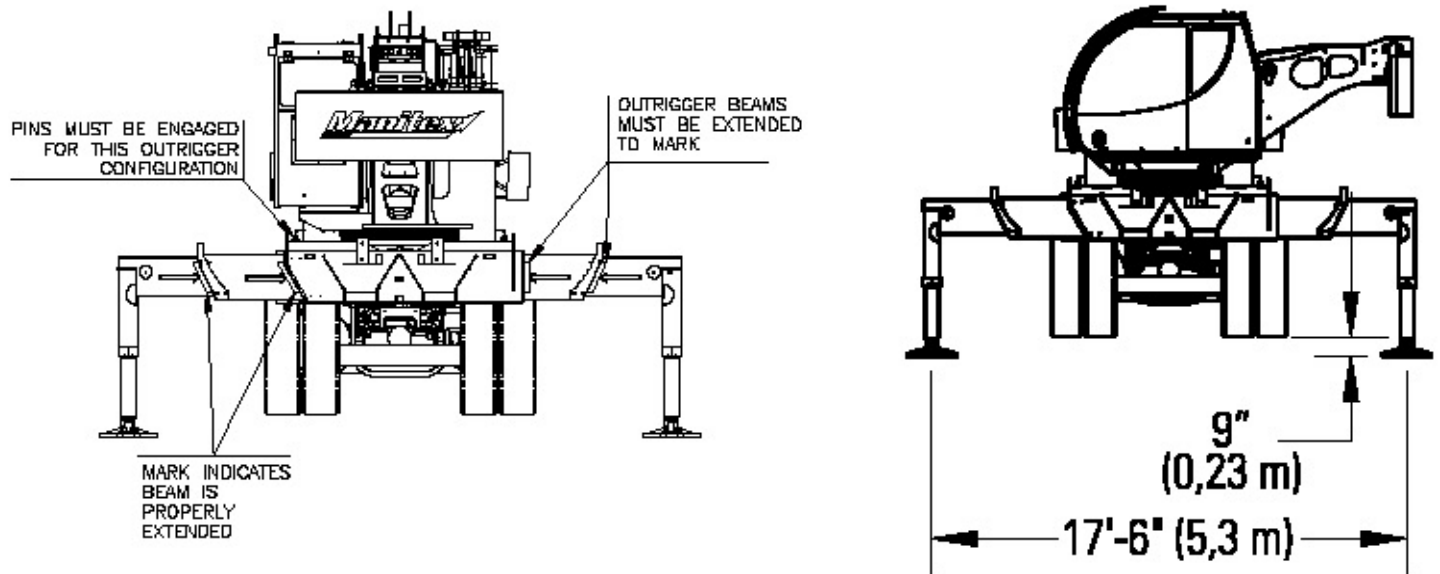

Fully Retracted Spread

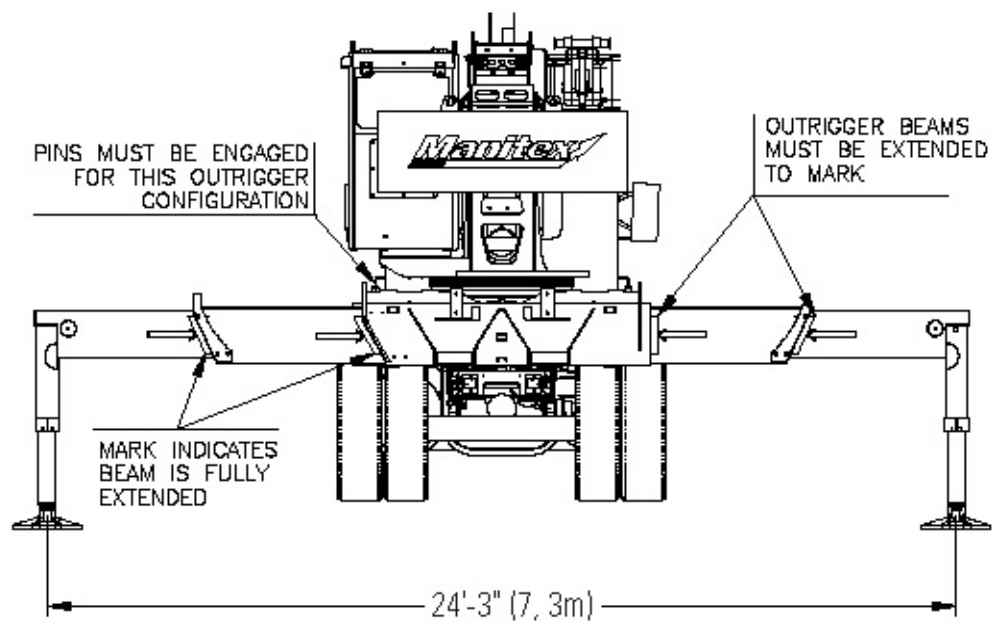

TC450 LOAD CHART: Main Boom & Jib

Lifting Capacities 5 section Boom 142 ft. 43,3 m

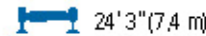

Full Outrigger Extension

MAIN BOOM RATED LOADS LMI CODES 3

Load radius A°	34 ft.		47 ft. (A)		61 ft. (B)		74 ft. (C)		88 ft. (D)		101 ft. (E)		115 ft. (F)		128 ft. (G)		142 ft. (H)		Load radius A°
	(deg)	Load Capacity (lbs.)	(deg)	Load Capacity (lbs.)	(deg)	Load Capacity (lbs.)	(deg)	Load Capacity (lbs.)	(deg)	Load Capacity (lbs.)	(deg)	Load Capacity (lbs.)	(deg)	Load Capacity (lbs.)	(deg)	Load Capacity (lbs.)	(deg)	Load Capacity (lbs.)	
7	73	90,000																	7
8	71	80,000	77	42,000															8
10	67	70,500	74	42,000	79	42,000													10
12	64	62,100	72	42,000	77	42,000	80	34,060											12
15	58	49,450	68	42,000	74	40,960	78	32,860	80	23,430									15
20	47	35,640	61	36,240	69	36,570	74	30,970	77	21,610	79	16,510							20
25	33	27,160	54	27,810	64	28,140	70	28,310	74	19,730	76	15,160	79	13,500					25
30	9	19,390	46	22,100	58	22,450	65	22,630	70	18,300	74	13,960	77	12,420	79	10,000	80	8,000	30
35			36	17,980	52	18,360	61	18,530	67	17,060	71	12,860	74	11,420	76	9,800	78	7,800	35
40			23	14,840	46	15,250	56	15,440	63	15,570	68	11,860	71	10,540	74	9,400	76	7,600	40
45					39	12,820	51	13,020	59	13,150	64	10,990	69	9,550	72	8,800	74	7,350	45
50					30	10,850	46	11,070	55	11,210	61	10,200	66	8,870	69	8,300	72	7,050	50
55					18	8,870	40	9,170	51	9,340	58	9,430	63	8,260	67	7,900	70	6,800	55
60							33	7,610	47	7,790	54	7,890	60	7,680	64	7,450	68	6,500	60
65							24	6,330	42	6,520	50	6,630	57	6,710	62	6,770	66	6,100	65
70									36	5,480	46	5,590	54	5,670	59	5,720	64	5,700	70
75									30	4,590	42	4,700	51	4,790	56	4,840	61	4,880	75
80									21	3,820	37	3,950	47	4,030	54	4,090	59	4,130	80
85											32	3,300	43	3,360	51	3,440	56	3,480	85
90											25	2,720	39	2,810	47	2,870	54	2,910	90
95											17	2,200	35	2,310	44	2,370	51	2,410	95
100													30	1,870	40	1,930	48	1,970	100
105													23	1,460	36	1,530	45	1,580	105
110													12	1,090	32	1,170	42	1,220	110
115															26	840	38	900	115
120																			120
		840 lbs.		560 lbs.		450 lbs.		360 lbs.		330 lbs.		290 lbs.		260 lbs.		230 lbs.		210 lbs.	

NOTES:

- ◆ Loads based on crane on outriggers
- ◆ All "on outriggers" loads are based on 85% tipping
- ◆ Loads above heavy line are based on structural rating
- ◆ Loads below heavy line are based on tipping rating

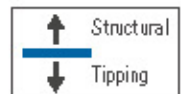

Data published herein is intended as a guide only. Crane operation is subject to machine specific load charts and information.

TC450 BOOM DIAGRAM

RANGE DIAGRAM - FULLY EXTENDED OUTRIGGER CONFIGURATION -

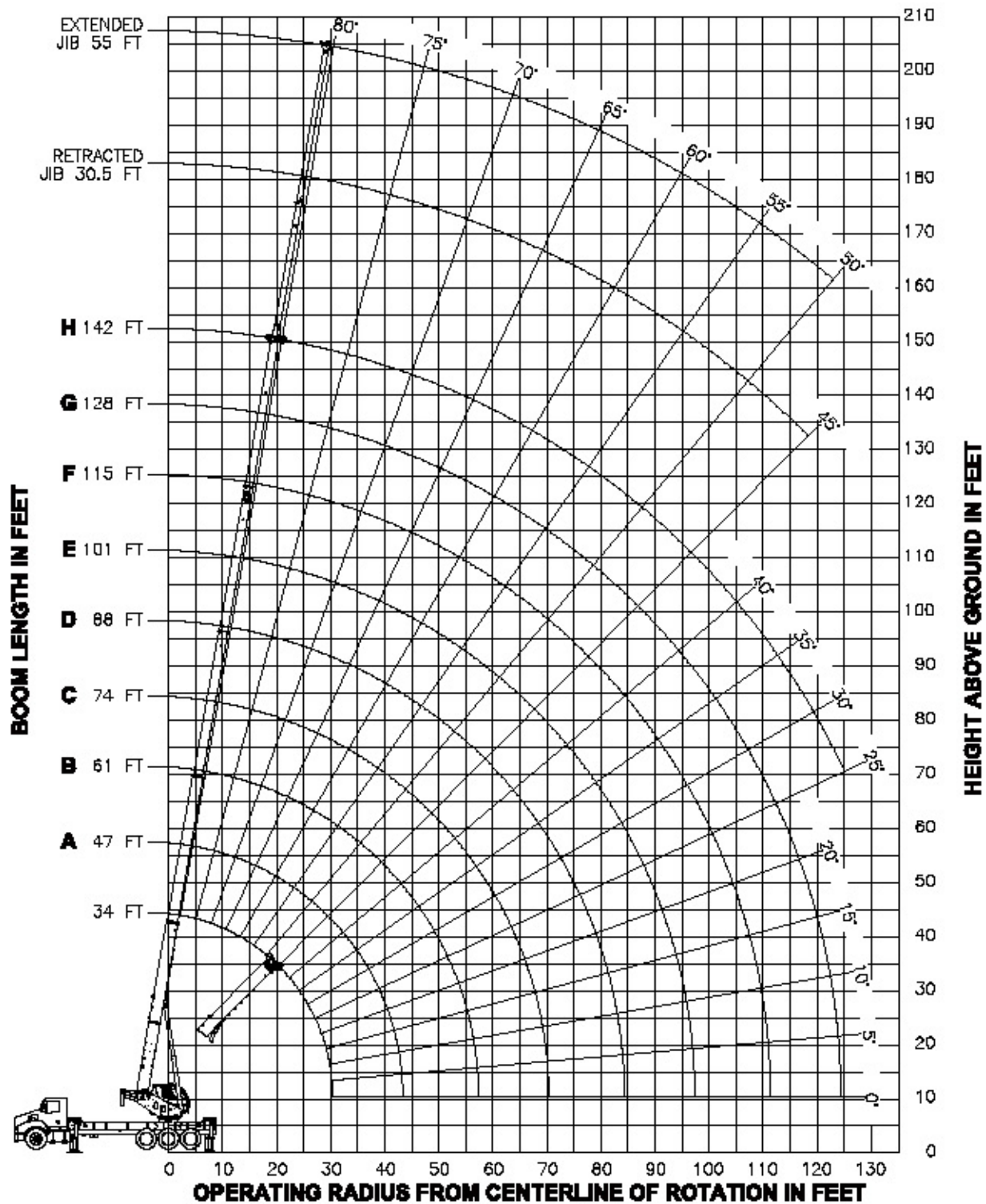



Data published herein is intended as a guide only. Crane operation is subject to machine specific load charts and information.

TC450 LOAD CHART: Jib

Lifting Capacities 5 section Boom 142 ft. 43,3 m

 24' 3" (7.4 m)

Full Outrigger Extension

JIB LOAD CAPACITIES					
	LMI CODE 7		LMI CODE 13		
	30.5 ft. Tele Jib		55 ft. Tele. Jib		
Load radius ∠ (deg)		Load Capacity (lbs.)		Load Capacity (lbs.)	Load radius ∠ (deg)
30					30
35	79.0	3,450			35
40	77.2	3,400	79.4	2,500	40
45	76.1	3,350	78.0	2,250	45
50	74.7	3,330	76.7	2,250	50
55	73.2	3,180	75.6	2,250	55
60	71.5	2,920	74.5	2,250	60
65	69.4	2,760	73.1	2,100	65
70	68.0	2,610	72.1	1,970	70
75	66.3	2,470	70.5	1,860	75
80	64.5	2,340	68.7	1,760	80
85	62.9	2,220	67.1	1,670	85
90	61.1	2,110	66.1	1,590	90
95	59.4	2,010	64.6	1,530	95
100	57.4	1,920	62.9	1,460	100
105	54.5	1,550	61.4	1,400	105
110	52.7	1,190	60.2	1,340	110





NOTES:

- ◆ Loads based on crane on outriggers
- ◆ All "on outriggers" loads are based on 85% tipping
- ◆ Loads above heavy line are based on structural rating
- ◆ Loads below heavy line are based on tipping rating

Data published herein is intended as a guide only. Crane operation is subject to machine specific load charts and information.

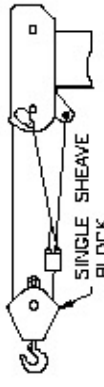
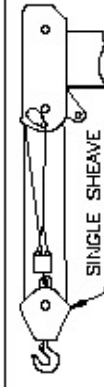
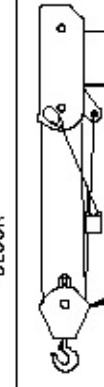
REEVING DIAGRAM

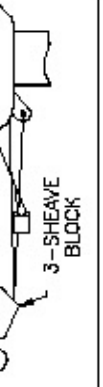
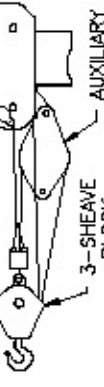
ALLOWABLE LINE PULL								WARNING
1 PART LINE	2 PART LINE	3 PART LINE	4 PART LINE	5 PART LINE	6 PART LINE	7 PART LINE	8 PART LINE	
								<p>ANTI-TWO-BLOCK SYSTEM MUST BE IN GOOD OPERATING CONDITION BEFORE OPERATING CRANE.</p> <p>REFER TO THE OWNER'S MANUAL.</p> <p>KEEP AT LEAST 3 WRAPS OF LOAD LINE ON THE DRUM AT ALL TIMES.</p>
9500 LBS	19000 LBS	28500 LBS	38000 LBS	47500 LBS	57000 LBS	66500 LBS	76000 LBS	
10000 LBS	20000 LBS	30000 LBS	40000 LBS	50000 LBS	60000 LBS	70000 LBS	80000 LBS	5/8" 6 X 25 IWRC (3.5:1 SF) - 36000 LBS MIN BREAKING STRENGTH

Deductions from rated loads for load handling devices supplied by Manitex

Auxiliary block	50 lbs. (22.7 kg)
Overhaul ball	See overhaul ball mfr. nameplate
Load blocks	See load block mfr. nameplate
Hose reel	140 lbs.
Swing around jib (stowed)	See load chart

WARNING: Lifting off the main boom point while the jib is erected is not intended nor approved.

AREA OF OPERATION

full length subframe shown. Short subframe configuration requires a front bumper stabilizer.

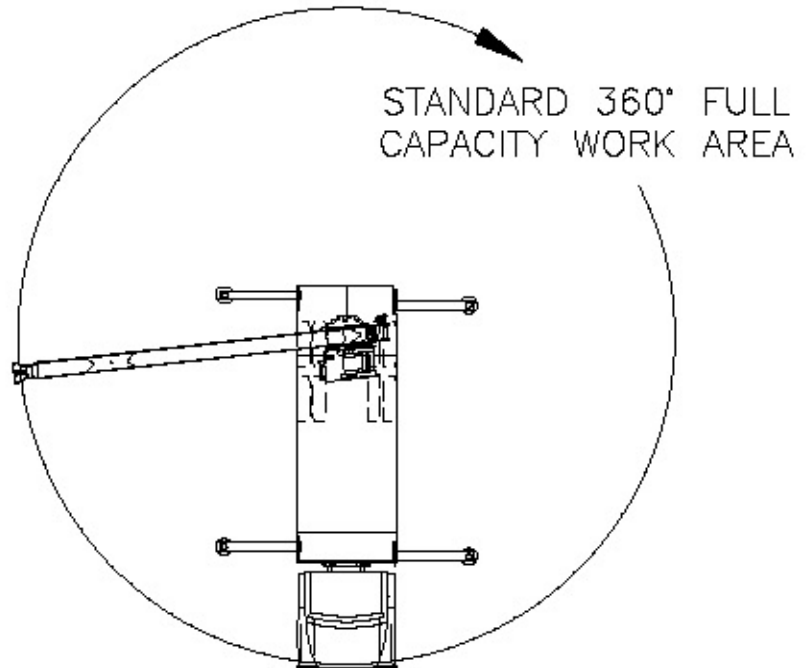

LMI OPERATING CODES

Code	Crane Configuration	Outrigger Configuration
#3	Main Boom	Fully Extended
#7	Telescopic Jib-Retracted	Fully Extended
#13	Telescopic Jib-Extended	Fully Extended
#25	Personnel Lifting Platform on Main Boom	Fully Extended
#26	Personnel Lifting Platform on Telescopic Jib-Retracted	Fully Extended
#29	Personnel Lifting Platform on Telescopic Jib-Extended	Fully Extended
#4	Main Boom	Intermediate



Data published herein is intended as a guide only. Crane operation is subject to machine specific load charts and information.

Warning

1. The operator must read and understand the owner's manual before operating the crane.
2. Positioning or operation of crane beyond areas shown on these charts is not intended or approved except where specified in owner's manual.
3. Loaded boom angles at specified boom lengths give only an approximation of the operating radius. The boom angle before loading should be greater to account for deflections. Do not exceed the operating radius for rated loads.
4. The operating radius shown in the jib rating chart is for fully extended boom only. When boom is not fully extended, use only loaded boom angle to determine load rating of jib.
5. For boom angles not shown on jib load rating chart, use rating of next lower boom angle.
6. For boom lengths not shown, use rating of next shorter or longer boom length, whichever is less. For radii not shown, use rating of next longer radius.
7. Crane load ratings on outriggers are based on freely suspended loads with the machine leveled and standing on a firm uniform supporting surface. No attempt shall be made to move a load horizontally on the ground in any direction.
8. Practical working loads depend on supporting surface, wind, and other factors affecting stability such as hazardous surroundings, experience of personnel, and proper handling, all of which must be taken into account by the operator.
9. The maximum load which may be telescoped is limited by hydraulic pressure, boom angle, and boom lubrication. It is safe to attempt to telescope any load within the limits of the load rating chart. Boom must be fully retracted against boom stops at all times when lifting minimum boom length capacity loads.
10. Lifting off the main boom point while the swing around jib is erected is not intended or approved.

Information

1. Deductions must be made from rated loads for stowed jib, optional attachments, hooks, and load blocks (See deduction chart on page 8). Weights of slings and all other load handling devices shall be considered a part of the load.
2. Load ratings above the blue line are structurally limited capacities. Load ratings below the blue line are stability limited capacities and do not exceed 85% of tipping.

Definitions

1. Operating radius is the horizontal distance from the axis of rotation to the center of the vertical hoist line or tackle with load applied.
2. Loaded boom angle as shown in the column head by  is the included angle between the horizontal and longitudinal axes of the boom base after lifting rated load at rated radius.

TECHNICAL DESCRIPTIONS

Boom



Boom lengths: Proportional boom

- ◆ 5-section 142 ft.
- ◆ 3-Sheave Load Quick Reeve boom point
- ◆ 2-Sheave Idler boom point

Self lubricating slider pads



Max. tip height 45142S: 152 ft. (46,3 m)



Boom angle (min/max): -6°/ 80°

Rotation



Ball-bearing swing circle with external gear
Double-reduction planetary gearbox driven by hydraulic motor



Slewing brake: Spring-applied pressure released automatic brake
Free Swing and Non-Free Swing selection from the operator's keypad.



Slewing speed: 1.5 - 2 rpm. (nominal)
Boom rotation: 360° continuous

Outriggers



Outriggers: Out-and-down style
FBS - Front Bumper Stabilizer (optional)
Outrigger monitoring system (for verification only)
Outrigger motion alarm

Full extension

- ◆ Center to center: 24' 3" (7,3 m)

Full retraction

- ◆ Center to center: 17' 6" (5,3 m)

Operator aids



45142S is externally routed A2B cable LMI with crane function cut-offs for overload protection. Color graphic display and HDRI-Hoist Drum Rotation Indicator. Crane is shipped remote ready.

Hoist, Rope and Hook



Maximum theoretical line speed: 300 fpm (91 mpm)

Hoist, Rope and Hook Cont.



Maximum theoretical bottom-layer line pull:
11,500 lb (5,216 kg)



Main winch cable diameter: 9/16" (14,3 mm).
6 x 25 EIPS IWRC Wire Rope



Line length: 500 ft. (152,4 m)



Main winch: Bent axis 2-speed hydraulic motor (activated electrically)
Third Wrap Limiter on both Main and Auxiliary Winch.

Overhaul ball: 7T (6,4 mt) capacity hook with heavy-duty swivel and weight is provided for single line operation.

Hydraulics



8-bolt direct mounted PTO and SAE C output (factory mounted units only)
1-Section Variable Displacement Piston Pump, SAE C input.
Piggy back Fixed Gear Pump
Hydraulic Reservoir Capacity: 155 Gallon
Pump Sections @ 2000 RPM with 100 PSI

- ◆ Variable Displacement Pump: 77 GPM (291 lpm)
- ◆ Fixed Displacement Gear Pump: 12 GPM (45 lpm)

Tiltable Cab/Cab Controls



Standard features:



Curved glass, 0° to 20° cab tilt, Sliding door, heated cloth seat, 8 seat adjustments, lumbar support, reclining and adjustable head rest, sliding windows, rear pop out window, top hinged hatch, with guard, front and top windshield wiper, heater, air conditioning, 12 volt DC outlet, USB ports, engine monitoring system, E-coated cab (10 year rust warranty)







Controls:

PLC crane controller, CANBUS communication, J1939 truck engine communication, electric hand and foot throttle, twin dual axis joysticks, electric/hydraulic valve actuation, electronic sensor monitoring, Hirschmann/PAT or 3B6 LMI system available, wired ATB and wired wind speed sensors, telematics, GPS monitoring, remote diagnostic capability, Work Area Definition (WADs)

OPTIONS

Boom	
Maximum Tip Height	
	<p>45142S</p> <ul style="list-style-type: none"> Maximum tip height: 151' (46 m)
Jibs	
	<p>45142S</p> <ul style="list-style-type: none"> 2-Section telescoping jib 31' (9,4 m) to 55' (16,8 m)
Maximum Tip Height with Extension	
	<p>45142S</p> <ul style="list-style-type: none"> Maximum tip height with extension: 204' (62,1 m) Maximum tip height with extension retracted: 181' (55,2 m)
Tool Boxes	
	<p>Tool Boxes</p> <ul style="list-style-type: none"> 24 in. L x 18 in. W x 18 in. H (610 mm L x 457 mm W x 457 mm H) 48 in. L x 24 in. W x 24 in. H (1,219 mm L x 610 mm W x 610 mm H)
Auxiliary Winch	
	<p>Auxiliary Winch: Bent axis 2-speed hydraulic motor (activated electrically) Third Wrap Limiter on winch</p>

Hydraulics	
	<p>Optional Front Bumper Stabilizer Optional Hydraulic Tank Heater</p>
Cab	
	<p>Video camera (1 or 2) Cab weather band radio system</p>
2-person Basket	
	<p>Consult Manitex for specific application and rating</p> <ul style="list-style-type: none"> 2-person Steel Gravity Leveled Basket with Friction Brake 2-person Aluminum or Steel Quick-Attached Rotating Basket
Operator aids	
	<p>4-function radio remote crane control system with joy sticks</p> <ul style="list-style-type: none"> 900 Mhz 400 Mhz <p>A922 Aerial Lift Manbasket Dual Rating Wired Wind Speed Sensor</p>
Hoist and Hook	
	<p>Auxiliary lower sheave block for 2-8 part lines Load blocks 1-3, 1-6, 2-6 part lines</p>

NOTES

Manitex



TC450

45-Ton (40, 8 mt) TELESCOPIC CRANE
TC450 SERIES PRODUCT GUIDE

UPTIME

UPTIME is the Manitex commitment to complete support of thousands of units working every day.

MANITEX

3000 South Austin Avenue
Georgetown, Texas 78626

1-877-314-3390 | www.Manitex.com

MTX-TC450-PC-EN-V1-0915