

GROVE[®]

**FULL HYDRAULIC
SELF-PROPELLED CRANE**

**MODEL
RT49**
10-Ton Capacity

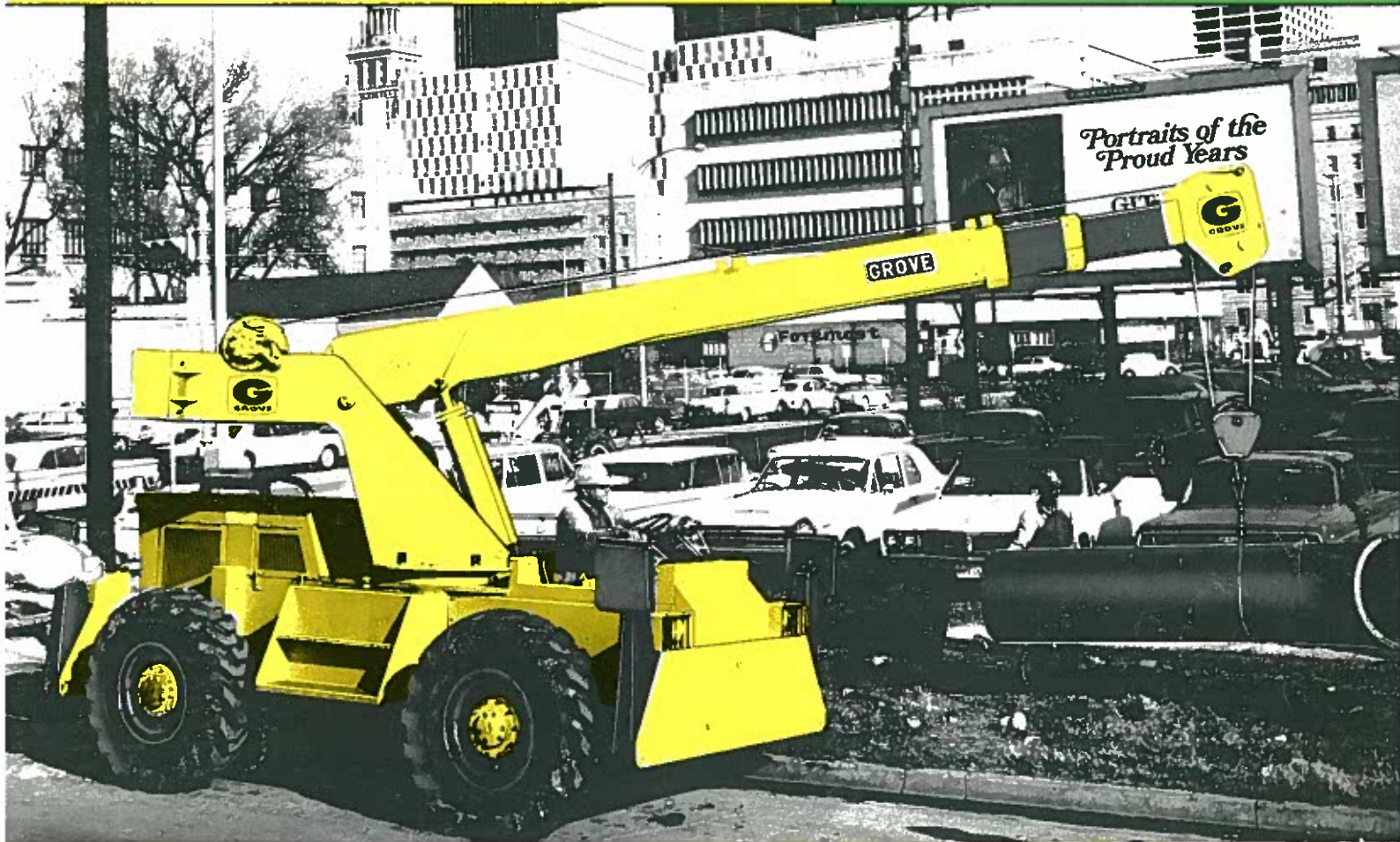

FEATURES

- 20,000 lbs. Capacity at 10'
- 21-51 ft. Power Telescoping Boom
- Power Shift Transmission—6 speeds forward & reverse
- Hi-Lo range selection automatically shifts 4-wheel—2-wheel drive
- 4-Wheel Hydraulic Power Assist Steering & Brakes
- 75° Maximum elevation
- 360° Continuous rotation — Ball-bearing Swing Circle — Grove Planetary Swing
- Automatic Hydraulic Rear Axle Oscillation Lockouts
- Hydraulic Pump Disconnect



SPECIFICATIONS

BOOM - 21 ft. - 51 ft., (6.4-15.54m), 3 section, full power telescoping boom.

*18 ft. - 42 ft., (5.49-12.8m), 3 section, full power telescoping boom. Boom telescope sections are individually controlled and supported on graphite impregnated nylatron wear pads. Pendulum boom angle indicators on both sides of boom. Integral holding valves on each telescoping cylinder. Side adjustable wear pads eliminate metal to metal contact of inner sections.

BOOM NOSE - Two sheaves mounted on heavy duty needle bearings. Removable pin type rope guards allow easy reeving. Rope dead end on one side of the boom nose.

BOOM ELEVATION - Dual double-acting hydraulic cylinders with holding valve. Elevation from 0° to 75°.

***JIBS** - 14 ft. (4.27m) "Stowaway" for 18 - 42 ft. (5.49-12.8m) boom. 17 ft. (5.18m) "Stowaway" for 21 - 51 ft. (6.4-15.54m) boom. All jibs have self-equalizing suspension and jib backstops.

SWING - Ball bearing swing circle, 360° continuous rotation. "Grove Planetary Swing" with automatic disc swing brake. Swing speed 2.5 RPM.

***ENCLOSED CAB** - Frame mounted, all steel, full vision with fixed tinted skylight, laminated safety glass windows. Electric windshield wiper, electric fan-type defroster, hot water heater, dome light, left and right hand doors with locks. Right and left side sliding vent windows and window locks.

***OPEN CAB** - Frame mounted, all steel full vision with fixed tinted skylight, laminated safety glass windows, electric windshield wiper, and dome light.

CAB INSTRUMENTATION - Engine oil pressure gage, engine water temperature gage, electric fuel gage, transmission and torque converter oil temperature gage, voltmeter, engine hourmeter.

OUTRIGGERS - Hydraulic, front and rear, cantilever type, with integral check valves. Sequence control arrangement eliminates accidental actuation.

MAIN FRAME - 18 in. (457mm) rectangular box section, all welded and reinforced construction. Outriggers are integral with main frame.

TRANSMISSION AND TORQUE CONVERTER - Engine mounted converter 2.54:1 stall ratio with PTO for hydraulic pumps. Remote mounted full powershift transmission with rear axle disconnect.

SPEEDS - 6 Forward and 6 Reverse.

AXLES - Front: Planetary drive with dual steering cylinders mounted rigid to frame.

Rear: Planetary drive with dual steering cylinders mounted to allow 0 in. to 12 in. (0-305mm) oscillation. (No-spin optional)

OSCILLATION LOCKOUTS - Automatic hydraulic on rear axle. Allows oscillation only with boom over front.

SERVICE BRAKES - Power assist hydraulic on all wheels. Size 17-1/4 in. x 4 in. (438mm x 102mm). Total lining area: 552 sq. in. (3,562cm²)

PARKING BRAKES - Mechanical on driveline. Hand lever control. Size 13-3/8 in. x 2 in. (340mm x 51mm). Total lining area: 53.5 sq. in. (345cm²).

STEERING - Front: Power assist hydraulic control. Rear: Full hydraulic; tiller bar control. Independent front and rear steer control allows maximum maneuverability.

TIRES - 14:00x24 - 10 ply, tubeless power grader lug (nylon).

*15.5x25 - 12 ply, power traction.

*17.5x25 - 14 ply, power grader.

HYDRAULIC SYSTEM:

RESERVOIR - 62 gallon (235 liter) capacity all steel welded construction with integral baffles, and dip stick.

FILTER - Return line type, full flow with by-pass protection, replaceable cartridges. 10 micron rating.

PUMPS - Two main gear pumps, 73 GPM (276lpm) capacity. Pump disconnect lever operated from carrier deck. Separate pump for front steer - 18.7 GPM (71lpm).

CONTROL VALVES - Precision four-way double-acting with integral load check, main and circuit relief valves. Two individual valve banks permitting simultaneous independent control of two crane functions. Maximum operating pressure 2500 PSI (175.8 kg/cm²).

POWER DISTRIBUTION - (Swing, boom telescope, rear steer) (Boom elevation, hoist, outriggers) (Front steer).

MISCELLANEOUS STANDARD EQUIPMENT - Cab guard, 2-3/4 lb. (1.25kg) dry type fire extinguisher, electric horn, protecto seal fuel cap, full engine hood.

HOIST SPECIFICATIONS:

DESCRIPTION: Power up and down, equal speed, planetary reduction with integral automatic brake.

HOIST DATA	MAIN HOIST Grove Model 15 S-11A
Drum Dimensions	12 in. diameter (305mm) 11 in. length (279mm) 17.5 in. flange dia. (445mm)
Performance Single line speed Single line pull	200FPM (61 m/min) 9,165 lb. (4,157kgs)
Drum Rope Storage Capacity	**490 ft. of 1/2 dia. Rope (149.35mm of 13mm)
Permissible Single Line Rope Pull	1/2 in. (13mm) 6x37 Class 7200 lb. (3266kgs) 1/2 in. (13mm) 19x7 Class 6150 lb. (2790kgs)

** 6th Layer of rope not recommended for hoisting operations.

ENGINE SPECIFICATIONS

MAKE & MODEL TYPE BORE & STROKE DISPLACEMENT HORSEPOWER (NET) GOVERNED RPM TORQUE (NET) ELECTRICAL SYSTEM COMBUSTION SYSTEM COOLING SYSTEM FUEL CAPACITY ALTERNATOR BATTERY AIR CLEANER HOURMETER	Ford 300 6 Cylinder O.H.V. Gasoline 4.00 in. x 3.98 in. (102mm x 101mm) 300 cu. in. (4916cm ³) 123 @ 2800 RPM 2800 253 lbs. ft. @ 1800 RPM 12 Volt, Neg. Ground 4 Cycle Naturally Aspirated Liquid 49 Gallons (185 liters) 38 Amp, 12 Volt (1) 62 A. H., 12 Volt Oil Bath Yes	*GM4-53N 4 Cylinder O.H.V. Diesel 3.875 in. x 4.50 in. (98mm x 114mm) 212 cu. in. (3474cm ³) 112 @ 2800 RPM 2800 257 lbs. ft. @ 1800 RPM 12 Volt, Neg. Ground 2 Cycle with blower Liquid 49 Gallons (185 liters) 55 Amp, 12 Volt (1) 204 A. H., 12 Volt Dry Type Yes	*Cummins V-378 6 Cylinder O.H.V. Diesel 4.625 in. x 3.75 in. (117mm x 95mm) 387 cu. in. (6194cm ³) 125 @ 2800 RPM 2800 260 lbs. ft. @ 1925 RPM 12 Volt, Neg. Ground 4 Cycle Naturally Aspirated Liquid 49 Gallons (185 liters) 58 Amp, 12 Volt (2) 204 A. H., 12 Volt Dry Type Yes
---	--	---	---

SPECIFICATIONS



SPEED AND GRADABILITY

FORWARD DRIVE	TRANSMISSION RANGE	GEAR SHIFT	MAXIMUM SPEED		GRADEABILITY @ STALL (%)	TRACTIVE EFFORT	
			(MPH)	(km/h)		LBS. AT STALL	KGS.
4 Wheel Drive	Low	1st	2.7	4.3	91	33,452	15,175
4 Wheel Drive	Low	2nd	5.1	8.2	47	17,673	8,016
4 Wheel Drive	Low	3rd	15.1	24.3	15	5,996	2,720
2 Wheel Drive	High	1st	6.4	10.3	37	14,138	6,413
2 Wheel Drive	High	2nd	12.2	19.6	19	7,448	3,378
2 Wheel Drive	High	3rd	35.7	57.4	5	2,540	1,152

Note: Performance based on 36,000 lbs. (16330kg) GVW and standard SAE engine rating conditions using standard engine, tires, transmissions and axles. Performance data may vary plus or minus 10% due to variations in engine performance and vehicle weights.

WORKING WEIGHTS

STANDARD MACHINE WITH	TOTAL WEIGHT		AXLE WEIGHT DISTRIBUTION			
	Lbs.	Kgs.	FRONT		REAR	
	Lbs.	Kgs.	Lbs.	Kgs.	Lbs.	Kgs.
21 to 51 Ft. (6.4 - 15.54m) Boom	33,060	14,996	19,340	8,773	13,720	6,223
18 to 42 Ft. (5.49 - 12.8m) Boom	32,560	14,769	17,960	8,147	14,600	6,622

NOTE: Weights may vary plus or minus 3% due to manufacturing tolerances. Jib and Hook Block included in weights.

DIMENSIONS

TAIL SWING — 8 ft. ½ in. (2.45m)

TURNING RADIUS — 14 ft. 7½ in. (4.46m)

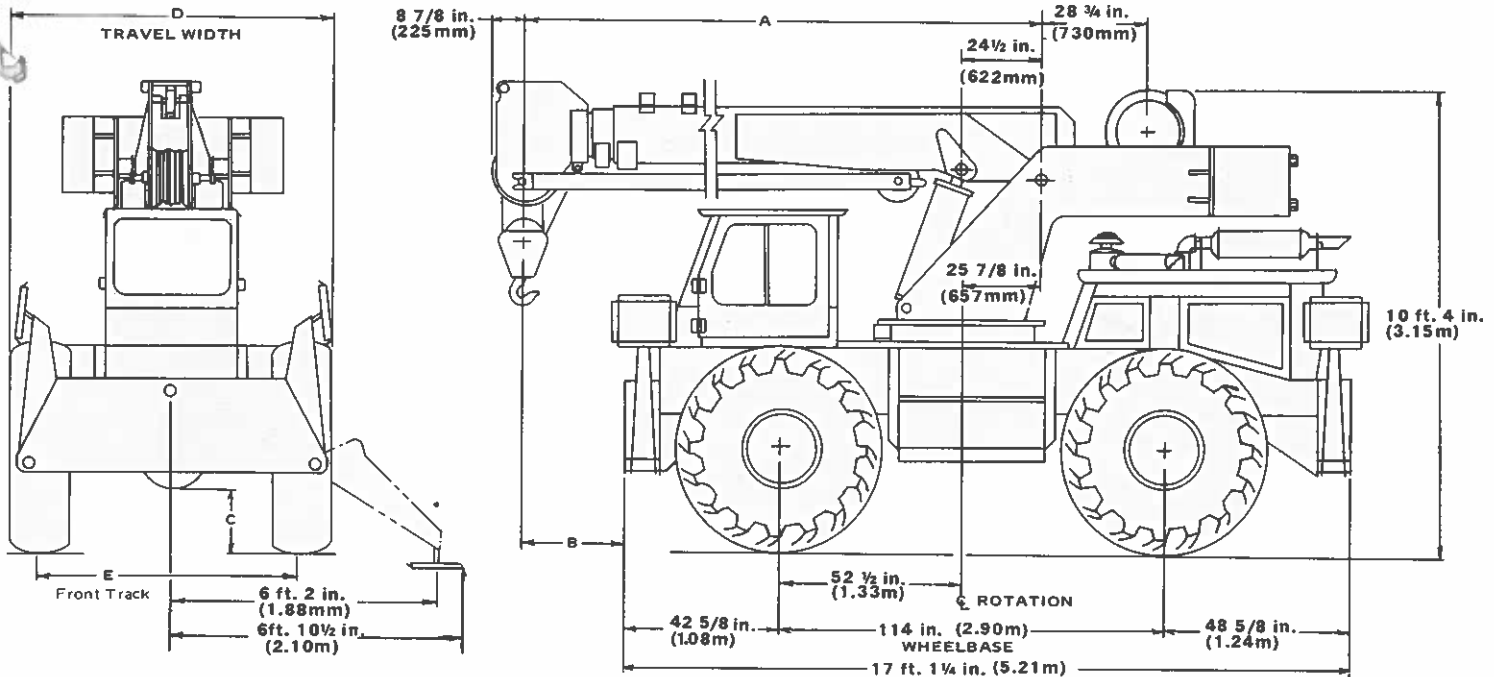

BOOM	A	B
18 ft. - 42 ft. (5.49 - 12.8m)	17 ft. 7 in. (5.36m)	7 ft. 6 in. (2.29m)
21 ft. - 51 ft. (6.4 - 15.54m)	20 ft. - 7 in. (6.27m)	10 ft. - 6 in. (3.20m)

TIRE SIZE	C	D	E
14.00x24	14 ½ in. (368mm)	95 7/8 in. (2.44m)	79 ½ in. (2.02m)
15.50x25	13 in. (330mm)	95 ½ in. (2.43m)	79 ½ in. (2.02m)
17.5x25	14 in. (356mm)	95 7/8 in. (2.44m)	77 ½ in. (1.97m)

* DENOTES OPTIONAL EQUIPMENT

Constant improvement and engineering progress make it necessary that we reserve the right to make specification, equipment, and price changes without notice.

MORE PROFITABLE MORE VERSATILE

for a wider variety of lifting & handling jobs!

THE PREFERENCE FOR GROVE CRANES among profit-minded users reflects the user's need for the versatility and advanced design engineering offered in all Grove Hydraulic Cranes. They add up to profit-making performance . . . a measurable value that tells him he is getting his money's worth on his Grove Crane investment. That's why the smart crane buyers have made Grove their **NUMBER ONE CHOICE**.

A FULL LINE OF HYDRAULIC CRANES . . . in addition to a full line of rough terrain cranes, Grove also offers a complete line of carrier-mounted cranes including an 80-ton model with a boom tip height of 208'. Ask your Grove Distributor for details.



HYDRAULIC CRANES

GROVE MANUFACTURING COMPANY

Division of Walter Kidde & Company, Inc.
KIDDE

Box 21
Shady Grove, Pennsylvania 17256

RIGID FRAME . . . EXCELLENT STABILITY!

An 18" deep all-welded and reinforced rectangular box section frame, including outrigger housings as an integral structural part, provides the rigidity needed to resist the torsional stresses encountered in rough-terrain operation. This assures the proper alignment of components, resulting in longer service life . . . more on-the-job availability. Outriggers are set or retracted by a special safety control arrangement which makes it impossible to accidentally retract the outriggers once set.



COMFORTABLE CABS DESIGNED FOR OPERATOR CONVENIENCE!

Grove cabs are built to provide maximum visibility and comfort for the operator. Controls are arranged for operator convenience, especially during simultaneous operations. The optional fully enclosed cab features skylight, safety glass windows, electrical windshield wiper and heater.



BALL-BEARING SWING CIRCLE!

A large 40" "sealed-for-life" 360° continuous rotation ball-bearing swing circle. Grove planetary drive and automatic disc swing brake provide a minimum of maintenance and smooth continuous swing.

