

**PETTIBONE®**

**» CARY-LIFT 154**







# WE JUST RAISED THE BAR

How do you make a great product even better? You start from scratch. You set the old design aside and start over, engineering a new product around the needs of the end user.

That's exactly what we did when we redesigned the new Cary-Lift 154. The result is one tough machine that's more productive, easier to service and more cost effective than ever before.

**PETTIBONE®**



# SHARPER TURNING RADIUS

Forward. Reverse. Forward. Reverse. Imagine how much time is wasted making multiple-point turns. That's why we gave the straight rigid frame of the new Cary-Lift 154 a shorter wheelbase and better turning radius. No other machine in its class can turn as sharply without sacrificing load capacity or stability.

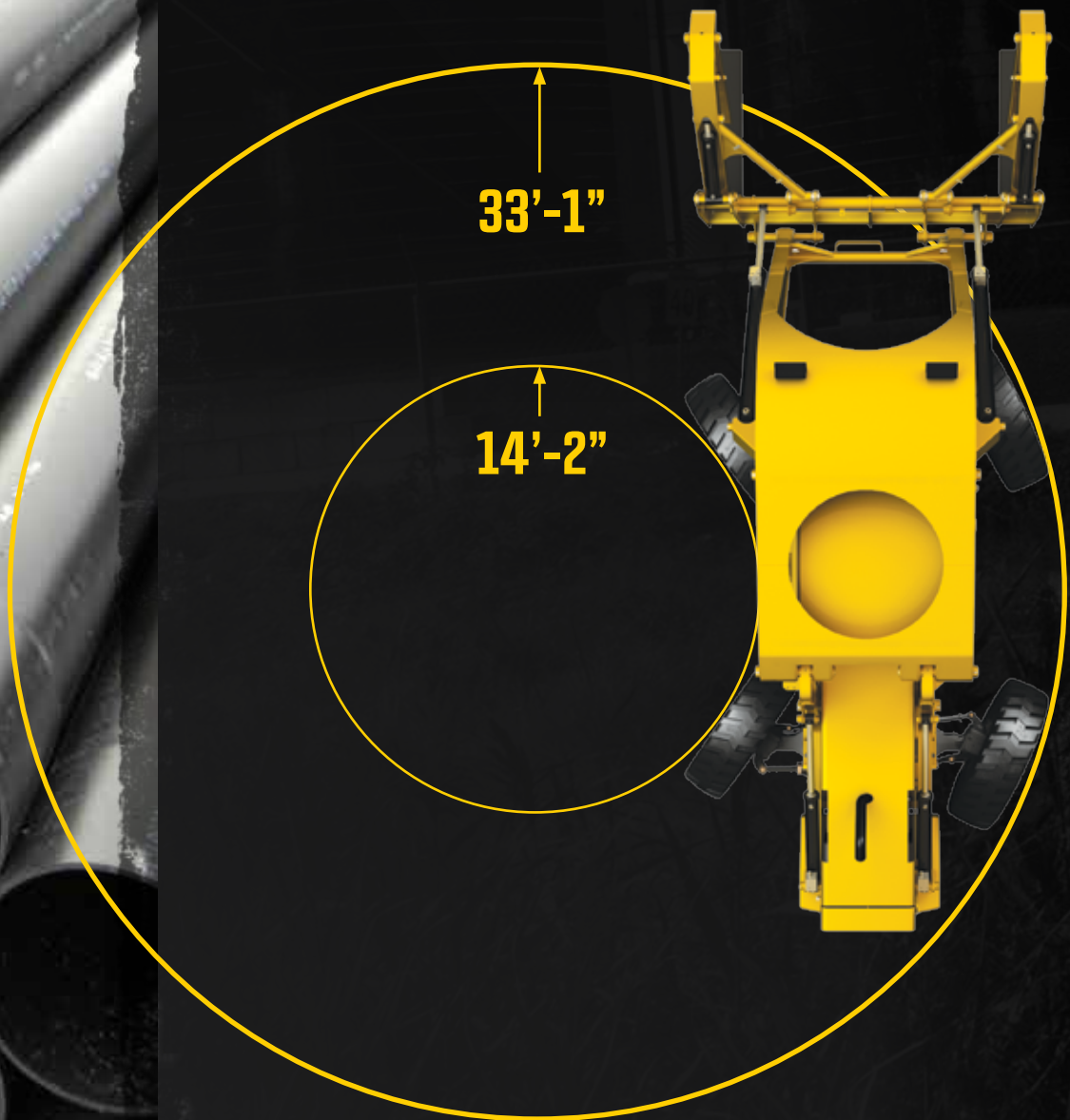



## REDUCED COST

Not only did we make the new Cary-Lift 154 better — we also made it more cost effective. To do this, we analyzed every feature of the machine and came up with new ideas to streamline the design. But we didn't sacrifice quality in the process. It's still everything you'd expect in a Pettibone.



## LOWER MAINTENANCE

The Cary-Lift features balanced dual fuel tanks with a single ground-level refueling port. That means you spend more time in-between refueling, and less time filling it up. Plus, greasing the machine is now easier, thanks to a centralized lubrication system, which provides one access point for most lubrication needs.



# PUTTING THE “WORK” IN WORKHORSE

- > 15,000-pound load capacity
- > 4-wheel drive with 3 steering modes
- > 6.7-liter, 160-horsepower Cummins engine
- > New IQAN controlled electrohydraulic system
- > Wider lift arms and front balers for enhanced load stability
- > Quick-attach system in development for increased versatility and productivity



## MORE COMFORT

A **sliding door** and **swivel seat** offer easy access to the cab. Once you're inside, the improved door seals provide a cleaner, quieter environment, and a higher-output air conditioning and heating system allows better climate control.



High-output **LED lighting** provides clear, bright light.

Lift arm design allows **full front visibility**.

Sloped engine compartment **improves rear line of sight**.

## **EASY & SAFE** OPERATION

Using the improved **IQAN control system**, the operator can steer the machine with his left hand and hold the multi-function joystick with his right hand. The new joystick offers intuitive fingertip controls to efficiently shift gears and control the hydraulics. This means you can work non-stop without ever taking your hands off the wheel or changing hand positions. It also means the Cary-Lift 154 is safer and more productive than ever before.

# SPECIFICATIONS

DIMENSIONS	
Height	11' (335 cm) - carrying position 18' 9" (572 cm) - max raised position
Fork Length	60" (152 cm) standard, others available
Ground Clearance	19" (48 cm)
Wheel Base	10' (305 cm)
Overall Length	25' (762 cm) - carrying position 30' 3" (922 cm) - at max reach
Overall Width	10' 5" (320 cm)
Total Operating Weight	42,200 lbs (19,142 kg)
ENGINE	
Model/Power	160 HP (119 kW) Cummins QSB 6.7L Tier III
Fuel Tank	79 gal. (299 L)
Fan	Hydraulically driven and reversible
Cooling Package	CAC, radiator, transmission and hydraulic oil
Heating	Engine block heater
HYDRAULIC SYSTEM	
Control System	IQAN: Infinite variable control, individual operator settings, onboard diagnostics
Filter	Hydraulic return oil filtration (10 micron)
Tank	40 gal. (151 L)
Sway Cylinder	8° both right and left of center
Joystick	Single joystick operation with push button shifting

# WARRANTY

	1 Year	Full machine and attachment
	2 Years	Powertrain and major hydraulic components
	3 Years	Machine structure

PERFORMANCE	
Max Load Capacity (Retracted)	15,000 lbs (6,804 kg) 24" LC from back of fork 30,000 lbs (13,608 kg) tipping load
Max Load Capacity (Extended)	10,000 lbs (4,536 kg) 24" LC from back of fork 13,300 lbs (6,033 kg) tipping load
Maximum Lift Height	14' (427 cm)
Below Grade Reach	1.1" (2.79 cm)
Maximum Reach from Tires	2' 2" (66 cm) retracted 6' 11" (211 cm) extended, forks parallel 8' 10" from ground 5' 9" (175 cm) extended, forks parallel at carrying height
Maximum Travel Speed	4.4 mph (7.1 km/h) 1st gear 8.6 mph (13.8 km/h) 2nd gear 24.4 mph (39.27 km/h) 3rd gear
Turning Radius	16' 7" (505 cm)
Transmission	3 speed Powershift
Axles	AxleTech high steer
Steering	Hydraulic power steering w/2 wheel, 4 wheel and crab steering
Service Brakes	4-wheel outboard dry hydraulic disc
Parking Brake	Spring applied hydraulic release
Tires	16.00x25-28 ply interchangeable
Lighting	Full LED lighting

# FEATURES & OPTIONS

OPERATOR CAB	
Large tinted safety glass windows Adjustable suspension seat w/seat belt, padded armrests & lumbar support	Tilt/telescopic steering column All-weather cab Dome light
AVAILABLE ATTACHMENTS	
Fork frames Pipe and pole balers	Log balers Scrap balers
OPTIONS & ACCESSORIES	
Back up camera Attachment camera	Autoshift Air-conditioned cab

\* Specifications are subject to change.

## PETTIBONE®

**PETTIBONE, LLC**  
1100 Superior Avenue  
Baraga, MI 49908

P: 800.467.3884  
info@gopettibone.com  
www.gopettibone.com