

NATIONAL CRANE by 

Series 1300A

**Hydraulic
Crane
15 Ton**

**Load
Ratings**

 **DANGER**

**AN UNTRAINED OPERATOR
SUBJECTS HIMSELF AND
OTHERS TO**

DEATH OR SERIOUS INJURY

**YOU MUST NOT OPERATE
THIS CRANE UNLESS**

- You have been trained in the safe operation of this crane.
- You read, understand and follow the safety and operating recommendations contained in the crane manufacturer's manuals, your employers work rules and applicable government regulations.
- You are sure that all safety signs, guards and other safety features are in place and in proper condition.

DANGER

GENERAL

1. This equipment can be hazardous if improperly maintained or operated. Read and comply with the Operator's Manual supplied with this machine for information on safety, operation and maintenance before operating this machine. If these manuals are missing, order replacements from National Crane through the distributor.
2. Rated loads shown on the capacity chart pertain to this machine as originally manufactured and equipped. Modifications to the machine or use of equipment that is not factory specified or approved can be hazardous. Refer to capacity deduction chart for weights which must be deducted from rated loads when accessories are attached to boom or loadline.

SET-UP

1. Inspect vehicle and crane including crane operation prior to use each day.
2. Load ratings shown on the appropriate charts are maximum allowable loads with the crane mounted on a factory approved truck and all outriggers at either full span, at mid span range, or retracted and set on a firm level surface so the crane is level and the tires are suspended. This machine is not rated for use without outriggers. All outriggers must extended equally - Mid span must be pinned.
3. Depending on the nature of the supporting surface, structural supports under the outrigger floats may be necessary to spread the load to a larger bearing surface.
4. Always level the crane with the level indicator, located at each outrigger control station.

OPERATION

1. Operation of this equipment in excess of maximum load rating and disregard of instructions is hazardous. Always refer to the capacity chart for load and area limits before operating the crane. Rated loads at rated radius shall not be exceeded. Overloading this crane may cause structural collapse or instability.
2. Use the LMI / angle indicator as a reference only. When lifting maximum loads, measure radius and be certain of load weight.
3. Full extended outrigger rated loads do not exceed 85% of the tipping load as determined by SAE Crane Stability Test Code J765a when mounted on a factory recommended truck. Mid span and retracted outrigger stability loads are determined per SAE J1289 APR81. Structurally limited ratings on the capacity chart are shaded. Stability limited loads are not shaded. Machine will not always tip before structural damage occurs.

4. Rated loads include the weight of the hook block, slings, and other lifting devices. Their weights must be subtracted from the listed rated load to determine the net load that can be lifted.
5. Rated loads must be reduced when lifting at the boom tip with a jib stowed. Refer to the chart labeled "Rated Load Reductions With Jib (lb)" for the reduction at each boom length.

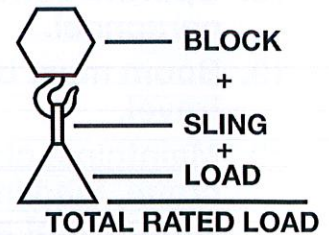

6. Rated loads are based on freely suspended loads. Always position the boom tip directly over the load before lifting. No attempts shall be made to push down with the boom or move the load sideways in any direction by pulling or dragging the load.
7. The user shall operate at reduced ratings to allow for adverse job conditions such as soft or uneven ground, high winds or erratic operation which produce swinging (side) loads, experience of personnel, two machine lifts, or other hazardous conditions for safe operation.
8. Rated loads account for wind to 20 mph on the boom capacities and to 15 mph on jib capacities. Above these wind velocities, loads, and/or boom lengths must be appropriately reduced for safe operation.
9. Do not operate at any radii beyond stability limit line on range chart. At these positions, the machine can overturn without any load on the hook.
10. When the boom length or radius or both are between points listed on capacity chart, the smallest load shown at either the next larger radius or boom length shall be used.
11. Do not exceed jib capacities at any reduced boom length.
12. It is safe to telescope or retract any load listed if rating is not exceeded. Boom must be fully retracted against boom stops at all times when lifting minimum boom length capacity loads.
13. Always pay out loadline before extending boom to avoid damaging loadline or crane structure.
14. Loads lifted must be within safe winch capacity as well as safe crane capacity. Multiple part rope reeving must be used on loads exceeding winch single part rated pull. Jibs are rated for single part use only.
15. Do not operate the boom over personnel or allow them to walk or stand beneath the boom or load.
16. Do not allow personnel on carrier deck, or crane frame area when rotating crane.
17. Do not handle personnel on loadline unless the requirements of the applicable national, state, and local regulations and safety codes are met. Do not permit anyone to ride loads, hooks, slings or other rigging for any reason. Handling of personnel is only permitted with full extension of all outrigger beams. Use only National Crane approved baskets.

18. Operate controls slowly and smoothly to avoid damage to crane or personnel.
19. Boom must be in carrying rack and outriggers fully retracted for travel.
20. Maintain a clearance of at least 10 feet between any part of the crane, loadline or load and any electrical line carrying up to 50,000 volts. 1 foot additional clearance is required for every additional 30,000 volts or less.

DEFINITIONS

1. **Load radius**—Horizontal distance from the centerline of rotation before loading to the center of the vertical loadline or block with load applied.
2. **Loaded boom angle**—Loaded boom angle is the angle between the first section boom and the horizontal, after lifting the rated load at the rated radius. The boom angle before loading should be greater to account for deflections. The loaded boom angle combined with the boom length give only an approximation of the operating radius.
3. **Working area**—Area measured in a circular arc above the center line of rotation as shown on the Working Area Diagram.
4. **Freely suspended load**—Load hanging free with no direct external force applied except by the loadline.
5. **Side load**—Horizontal side force applied to the lifted load either on the ground or in the air.
6. **No load stability limit**—The stability limit radius shown on the range diagrams is the radius beyond which it is not permitted to position the boom plus block configuration because machine can overturn without any load on the hook.
7. **Structural length limit**—An area where the boom or the boom with jib deployed cannot be extended because of structural limitations.
8. **PCSA**—Power Crane and Shovel Association.

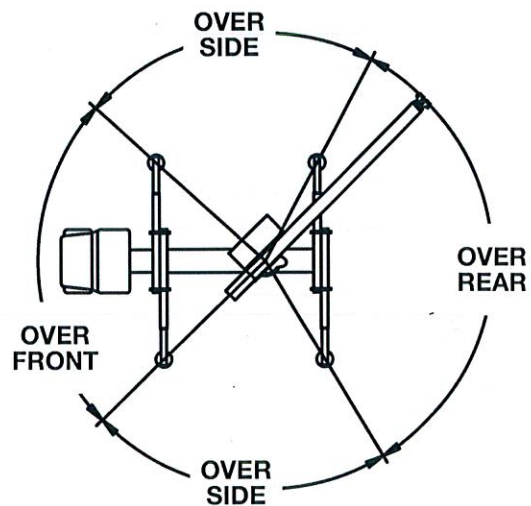

WORK AREA DIAGRAM

INFORMATIONAL DATA

OUTRIGGERS



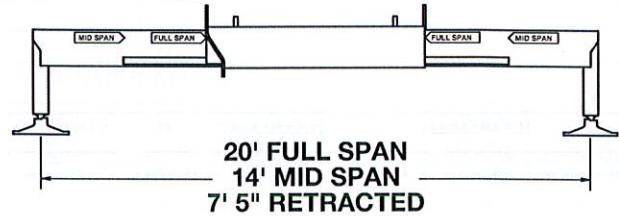

1. Outrigger spread from center to center of the outrigger floats retracted is 7' 5", at mid span is 14' and at full span is 20'.
2. No outrigger pad load exceeds 55,000 lb maximum at full span, 61,500 lb maximum at mid span, or 54,000 lb maximum at retracted.



WEIGHT REDUCTIONS FOR LOAD HANDLING DEVICES (See load chart for jib deductions)

Hookblocks are rated at maximum capacity for the block. Do not exceed rated cable pull with any block.

5 t	Downhaul weight	150 lb
12 t	1 sheave block	305 lb
19 t	2 sheave block	350 lb

NOTICE			1 Part Line	2 Part Line	3 Part Line	4 Part Line
<ul style="list-style-type: none"> Do not deadhead line block against boom tip when extending boom. Keep at least 3 wraps of loadline on drum at all times. Use only 9/16" diameter rotation resistant cable with 38,500 lb breaking strength on this machine. Maximum capacity with "burst of speed" is 3,000 lb. 						
Maximum Boom Length at Maximum Elevation with Rigging Shown with Load Block at Ground Level			154 ft Boom & Jib	110 ft	78 ft	62 ft
Winch	Cable Supplied	Average Breaking Strength	Lift and Speed	Lift and Speed	Lift and Speed	Lift and Speed
Standard Planetary Winch	9/16" diameter rotation resistant	38,500 lb	7,700 lb 164 fpm	15,400 lb 82 fpm	23,100 lb 55 fpm	30,000 lb 41 fpm
"Burst of Speed"	9/16" diameter rotation resistant	38,500 lb	3,000 lb 265 fpm	6,000 lb 132 fpm	9,000 lb 88 fpm	12,000 lb 66 fpm

All winch pulls and speeds are shown on the fourth layer. Winch line pulls would increase on the first, second and third layers. Winch line speed would decrease on the first, second and third layers. Winch line pulls may be limited by the winch capacity or the ANSI 5 to 1 cable safety factor. These are shown below:

Winch	4th Layer Drum Pull	Allowable Cable Pull
Standard planetary	7,700 lb (low speed) (3,000 lb "burst of speed")	7,700 lb

13110A
110 ft BOOM
25 – 44 ft JIB

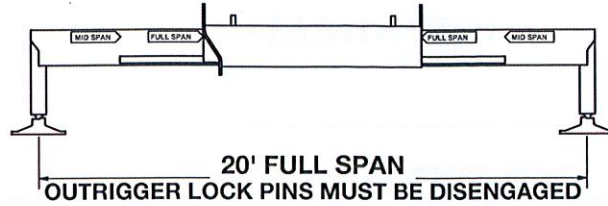

FULL SPAN
OUTRIGGER

32 ft – 110 ft BOOM RATED LOADS WITHOUT JIB

LOADED RADIUS (ft)	LOADED BOOM ANGLE (deg)	32 ft BOOM (ft)	LOADED BOOM ANGLE (deg)	A 46 ft BOOM (ft)	LOADED BOOM ANGLE (deg)	B 62 ft BOOM (ft)	LOADED BOOM ANGLE (deg)	C 78 ft BOOM (ft)	LOADED BOOM ANGLE (deg)	D 94 ft BOOM (ft)	LOADED BOOM ANGLE (deg)	110 ft BOOM (ft)
5	78.5	30,000										
8	74.5	30,000										
10	70.5	30,000	77.5	29,100								
12	66.5	30,000	75	28,900								
15	60	25,500	71	24,000	77	23,000						
20	48.5	19,450	63.5	18,450	72	17,550	77	17,000				
25	34	14,900	56	14,800	67	14,100	73	13,600	77.5	13,300		
30			48	12,150	61.5	11,650	69	11,200	74	10,950	77	7,950
35			38.5	9,600	56	9,850	64.5	9,450	70.5	9,200	74	6,300
40			27	7,600	49.5	7,950	60.5	8,100	67	7,850	71.5	5,950
45					43.5	6,350	56	6,600	64	6,800	69	5,700
50					36	5,100	51.5	5,350	60	5,550	66	5,400
55					26	4,050	46	4,300	56	4,550	63	4,750
60					8.5	2,650	40	3,500	52	3,700	59.5	3,900
65							33.5	2,850	48	3,000	56	3,200
70							25.5	2,250	43	2,450	52.5	2,600
75							13	1,750	38	1,950	49	2,100
80									32	1,500	45	1,650
85									25	1,100	41	1,250
90									15	750	36	900
95											31	600
100												
	0	6,300	0	3,250	0	1,450	0					

25 – 44 ft JIB RATED LOADS

LOADED RADIUS (ft)	LOADED BOOM ANGLE (deg)	25 ft JIB (ft)	LOADED BOOM ANGLE (deg)	44 ft JIB (ft)
35	76.5	4,200		
40	75	4,100	76.5	2,500
45	73	4,000	75.5	2,500
50	71	3,850	74	2,500
55	69	3,600	72.5	2,500
60	66.5	3,300	70.5	2,350
65	64	3,050	68.5	2,250
70	61.5	2,500	66.5	2,150
75	59	2,000	64.5	2,050
80	56	1,550	62	1,900
85	53.5	1,100	60	1,800
90	50.5	700	57	1,400
95			54.5	1,050
100			51.5	650
105				

RATED LOAD REDUCTIONS WITH JIB

BOOM LENGTH (ft)	25 – 44 ft JIB STOWED
32	Reduce load 800 lb
46	Reduce load 600 lb
62	Reduce load 450 lb
78	Reduce load 350 lb
94	Reduce load 300 lb
110	Reduce load 250 lb

Note:

1. All capacities are in pounds, angles in degrees, and radii in feet.
2. Loaded boom angles are given as reference only.
3. Shaded areas are structurally limited capacities.
4. Handling of personnel is only permitted with full span extension of all outrigger beams.

13110A

FULL SPAN OUTRIGGER 20 ft

110 ft BOOM

25 – 44 ft JIB

LMI OPERATING CODE	
OPERATING MODE	
01	Main Boom – No Jib Stowed
02	Main Boom – Jib Stowed
03	25 ft Tele Jib
04	44 ft Tele Jib
11	Man Basket On Main Boom
12	Man Basket on 25 ft Tele Jib
13	Man Basket on 44 ft Tele Jib

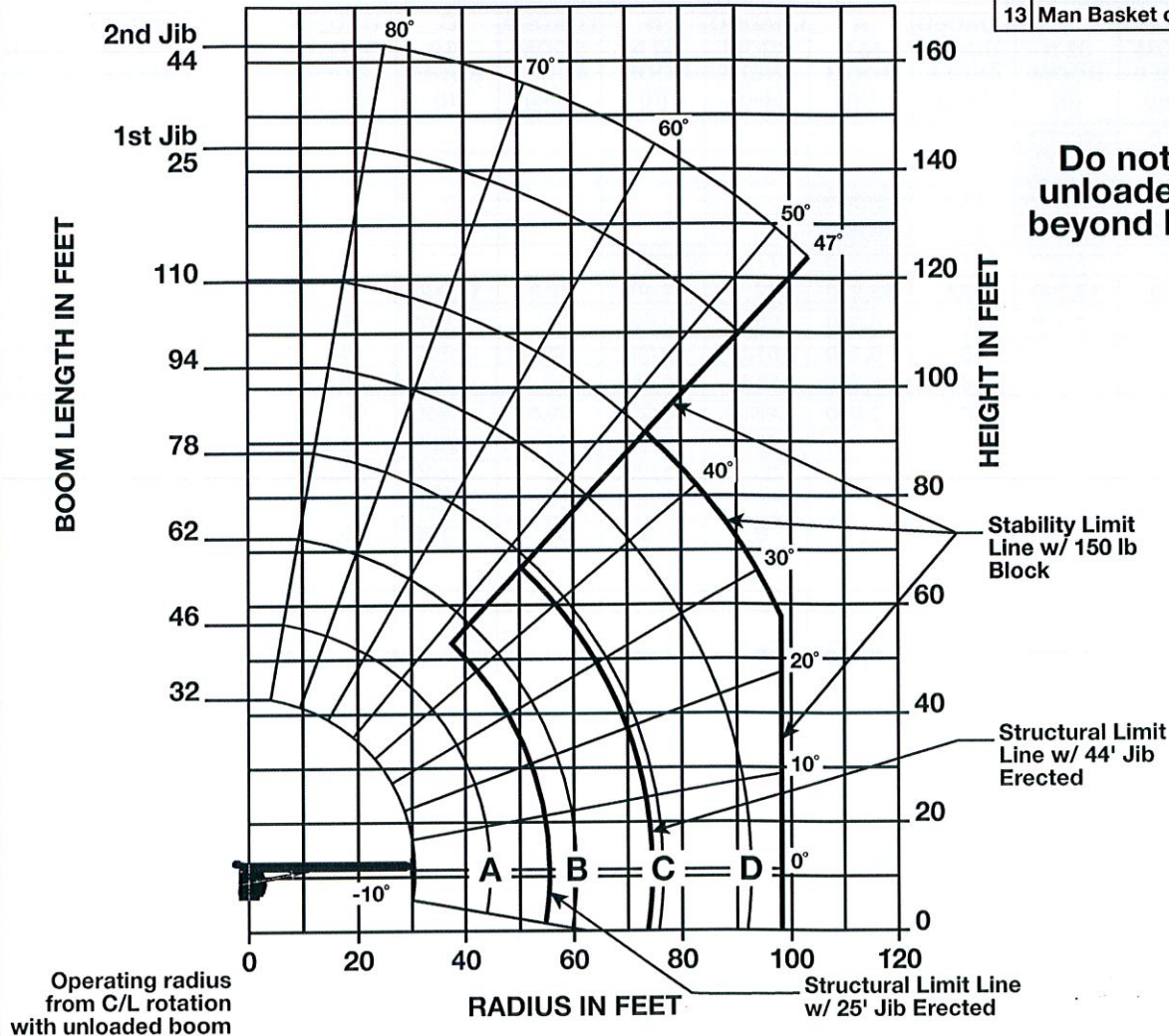

**Do not move
unloaded boom
beyond limit line.**

SET-UP

1. Fully extend and set outriggers to full span location, level crane and set optional front stabilizer, if equipped.

OPERATION

1. The 32 ft boom length capacities are based on boom fully retracted. If not fully retracted, do not exceed 46 ft boom length capacities.
2. Do not extend unloaded boom or jib beyond stability limit line on range chart as loss of stability may occur.
3. Load blocks and slings are considered to be a part of the load.
4. Operate with jib by radius when main boom is fully extended and by boom angle when main boom is partially extended. Do not exceed jib capacities at any partially extended boom length.
5. All jib loads must be lifted with single part reeving.

**13110A
110 ft BOOM
25 – 44 ft JIB**

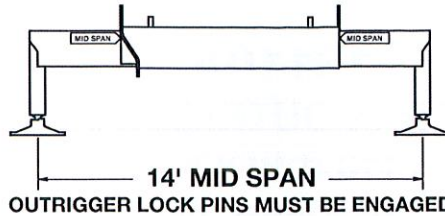

**MID SPAN
OUTRIGGER**

32 ft – 110 ft BOOM RATED LOADS WITHOUT JIB

LOADED RADIUS (ft)	LOADED BOOM ANGLE (deg)	32 ft BOOM (ft)	LOADED BOOM ANGLE (deg)	A 46 ft BOOM (ft)	LOADED BOOM ANGLE (deg)	B 62 ft BOOM (ft)	LOADED BOOM ANGLE (deg)	C 78 ft BOOM (ft)	LOADED BOOM ANGLE (deg)	D 94 ft BOOM (ft)	LOADED BOOM ANGLE (deg)	110 ft BOOM (ft)
5	78.5	30,000										
8	74.5	30,000										
10	70.5	30,000	77.5	29,100								
12	66.5	30,000	75	28,900								
15	60	24,300	71	24,000	77	20,000						
20	48.5	13,300	63.5	13,950	72	14,400	76.5	14,900				
25	34	8,350	56	8,900	66.5	9,600	72	9,600	76.5	10,000		
30			48	6,150	61.5	6,500	68.5	6,750	73	6,900	76.5	7,250
35			38.5	4,300	55.5	4,650	64	4,850	69.5	5,050	73.5	5,350
40			26.5	3,050	49.5	3,350	59.5	3,550	66	3,700	70.5	3,900
45					43	2,350	55	2,550	62.5	2,700	67	2,850
50					35	1,650	50	1,800	58.5	1,950	64	2,050
55					25	1,000	45	1,200	55	1,350	61	1,450
60					8	550	39	750	50.5	850	58	950
65											54.5	500
70												
	0	5,300	0	2,100	0	500						

25 – 44 ft JIB RATED LOADS

LOADED RADIUS (ft)	LOADED BOOM ANGLE (deg)	25 ft JIB (ft)	LOADED BOOM ANGLE (deg)	44 ft JIB (ft)
35	76.5	4,200		
40	75	4,100	76.5	2,500
45	73	2,650	75.5	2,500
50	71	1,800	74	2,500
55	69	1,200	72.5	2,000
60	66.5	700	70.5	1,400
65			68.5	950
70				

RATED LOAD REDUCTIONS WITH JIB

BOOM LENGTH (ft)	25 – 44 ft JIB STOWED
32	Reduce load 800 lb
46	Reduce load 600 lb
62	Reduce load 450 lb
78	Reduce load 350 lb
94	Reduce load 300 lb
110	Reduce load 250 lb

Note:

1. All capacities are in pounds, angles in degrees, and radii in feet.
2. Loaded boom angles are given as reference only.
3. Shaded areas are structurally limited capacities.
4. Handling of personnel is only permitted with full span extension of all outrigger beams

13110A
MID SPAN OUTRIGGER 14 ft
110 ft BOOM
25 – 44 ft JIB

LMI OPERATING CODE	
OPERATING MODE	
21	Main Boom – No Jib Stowed
22	Main Boom – Jib Stowed
23	25 ft Tele Jib
24	44 ft Tele Jib

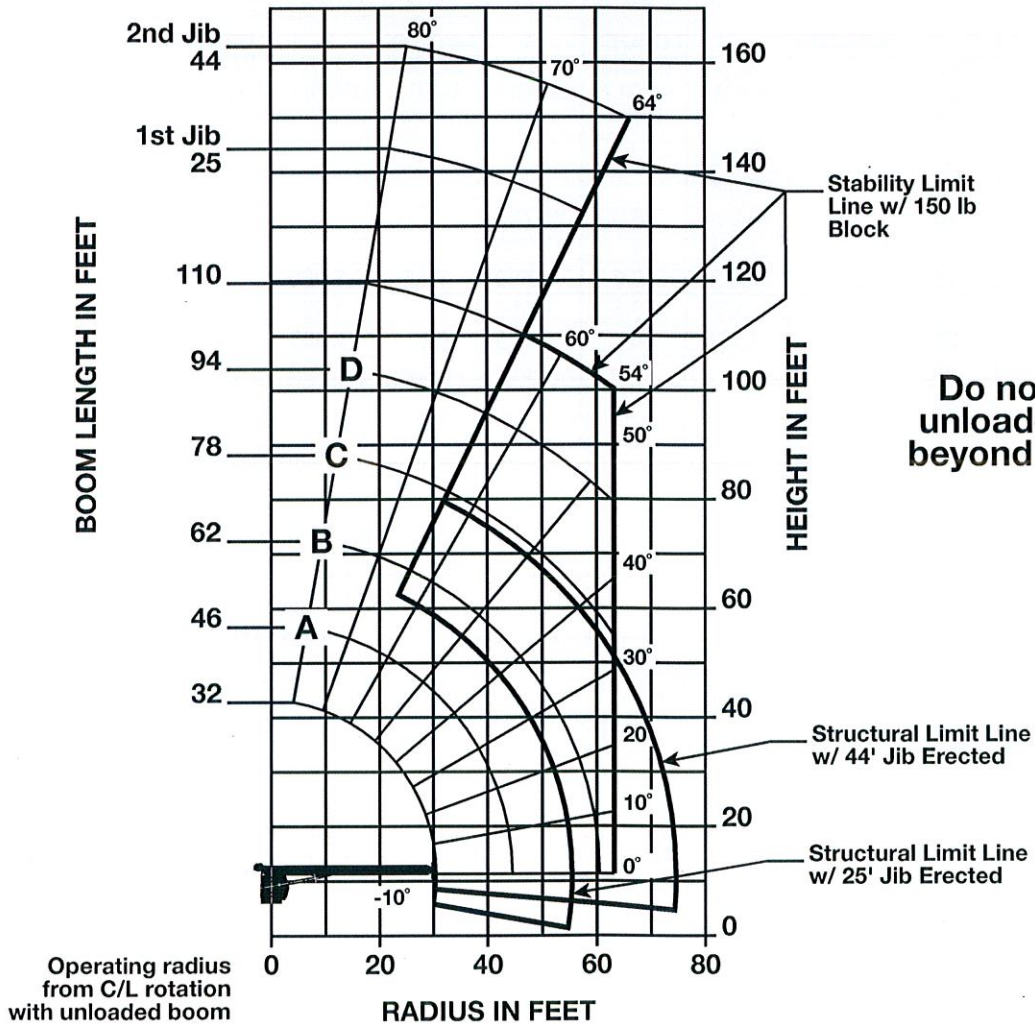

SET-UP

1. Engage mid span outrigger lock pins, extend and set outriggers to mid span location, level crane and set optional front stabilizer, if equipped.

OPERATION

1. The 32 ft boom length capacities are based on boom fully retracted. If not fully retracted, do not exceed 46 ft boom length capacities.
2. Do not extend unloaded boom or jib beyond stability limit line on range chart as loss of stability may occur.
3. Load blocks and slings are considered to be a part of the load.
4. Operate with jib by radius when main boom is fully extended and by boom angle when main boom is partially extended. Do not exceed jib capacities at any partially extended boom length.
5. All jib loads must be lifted with single part reeving.

**13110A
110 ft BOOM
NO JIB**

**RETRACTED
OUTRIGGER**

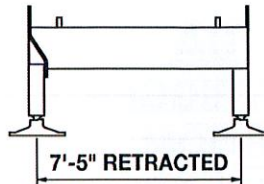

OUTRIGGER LOCK PINS MUST BE DISENGAGED

32 ft – 110 ft BOOM RATED LOADS WITHOUT JIB

LOADED RADIUS (ft)	LOADED BOOM ANGLE (deg)	32 ft BOOM (ft)	LOADED BOOM ANGLE (deg)	A 46 ft BOOM (ft)	LOADED BOOM ANGLE (deg)	B 62 ft BOOM (ft)	LOADED BOOM ANGLE (deg)	C 78 ft BOOM (ft)
5	78.5	30,000						
8	74	25,600						
10	70	16,000	76.5	16,750				
12	65	11,100	74	11,700				
15	60.5	7,000	70.5	7,500	75.5	7,850		
20	49.5	3,650	63.5	4,050	71	4,350	75.5	4550
25	35.5	1,750	56	2,150	66	2,400	71.5	2,600
30			47.5	950	60.5	1,200	67	1,350
35							63	550

RATED LOAD REDUCTIONS WITH JIB

Note:

1. All capacities are in pounds, angles in degrees, and radii in feet.
2. Loaded boom angles are given as reference only.
3. Shaded areas are structurally limited capacities.
4. Handling of personnel is only permitted with full span extension of all outrigger beams.

BOOM LENGTH (ft)	25 – 44 ft JIB STOWED
32	Reduce load 800 lb
46	Reduce load 600 lb
62	Reduce load 450 lb
78	Reduce load 350 lb
94	Reduce load 300 lb
110	Reduce load 250 lb

13110A
RETRACTED OUTRIGGER 7 ft 5 in
110 ft BOOM
NO JIB

LMI OPERATING CODE	
OPERATING MODE	
31	Main Boom – No Jib Stowed
32	Main Boom – Jib Stowed

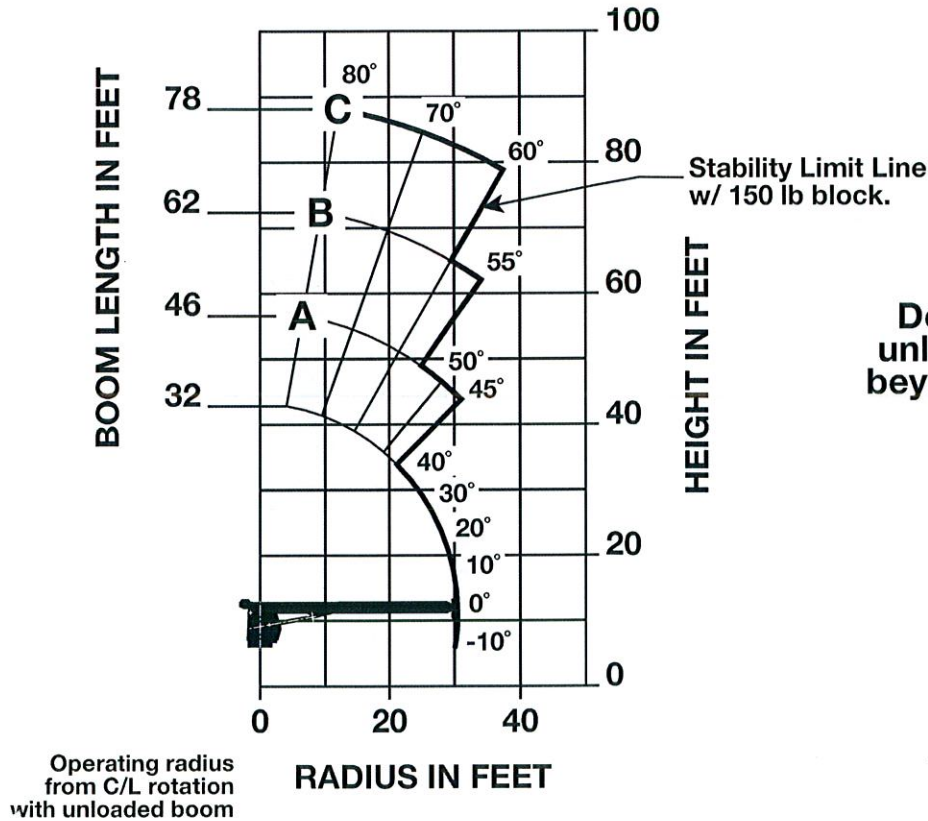

**Do not move
unloaded boom
beyond limit line.**

SET-UP

1. Set outriggers to retracted location, level crane and set optional front stabilizer, if equipped.

OPERATION

1. The 32 ft boom length capacities are based on boom fully retracted. If not fully retracted, do not exceed 46 ft boom length capacities.
2. Do not extend unloaded boom beyond stability limit line on range chart as loss of stability may occur.
3. Load blocks and slings are considered to be a part of the load.
4. Jib cannot be erected when using retracted outriggers.

DIMENSIONAL SPECIFICATIONS

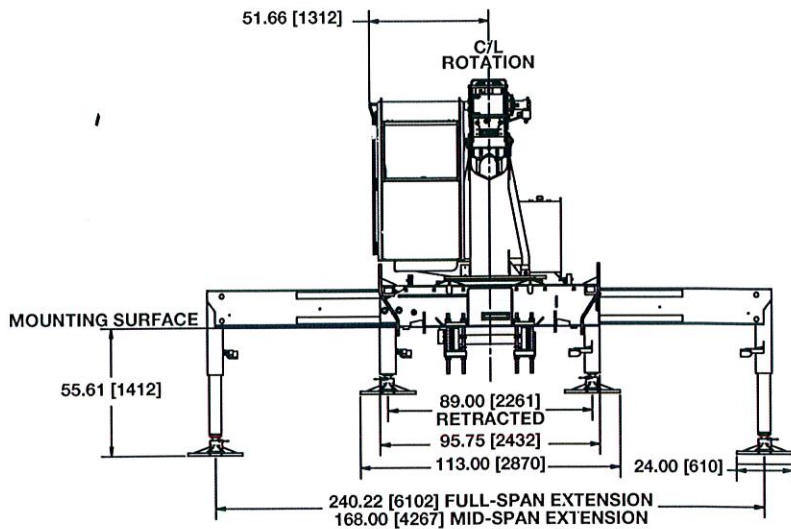
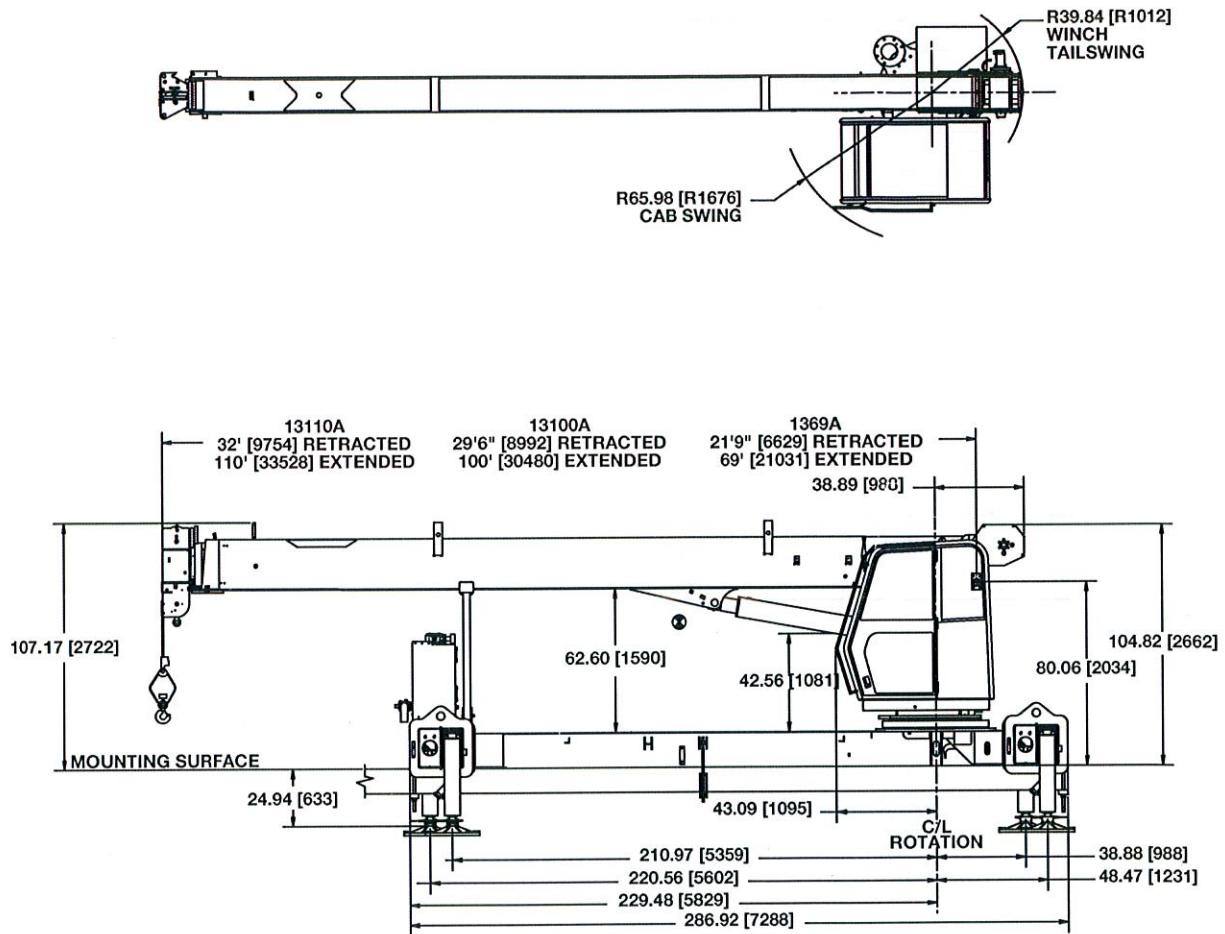

Notes:

1. Dimensions are in inches [mm] unless otherwise specified.