



LIFT ANYWHERE YOU NEED!



**UNI EN 12999
ANSI/ASME B30.5-2004**

 (ft/lbs)

SPD265 LOADING DIAGRAM

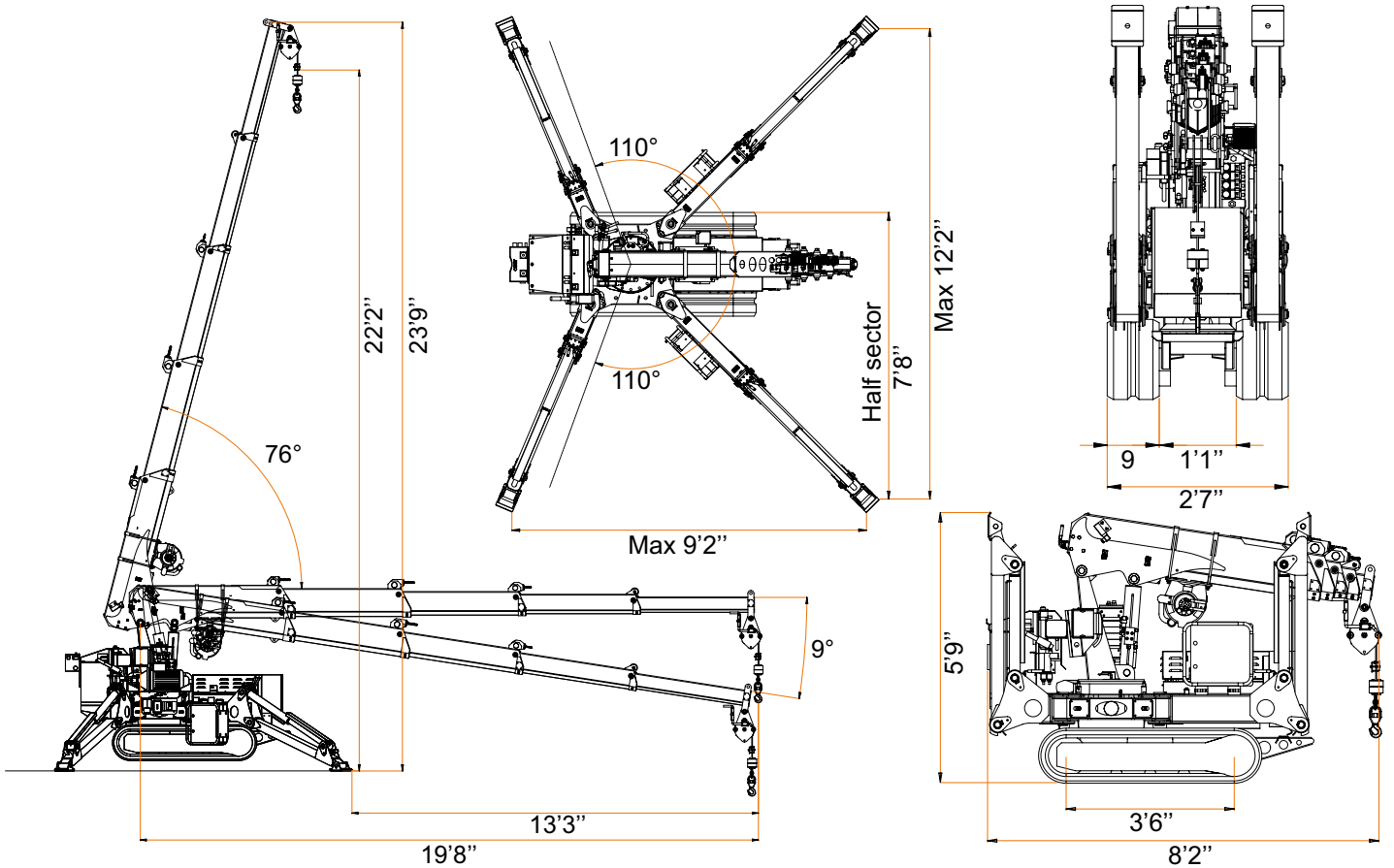
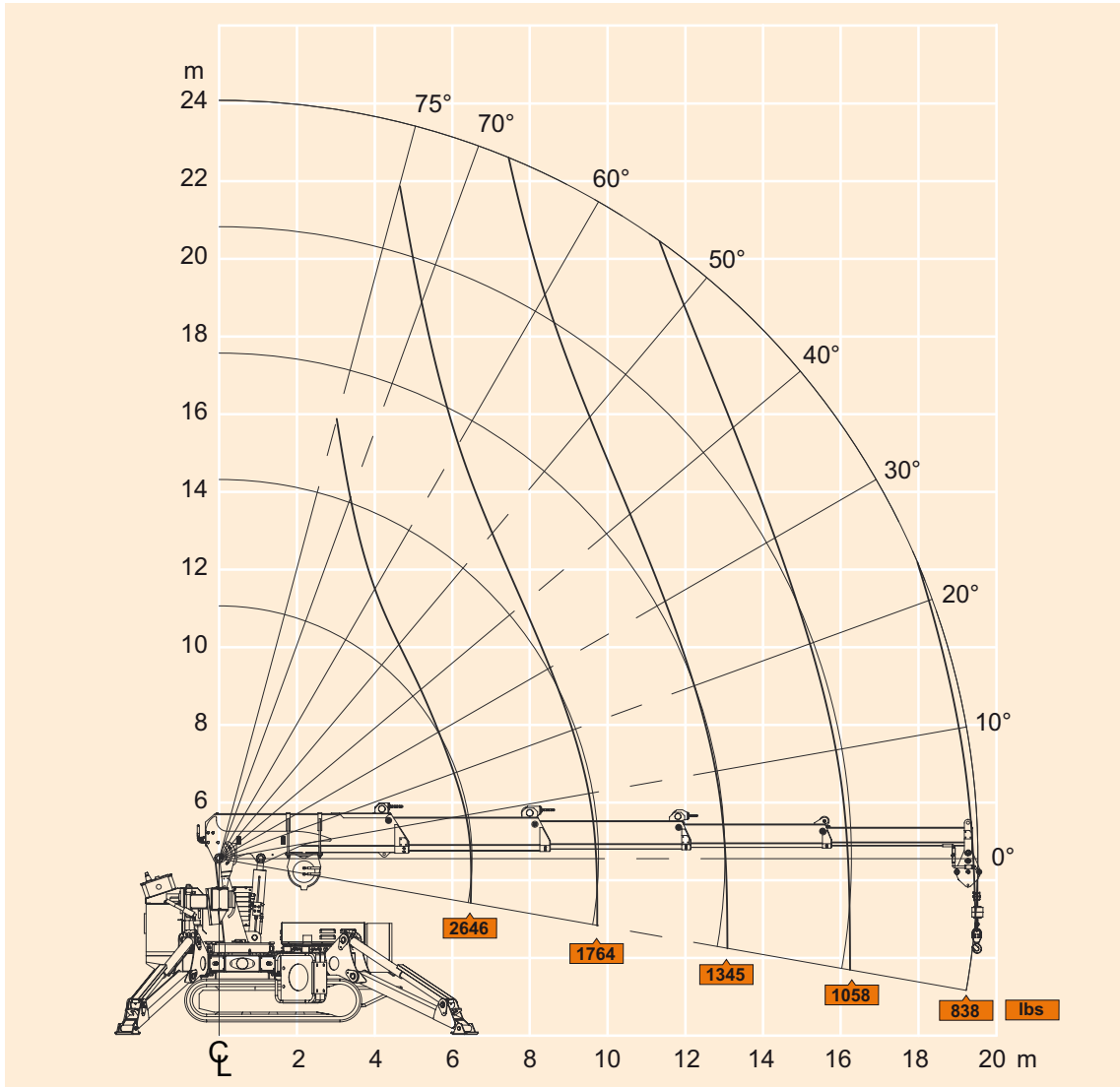

TECHNICAL SHEET

Dimensions	8'2" x 2'3" x 5'9"	ft
Weight	3750	lbs
Loading momentum	18,790	lbs-ft
Maximum SWL	2645	lbs
Maximum working radius	19'4"	ft
SWL at maximum working radius	840	lbs
Maximum working height	22'11"	ft
SWL at maximum working height	1874	lbs
Rotation	220	°
Tilting	-9/+76	°
Max SWL for winch-single fall	1322	lbs
Winch rope length	197	ft
Controls	electrical & proportional	
Drive system	hydrostatic	
Max gradient	20	°
Track area	3'6" x 9'	mm
Max track loading	4,84	PSI
Outriggers	hydraulic, multi position	
Max outrigger load	3086	Kg
Standard Equipment		
Stability control system (SCS), Manual emergency pump, Pressure relief valves, Overcentre lock valves, n°4 Outrigger pads, Battery charger, Remote control, Winch load limiter		
Optional Equipment		
3 Phase Kit, Colour, Working light, Double pulley, Manipulator MV300.3		
SPD 265 C+		
Motor	24 V-DC SEP	
Speed	4	
Battery capacity	n° 4 12V-120Ah	
Motor power	3	kW
Electrical system voltage	24	V

Notes: All specifications and features herein described can be changed without prior advice. All indicated data are indicative only and are not binding as crane performs differently depending on its use.

Note: Tutte le caratteristiche e le specifiche descritte possono essere soggette a variazioni senza preavviso. Tutti i dati riportati sono forniti a puro titolo informativo e non sono impegnativi dal momento che le prestazioni della macchina variano in funzione dell'utilizzo.

Hinweise: Unangekündigte Änderungen sämtlicher Eigenschaften und Daten sind möglich. Alle Angaben sind Richtwerte und nicht verbindlich da die Leistungen der Vorrichtung von deren Einsatz abhängen.

Notas: Todas las características y las especificaciones aquí indicadas pueden ser sujetas a variaciones sin aviso. Se dan todos los datos aquí indicados como simples informaciones. No se consideran como vinculantes, dado que las prestaciones del maquinario pueden variar.

Notes: Toutes les caractéristiques et les spécifications descriptives peut être sujet à variation sans préavis. Tout les données rapportés sont fournis à titre informatif et ne sont pas engageant au moment que la prestation de la machine change en fonction de l'emploi.

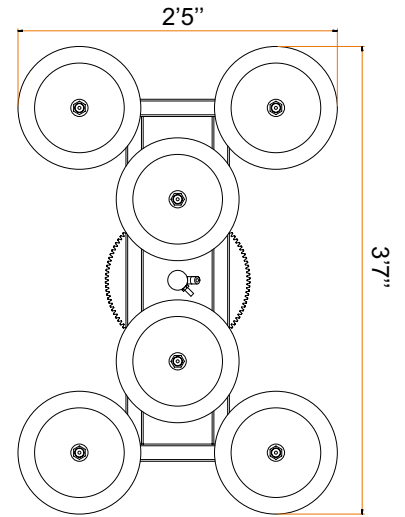
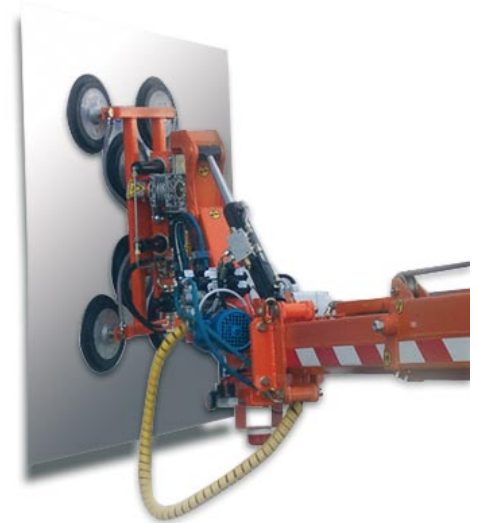
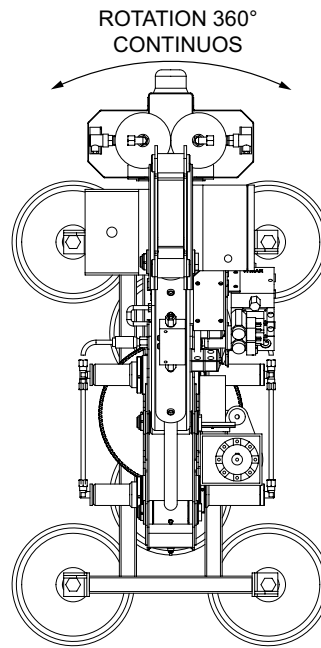
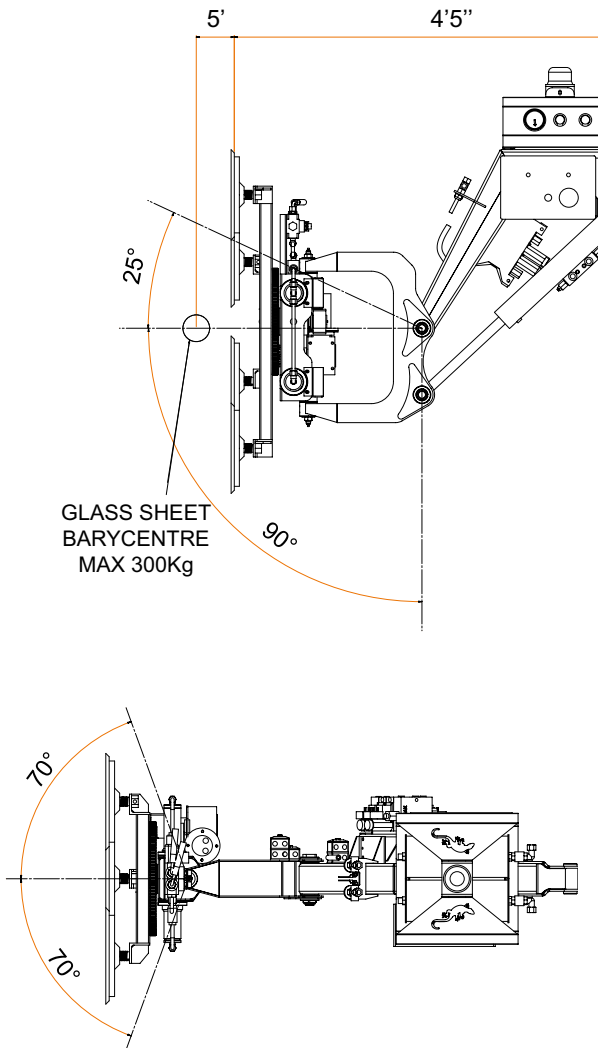

TECHNICAL SHEET

Dimensions	2' 5" x 3' 7" x 4' 5"	ft
Weight	310	lbs
Maximum SWL	660	lbs
Pads	6	n°
Pads Diameter	12"	in
Vacuum Pump	diaphragm pump	
Pump displacement	1.6	m ³ /h
Engine	24	V-DC
Power supply	from base machine	
Power	50	W
Controls	electrical & proportional	
Tilting	-90/+25	°
Slewing	±70	o
Rotation	360° (continuos)	Kg/cm ²
Safety devices - Double vacuum system - N°4 safety vacuum switches - Vacuum Indicator - Acoustic and optical alarm		