

# Series 500D: National Telescoping Crane

America's Leading Manufacturer of Truck-Mounted Hydraulic Cranes.

500D



National Pride



**NATIONAL CRANE**  
A Grove Worldwide Company



## Why Buy a National Series 500D?



- **16-ton Rating** – The new 500D provides a 16-ton capacity.
- **New 68-foot Three-section Boom** – The longest in its size range. The longer boom allows the operator to perform more lifts without the use of a jib, reducing setup time and improving efficiency.
- **Self-lubricating “Easy glide” Wear Pads** – The self-lubricating pads, standard on the 500D, reduce the conditions that cause boom chatter and vibration. The net result is smoother crane operation.
- **Internal Anti-two-block** – The patent-pending design, standard on the 500D, eliminates the external reel and wire. No more snagging the reel or wire on obstructions.
- **Adjustable Swing Speed** – A control knob located on the swing motor brake release valve can be easily adjusted to the crane operator’s swing speed preference.
- **Heavier Duty Torsion Box** – The stronger standard torsion box improves rigidity, reduces truck frame flex and eliminates the need for counterweight.
- **Quick-reeve Boom Tip and Sheave Blocks** – These standard features simplify rigging changes.
- **Pre-painted Components** – Painting crane components before assembly reduces the possibility of rust, improves serviceability and enhances the appearance of the machine.
- **Improved Serviceability** –
  - A removable winch allows the internal telescoping cylinder to be removed quickly, without dismantling the boom
  - Bearings on the boom extend and retract cables can be greased through access holes in the boom side plates.
  - Internal anti-two-block wire routing eliminates damage potential.
  - The boom sheave case is open, allowing access to replace the internal anti-two-block wire and to observe internal boom components.
  - Pre-paint reduces rust.
  - Internal boom parts have been reduced, decreasing service time when rebuilding the machine.
- **New State-of-the-art Control Valve** – Provides smoother operation. The new design eliminates parts, reducing repair costs and improving the machine’s serviceability.
- **National Crane Is the Market Leader** – National is number one in the production of commercial truck-mounted boom trucks. National has many programs and people directly and indirectly involved to provide our customers reliable products.
  - National has the boom truck industry’s leading test program. Every structural part of the crane is cycle tested up to 60,000 cycles at full capacity. In addition to cycle testing, each model is subjected to state-of-the-art strain gauge testing that measures metal deformation as small as one one-millionth of an inch. The net result is that weak areas are caught in test, not on job sites where costly downtime occurs.
  - All outrigger, lift and telescoping cylinders are manufactured by National Crane, so that the seals, packing glands, and end plates are traced for accurate shipment of replacement parts.
  - Parts are available for all National Crane machines, even if they are 35 years old.
  - National has a formalized quality program and is ISO 9001 approved.
- **National Crane is a Quality Product That Will Provide Years of Service.**

• 16-ton (14,51-t)  
maximum capacity

• 118-ft (35.97-m) maximum  
vertical reach\*

• 78-ft (23.77-m) maximum  
vertical hydraulic reach\*

• Hydraulic Capacity Alert  
system (HCA)

• Proportional boom  
extension

• High performance  
planetary winch

• Heavy-duty triple  
pump hydraulics

\* Maximum vertical reach is  
ground-level to boom tip  
height at maximum  
extension and angle with  
outriggers/stabilizers  
fully extended.



# 500D Capacities



## Load Rating Chart: Model 568D with 41-ft jib

Series 500D Load Rating Charts are available for all Model 538D, 547D, 560D and 568D cranes. National will send you a chart by FAX or mail on request - or you may secure needed load rating information through your nearest National dealer.

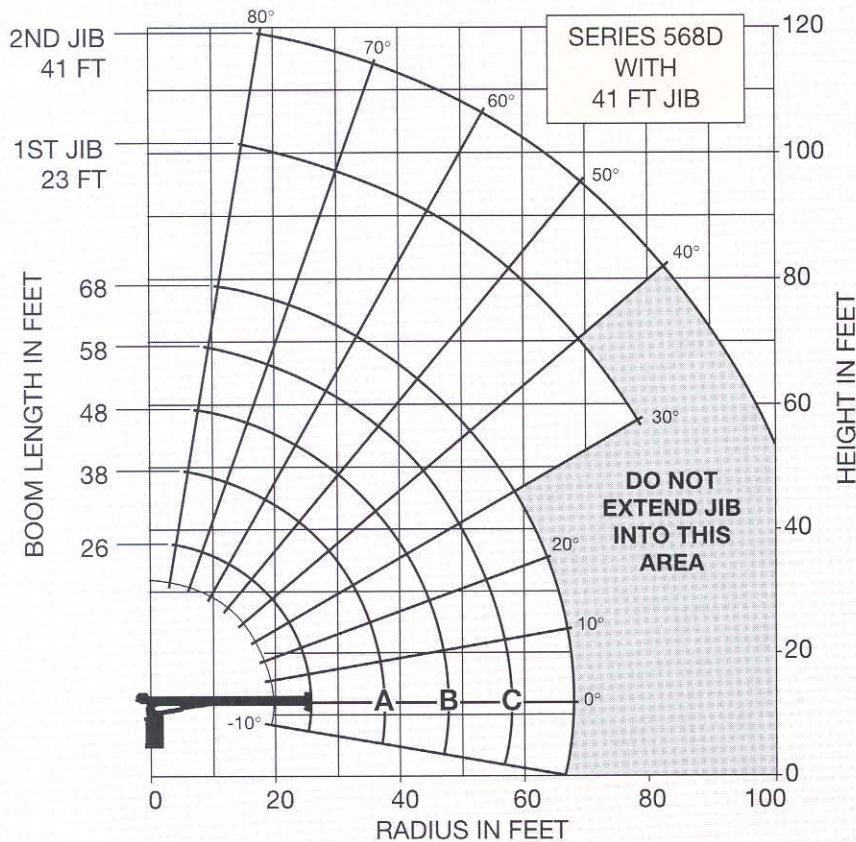

### Caution:

- Do not operate crane booms, jib extensions, any accessories or loads within 10 ft (3m) of live power lines or other conductors of electricity
- Jib and boom capacities shown are maximum for each section
- Do not exceed capacities at reduced radii
- Load ratings shown on the load rating charts are maximum allowable loads with the outriggers properly extended on a firm, level surface and the crane leveled and mounted on a factory-recommended truck
- Always level the crane with the level indicator located on the crane
- The operator must reduce loads to allow for factors such as wind, ground conditions, operating speeds and their effects on freely suspended loads
- Overloading this crane may cause structural collapse or instability
- Weights of any accessories attached to the boom or loadline must be deducted from the load chart capacities
- Do not exceed jib capacities at any reduced boom lengths
- Do not deadhead lineblock against boom tip when extending boom or winching up
- Keep at least three wraps of loadline on drum at all times
- Use only specified cable with this machine
- Maximum capacity with Burst-of-Speed is 3,000 lb (1361 kg) on single part line

## LOAD RATINGS

Load Radius (Feet)	Loaded Boom Angle	A			B			C			Load Radius (Feet)	Loaded Boom Angle	23 Ft. Jib (Lb)	Loaded Boom Angle	41 Ft. Jib (Lb)
		26 Ft. Boom (Lb)	Loaded Boom Angle	38 Ft. Boom (Lb)	Loaded Boom Angle	48 Ft. Boom (Lb)	Loaded Boom Angle	58 Ft. Boom (Lb)	Loaded Boom Angle	68 Ft. Boom (Lb)					
5	79.5	32,000													
8	72	19,750	78.5	17,900											
10	67	16,200	75.5	14,750	79	13,450									
12	62	13,750	72.5	12,500	76.5	11,450									
14	56.5	11,900	69	10,850	74	10,000	77.5	9,150							
16	51	10,500	65.5	9,600	71.5	8,850	75.5	8,300	78	8,000					
20	37.5	8,200	58.5	7,750	67	7,100	72	6,550	75	6,150					
25			49.5	6,200	60	5,750	66.5	5,250	70.5	5,000					
30			38	5,000	52.5	4,900	61	4,500	66	4,250					
35			22	3,800	44.5	4,000	55	3,900	61	3,600					
40					34	3,300	49	3,250	56	3,150					
45					19.5	2,600	41.5	2,850	50.5	2,750					
50							33	2,350	44.5	2,400					
55							21	1,900	37.5	2,050					
60									29	1,700					
65									17	1,300					
	0	4,000	0	2,350	0	1,500	0	950	0	650					

\*Shaded areas are structurally limited capacities.



# Mounting Configurations

The configurations are based on the Series 500D with an 85% stability factor. The complete unit must be installed in accordance with factory requirements and a test performed to determine actual stability and counterweight requirements since individual truck chassis vary.

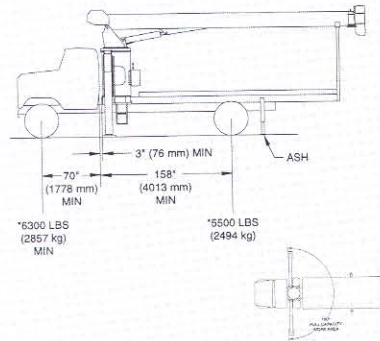

## Configuration 1 with Torsion Box

Working area	180°
Gross Axle Weight Rating Front	12,000 lb (5443 kg)
Gross Axle Weight Rating Rear	21,000 lb (9525 kg)
Gross Vehicle Weight Rating	33,000 lb (14 968 kg)
Wheelbase	228 in (579 cm)
Cab to Axle/trunnion (CA/CT)	158 in (401 cm)
Frame Section Modulus (SM) under crane: 110,000 PSI (758 MPa)	13.3 in <sup>3</sup> (218 cm <sup>3</sup> )
Frame Section Modulus (SM) over rear stabilizers: 110,000 PSI (758 MPa)	13 in <sup>3</sup> (213 cm <sup>3</sup> )
Stability Weight, Front	6,300 lb (2857 kg) minimum*
Stability Weight, Rear	5,500 lb (2494 kg) minimum*
Estimated Average Final Weight	25,900 lb (11 748 kg)

This configuration is the least expensive method for the Model 568D. This mount, with the crane mounted behind the cab, requires the least weight of all mounts for stability; thus, you can haul larger payloads on your truck. It requires standard subbase and rear (ASH) stabilizers.

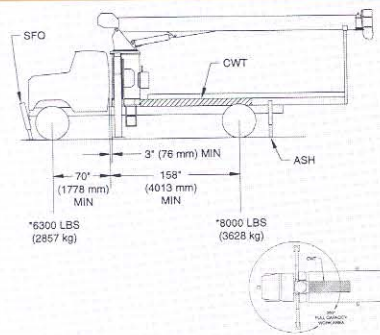

## Configuration 2 with Torsion Box

Working area	360°
Gross Axle Weight Rating Front	12,000 lb (5443 kg)
Gross Axle Weight Rating Rear	21,000 lb (9525 kg)
Gross Vehicle Weight Rating	33,000 lb (14 968 kg)
Wheelbase	228 in (579 cm)
Cab to Axle/trunnion (CA/CT)	158 in (401 cm)
Frame Section Modulus (SM) under crane: 110,000 PSI (758 MPa)	15.9 in <sup>3</sup> (261 cm <sup>3</sup> )
Frame Section Modulus (SM) over rear stabilizers: 110,000 PSI (758 MPa)	13 in <sup>3</sup> (213 cm <sup>3</sup> )
Stability Weight, Front	6,300 lb (2857 kg) minimum*
Stability Weight, Rear	8,000 lb (3628 kg) minimum*
Estimated Average Final Weight	27,600 lb (12 519 kg)

Requires front SFO stabilizer to give machine full capacity 360° around the truck. Truck must meet the minimum requirements above. Front stabilizer gives the machine a solid base, helping the operator control loads precisely. Requires front SFO and rear ASH stabilizers and subbase.

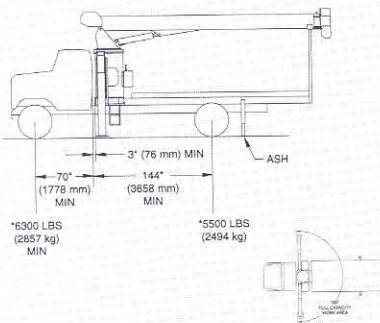

## Configuration 3 with Torsion Box

Working area	180°
Gross Axle Weight Rating Front	12,000 lb (4082 kg)
Gross Axle Weight Rating Rear	21,000 lb (15 422 kg)
Gross Vehicle Weight Rating	33,000 lb (19 504 kg)
Wheelbase	214 in (563 cm)
Cab to Axle/trunnion (CA/CT)	144 in (396 cm)
Frame Section Modulus (SM) under crane: 110,000 PSI (758 MPa)	13.3 in <sup>3</sup> (218 cm <sup>3</sup> )
Frame Section Modulus (SM) over rear stabilizers: 110,000 PSI (758 MPa)	13 in <sup>3</sup> (213 cm <sup>3</sup> )
Stability Weight, Front	6,300 lb (2857 kg) minimum*
Stability Weight, Rear	5,500 lb (2494 kg) minimum*
Estimated Average Final Weight	25,400 lb (11 521 kg)

Allows the installation of the Model 560D, 547D or 538D on a chassis with a small frame by using the standard sub-base for 18' bed. In most cases, the chassis will not require reinforcing, and the amount of counterweight required is minimized, increasing payload capacities.

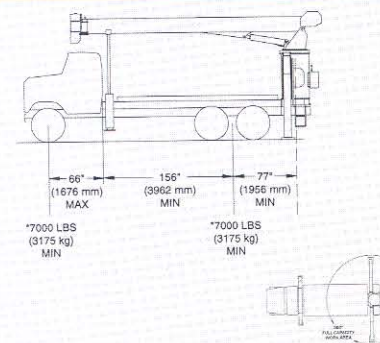

## Configuration 4 with Torsion Box - Rear Mount

Working area	360°
Gross Axle Weight Rating Front	9,000 lb (4082 kg)
Gross Axle Weight Rating Rear	34,000 lb (15 422 kg)
Gross Vehicle Weight Rating	43,000 lb (19 504 kg)
Wheelbase	222 in (563 cm)
Cab to Axle/trunnion (CA/CT)	156 in (396 cm)
Frame Section Modulus (SM) under crane: 110,000 PSI (758 MPa)	13.3 in <sup>3</sup> (218 cm <sup>3</sup> )
Frame Section Modulus (SM) over rear stabilizers: 110,000 PSI (758 MPa)	13.3 in <sup>3</sup> (218 cm <sup>3</sup> )
Stability Weight, Front	7,000 lb (3175 kg) minimum*
Stability Weight, Rear	7,000 lb (3175 kg) minimum*
Estimated Average Final Weight	29,800 lb (13 517 kg)

Advantages of a rear-mounted 500D: (1) allows operator to effectively use a close-in work area to lift heavier loads; and (2) 360° stability at full-rated load. Hydraulic stabilizers located behind the cab are necessary to keep the total weight of unit to a minimum with full stability. Requires front over-frame stabilizers, heavy-duty rear-mount subbase, air throttles and rear-mount plumbing.

### Notes:

- Gross Vehicle Weight Rating (GVWR) is dependent on all components of the vehicle (axles, tires, springs, frame, etc.) meeting manufacturers' recommendations; always specify GVWR when purchasing trucks
- Diesel engines require a variable speed governor and energize-to-run fuel solenoid for smooth crane operation; electronic fuel injection requires EET engine remote throttle

- All mounting data is based on a National Series 500D with an 85 percent stability factor
- The complete unit must be installed in accordance with factory requirements, and a test performed to determine actual stability and counterweight requirements per SAE J765; contact the factory for details
- Transmission neutral safety interlock switch is required with optional remote control

\*Estimated axle scale rates prior to installation of crane, stabilizers and subbase for 85% stability.



# Boom and Jib Combinations Data

Available in four basic models.

**Model 538D** — Equipped with a 16-38 ft (4.88-11.58 m) three-section boom. This model can be equipped with a 15 ft (4.57 m) single section jib or a 15-25 ft (4.57-7.62 m) two-section jib. Maximum tip height w/ 25ft (7.62 m) jib is 73 ft (22.25 m).

16-38 ft (4.88-11.58 m) three-section boom



16-38 ft (4.88-11.58 m) three-section boom



**5FJ15** 15 ft (4.57 m) jib

16-38 ft (4.88-11.58 m) three-section boom



**5FJ25M** 15-25 ft (4.57-7.62 m) two-section jib

**Model 547D** — Equipped with a 19-47 ft (5.79-14.33 m) three-section boom. This model can be equipped with an 18 ft (5.49 m) single section jib or an 18-29 ft (5.49-8.84 m) manual pull-out jib. Maximum tip height w/ 29 ft (8.84 m) jib is 86 ft (26.21 m).

19-47 ft (5.79-14.33 m) three-section boom



19-47 ft (5.79-14.33 m) three-section boom



**5FJ18** 18 ft (5.49 m) jib

19-47 ft (5.79-14.33 m) three-section boom



**5FJ29M** 18-29 ft (5.49-8.84 m) two-section jib

**Model 560D** — Equipped with a 23-60 ft (7.01-18.29 m) three-section boom. This model can be equipped with a 23 ft (7.01 m) single section jib or a 23-41 ft (7.01-12.50 m) two-section jib. Maximum tip height w/ 41 ft (12.50 m) jib is 110 ft (33.53 m).

23-60 ft (7.01-18.29 m) three-section boom



23-60 ft (7.01-18.29 m) three-section boom



**5FJ23** 23 ft (7.01 m) jib

23-60 ft (7.01-18.29 m) three-section boom



**5FJ41M** 23-41 ft (7.01-12.50 m) two-section jib

**Model 568D** — Equipped with a 26-68 ft (7.92-20.73 m) three-section boom. This model can be equipped with a 23 ft (7.01 m) single section jib or a 23-41 ft (7.01-12.50 m) two-section jib. Maximum tip height w/ 41 ft (12.50 m) jib is 118 ft (35.97 m).

26-68 ft (7.92-20.73 m) three-section boom



26-68 ft (7.92-20.73 m) three-section boom



**5FJ23** 23 ft (7.01 m) jib

26-68 ft (7.92-20.73 m) three-section boom



**5FJ41M** 23-41 ft (7.01-12.50 m) two-section jib

**Note:** maximum tip height is measured with outriggers/stabilizers fully extended.

5

## 500D Winch Data

- All winch pulls and speeds in this chart are shown on the third layer
  - Winch line pulls would increase on the first and second layers
  - Winch line speed would decrease on the first and second layers
  - Winch line pulls may be limited by the winch capacity or the ANSI 5 to 1 cable safety factor, shown below this chart
  - Hook blocks are rated at maximum capacity for the block.
- Do not exceed rated cable pull with any block.**

Winch	Cable Supplied	Average Breaking Strength	1 Part Line	2 Part Line	3 Part Line	4 Part Line	5 Part Line
			Lift and Speed	Lift and Speed	Lift and Speed	Lift and Speed	Lift and Speed
Standard Planetary Winch	9/16" Diameter Rotation Resistant	38,500 lb (17,463 kg)	7,700 lb (3 492.66 kg) 141 fpm (42.98 m/m)	15,400 lb (6 985.32 kg) 71 fpm (21.64 m/m)	23,100 lb (10 477.98 kg) 47 fpm (14.33 m/m)	30,800 lb (13 970.65 kg) 35 fpm (10.67 m/m)	32,000 lb (14 514.96 kg) 28 fpm (8.53 m/m)
	Optional 9/16" Diameter 6x25 IWRC	29,750 lb (13,494 kg)	8,400 lb (3 810.18 kg) 141 fpm (42.98 m/m)	16,800 lb (7 620.35 kg) 71 fpm (21.64 m/m)	25,200 lb (11 420.53 kg) 47 fpm (14.33 m/m)	32,000 lb (14 514.96 kg) 35 fpm (10.67 m/m)	NA NA
With "Burst-of-Speed"	Same as corresponding cable data shown above		3,000 lb (1 360.78 kg) 225 fpm (68.58 m/m)	6,000 lb (2 721.55 kg) 114 fpm (34.75 m/m)	9,000 lb (4 082.33 kg) 75 fpm (22.86 m/m)	12,000 lb (5 443.11 kg) 56 fpm (17.07 m/m)	15,000 lb (6 803.89 kg) 45 fpm (13.72 m/m)

Winch	Bare Drum Pull	Allowable Cable Pull
With standard rotation resistant rope	10,200 lb (4627 kg)	7,700 lb (3493 kg)
With optional 6x25 IWRC rope	10,200 lb (4627 kg)	8,400 lb (3810 kg)

Block Type	Rating	Weight
Downhaul Weight	3.85 ton (3.49 t)	150 lb (68 kg)
1 Sheave Block	11.55 ton (10.48 t)	200 lb (91 kg)
2 Sheave Block	19.25 ton (17.46 t)	355 lb (161 kg)



# Accessories

**Cabled Remote Controls** - A one-hand remote control is ideal where precise control and total load visibility are required.

- **Model R3** (lift, turn, telescope)
- **Model R4** (adds winch control)

**Radio Remote Controls** - Eliminate the handling and maintenance concerns that accompany cabled remotes. Operate to a range of about 250 feet (76 m), varying with conditions.

- **Model R3R** (R3R functions)
- **Model R4R** (R4R functions)

**One-Person Basket** - Strong but lightweight steel basket with 300-lb. (139-kg) capacity, gravity hung with swing lock and full body harness.

- **Model B1-S**
- **Model 2B1-S** (for dual locking baskets)

**Heavy-duty Personnel Basket** - 1,200-lb. (544-kg) capacity steel basket with safety loops for four passengers. Gravity leveling 72- x 42-inch (183- x 107-cm) platform. Fast attachment and secure locking systems. Load chart must show 2,300 lb (1043 kg) minimum to operate this accessory.

- **Model BSA-1**
- **Model BSA-R1** (provides rotation)

**Pallet Fork** - Manual leveling fork with adjustable throat and teeth, 4,400-lb. (1996-kg) capacity.

- **Model MKF**

**Loose Material Clam** - Moves up to 2/3 yard<sup>3</sup> (.50 m<sup>3</sup>) material. Bucket hooks easily to loadline and includes manual control hose reel.

- **Model LMC**

**Hydraulic Oil Cooler** - Automatic, self-contained radiator system with electric fans cools oil under continuous operation.

- **Model OC**

**Continuous Rotation** - Allows rotation of turret/boom without stop.

- **Model CR**

**Burst-of-Speed Winch** - Provides faster winch payout and pickup of unloaded cable. Increases line speed up to 60 percent over normal.

- **Model BOS**

## Dimensions Specifications:

All dimensions are in inches (mm) unless otherwise specified.

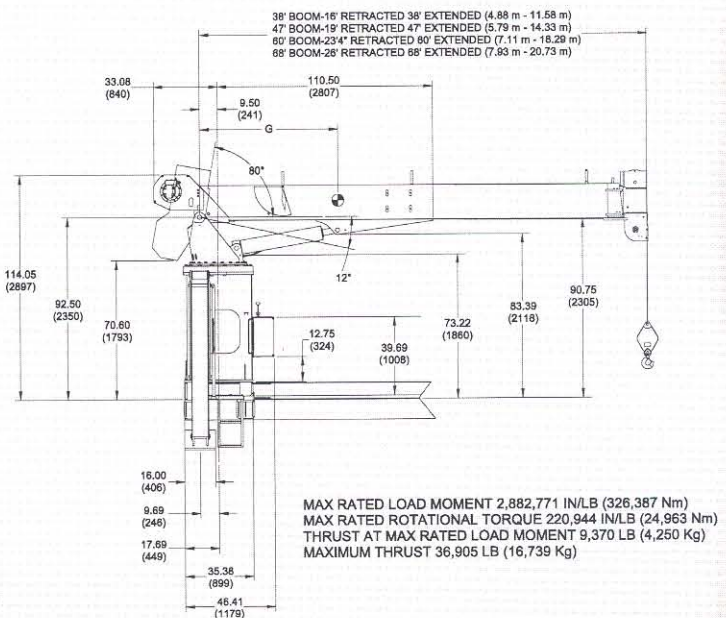
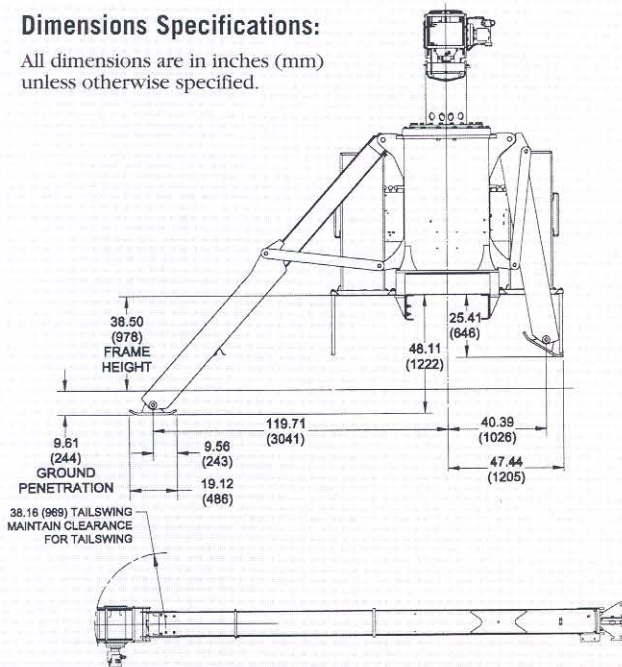

Your National Dealer:

National Crane is ISO 9001 Certified

**General Offices:**  
 11200 North 148th Street  
 Waverly, NE 68462 USA  
 Phone: (402) 786-6300  
 FAX: (402) 786-6363  
 Email: sales@nationalcrane.com  
 Web: www.nationalcrane.com

National Crane reserves the right to change designs, prices and specifications at any time without notice.  
 Printed in U.S.A. Form No. 500D/0800/5M/AA/JN