



“Big Red”

TX-280S / TX-300S / TX-330S

**Taylor Industrial Trucks
Standard Specifications**

TX-280S Rated Capacity 28,000-lbs. (**12,710 kg**)

TX-300S Rated Capacity 30,000-lbs. (**13,608 kg**)

TX-330S Rated Capacity 33,000-lbs. (**14,980 kg**)

24-in. (**610 mm**) Load Center

110-in. (**2,794 mm**) Wheelbase

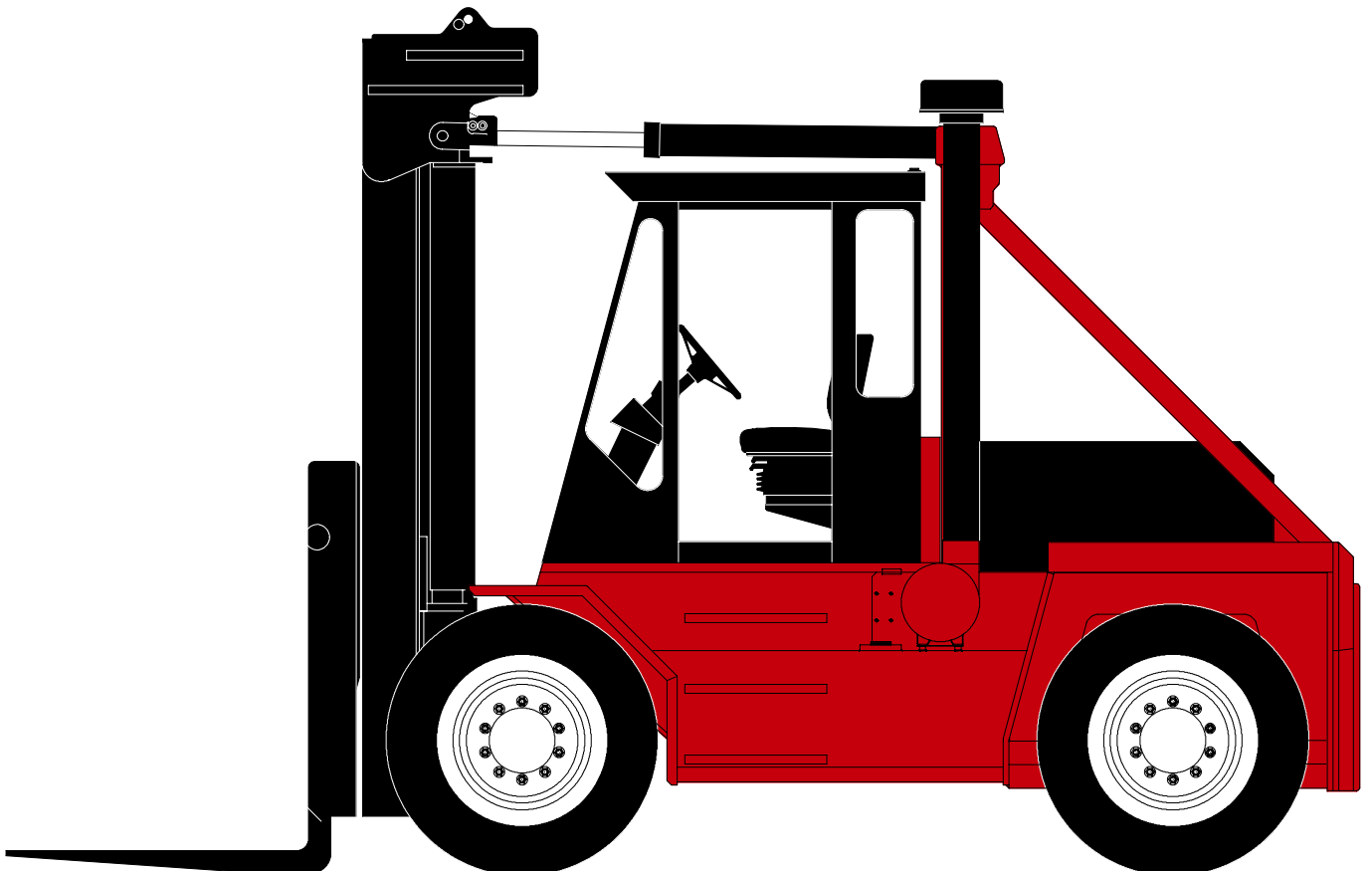

"Big Red" TX-280S / TX-300S / TX-330S

GENERAL	1.	Manufacturer	Manufacturer's Name	TAYLOR		TAYLOR		TAYLOR		
	2.	Model	Manufacturer's Designation	TX-280S		TX-300S		TX-330S		
				English	Metric	English	Metric	English	Metric	
	3.	Capacity	Rated Capacity	lb (kg)	28,000	12,710	30,000	13,608	33,000	14,980
	4.	Load Center	Distance	in (mm)	24	610	24	610	24	610
	5.	Power Type	Gas, LPG, Or Diesel		Diesel		Diesel		Diesel	
	6.	Tire Type	Cushion, Pneumatic Front / Rear		Pneumatic / Pneumatic		Pneumatic / Pneumatic		Pneumatic / Pneumatic	
	7.	Wheels	Number (X = Driven) Front / Rear		4X / 2		4X / 2		4X / 2	
DIMENSIONS	8.	Upright Lift	Standard Lift (Top Of Fork)	in (mm)	135.5	3,442	135.5	3,442	135.5	3,442
	9.	Forks	Thickness	in (mm)	3.5	89	3.5	89	3.5	89
	9.A		Width	in (mm)	8	203	8	203	8	203
	9.B		Length	in (mm)	48	1,219	48	1,219	48	1,219
	10.		Tilt Angle	Standard Upright - Forward / Backward	deg.°	15 / 12		15 / 12		15 / 12
	11.	Overall Dimensions	Length To Face Of Forks	in (mm)	174	4,419	174	4,419	174.5	4,432
	12.		Width (Standard Tires)	in (mm)	103	2,615	103	2,615	103	2,615
	13.		Height, Standard Upright Lowered	in (mm)	143	3,632	143	3,632	143	3,632
	14.		Height, Standard Upright Extended	in (mm)	209	5,308	209	5,308	209	5,308
	15.		Height To Top Of Counterweight	in (mm)	60	1,524	65	1,651	70	1,778
	16.		Height To Top Of A-Frame	in (mm)	126	3,200	126	3,200	126	3,200
	17.	Turning Radius	Minimum Outside	in (mm)	162	4,115	162	4,115	162	4,115
	17.A		Minimum Inside	in (mm)	10.5	267	10.5	267	10.5	267
	18.	Load Distance	Center Of Wheel To Face Of Forks	in (mm)	32.5	825	32.5	825	32.5	825
	19.	Aisle Width	(Add Load Length For 90° Stacking)	in (mm)	194	4,928	194	4,928	194.5	4,940
PERFORMANCE	20.	Stability	Comply With ANSI?		Yes		Yes		Yes	
	21.	Speeds	Travel Speed - Maximum Forward	mph (km/h)	17.4	28	17.4	28	17.4	28
	22.		Lift Speed - No Load	fpm (m/s)	71	.36	71	.36	71	.36
	22.A		Lift Speed - With Load	fpm (m/s)	68	.35	68	.35	68	.35
	23.		Lowering Speed - No Load / With Load	fpm (m/s)	75	.38	75	.38	75	.38
	24.	Drawbar Pull	Powershift (Maximum At Stall)	lb (kN)	26,260	117	26,200	117	26,100	116
	25.	Gradeability	Powershift (Maximum At Stall) No Load	%	30.5		30.6		32.9	
25.A	Powershift (Maximum At Stall) With Load		%	38.1		35.0		32.8		
WEIGHT	26.	Ttl. Apprx. Wt.	Standard Truck	lb (kg)	40,000	18,160	41,000	18,598	43,400	19,686
	27.	Axle Loading	Static With Rated Load - Front	lb (kg)	61,850	28,055	64,400	29,212	69,150	31,366
	27.A		Static With Rated Load - Rear	lb (kg)	6,150	2,790	6,600	2,994	7,250	3,289
	27.B		Static With No Load - Front	lb (kg)	19,450	8,823	19,000	8,618	19,200	8,709
	27.C		Static With No Load - Rear	lb (kg)	20,550	9,321	22,000	9,979	24,200	10,977
WHEELS / TIRES	28.	Tires	Number - Front / Rear		4 / 2		4 / 2		4 / 2	
	29.		Size - Front		12.00 x 20 - 18 PR		12.00 x 20 - 18 PR		12.00 x 20 - 18 PR	
	30.		Size - Rear		12.00 x 20 - 18 PR		12.00 x 20 - 18 PR		12.00 x 20 - 18 PR	
	31.	Wheelbase	Distance	in (mm)	110	2,794	110	2,794	110	2,794
	32.	Tread	Center Of Outside (Dual) Tires - Front	in (mm)	90	2,280	90	2,280	90	2,280
	32.A		Center Of Tires - Rear	in (mm)	80	2,030	80	2,030	80	2,030
	33.	Ground Clearance	No Load At Lowest Point	in (mm)	9	230	9	230	9	230
	34.		No Load At Center Of Wheelbase	in (mm)	14	356	14	356	14	356
	35.	Brakes	Service / Parking - Method Of Control		Foot / Hand		Foot / Hand		Foot / Hand	
	36.		Service / Parking - Method Of Operation		Hyd / Spring		Hyd / Spring		Hyd / Spring	
POWER UNITS / XMSN	37.	Battery	Volts / Ampere Hours (1 Battery)	V/Ah	12 / 1150		12 / 1150		12 / 1150	
	38.	Internal Combustion Engine	Make / Model		Cummins QSB6.7-C160		Cummins QSB6.7-C160		Cummins QSB6.7-C160	
	39.		Output - Intermittent Per SAE Standards	hp (kW)	160	119	160	119	160	119
	40.		Governed Speed - With Load	rpm	2200		2200		2200	
	41.		Cycle / Number Of Cylinders / Displacement	cu-in (L)	4 / 6 / 409	4 / 6 / 6.7	4 / 6 / 409	4 / 6 / 6.7	4 / 6 / 409	4 / 6 / 6.7
	42.	Clutch	Type		Inching		Inching		Inching	
	43.	Gear Change	Type		Hand		Hand		Hand	
	44.	Transmission	Number Of Speeds - Forward / Reverse		3 / 3		3 / 3		3 / 3	
	45.		Type		Powershift		Powershift		Powershift	
	46.	Relief Pressure	For Attachments	psi (bar)	2,000	138	2,000	138	2,000	138
47.		Width Across Counterweight And Front Fenders	in (mm)	95.5	2,426	95.5	2,426	95.5	2,426	
48.		Standard Fork Spread	in (mm)	84	2,134	84	2,134	84	2,134	
49.		Ground To Top Of Carriage	in (mm)	64.5	1,638	64.5	1,638	64.5	1,638	
50.		Load Moment	in-lbs (m-kg)	1,582,000	18,227	1,695,000	19,529	1,864,500	21,482	

† NOTE: Performance specifications are for trucks equipped as described on the back page of this specification sheet. Performance specifications are affected by the condition of the vehicle, its components, and the nature and condition of the operating area. If these specifications are critical, the proposed application should be discussed with your Taylor sales representative.

“Big Red” TX-280S / TX-300S / TX-330S

Mast Dimensions (inches / millimeters)						
2-Stage ULTRA-VU Telescopic Mast	Optional Lift Height (8)*		OAHL (13)		OAGR (14)	
	English	Metric	English	Metric	English	Metric
	135.5	3,442	143	3,632	209	5,308
	159.5	4,051	155	3,937	233	5,918
	183.5	4,661	167	4,242	257	6,528
*Includes Fork Thickness	219.5	5,575	185	4,699	293	7,442

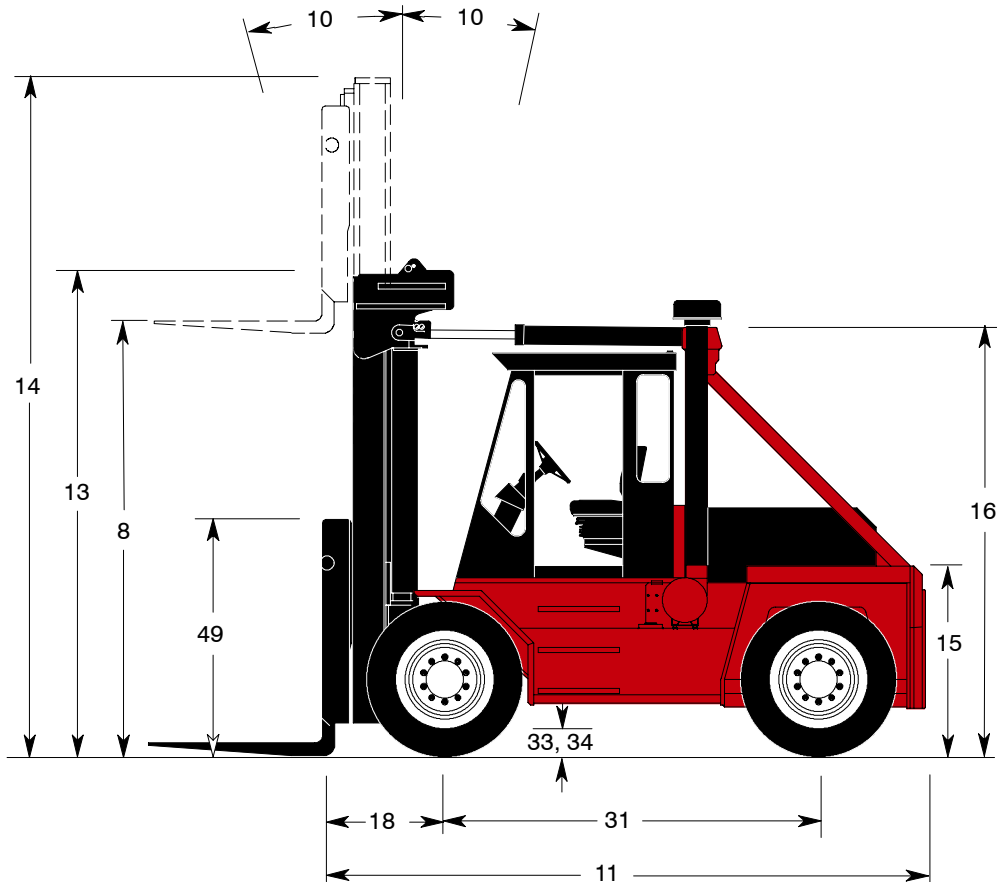
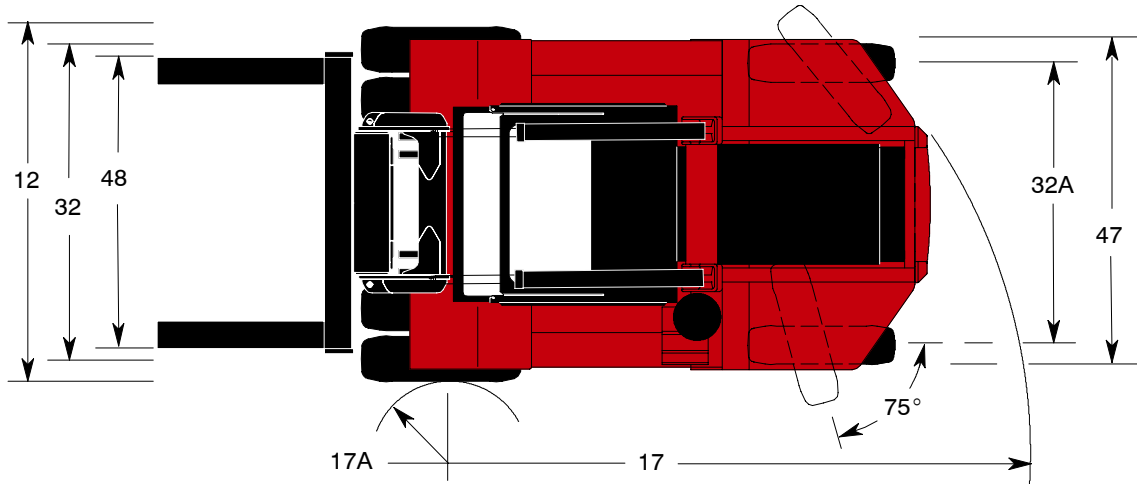

“Big Red” TX-280S / TX-300S / TX-330S

Engine

Cummins QSB6.7-C160 electronic turbocharged, charge air aftercooled (air to air) diesel, 6-cylinder diesel engine has 409 cu-in. (6.7 L) displacement. 4.09-in. (104 mm) bore x 5.2-in. (132 mm) stroke. Rated power of 160 (119 kW) horsepower at 2200 RPM. Maximum power of 165 horsepower (123 kW) at 2000 rpm. Peak torque 540 ft.-lbs. (732 N-m) at 1400rpm. (SAE J1995 Conditions). Standard features are electronic diagnostic and maintenance monitor, fuel/water separator and engine/transmission protection systems, fuel economy, and reduced emissions. Emission certification: US EPA Tier III, Carb Tier III, EU Stage III.

The fuel tank capacity is 53 gallons (201 L).

Air Cleaner

The dry type air cleaner has a safety element, restriction indicator, and vertical air intake extension.

Cooling System

The conventional top / bottom tank radiator has wide fin spacing to reduce dirt build-up and provide optimum engine cooling. Cooling includes engine charge air cooler, engine coolant air cooler, transmission oil air cooler, and a separate wet disc and hydraulic oil air cooler. Each can be serviced separately.

Electrical, Instrumentation, and Accessories

The one-piece instrument panel is pre-wired to accommodate heavy-duty accessories. All wiring is color and number coded.

The unit has a 12-volt electrical system with circuit breakers. Standard equipment includes a key-type anti-restart ignition switch system, 130-amp alternator, heavy-duty battery, electric fuel gauge, lighted display, electric horn, keyswitch-actuated amber strobe light, forward alarm, a reverse-actuated warning horn and 4 worklights (2 front and 2 rear).

Display indicates functions for seat belt, engine oil pressure, parking brake, battery indicator, and Tier III engine electronic diagnostic light package.

The unit has tilt steering and rear view mirrors.

All machine controls are Taylor Integrated Control Systems (TICS) using J1939 CANbus technology. This allows controllers and sensors to communicate with minimal wiring between the components. I/O modules are used to eliminate electromechanical relay devices and add reliability to the machine control system. J1939 CAN bus technology allows all machine data to be accessed through the main color display located in the cab. This display shows engine data along with warnings, and man/machine interface data. The display allows service personnel to access data needed during troubleshooting (such as sensor status and controller outputs). Machine functions can be tuned through the main display in the cab. Tuning functions are password protected to prevent operator access.

Transmission

The three-speed, fully reversing, modulated powershift transmission has inching, electric roll shift control, and a separate air-to-oil cooler. The filler pipe dipstick and large, heavy-duty oil filter are easily accessible. Automatic powershift (standard).

Drive Axle

The bolted heavy-duty planetary drive axle utilizes a hypoid ring gear and pinion. Positive rim mountings.

Steer Axle

The steer axle is a single hydraulic cylinder design with heavy-duty links from the cylinder ram directly to tapered roller bearing mounted spindles. Positive rim mountings.

Brake System

The internal force-cooled, hydraulic-actuated, wet disc, service brakes (and the hydraulic oil) are cooled by an air-to-oil cooler separate from the transmission cooler. The left pedal combines actuation of service brakes and transmission inching; the right pedal actuates the service brakes only. The parking brake control is mounted on the instrument panel.

Power Steering

The hydrostatic, steer-on-demand steering system provides constant response at all engine speeds.

Chassis

The all-welded frame has an integral counterweight. The hood slides on rollers. The cab is 2-door and includes one 40,000 BTU heater, one circulation fan, front and rear windshield wipers, front windshield washer, dome light, all glass tinted, door hold back latches with trip handles, grey insulation, and black floor mat inside cab. Cab color black only. The adjustable, vinyl covered air suspension seat with arm rest and orange seat belt is standard. The seat has $\pm 15^\circ / 20^\circ$ rotation.

Hydraulic System

The high-capacity hydraulic tank has a spin-on tank breather, wire-mesh strainers, and full-flow 10-micron return-line filters, with a replaceable element in the tank. Tank refill capacity is 49 gallons (185 L).

The hydraulic system utilizes a gear-type pump and sectional control valves. A tilt-lock valve reduces mast drift and torsional stress. The lift cylinders have self-adjusting packing. The standard joystick control lever is armrest mounted with multiple adjustments for operator comfort.

Mast, Carriage, and Rollers

The 11-ft. (3.4 m) ULTRA-VU telescopic, nested-channel mast, with two multiple-leaf lift chains, is constructed of high-strength steel. The double-acting lift cylinders are nested to the rear of the mast rails. Two lifting eyes and bolt-on caps permit safe, easy removal. The lift chains are nested in the mast rails and are hidden.

Pin-type 84-in. (2,134 mm) wide “C” carriage.

The mast and carriage main rollers are common and use shielded roller bearings. Chain rollers use sealed ball bearings. Side bearings are adjustable to compensate for wear.

Forks

The forks are pin-mounted and fully adjust from the outer carriage plates to the center brace. They are forged from heat treated steel and have square tips and bottom tapers. Sizes:

Size: 3.5-in. (89 mm) x 8-in. (203 mm) x 48-in. (1,219 mm)

This vehicle is certified to meet the applicable design and performance criteria required for Powered Industrial Trucks in OSHA Safety and Health Standards, Title 29 CFR, Part 1910.178, and the applicable design and performance requirements in ANSI B56.1 that were in effect at the time of manufacture. These standards also apply to the user and should be adhered to while operating this vehicle.

All specifications are subject to change without notice. Some operating data may be affected by the condition of the operating area. If these specifications are critical, contact the factory.

Note: Illustrations of equipment may sometimes show optional equipment not included on a standard model.