



TEREX®

HRM SERIES Hi-Ranger Overcenter Material Handling Aerial Device

AERIAL DEVICES

Terex® Hi-Ranger Aerial Devices are known throughout the industry. They come with a long history featuring quality and innovative design.

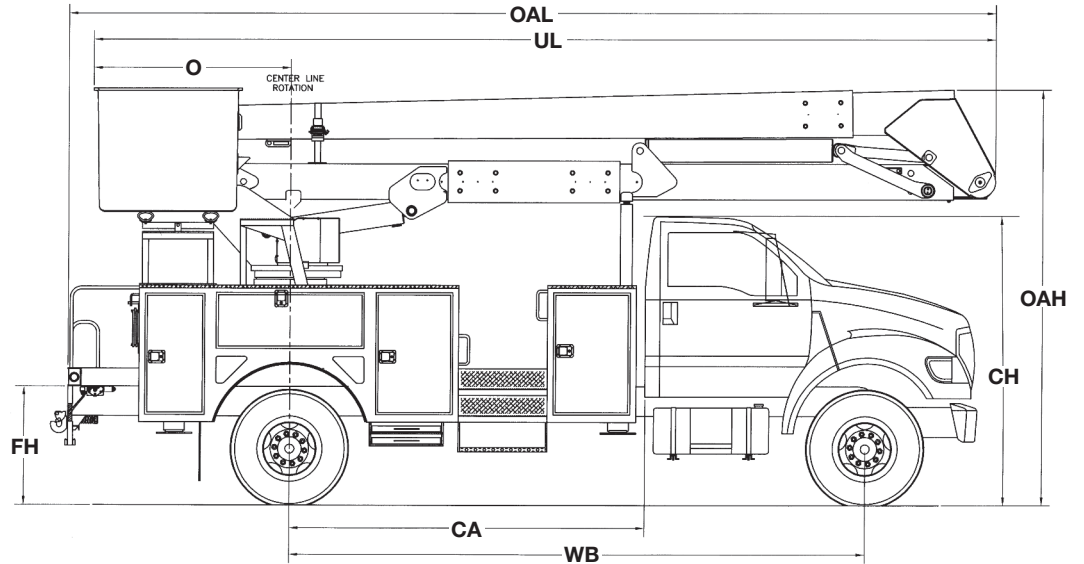

Measurements	HR42	HR46	HR50	HR52
	ORA	ORA	ORA	ORA
Typical Frame Height (FH)	40 in. (101.6 cm)	40 in. (101.6 cm)	40 in. (101.6 cm)	40 in. (101.6 cm)
Typical Cab Height (CH)	108 in. (274.3 cm)	108 in. (274.3 cm)	108 in. (274.3 cm)	108 in. (274.3 cm)
Offset (O)	50 in. (127 cm)	50 in. (127 cm)	50 in. (127 cm)	74 in. (188 cm)
Overall Height (OAH)	11' 3" (3.4 m)	11' 3" (3.4 m)	11' 8" (3.6 m)	11' 8" (3.6 m)
Overall Length (OAL)	22' 6" (6.9 m)	24' 2" (7.4 m)	26' 3" (8.0 m)	26' 4" (8.0 m)
Unit Length (UL)	20' 5" (6.2 m)	21' 11" (6.7 m)	24' 4" (7.4 m)	26' 4" (8.0 m)
Center of Rotation (H)	-	-	-	-
Cab to Axle (CA)	84 in. (213.4 cm)	108 in. (274.3 cm)	108 in. (274.3 cm)	108 in. (274.3 cm)
Wheel Base (WB)	153 in. (388.6 cm)	177 in. (449.6 cm)	177 in. (449.6 cm)	177 in. (449.6 cm)
Front Axle (FA)	8,000 lb. (3,629 kg)	9,000 lb. (4,082 kg)	10,500 lb. (4,763 kg)	10,500 lb. (4,763 kg)
Rear Axle (RA)	17,000 lb. (7,711 kg)	17,000 lb. (7,711 kg)	19,000 lb. (8,618 kg)	19,000 lb. (8,618 kg)
Gross Vehicle Weight Rating (GVWR)	25,000 lb. (11,340 kg)	26,000 lb. (11,793 kg)	29,500 lb. (13,381 kg)	29,500 lb. (13,381 kg)
Recommended Weight for Stability	13,500 lb. (6,124 kg)	15,000 lb. (6,804 kg)	22,000 lb. (9,979 kg)	23,000 lb. (10,433 kg)
Frame Section Modulus	18.0 in ³	18.0 in ³	18.0 in ³	18.0 in ³
Frame Yield Strength	50,000 psi	50,000 psi	50,000 psi	50,000 psi
Frame RBM	900,000 in-lbs	900,000 in-lbs	900,000 in-lbs	900,000 in-lbs



TEREX®

500 Oakwood Drive
PO BOX 1150
Watertown, SD 57201-6150
USA

Phone: (605) 882-4000
Facsimile: (605) 882-1842
www.terexutilities.com
E-mail: utilities.info@terex.com

Distributed By:

HRM SERIES

Hi-Ranger Overcenter Material Handling Aerial Device

STANDARD EQUIPMENT

- Side Mounted 24" x 30" x 42" One-Person Platform
- Platform Capacity of up to 600 lbs. (272.2 Kg)
- Control-Plus "3-D" Single Stick at Platform
- Safety Harness With Attached Lanyard
- Continuous Unrestricted Worm Gear Rotation
- Category "C" Rating Per ANSI A92.2
- Rectangular, Bi-Axial Epoxy Resin, Filament Wound Fiberglass Booms
- Individual Lever Lower Controls
- Hydraulic Platform Rotator
- Hydraulic Platform Tilt at Upper and Lower Controls
- Hydraulic Lower, Mechanical Upper Platform Leveling System
- Two Speed Throttle Control at Upper Controls
- Full Pressure, Open-Center Hydraulic System
- 35 Gallon Hydraulic Oil Reservoir
- Padded Boom Rest with Upper Boom Tie Down
- Boom Interlock
- Moving Outrigger Alarm
- Truck Level Indicator

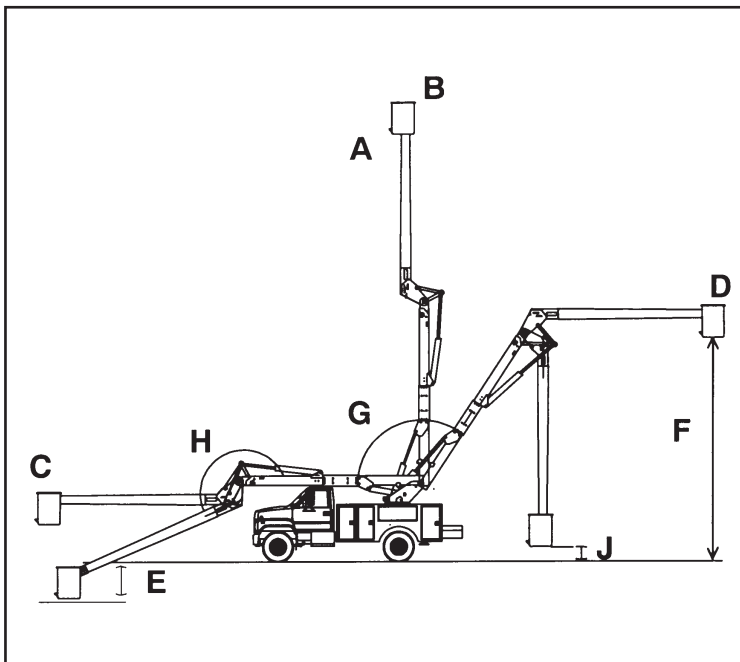

CAPACITIES & DIMENSIONAL DATA (Based on a 40 Inch Frame Height)

	Bottom of Platform Height (A)	Working Height (B)	Side Reach (C)	Lower Boom Full Up Upper Boom 0° (D)	Bottom of Platform to Ground Level (E)	Bottom of Platform to Ground (F)	Bottom of Platform to Ground (J)	Lower Boom Articulation (G)	Upper Boom Articulation (H)
HR42	42.5 ft (13.0 m)	47.5 ft (14.5 m)	36.1 ft (11.0 m)	33.9 ft (10.3 m)	41.0 in (104 cm)	23.0 ft (7.0 m)	25 in (63.5 cm)	120°	197°
HR46	45.5 ft (13.9 m)	50.5 ft (15.4 m)	38.6 ft (11.8 m)	36.6 ft (11.2 m)	25 in (64 cm)	24.3 ft (7.4 m)	23 in (58.4 cm)	120°	193°
HR50	50.0 ft (15.2 m)	50.0 ft (16.8 m)	43.4 ft (13.2 m)	33.6 ft (10.2 m)	41.0 in (104 cm)	28.8 ft (8.8 m)	55 in (140 cm)	103°	200°
HR52	52.0 ft (15.8 m)	57.0 ft (17.4 m)	45.4 ft (13.8 m)	35.6 ft (10.9 m)	48.0 in (122 cm)	28.8 ft (8.8 m)	31 in (78.7 cm)	103°	200°

OPTIONAL EQUIPMENT

- Various Side Mount Platforms
- Various Platform Covers
- Liners With or Without Steps
- 24" Platform Lifter
- Jib Options
 - Hydraulic Jib Extension Systems
 - Hydraulic Articulating Jib/Winch, Side Mt. 1500 lbs.
 - Single Wire/46 Kv Insulated Single Line Lifter / Multi-Phase Attachments
- Category "B" Rating per ANSI A92.2
- Lower Boom Lifting Eye
- Automatic Boom Latch
- Hydraulic Tool Outlets
- Engine Stop/Start
- Auxiliary Power
- Auxiliary Let Down System
- Demand Throttle
- Boom Overstow Protection
- Boom/Boom Stow Interlock
- Boom Storage Warning Light
- Outrigger Sag Light
- Various Types of Outriggers
- Truck Grounding Cable & Clamp
- Hybrid Enable
- HyPower™ Hybrid System by Terex®

Effective Date: March, 2010. Product specifications and prices are subject to change without notice or obligation. The photographs and/or drawings in this document are for illustrative purposes only. Refer to the appropriate Operator's Manual for instructions on the proper use of this equipment. Failure to follow the appropriate Operator's Manual when using our equipment or to otherwise act irresponsibly may result in serious injury or death. The only warranty applicable to our equipment is the standard written warranty applicable to the particular product and sale and Terex makes no other warranty, express or implied. Products and services listed may be trademarks, service marks or trade-names of Terex Corporation and/or its subsidiaries in the USA and other countries. All rights are reserved. Terex® is a registered trademark of Terex Corporation in the USA and many other countries. Copyright 2010 Terex Corporation.