



GROVE[®] TM 375

HYDRAULIC CRANE with TRAPEZOIDAL[†] BOOM

30 TON CAPACITY

72.5-TONS METRIC

[†] Patented Grove feature



CONSTANT IMPROVEMENT AND ENGINEERING PROGRESS MAKE IT NECESSARY THAT WE RESERVE THE RIGHT TO MAKE SPECIFICATION, EQUIPMENT AND PRICE CHANGES WITHOUT NOTICE. ILLUSTRATIONS SHOWN MAY INCLUDE OPTIONAL EQUIPMENT AND ACCESSORIES AND MAY NOT INCLUDE ALL STANDARD EQUIPMENT. OPTIONAL EQUIPMENT IS DESIGNATED BY (*) IN SPECIFICATIONS FOLDER.



30,000 lbs. @ 152' TIP HEIGHT
(13 608 kg) (46.3 m)

With 88' jib
7,630 lbs. @ 206' TIP HEIGHT
(3461 kg) (62.8 m)

50,000 lbs. @ 120' TIP HEIGHT
(22 680 kg) (36.6 m)

THE GROVE TRAPEZOIDAL BOOM

A Long Reach Boom of Superior Strength and Capacity.

The Grove Trapezoidal Boom presents the optimum strength-to-weight ratio for hydraulic crane operation and is the proven performer among high capacity long reach booms. More crane users have placed their trust in the Grove design than in any other . . . more than 95% of the 80-ton and over hydraulic cranes sold in the U.S. are Groves. It's the boom that gives the user more reach, more long boom capacity and greater profitability for his investment.

The four-section boom provides a tip height of 120' (36.6 m) and is available with a power-pinned fly section (standard) or a full-power fly.

† Patented Grove feature

BOOM EXTENSION AND JIB

A 32' (9.7 m) "Swingaway" lattice extension which stows laterally along-side the boom base section swings quickly into working position to provide a tip height of 152' (46.3 m). Additional inserts may be added to create an 88' (26.8 m) jib reaching to a tip height of 206' (62.8 m). The jib is cable suspended and offset from a minimum of 5° to a maximum of 30°.

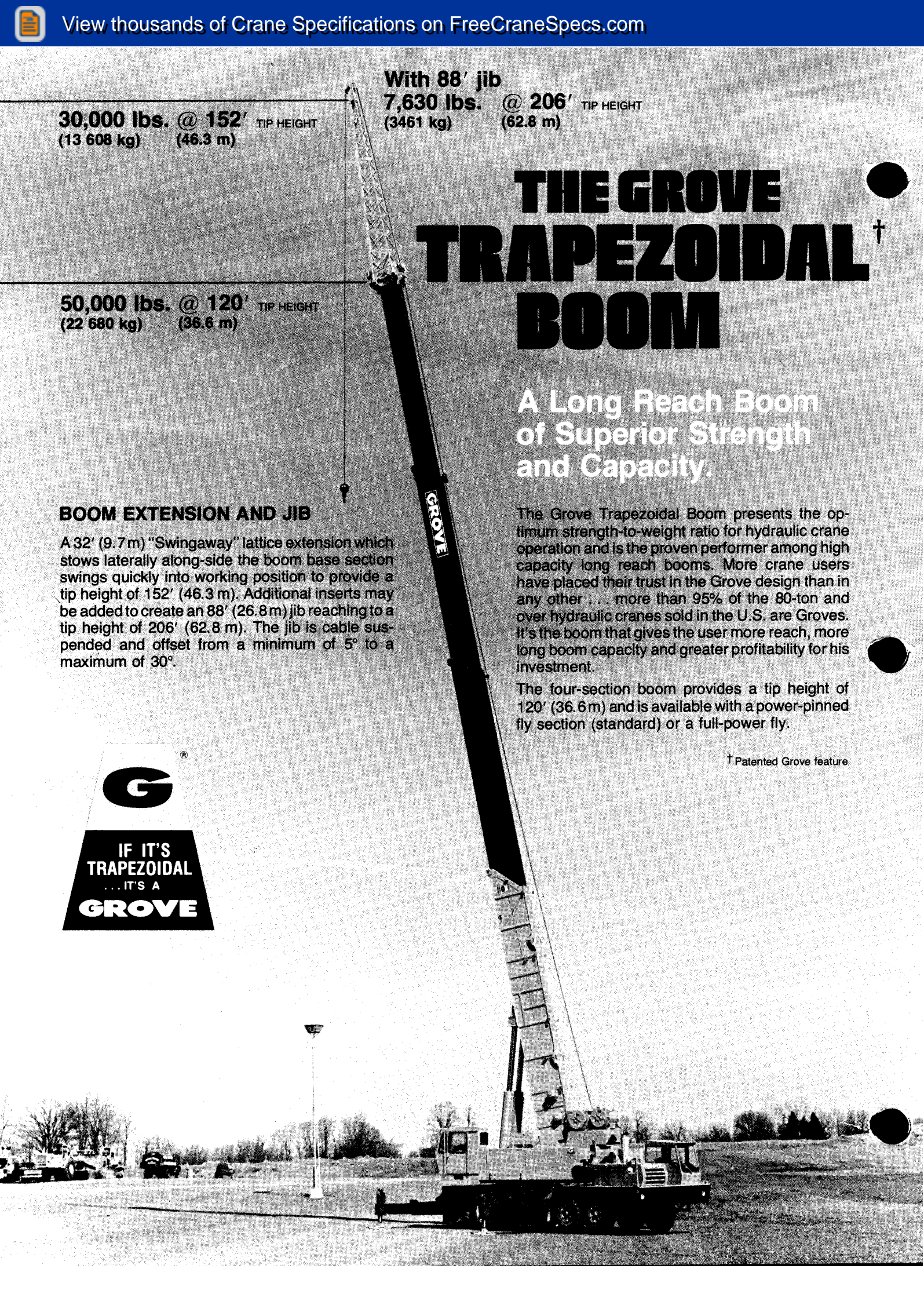
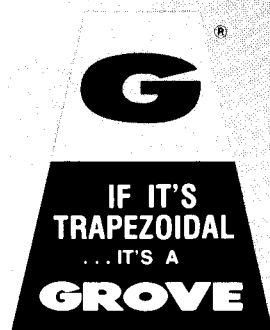

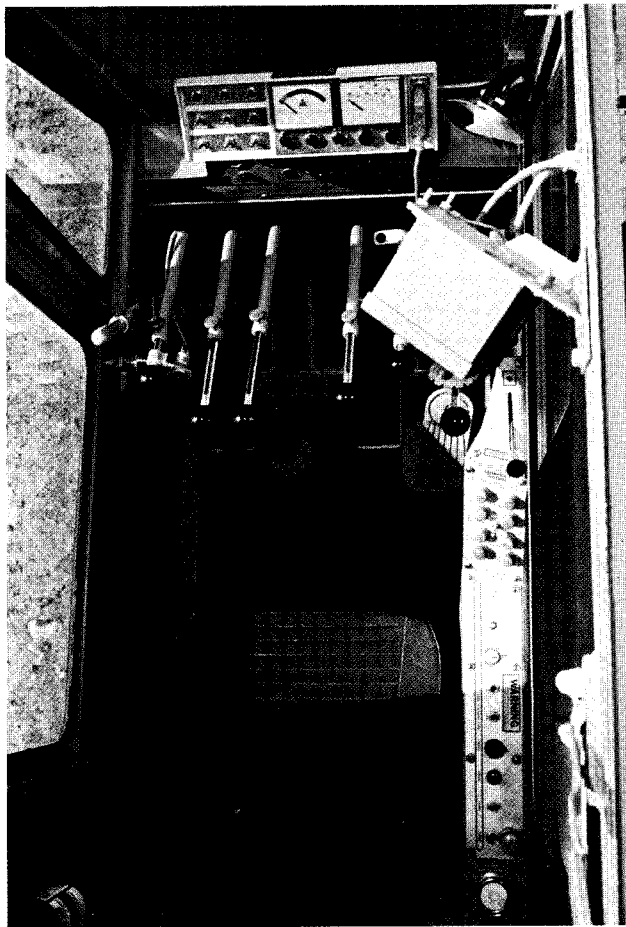

OPERATOR CONVENIENCE AND SAFETY

... are features of the all-steel, acoustically treated cab. When the skylight is raised and the windshield removed, there are no overhead crossmembers to interfere with visibility. Other features include adjustable full length control levers, adjustable operator's seat with headrest, complete engine controls and instrumentation, sliding door, laminated safety glass, electronic boom angle indicator and sight leveling bubble.

LOAD MOMENT AND ANTI-TWO BLOCK SYSTEM

measures critical operational factors relative to rated capacity and gives the operator a continuous visual display of conditions for the load.

An easy-to-read gauge indicates the approach of an overload or two-block condition and should overload or two-block occur, an audio-visual warning alerts the operator; the Grove "control lever lockout system" returns the controls to neutral and permits the use of only those crane functions that will correct the condition.

GROVE TWO-SPEED HOIST

... The standard main hoist is the model 32S-1726B, a Grove designed and manufactured two-speed hoist which permits both high line-pull and high line-speed without changes in lagging or gearing. At the flick of the electro-hydraulic switch, the operator can change from maximum line-pull (16,800 lbs.) (7621 kg) to top line-speed (560 FPM) (170 m/min).

GROVE EXTENDIBLE COUNTERWEIGHT†

is hydraulically extended to working position to provide improved capacities with a minimum of weight. Power installed and removed, it is also equipped with a travel lock.

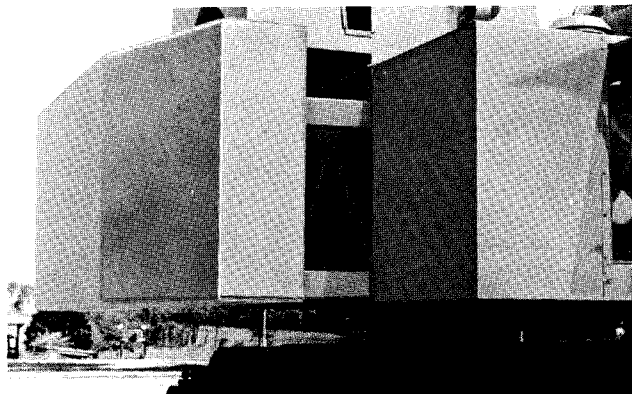
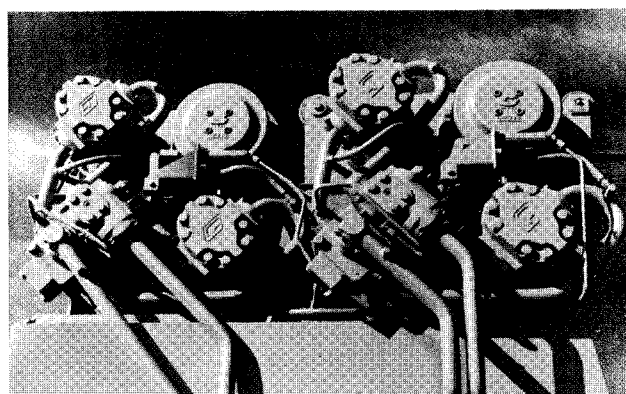

Meets requirements of P.C.S.A. Standard No. 2

† The Trapezoidal Boom, Two-Speed Hoist, Extendible Counterweight and Vertical Jack Lock are patented Grove features.

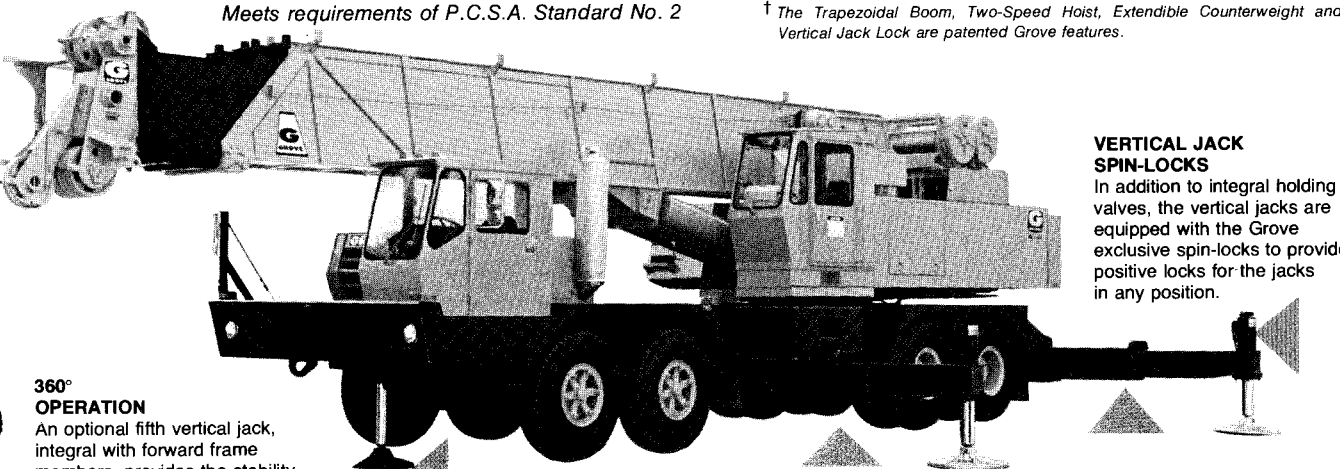

360° OPERATION

An optional fifth vertical jack, integral with forward frame members, provides the stability for 360 degree lifts. It is equipped with an integral holding valve.

VERTICAL JACK SPIN-LOCKS

In addition to integral holding valves, the vertical jacks are equipped with the Grove exclusive spin-locks to provide positive locks for the jacks in any position.

TWO-STAGE TELESCOPING OUTRIGGERS

Double box two-stage telescoping beam outriggers with integral welded boxes and removable beams extend to 25 ft. 5 1/4 in. (7.8 m), greatly increasing the working radii of the carrier.



SUPERSTRUCTURE SPECIFICATIONS

BOOM – 36 ft. – 146 ft. (11 m – 44.5 m) total length; 4-section Trapezoidal main boom consisting of base section, 2 full-power sections to 88 ft. (26.8 m), power-pinned section to 114 ft. (34.8 m) and a 32 ft. (9.7 m) "Swingaway" lattice boom extension (2° offset).

***FULL-POWER BOOM** – 36 ft. – 146 ft. (11 m – 44.5 m) total length; 4-section Trapezoidal main boom consisting of base section, 3 full-power sections to 114 ft. (34.8 m) and a 32 ft. (9.7 m) "Swingaway" lattice boom extension (2° offset).

Each boom has individually controlled telescope sections supported on graphite impregnated Nylatron wear pads. Integral check valves on each telescoping cylinder [6½ in. (165 mm) bore].

BOOM NOSE – Six 15 in. (381 mm) tread diameter sheaves mounted on heavy-duty tapered roller bearings. Removable pin-type rope guards allow easy reeving. Rope dead-ends on each side of boom nose.

***AUXILIARY BOOM NOSE** – Single 15 in. (381 mm) tread diameter sheave mounted to the main boom nose (removable) for single line work. Removable pin-type rope guards.

*18 in. (457 mm) tread diameter sheaves available for main boom nose, auxiliary boom nose, and 32 ft. (9.7 m) "Swingaway" to satisfy certain international requirements.

BOOM ELEVATION – Double-acting, 12 in. (305 mm) bore hydraulic cylinders with integral holding valves. Elevation from –4° to 80°. Combination controls for hand or foot operation.

LOAD MOMENT AND ANTI-TWO BLOCK SYSTEM (KRUGER) – Audio-visual warning in combination with Grove control lever-lockout of: hoist up, telescope out and boom down functions.

***JIBS** – 14 ft. (4.3 m) lattice base section combines with the standard 32 ft. (9.7 m) "Swingaway" boom section to make basic 46 ft. (14.0 m) jib. Additional 14 ft. (4.3 m) pinned inserts available to make 60 ft. (18.3 m), 74 ft. (22.6 m) and 88 ft. (26.8 m) jib lengths. Mast, pendant lines, attaching hardware and backstops included in the makeup of all jib lengths. Jib sheave mounted on tapered roller bearings. The jib is cable suspended and offset from a minimum of 5° to a maximum of 30°.

CAB – Full vision, all-steel, fully enclosed with acoustical treatment, tinted safety glass throughout; removable windshield with storage provisions, hinged tinted skylight, sliding left side door, sliding right side glass, door and

window locks; full adjustable operator's seat with headrest, hot water heater, electric windshield wiper and defroster fan, swing horn, dome light, dashlight; complete engine instrumentation and crane operating controls, outrigger control panel, adjustable full length control levers, combination hand/foot controls for swing, boom elevation and engine throttle, sight leveling bubble, electronic boom angle indicator with high/low angle pre-sets and audio-visual warning, 3¼ lbs. (1.7 kg) dry type fire extinguisher. (Air conditioning available)

CAB INSTRUMENTATION – Engine oil pressure gauge, engine water temperature gauge, voltmeter, tachometer, fuel level gauge, ignition-on indicator light, hydraulic oil by-pass indicator light.

SWING – Roller bearing swing circle, 360° continuous rotation. Grove planetary "glide swing" with foot actuated disc swing brake, hand operated turntable brake and 360° position positive turntable lock. Combination controls provided for hand or foot operation. Swing speed 1.8 RPM.

OUTRIGGER CONTROLS – Independently controlled in-out-up and down, from superstructure cab and either side of carrier frame. Sequence control design eliminates accidental outrigger actuation.

COUNTERWEIGHT 12,975 lbs. (5885 kg) turntable mounted, power installed and removed, hydraulically extended to working position and retracted to stowed or travel position. (Refer to Axle Weight Distribution Chart for counterweight used with auxiliary hoist)

HYDRAULIC SYSTEM:

RESERVOIR – 305 gallons (1154 liters), all-steel welded construction with integral baffles, clean out access and exterior oil sight level.

FILTER – Suction line type, full flow with by-pass protection and filter by-pass indicator, replaceable cartridge, 25 micron rating.

PUMPS – Five section, gear-type driven by superstructure engine. Manual pump disconnect. Combined capacity 289 GPM (1094 lpm).

CONTROL VALVES – Precision four-way, double-acting with integral load check, main and circuit relief valves. Five individual valve banks permit simultaneous independent control of five crane functions. Maximum system operating pressure 2500 PSI (175 kg/cm²).

OIL COOLER – Full flow, fin and tube, oil to air.

POWER DISTRIBUTION – (Swing) (*Auxiliary hoist, inner mid telescope) (Lift) (Main hoist) (Outer mid telescope, *auxiliary hoist boost).

*Denotes optional equipment

HOIST SPECIFICATIONS

| HOIST DATA | MAIN HOIST Grove Model 32S-1726B | *AUXILIARY HOIST Grove Model 32S-1716B | *AUXILIARY HOIST Grove Model 15S-16B | *AUXILIARY HOIST CONTROLLED (FREE FALL) Gearmatic Model 11 SGECR |
|--|--|--|---|--|
| DESCRIPTION: Series-parallel circuitry and two motors provide both high line pull and speed ranges. Power up and down, equal speed, planetary reduction with integral automatic brake and electronic hoist drum rotation indicator. | | | DESCRIPTION: Power up and down, equal speed, planetary reduction with integral automatic brake and electronic hoist drum rotation indicator. | |
| Drum Dimensions | 16 in. diameter (406 mm) 26 in. length (660 mm) 24 in. dia. flange (610 mm) | 16 in. diameter (406 mm) 16 in. length (406 mm) 24 in. dia. flange (610 mm) | 12 in. diameter (305 mm) 16 in. length (406 mm) 17.5 in. dia. flange (445 mm) | 9 in. diameter (229 mm) 13 in. length (330 mm) 17.5 in. dia. flange (445 mm) |
| Performance: Max. Single Line Speed Max. Single Line Pull | Hi-Speed Range 575 FPM (175.3 m/min) Lo-Speed Range 290 FPM (88.4 m/min) | Hi-Speed Range 525 FPM (160.02 m/min) Lo-Speed Range 265 FPM (80.77 m/min) | 206 FPM (62.8 m/min) 9,165 lbs. (4157 kg) | 290 FPM (88.39 m/min) 9,145 lbs. (4148 kg) |
| Drum Rope Storage Capacity | †1060 ft. of ¾ in. dia. rope max. (323.0 m of 19 mm) | †650 ft. of ¾ in. dia. rope max. (198.1 m of 19 mm) | 480 ft. of ¾ in. dia. rope (146.3 m of 16 mm) 720 ft. of ½ in. dia. rope (219.5 m of 13 mm) | 675 ft. of ½ in. dia. rope (205.7 m of 13 mm) |
| Permissible Single Line Rope Pull | ¾ in. (19 mm) 8x25 class - 14,605 lbs. (6625 kg) ¾ in. (19 mm) 19x7 class - 13,700 lbs. (6214 kg) | ¾ in. (19 mm) 8x25 class - 13,145 lbs. (5963 kg) ¾ in. (19 mm) 19x7 class - 13,145 lbs. (5963 kg) | ¾ in. (16 mm) 6x41 class - 7,926 lbs. (3595 kg) ¾ in. (16 mm) 19x7 class - 7,926 lbs. (3595 kg) | ½ in. (13 mm) 6x37 class - 7,600 lbs. (3447 kg) ½ in. (13 mm) 19x7 class - 6,150 lbs. (2790 kg) |

*Denotes Optional Equipment

†6th layer of rope not recommended for hoisting operations

(5th layer for Model 15 hoist with ¾" rope)

SUPERSTRUCTURE ENGINE SPECIFICATIONS

| MAKE & MODEL | Cummins V555-C230 | *GM6V-53N | *Caterpillar 3208 |
|--------------------------|--|---|--|
| TYPE | 8 Cylinder O.H.V. | 6 Cylinder O.H.V. | 8 Cylinder O.H.V. |
| BORE & STROKE | 4.625 in. x 4.125 in. (117 mm x 105 mm) | 3.875 in. x 4.5 in. (98 mm x 114 mm) | 4.5 in. x 5.0 in. (114 mm x 127 mm) |
| DISPLACEMENT | 555 cu. in. (9096 cm ³) | 318 cu. in. (5212 cm ³) | 636 cu. in. (10 424 cm ³) |
| HORSEPOWER (NET) | 199 @ 3000 RPM | 196 @ 2800 RPM | 199 @ 2800 RPM |
| GOVERNED RPM | 3000 | 2800 | 2800 |
| TORQUE (NET) | 394 lbs. ft. @ 1800 RPM | 427 lbs. ft. @ 1500 RPM | 450 lbs. ft. @ 1400 RPM |
| ELECTRICAL SYSTEM | 12 volt neg. ground | 12 volt neg. ground | 12 volt neg. ground |
| COMBUSTION SYSTEM | 4 cycle naturally aspirated | 2 cycle with blower | 4 cycle naturally aspirated |
| COOLING SYSTEM | Liquid | Liquid | Liquid |
| FUEL CAPACITY | 78 Gallons (295 liters) | 78 Gallons (295 liters) | 78 Gallons (295 liters) |
| ALTERNATOR | 58 Amp 12 volt | 62 Amp 12 volt | 55 Amp 12 volt |
| BATTERY | (2) 204 A.H. 12 volt | (2) 204 A.H. 12 volt | (2) 204 A.H. 12 volt |
| AIR CLEANER | Dry Type | Dry Type | Dry Type |
| HOURLY METER | Yes 10,000 hr. | Yes 10,000 hr. | Yes 10,000 hr. |
| STARTING SYSTEM | 12 volt | 12 volt | 12 volt |

NOTE: With air conditioning, engine horsepower and performance will be slightly reduced. *Denotes Optional Engines



CARRIER SPECIFICATIONS

MODEL 8480G - 8 x 4 DRIVE

OUTRIGGERS - Hydraulic double box 2-stage telescoping beam outriggers, integral welded boxes, removable beams, vertical jack cylinders with integral holding valves and 30½ in. (775 mm) diameter steel floats. Beams extend to 25 ft. 5¼ in. (7.75 m) centerline to centerline retract to 9 ft. 10 in. (3.00 m) overall width. Mechanical spin locks on each vertical jack to secure outriggers at any level. Controls and sight leveling bubble located in superstructure cab and each side of carrier frame. Powered by superstructure engine.

***FRONT END STABILIZER** - A fifth hydraulic vertical outrigger jack cylinder with integral holding valve is mounted to the front frame section of the chassis to permit 360° lifting capabilities. Steel float easily removed for highway travel. Individual controls for fifth outrigger cylinder conveniently located in superstructure cab and each side of carrier frame.

FRAME - High strength steel, all welded construction. Box type design with integral outrigger boxes.

STEERING GEAR - Ross TE-72740 Cam and lever type with Garrison hydraulic power assist.

CLUTCH - Lipe Rollway 14 in. (356 mm) two plate dry disc.

TRANSMISSION - Fuller Roadranger (RTO09513) 13 speeds forward and 2 reverse.

UNIVERSAL JOINTS - Needle bearing type.

AXLES - Front: (2) Shuler tubular steering DCB34-L-7 100 in. (2.54 m) track, 44,000 lbs. (19 958 kg) capacity.

Rear: (2) Clark BD-57000 planetary drive, 90 in. (2.29 m) track, 85,000 lb. (38 556 kg) capacity.

SUSPENSION - Front: Reyco 21B spring mounted tandem, 44,000 lb. (19 958 kg) capacity.

Rear: Hendrickson solid mount tandem with equalizing beam and solid steel saddles, 85,000 lb. (38 556 kg) capacity.

FUEL TANK - Single 100 gallons (379 liters) capacity mounted on right side of frame.

TIRES - 14-00 x 20 22 PR G-20XZA4 Michelin radial tube-type, Hi-way tread front and rear.

WHEELS - Steel spoke 10 in. x 20 in. (254 mm x 508 mm)

BRAKES - Full air on all wheels.

Front: 15 in. x 6 in. (381 mm x 152 mm)

Rear: 16½ in. x 7 in. (419 mm x 178 mm). Total lining area: 1,672 in.² (10 788 cm²). Air dryer provided to preclude system-damaging moisture accumulation.

PARKING BRAKE - Maxi-type, spring set emergency chambers on both rear axles with emergency release kit.

ELECTRICAL SYSTEM - 12 volt lighting, 24 volt starting. Federal safety standard lights and reflectors.

CAB - One man, all steel, with acoustical treatment, tinted safety glass windshield and windows; windshield washer and electric wiper, door and window locks, Bostrom "T" bar seat, seat belt, dual West Coast Mirrors, dome light, dash light, hot water heater, defroster fan, electric horn, traffic hazard warning switch (four-way flasher), full engine instruments and carrier controls, 2½ lb. (1.7 kg) dry type fire extinguisher. (Air conditioning available).

CAB INSTRUMENTATION - Engine oil pressure gauge, speedometer, air pressure gauge, fuel level gauge, engine water temperature gauge, voltmeter, tachometer, low air pressure audio-visual warning device, high beam indicator, ignition-on indicator.

MISCELLANEOUS STANDARD EQUIPMENT - Wheel nut wrench and handle, channel type front bumper, two front and rear towing loops, front and rear fenders, ether injection starting aid (less canister) front deck storage trough, mud flaps.

SPEED AND GRADEABILITY

| Engine | Speed Ranges @ Max. Governed RPM | % of Gradeability @ Max. Torque |
|--------------------|----------------------------------|---------------------------------|
| Cummins NTC350 | 2.33 to 45.51 MPH (4 to 73 km/h) | 40.58 to .66% |
| GM8V-71N | 2.33 to 45.51 MPH (4 to 73 km/h) | 35.33 to .39% |
| *Caterpillar 3406T | 2.33 to 45.51 MPH (4 to 73 km/h) | 43.75 to .82% |

NOTE: Performance based on 119,000 lb. (53 978 kg) GVW and standard SAE engine rating conditions using standard tires, transmissions and axles. Performance data may vary plus or minus 10% due to variations in engine performance and vehicle weights.

*Denotes optional equipment

CARRIER ENGINE SPECIFICATIONS

| MAKE & MODEL TYPE | Cummins NTC350 6 Cylinder O.H.V. | *GM8V-71N 8 Cylinder O.H.V. | *Caterpillar 3406T 6 Cylinder O.H.V. |
|-------------------------------|--|--|--|
| BORE & STROKE | 5.5 in. x 6 in. (140 mm x 152 mm) | 4.25 in. x 5 in. (108 mm x 127 mm) | 5.4 in. x 6.5 in. (137 mm x 165 mm) |
| DISPLACEMENT | 855 cu. in. (14 013 cm ³) | 568 cu. in. (9310 cm ³) | 893 cu. in. (14 636 cm ³) |
| HORSEPOWER (NET) GOVERNED RPM | 304 @ 2100 RPM 2100 | 268 @ 2100 RPM 2100 | 287 @ 2100 RPM 2100 |
| TORQUE (NET) | 914 lbs. ft. (126 kg m) @ 1500 RPM | 733 lbs. ft. (101 kg m) @ 1600 RPM | 901 lbs. ft. (125 kg m) @ 1200 RPM |
| ELECTRICAL SYSTEM | 12 Volt Neg. Ground | 12 Volt Neg. Ground | 12 Volt Neg. Ground |
| COMBUSTION SYSTEM | 4 Cycle turbocharged | 2 Cycle w/blower | 4 Cycle turbocharged |
| COOLING SYSTEM | Liquid | Liquid | Liquid |
| FUEL CAPACITY | 100 Gallons (379 liters) | 100 Gallons (379 liters) | 100 Gallons (379 liters) |
| ALTERNATOR | 90 Amp 12 Volt | 90 Amp 12 Volt | 90 Amp 12 Volt |
| BATTERY | ●(4) 12 volt 475 CCA | ●(4) 12 volt 475 CCA | ●(4) 12 volt 475 CCA |
| AIR CLEANER | Dry Type | Dry Type | Dry Type |
| AIR COMPRESSOR | 13.2 CFM | 12 CFM | 12 CFM |
| HOURLY METER | Yes | Yes | Yes |
| STARTING SYSTEM | 24 Volt | 24 Volt | 24 Volt |

Note: (1) Engine brake (GM & Cummins engines) or driveline retarder (Caterpillar engine) are optional.

(2) With air conditioning, engine horsepower and performance will be slightly reduced.

● CCA = Cold Cranking Amperage

DIMENSIONS

TURNING RADIUS - 42 ft. 2½ in. (12 865)
GROUND CLEARANCE - 12 in. (with float removed) (305)
TAIL SWING - 12 ft. ½ in. (counterweight in travel position) (3670)
TAIL SWING - 14 ft. ½ in. (counterweight in working position) (4280)
NOTE: Dimensions shown in parentheses are millimeters (mm)

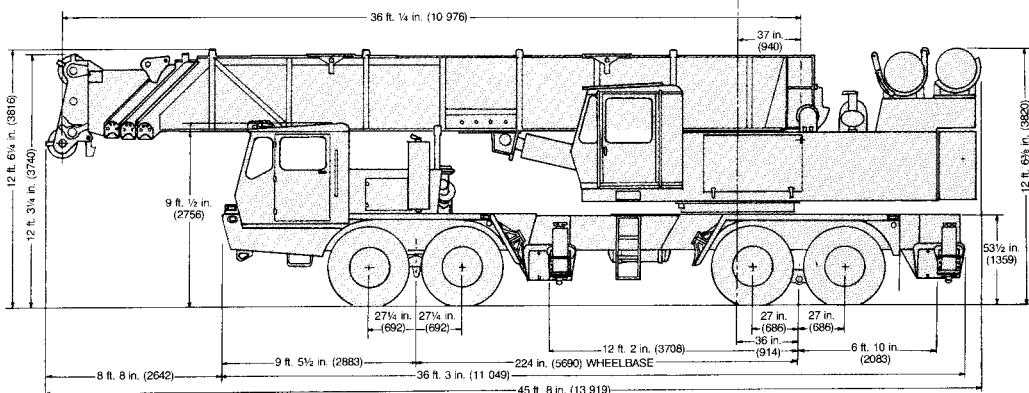
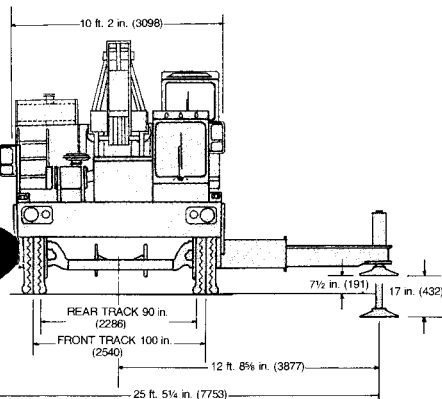



CARRIER SPECIFICATIONS

MODEL 126100G - 12 x 6 DRIVE

OUTRIGGERS - Hydraulic double box 2-stage telescoping beam outriggers, integral welded boxes, removable beams, vertical jack cylinders with integral holding valves and 30½ in. (775 mm) diameter steel floats. Beams extend to 25 ft. 5¼ in. (7.75 m) centerline to centerline retract to 9 ft. 10 in. (3.00 m) overall width. Mechanical spin locks on each vertical jack to secure outriggers at any level. Controls and sight leveling bubble located in superstructure cab and each side of carrier frame. Powered by superstructure engine.

***FRONT END STABILIZER** - A fifth hydraulic vertical outrigger jack cylinder with integral holding valve is mounted to the front frame section of the chassis to permit 360° lifting capabilities. Steel float easily removed for highway travel. Individual controls for fifth outrigger cylinder conveniently located in superstructure cab and each side of carrier frame.

FRAME - High strength steel, all welded construction. Box type design with integral outrigger boxes.

STEERING GEAR - Ross TE-72740 Cam and lever type with Garrison hydraulic power assist.

CLUTCH - Lipe Rollway 15½ in. (394 mm), two plate dry disc.

TRANSMISSION - Fuller Roadranger (RTOO9513) 13 speeds forward and 2 reverse.

UNIVERSAL JOINTS - Needle bearing type.

AXLES - Front: (3) Shuler tubular steering DCB34-L-7 100 in. (2.54 m) track, 66,000 lbs. (29 938 kg) capacity.
Rear: (3) Clark BD50-60 planetary drive, 85 in. (2.16 m) track, 108,000 lb. (48 989 kg) capacity.

SUSPENSION - Front: Reyco 21B spring mounted tridem, 66,000 lb. (29 938 kg) capacity.
Rear: Hendrickson Tri-axle equalizing beam with solid steel saddles, 108,000 lb. (48 989 kg) capacity.

FUEL TANK - Single 100 gallons (379 liters) capacity mounted on right side of frame.

TIRES - 14:00 x 20 22 PR G-20XZA4 Michelin radial tube-type, Hi-way tread front and rear.

WHEELS - Steel spoke 10 in. x 20 in. (254 mm x 508 mm)

BRAKES - Full air on all wheels.
Front: 15 in. x 6 in. (381 mm x 152 mm)
Rear: 16½ in. x 7 in. (419 mm x 178 mm). Total lining area: 2508 in.² (16 182 cm²).

PARKING BRAKE - Maxi-type, spring set emergency chambers on all rear axles with emergency release kit.

ELECTRICAL SYSTEM - 12 volt lighting, 24 volt starting. Federal safety standard lights and reflectors.

CAB - Two-man, low profile design, all steel with acoustical treatment, laminated safety glass windshield and windows throughout; windshield washer and electric wiper, door and window locks. Bostrom "T" bar drivers seat and Bostrom companion seat, seat belts, heater, defroster fan, dual West Coast mirrors, domelight, dashlight, electric horn, traffic hazard warning switch (4-way flasher), complete instrumentation and driving controls, sliding right side and roll-down left side glass for ventilation, 2¼ lb. (1.7 kg) dry type fire extinguisher. (Air conditioning available).

CAB INSTRUMENTATION - Engine oil pressure gauge, speedometer, air pressure gauge, fuel level gauge, engine water temperature gauge, voltmeter, tachometer, low air pressure audio-visual warning device, high beam indicator, ignition-on indicator.

MISCELLANEOUS STANDARD EQUIPMENT - Wheel nut wrench and handle, channel type front bumper, two front and rear towing loops, front and rear fenders, ether injection starting aid (less canister), front deck hookblock storage trough, mud flaps, tool storage compartment, counterweight storage brackets mounted on carrier.

SPEED AND GRADEABILITY

| Engine | Speed Ranges @ Max. Governed RPM | % of Gradeability @ Max. Torque |
|--------------------|----------------------------------|---------------------------------|
| Cummins NTC350 | 2.35 to 45.84 MPH (2 to 74 km/h) | 36.70 to .43% |
| *GM8V-71T | 2.35 to 45.84 MPH (4 to 74 km/h) | 35.26 to .38% |
| *Caterpillar 3406T | 2.35 to 45.84 MPH (4 to 74 km/h) | 36.59 to .45% |

NOTE: Performance based on 130,000 lb. (58 968 kg) GVW and standard SAE engine rating conditions using standard tires, transmissions and axles. Performance data may vary plus or minus 10% due to variations in engine performance and vehicle weights.

*Denotes Optional Equipment

CARRIER ENGINE SPECIFICATIONS

| MAKE & MODEL TYPE | Cummins NTC350 6 Cylinder O.H.V. 5.5 in. x 6 in. (140 mm x 152 mm) | *GM8V-71T 8 Cylinder O.H.V. 4.25 in. x 5 in. (108 mm x 127 mm) | *Caterpillar 3406TA 6 Cylinder O.H.V. 5.4 in. x 6.5 in. (137 mm x 165 mm) |
|-------------------------------|---|---|--|
| BORE & STROKE | 5.5 in. x 6 in. (140 mm x 152 mm) | 4.25 in. x 5 in. (108 mm x 127 mm) | 5.4 in. x 6.5 in. (137 mm x 165 mm) |
| DISPLACEMENT | 855 cu. in. (14 013 cm ³) | 568 cu. in. (9310 cm ³) | 893 cu. in. (14 636 cm ³) |
| HORSEPOWER (NET) GOVERNED RPM | 304 @ 2100 RPM | 312 @ 2100 RPM | 285 @ 2100 RPM |
| TORQUE (NET) | 2100 914 lbs. ft. (126 kg m) @ 1500 RPM | 2100 876 lbs. ft. (121 kg m) @ 1600 RPM | 2100 901 lbs. ft. (125 kg m) @ 1200 RPM |
| ELECTRICAL SYSTEM | 12 Volt Neg. Ground | 12 Volt Neg. Ground | 12 Volt Neg. Ground |
| COMBUSTION SYSTEM | 4 Cycle turbocharged | 2 Cycle turbocharged | 4 Cycle turbocharged |
| COOLING SYSTEM | Liquid | Liquid | Liquid |
| FUEL CAPACITY | 100 Gallons (379 liters) | 100 Gallons (379 liters) | 100 Gallons (379 liters) |
| ALTERNATOR | 53 Amp 12 Volt | 75 Amp 12 Volt | 65 Amp 12 Volt |
| BATTERY | (2) 204 A.H. 12 Volt | (2) 204 A.H. 12 Volt | (2) 204 A.H. 12 Volt |
| AIR CLEANER | Dry Type | Dry Type | Dry Type |
| AIR COMPRESSOR | 15 CFM | 12 CFM | 12 CFM |
| HOURMETER | Yes | Yes | Yes |
| STARTING SYSTEM | 24 Volt | 24 Volt | 24 Volt |

Note: (1) GM and Cummins engines equipped with Jacobs engine brake. Units with Caterpillar engine equipped with brakesaver.

(2) With air conditioning, engine horsepower and performance will be slightly reduced.

DIMENSIONS

TURNING RADIUS - 51 ft. (15 545)
GROUND CLEARANCE - 10¼ in. (with float removed) (260)
TAIL SWING - 12 ft. ½ in. (counterweight in travel position) (3670)
TAIL SWING - 14 ft. ½ in. (counterweight in working position) (4280)
NOTE: Dimensions shown in parentheses are millimeters (mm)

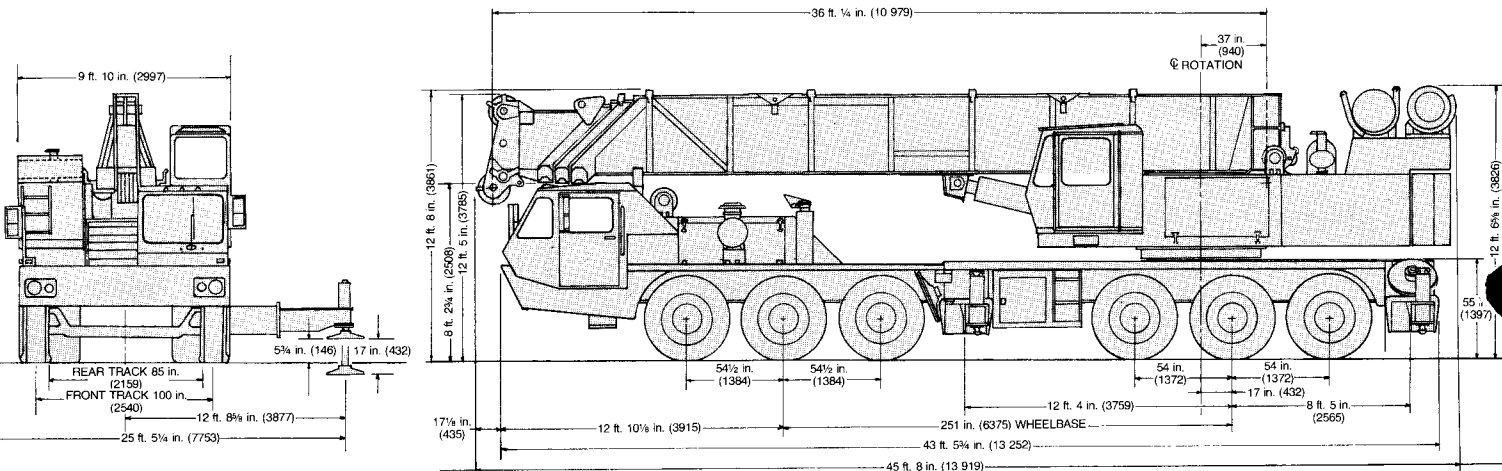



8x4 CARRIER

AXLE WEIGHT DISTRIBUTION CHART

| ITEM | POUNDS | | | KILOGRAMS | | |
|--|---------|--------|---------|-----------|--------|--------|
| | GROSS | FRONT | REAR | GROSS | FRONT | REAR |
| Basic standard machine to include 36 – 114 ft. (10.9 – 34.8 m) trapezoidal boom (power pinned fly) plus a 32 ft. (9.7 m) "Swingaway" extension, Grove Model 32S-1726B main hoist with 750 ft. (228.6 m) of ¾ in. (19 mm) rope, 12,975 lb. (5885 kg) counterweight, Grove Model 8 x 4-80 carrier, Cummins NTC 350 (carrier engine), Cummins V555-C230 (superstructure engine) | 119,089 | 40,612 | 78,477 | 54 019 | 18 421 | 35 597 |
| REMOVE: | | | | | | |
| •Standard 12,975 lb. (5885 kg) counterweight | -12,975 | +5,288 | -18,263 | -5885 | +2399 | -8284 |
| Standard 32 ft. (9.7 m) "Swingaway" extension | -1,654 | -1,685 | +31 | -750 | -764 | +14 |
| Standard main hoist with rope | -2,825 | +776 | -3,601 | -1281 | +352 | -1633 |
| (2) front outrigger beams & jacks | -5,000 | -3,259 | -1,741 | -2268 | -1478 | -790 |
| (2) rear outrigger beams & jacks | -5,000 | +2,098 | -7,098 | -2268 | +952 | -3220 |
| ADD: | | | | | | |
| 80-ton (72.5 mt), 6-sheave hookblock (stowed) | +1,600 | +2,571 | -971 | +726 | +1166 | -440 |
| Auxiliary boom head | +230 | +455 | -225 | +104 | +206 | -102 |
| Fifth front outrigger jack | +600 | +805 | -205 | +272 | +365 | -93 |
| ••Model 15S-16B auxiliary hoist with 550 ft. (167.6 m) of ¾ in. (16 mm) dia. rope | +1,119 | -460 | +1,579 | +508 | -209 | +716 |
| ••Model 11 SGEGR freefall auxiliary hoist with 550 ft. (167.6 m) of ½ in. (13 mm) dia. rope | +1,078 | -443 | +1,521 | +489 | -201 | +690 |
| •••Model 32S-1716B auxiliary hoist with 550 ft. (167.6 m) of ¾ in. (19 mm) dia. rope and idler | +2,385 | -980 | +3,365 | +1082 | -445 | +1526 |
| SUBSTITUTE: | | | | | | |
| 36-114 ft. (10.9-34.7 m) full power boom | +1,184 | +506 | +678 | +537 | +230 | +307 |
| ••12,300 lb. (5579 kg) counterweight | -675 | +275 | -950 | -306 | +125 | -431 |
| •••11,300 lb. (5126 kg) counterweight | -1,675 | +683 | -2,358 | -760 | +310 | -1070 |
| GM8V – 71N engine (carrier) | -550 | -617 | +67 | -249 | -280 | +30 |
| Caterpillar 3406T engine (carrier) | -165 | -185 | +20 | +75 | +84 | -9 |
| GM6V – 53N engine (superstructure) | -170 | -9 | -161 | -77 | -4 | -73 |
| Caterpillar 3208 engine (superstructure) | -410 | -22 | -388 | -186 | -10 | -176 |

- Use 12,975 lb. (5885 kg) counterweight without auxiliary hoist.
- Use 12,300 lb. (5579 kg) counterweight with Grove 15S-16B or Gearmatic Model 11 SGEGR freefall auxiliary hoist.
- Use 11,300 lb. (5126 kg) counterweight with Grove 32S-1716B auxiliary hoist.

12x6 CARRIER

AXLE WEIGHT DISTRIBUTION CHART

| ITEM | POUNDS | | | KILOGRAMS | | |
|--|---------|--------|---------|-----------|--------|--------|
| | GROSS | FRONT | REAR | GROSS | FRONT | REAR |
| Basic standard machine to include 36 – 114 ft. (10.9 – 34.8 m) trapezoidal boom (power pinned fly) plus a 32 ft. (9.7 m) "Swingaway" extension, Grove Model 32S-1726B main hoist with 750 ft. (228.6 m) of ¾ in. (19 mm) rope, 12,975 lb. (5885 kg) counterweight, Grove Model 12 x 6 – 100 carrier, Cummins NTC 350 (carrier engine), Cummins V555-C230 (superstructure engine) | 131,940 | 38,027 | 93,913 | 59 848 | 17 249 | 42 599 |
| REMOVE: | | | | | | |
| •Standard 12,975 lb. (5885 kg) counterweight | -12,975 | +5,702 | -18,677 | -5886 | +2586 | -8472 |
| Standard 32 ft. (9.7 m) "Swingaway" extension | -1,654 | -1,385 | -269 | -750 | -628 | -122 |
| Standard main hoist with rope | -2,845 | +912 | -3,757 | -1290 | +414 | -1704 |
| (2) front outrigger beams & jacks | -5,600 | -3,302 | -2,298 | -2540 | -1498 | -1042 |
| (2) rear outrigger beams & jacks | -5,600 | +2,253 | -7,853 | -2540 | +1022 | -3562 |
| ADD: | | | | | | |
| 80-ton (72.5 mt), 6-sheave hookblock (stowed) | +1,600 | +2,756 | -1,156 | +726 | +1250 | -524 |
| Auxiliary boom head | +230 | +389 | -159 | +104 | +176 | -72 |
| Fifth front outrigger jack | +600 | +809 | -209 | +272 | +367 | -95 |
| ••Model 15S-16B auxiliary hoist with 550 ft. (167.6 m) of ¾ in. (16 mm) dia. rope | +1,119 | -495 | +1,614 | +508 | -225 | +732 |
| ••Model 11 SGEGR freefall auxiliary hoist with 550 ft. (167.6 m) of ½ in. (13 mm) dia. rope | +1,078 | -477 | +1,555 | +489 | -216 | +705 |
| •••Model 32S-1716B auxiliary hoist with 550 ft. (167.6 m) of ¾ in. (19 mm) dia. rope and idler | +2,385 | -1,055 | +3,440 | +1082 | -479 | +1560 |
| SUBSTITUTE: | | | | | | |
| 36-114 ft. (10.9 – 34.7 m) full power boom | +1,184 | +351 | +833 | +537 | +159 | +378 |
| ••12,300 lb. (5579 kg) counterweight | -675 | +297 | -972 | -306 | +135 | -441 |
| •••11,300 lb. (5126 kg) counterweight | -1,675 | +736 | -2,411 | -760 | +334 | -1094 |
| GM8V-71T engine (carrier) | -400 | -447 | +47 | -181 | -203 | +21 |
| Caterpillar 3406TA engine (carrier) | -95 | -106 | +11 | -43 | -48 | +5 |
| GM6V – 53N engine (superstructure) | -170 | +5 | -175 | -77 | +2 | -79 |
| Caterpillar 3208 engine (superstructure) | -410 | +12 | -422 | -186 | +5 | -191 |

- Use 12,975 lb. (5885 kg) counterweight without auxiliary hoist.
- Use 12,300 lb. (5579 kg) counterweight with Grove 15S-16B or Gearmatic model 11 SGEGR freefall auxiliary hoist.
- Use 11,300 lb. (5126 kg) counterweight with Grove 32S-1716B auxiliary hoist.

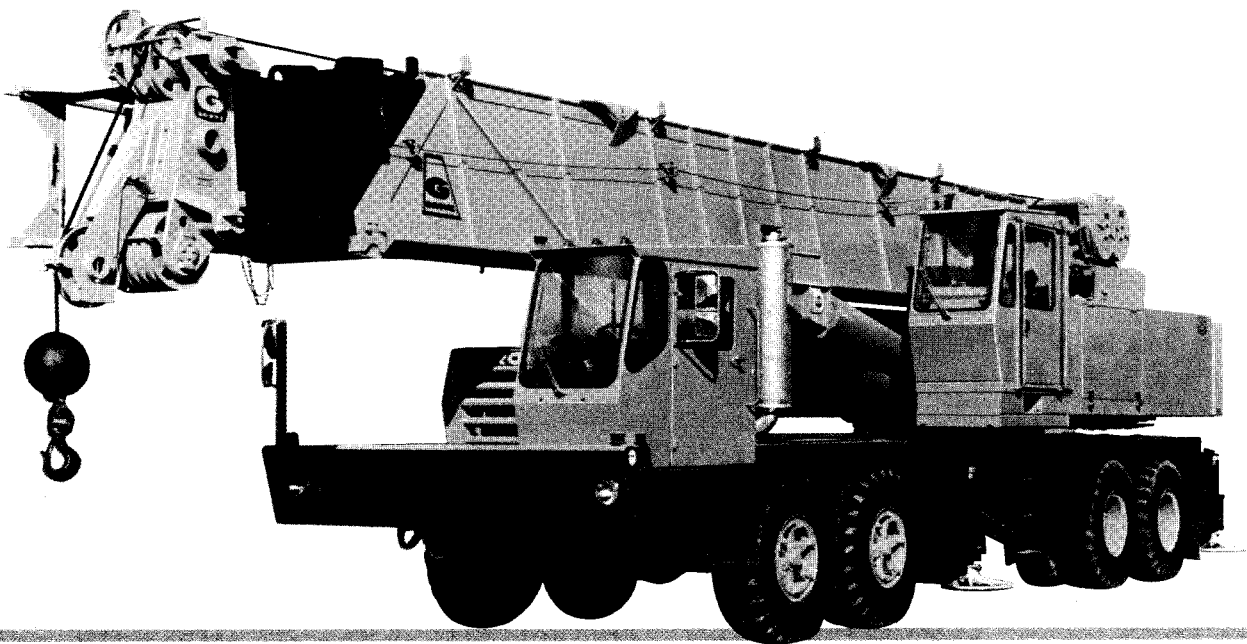

GROVE CARRIERS

The TM875 is available on a 4-axle or 6-axle carrier, both of which are designed and built by Grove to match the particular requirements of this outstanding 80-ton crane (72.5-ton metric). The all-welded, high strength steel frame is of box-type design with integral outrigger boxes. The rigid frame in combination with the 25' 5¼" (7.8 m) outrigger spread provides an exceptionally stable lifting base. The 12x6 carrier is equipped with a two-man cab.



GROVE MANUFACTURING COMPANY

Division of Walter Kidde & Company, Inc.

KIDDE

SHADY GROVE, PA. 17256 U.S.A.

Telex: 842308/Cable: GROVEMFG

WORLD LEADER IN HYDRAULIC CRANES