

| Technical Data  | HIAB 095-1   | HIAB 095-2  | HIAB 095-3   | HIAB 095-4   |
|---|--|---|--|--|
| Lifting capacity, max.  | 94.6 kNm (9.6 tm)  | 91.8 kNm (9.3 tm)   | 88.9 kNm (9.1 tm)  | 85.3 kNm (8.7 tm)  |
| Hydraulic outreach, standard                                    | 5.3 m  | 7.2 m   | 9.1 m  | 10.9 m   |
| Outreach/lifting capacity, standard                             | 2.1 m/ 4 440 kg<br>3.2 m/ 2 950 kg<br>3.5 m/ 2 800 kg<br>5.2 m/ 1 860 kg | 2.1 m/ 4 300 kg<br>3.3 m/ 2 750 kg<br>3.6 m/ 2 570 kg<br>5.3 m/ 1 740 kg<br>7.0 m/ 1 300 kg | 2.1 m/ 4 200 kg<br>3.1 m/ 2 700 kg<br>3.7 m/ 2 430 kg<br>5.4 m/ 1 620 kg<br>7.1 m/ 1 190 kg<br>9.0 m/ 930 kg | 2.0 m/ 4 170 kg<br>3.5 m/ 2 410 kg<br>3.8 m/ 2 300 kg<br>5.3 m/ 1 540 kg<br>7.0 m/ 1 120 kg<br>8.8 m/ 850 kg<br>10.7 m/ 640 kg |
| Outreach/lifting capacity, with manual boom extensions          | 6.8 m/ 1 370 kg<br>8.7 m/ 1 020 kg                                       | 8.9 m/ 960 kg<br>11.0 m/ 750 kg   | 10.8 m/ 730 kg   | 12.7 m/ 550 kg   |
| Lifting height at 1.0 m from crane column centre                | 2.69 m   | 2.53 m  | 2.38 m   | 2.27 m   |
| Rec. oil flow   | 40 l/min   | 40 l/min  | 40 l/min   | 40 l/min   |
| Slewing angle   | 400°   | 400°  | 400°   | 400°   |
| Height in folded position                                       | 2.125 m  | 2.125 m   | 2.125 m  | 2.125 m  |
| Width in folded position  | 2.485 m  | 2.485 m   | 2.485 m  | 2.485 m  |
| Weight – standard version with 3.6 m outrigger and support legs | 1 205 kg   | 1 315 kg  | 1 415 kg   | 1 505 kg   |

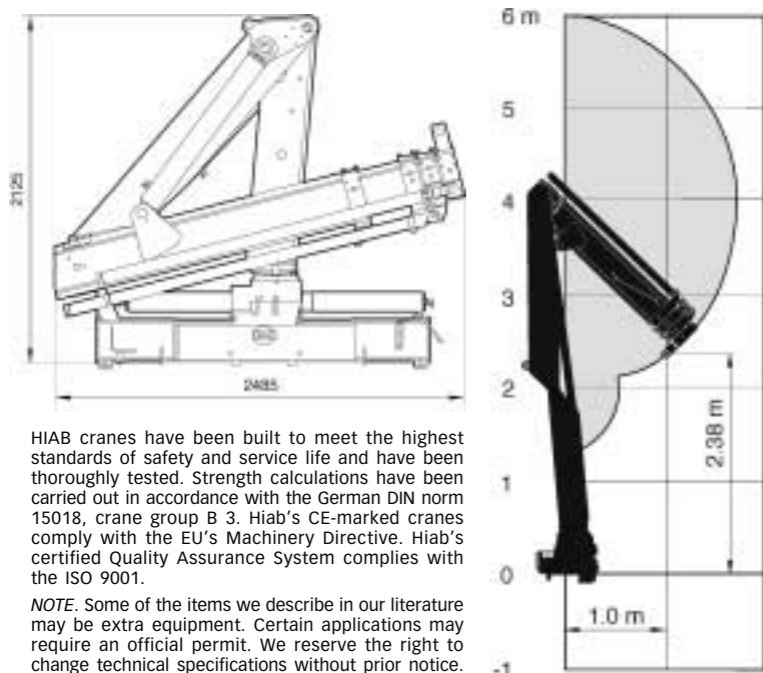

# HIAB 095



HIAB cranes have been built to meet the highest standards of safety and service life and have been thoroughly tested. Strength calculations have been carried out in accordance with the German DIN norm 15018, crane group B 3. Hiab's CE-marked cranes comply with the EU's Machinery Directive. Hiab's certified Quality Assurance System complies with the ISO 9001.

NOTE: Some of the items we describe in our literature may be extra equipment. Certain applications may require an official permit. We reserve the right to change technical specifications without prior notice.

### HIAB 095-3

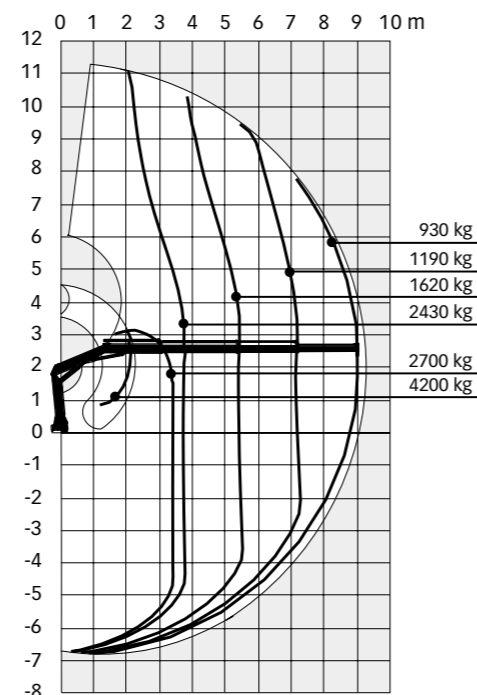

For more information about the HIAB 095, or any other Hiab crane, please contact your local Hiab distributor.

1283 GB 10.02 Printed in Finland by Waasa Graphics Oy

# Look at HIAB 095 – a member of the Hiab family – the world's No.1 selling knuckleboom cranes.

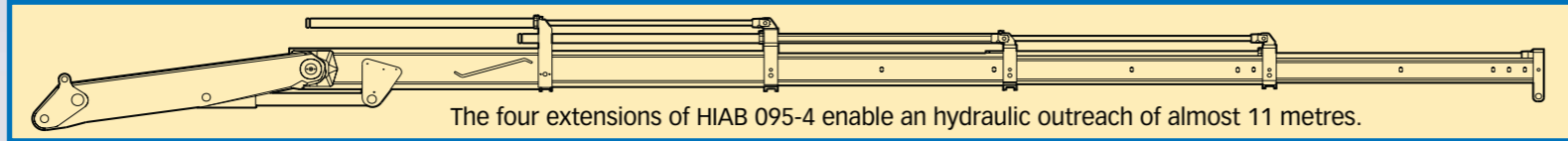

## HIAB 095 – the strong choice in the 10 tm class

The HIAB 095 is a further development of the popular HIAB 090, but it does everything better. Both cranes look very similar, but that's where the similarities cease.

The HIAB 095 features a new, low-headroom boom system with a separate extension cylinder on each extension. We have done away with all hosing on the outer boom and extensions and reduced the need for a hook attachment to just one – on the outer extension. All that leads to easier handling in confined areas. And new larger slide-pads considerably reduce friction and give smoother boom-action.

The HIAB 095's working geometry has been optimised, resulting in better lifting capacity – in the upper lifting range, capacity has been boosted by over 20%. What's more, the 095 has an amazing close-in lifting height.

The HIAB 095 is a modern general cargo crane in the 10 tm capacity class that offers excellent manoeuvrability. Choose between cross-controls, HIAB's well-known 50-valve version with the new CombiDrive 50 or the more advanced CombiDrive with HIAB Valve 91 and top-seat or control-platform.

First rate operational control and freedom. That's what the new HIAB 095 offers you. Add Hiab's MiniSPACE or SPACE safety system and you have a working partner that is reliability personified. You can further adapt this workhorse to your specific needs by choosing between a range of options, such as winches, buckets, pallet forks and more.

The HIAB 095 offers supreme ease of operation and a level of safety that is second-to none.

The original was excellent, this new model is better.



A pleasure to operate and safer – with the CombiDrive 50 remote control, or as shown here, the more advanced CombiDrive.

