

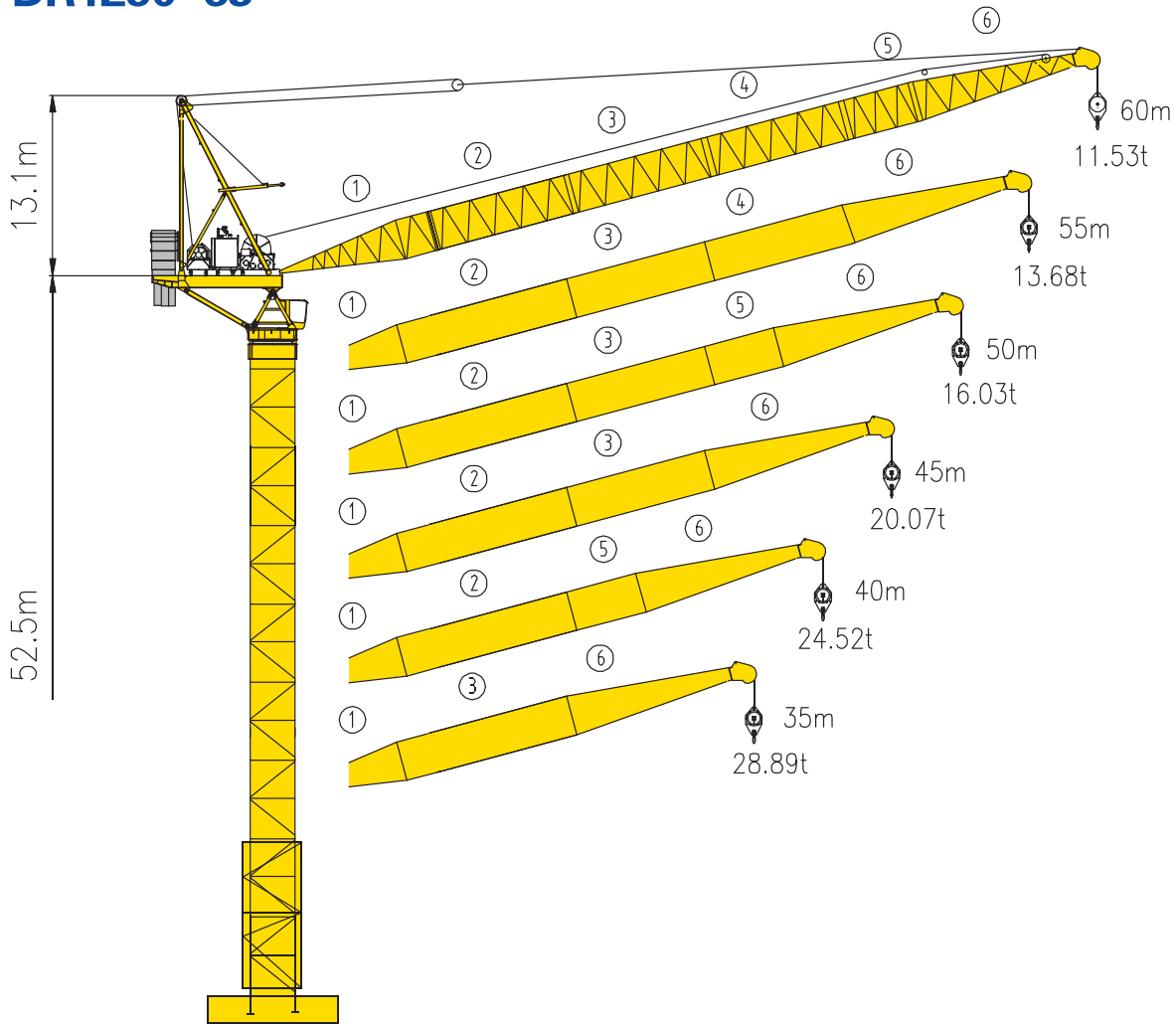

DR1250-63



Counter-jib ballast

		 (Kg)	PHZ12400	PHZ7000	PHZ2000
60m	8.9m	64200	3	3	3
55m	8.9m	62200	3	3	2
50m	8.9m	60200	3	3	1
45m	8.9m	60200	3	3	1
40m	8.9m	60200	3	3	1
35m	8.9m	58200	3	3	0

Working Height(m) @ Wall-tie Location(m)

Model Detail	Mast Code	Wall-tie #1	Wall-tie #2	Wall-tie #3	Wall-tie #4	Wall-tie #5	Wall-tie #6	Wall-tie #7	Wall-tie #8	Wall-tie #9	Wall-tie #10
DR1250-63	N1	62.85 @ 30	79.95 @ 47.5	97.05 @ 64.37	114.75 @ 81.5	131.25 @ 98.6	148.35@115.73	165.45@132.83	182.55@149.9	199.65@167	216.75@184

Masts Reactions

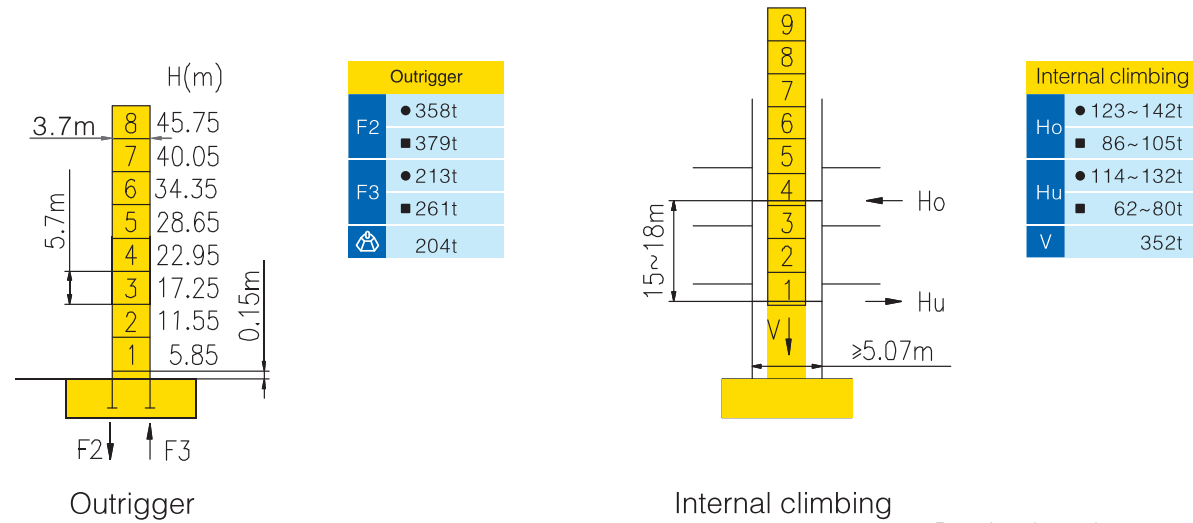





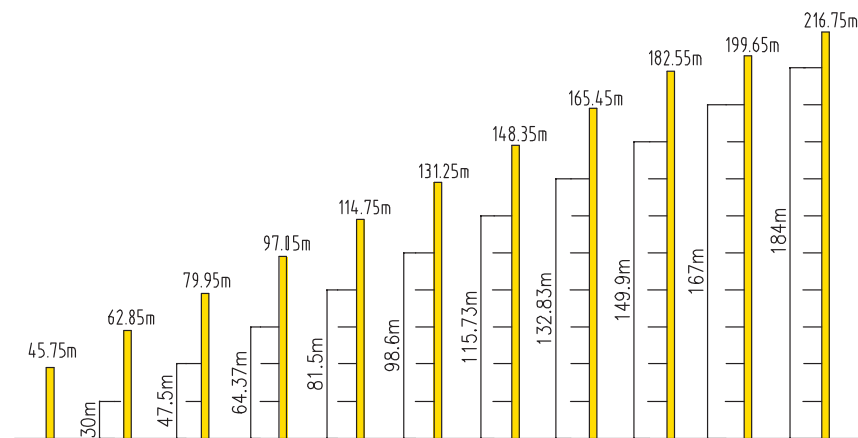







● Reactions in service ■ Reactions out of service
 ⊕ Without load and ballast with longest jib and maximum height
 ⊕ For more erecting solutions, consult us!







Anchorage

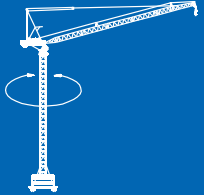
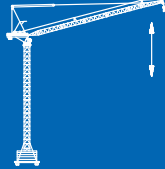

Load diagrams

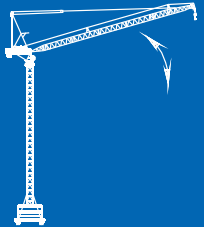
		Max.Capacity m/t	18	20	23	25	28	30	33	35	38	40	43	45	48	50	53	55	58	60	
60m (R=61.11)		7.2—25.22m 32t	32					30.14	28.8	27.1	25.49	23.07	21.54	19.37	18.10	16.39	15.38	14.02	13.23	12.16	11.53
		7.19—9.83m 43.5t	37.97	36.35	34.13	32.08	29.6	28.34	26.55	24.65	22.52	20.99	18.83	17.56	15.88	14.88	13.55	12.76	11.74	11.2 (59.8)	
55m (R=55.08)		6.73—29.27m 32t	32					31.82	28.14	26	23.24	21.76	19.41	18.30	16.67	15.66	14.43	13.68			
		6.73—9.14m 58.5t	47.27	44.42	40.03	37.75	34.45	31.31	27.60	25.54	22.73	21.13	19.04	17.82	16.19	15.24	14.01	13.37 (54.9)			
50m (R=50.08)		6.23—30.40m 32t	32					29.04	26.82	23.95	22.27	20.07	18.78	17.07	16.03						
		6.2—9.26m 63t	49.63	46.61	40.92	37.79	34.00	31.95	28.52	26.25	23.45	21.88	19.60	18.33	16.65	15.79 (49.8)					
45m (R=45.04)		5.74—31.14m 32t	32					30.27	28.05	25.18	23.51	21.34	20.07								
		5.70—13.84m 63t	56.81	51.67	44.98	41.15	36.33	33.53	29.79	27.57	24.72	23.07	20.93	19.87 (44.7)							
40m (R=40.04)		5.24—31.68m 32t	32					30.77	28.68	26.01	24.52										
		5.23—15.78m 63t	54.98	54.09	46.75	42.37	37.02	34.07	30.36	28.27	25.63	24.31 (39.8)									
35m (R=35.01)		4.74—31.60m 32t	32					30.68	28.89												
		4.71—19.81m 63t	63	62.89	52.92	46.92	39.38	35.02	30.32	28.82 (34.7)											

Mechanisms

		Hoisting				
	Slewing		I		32t	0-9 m/min
	0 ~ 0.7 r/min		II		32t	0-20 m/min
	Luffing		III		32t	0-40 m/min
	2 min (15° ~ 84.5°)		IV		14t	0-85 m/min
Diesel engine	CAT15		 780m $\text{\textcircled{I}}$ (7 layers) $\text{\textcircled{I}}$ Consult us If overtop	V		8.5t