



SCX500

HYDRAULIC CRAWLER CRANE

Specifications

ASIAN ISSUE

This catalog is not applicable to European and North America areas.
The machine shown may vary according to territory Specifications.
Specifications are subject to change without notice.

Hitachi Sumitomo Heavy Industries Construction Cranes Co.,Ltd

Head Office : 12-14 Ueno 7-chome, Taito-ku,
Tokyo 110-005, Japan

Telephone : 81-3-3845-1387

Facsimile : 81-3-3845-1394

<http://www.hands-crane.com>

Printed in Japan. 0610Ⓚ02T.EA094

HITACHI SUMITOMO

SCX500

HYDRAULIC CRAWLER CRANE



CRAWLER CRANE	■Dimensions ■Specifications	3
	■Superstructure	4
	■Working Ranges	8
	■Crane Ratings (Main Boom in 360° Working Area)	9
	■Crane Ratings (Fly Jib in 360° Working Area).....	10 to 11
	■Crane Boom Construction ■Fly Jib Construction	
	■Component Weights and Dimensions for Transport	12
FULL-LUFFING TOWER CRANE	■Dimensions ■Tower Jib Construction	
	■Specifications	13
	■Rated loads for 22m Tower Crane ■Working Ranges	14
	■Rated loads for 25m Tower Crane ■Working Ranges	15
	■Rated loads for 28m Tower Crane ■Working Ranges	16
	■Rated loads for 31m Tower Crane ■Working Ranges	17
	■Rated loads for 34m Tower Crane ■Working Ranges	18
	■Rated loads for 37m Tower Crane ■Working Ranges	19
	■Rated loads for 40m Tower Crane ■Working Ranges	20
	■Tower Boom Construction ■Tower Jib Construction	
	■Tower/Crawler Crane Construction ■Fly Jib Construction	
	■Component Weights and Dimensions for Transport	21
CLAMSHELL	■Dimensions ■Specifications	
	■Working Ranges ■Clamshell Bucket	22
DRAGLINE	■Dimensions ■Specifications	
	■Working Ranges ■Dragline Bucket	23
TECHNICAL DATA	■Standard and Optional Equipment	24 to 25

Note: • All "t" implies metric tons in this catalog.
• Specifications conform to the Safety Regulations for Cranes and Mobile Cranes in Japan.

■Dimensions

Unit: mm

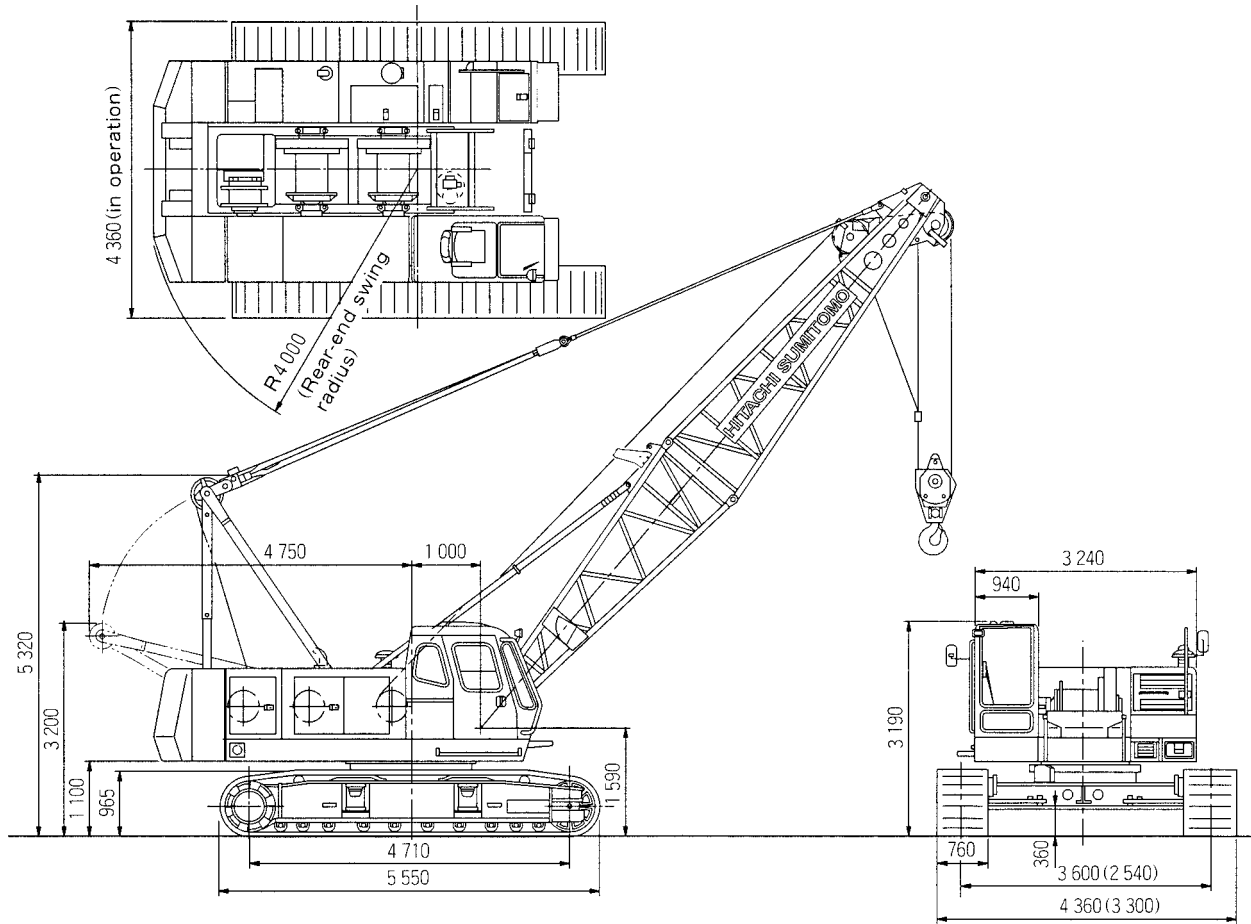

Figure in () shows dimension when side frames are retracted for trailer transport.

■Specifications

(1 t = 1 000 kg)

Maximum rated load × Working radius	t × m	50 × 3.8
Basic boom length	m	10
Maximum boom length	m	52
Winch		
Maximum line pull	t	15.6
Maximum rated line pull	t	6.5
Line speeds	Main hoist drum	m/min
	Auxiliary hoist drum	m/min
	Boom hoist drum	m/min
Swing speed	min ⁻¹ (rpm)	*110/74/37
Travel speed	km/h	*60
Gradeability	% (°)	3.7 (3.7)
Diesel Engine		2.0/1.5
Rated horsepower	kw/min ⁻¹ (PS/rpm)	40 (22)
Ground pressure	kPa (kgf/cm ²)	Isuzu 4HK1X
Operating weight	t	147/2 100 (200/2 100)
		68.6 (0.70)
		50.1
		(including 10 m boom and 50 t capacity hook)

Notes : 1. Data is expressed in SI units, followed by conventional units in ().

2. *Line speeds marked will vary with the load.



Superstructure



Engine

Model.....	Isuzu 4HK1X
Type	Water-cooled, 4-cycle, 6-cylinder, direct fuel injection type diesel engine
Rated horsepower	147 kW (200 PS) at 2 100 min ⁻¹ (2 100 rpm)
Maximum torque.....	688 N·m (70 kgf·m) at 1 500 min ⁻¹ (1 500 rpm)
Piston displacement	5.19 L
Fuel tank capacity	300 L
Electric system	DC 24 V

Notes:

1. The engine meets Stage/Tier 3 of current smoke emission regulations in Europe, America and Japan.
2. A 147 kW engine horsepower shown above is defined under a current international engine horsepower indication formula which includes necessary horsepower for engine alternator drive but excludes engine fan drive.



Main and Auxiliary Hoist Mechanism

- The SCX500 is equipped with dual hoist mechanisms, each consisting of independent main and auxiliary hoist drums driven by a hydraulic motor.
- Hoisting and lowering the load is achieved by forward/reverse rotation of the hydraulic motor.
- Power lowering is carried out with a hydraulic brake.
- Hoisting and lowering can be carried out at three speeds-fast, medium and slow-to suit job requirements.
- Each drum is fitted with a friction band-type brake. This allows free fall (rapid lowering) of the hook.
- Main and auxiliary hoist drums are each fitted with a pawl-type drum lock to positively hold the load in the air.
- The drum brake is an external contracting friction band-type using durable non-asbestos lining.
- The brake is controlled by the hydraulic servo system to reduce control force. With the hoist lever in neutral, auto braking or foot braking can be selected.



Boom Hoist Mechanism

- Independent operation separated from other functions.
- Boom hoisting/lowering is done by forward/reverse rotation of a hydraulic motor. Boom lowering is made by power lowering through a hydraulic brake.
- Both hydraulic brake and spring-set/hydraulic-released multiplate disc type brake offer positive stopping of the boom. When the boom is hoisted or lowered, brakes are automatically released.
- Boom hoist drum is fitted with a pawl-type drum lock.



Swing Mechanism

- Independent operation separated from other functions.
- Driven by the hydraulic motor through reduction gear. Swing speeds are freely controllable from zero to maximum speed with a single lever.

Swing Brake

The disc-type swing brake can be hydraulically applied by the brake switch on the swing lever.

Swing Lock

Manual mechanical-lock with a rod tip engaged in the holder of the track frame for transportation.

Swing Circle

Single-row shear-type ball bearing with heat-treated internal gear.



Revolving Frame

All welded steel construction, stress-relieved, precision-machined for rigidity and strength.

Gantry

Lowerable for transportation.

Counterweight

Total weight:	16 900 kg
Consisting of 2 sections:	One 7 250 kg
	One 9 650 kg



Boom

Tubular Chord Crane Boom

1 300 mm wide by 1 300 mm deep at connection, lattice construction using high-tensile steel tubular chords

Basic boom	Total length 10.0 m, 2-piece construction; upper section 5.0 m and lower section 5.0 m
Boom point	Offset boom point, 5 sheaves (462 mm PCD) mounted on anti-friction bearings on boom top
Boom inserts	3.0 m, 6.0 m and 9.0 m long available
Connection type	Pin-connected
Boom backstop	Dual-rail, telescopic tubular construction with spring damper
Boom hoist bridle	Serves as connection between pendants and boom hoist wire rope reeving, equipped with 6 sheaves (340 mm PCD) for 12-part boom hoist wire rope reeving

Crane Jib

550 mm wide by 480 mm deep at connection, lattice construction using high-tensile steel tubular chords

Jib length	Total length 6.0 m, 2-piece construction; upper section 3.0 m and lower section 3.0 m
Jib point	1 sheave (462 mm PCD) mounted on anti-friction bearings on jib top
Jib insert	3.0 m long available
Connection type	Pin-connected
Auxiliary jib	Optional. Attachable to the main boom top to hoist the light load quickly with a single rope.

Note : Boom insert, crane jib, or auxiliary jib can be attached to the basic boom when needed. However, both crane jib and auxiliary jib cannot be attached simultaneously to the boom.

Tubular Chord Tower Crane Boom

1 300 mm wide by 1 300 mm deep at connection, lattice construction using high-tensile steel tubular chords

Tower boom length.....	22.0 m, minimum 40.0 m, maximum
Tower inserts	1.5 m, 3.0 m, 6.0 m and 9.0 m tower inserts are in common with crane boom inserts
Connection type	Pin-connected
Tower backstop	Dual-rail, telescopic tubular construction with spring damper
Tower hoist bridle	Serves as connection between tower boom pendants and tower boom hoist wire rope reeving, equipped with 6 sheaves (340 mm PCD) for 12-part tower hoist wire rope reeving

Tower Jib

940 mm, wide by 750 mm deep at connection, lattice construction using high-tensile steel tubular chords

Jib length	16.0 m to 28.0 m
Jib inserts	3.0 m and 6.0 m long available
Connection type	Pin-connected
Tower jib hoist bridle	Serves as connection between tower jib pendants and tower jib hoist wire rope reeving, equipped with 4 sheaves (360 mm PCD × 3 & 420 mm PCD × 1) for 8-part tower jib hoist wire rope reeving.



Operator's Cab

All-weather, well-ventilated, roomy operator's cab with good visibility. The independent cab is insulated against noise and vibration.



Hydraulic System

- 3 variable displacement piston pumps allow both independent and combined operations of all functions.
- Variable displacement piston pumps control working speeds, and make effective use of engine horsepower.

	Pump-1	Pump-2
Type of pump	Variable displacement	
Pressure setting	29.4 MPa (300 kgf/cm ²)	29.4 MPa (300 kgf/cm ²)
Max. oil flow*	222 L/min	222 L/min

	Pump-3	Pump-4
Type of pump	Variable displacement	Gear
Pressure setting	23.0 MPa (235 kgf/cm ²)	4.9 MPa (50 kgf/cm ²)
Max. oil flow*	130 L/min	32 L/min

*with non-loaded condition

Main and Auxiliary Hoist Motors

Axial piston motors with counterbalance valves

Boom Hoist Motor

Axial piston motor with counterbalance valve

Swing Motor

Axial piston motors

Travel Motors

Axial piston motors with brake valve and spring-set/hydraulic-released multiplate disc brake

Relief and Brake Valves

- Each hydraulic circuit incorporates large-capacity relief valves to protect circuit from overload and shock load.
- Counterbalance valves, provided for hoist motor, compensate load lowering and prevent accidental load drop if hydraulic power is suddenly reduced.
- Brake valves (consisting of relief valve and counterbalance valve) are provided for travel circuit.

Pressure Settings

Main Circuit

● Main relief valves

Hoist (main and aux.)	29.4 MPa (300 kgf/cm ²)
Swing	23.0 MPa (235 kgf/cm ²)

● Overload relief valves

Hoist (main and aux.) circuits	31.4 MPa (320 kgf/cm ²)
Boom hoist circuit	30.4 MPa (310 kgf/cm ²)
Travel circuit	29.4 MPa (300 kgf/cm ²)

Pilot Circuit

● Main relief valve

.....	4.9 MPa (50 kgf/cm ²)
-------	-----------------------------------

Line Filters

High-filtration 10 μm full-flow filter element is incorporated in the return line. Pilot filter and suction filter are provided in each circuit.

Undercarriage

Traction mechanism

- Each track is driven by an axial piston motor through reduction gear. This mechanism allows counter-rotation of tracks for maneuverability in close quarters.
- When the lever is in neutral position, both hydraulic brake and spring-set/hydraulic-released multiplate disc brake are automatically applied for stopping.

Track Frame

All-welded, stress-relieved, box-section construction

Side Frames

Side frames of all-welded construction can be retracted for transportation.

Side-frame Extending/ Retracting Device

- Side frames are extended and retracted with a hydraulic cylinder located inside the track frame. Hydraulic power source for the hydraulic cylinder is separated from other systems to allow combined operation of travel and side frame.
- The side frames are extended and retracted quickly without need for piping

Track Shoes

Heat-treated alloy steel castings with induction-hardened roller path and driving lugs.

No. of upper rollers (each side).....	2
No. of lower rollers (each side).....	10
No. of track shoes (each side)	59
Shoe width.....	760 mm

Controls

Boom, Main and Auxiliary Hoist, Swing and Travel

Remote controlled hydraulic servo. Working speed can be precisely controlled according to lever stroke.

● Electric Accelerator Grip

Engine power can be controlled according to job needs by electric finger-touch grip atop the swing lever, accelerator lever and accelerator pedal.

● Monitor Displaying Machine Conditions

With the monitor, the operator can check, at a glance, engine oil pressure, water temperature and fuel level, as well as levels of hydraulic oil, engine oil and coolant. The red light turns on and the buzzer sounds in the event of an abnormality.

Safety Device

Boom Angle Indicator

Mechanical-type boom angle indicator is provided at boom foot.

Counterbalance Valves (Brake Valves)

Counterbalance valves are each incorporated in travel motors, boom hoist motor, and main and auxiliary hoist motors. If the hydraulic line is broken, this valve is automatically actuated to prevent motor rotation.

Spring-Set/Hydraulic-Released Multiplate Disc Type Travel Brakes

Swing Lock and Swing Parking Brake

Drum Locks (Electric Type)

A pawl-type drum locks, provided at main drum, auxiliary drum and boom drum, are automatically applied when the engine key is set to OFF or ACC position.

Lever Locks

Main and auxiliary hoist levers, boom hoist lever, and travel levers are each fitted with lock mechanisms to prevent mishandling.

Devices for Crane Operation

● Moment Limiter

On the moment limiter, analog displays and pictorial load indications are functionally arranged for easy reading.

● Hook Overhoist Prevention Device

When the hook reaches its hoist limit, the bell sounds and the auto-stop automatically actuates at the same time.

● Boom Overhoist Prevention Device

When the boom reaches its angle limit, the buzzer alarm sounds and boom hoisting automatically stops at the same time. The telescopic-type boom backstop is also provided.

● Secondary Boom Overhoist Prevention Device

In addition to the hook overhoist prevention device and boom overhoist prevention device, the secondary boom overhoist prevention device is provided. It actuates at a boom angle 82° to avoid overhoisting of both the boom and/ or hook

● Pilot Control Shut-off Lever

The pilot control shut-off lever shuts out the hydraulic pilot pressure to pilot control valves. With the pilot control shut-off lever in the LOCK position, the machine will not operate even if the lever is accidentally shifted.

● Reliable mechanism

The related movements stop automatically if an electric wire is broken.



Service Refill Capacities

	Liter
Fuel tank	300
Engine coolant	27
Engine oil	23
Boom hoist reduction device	9.5
Winch hoist reduction device	12.5×2
Swing reduction device	8
Travel final device	14×2
Hydraulic system, including tank capacity.....	305
Hydraulic tank	230

■ Working Ranges

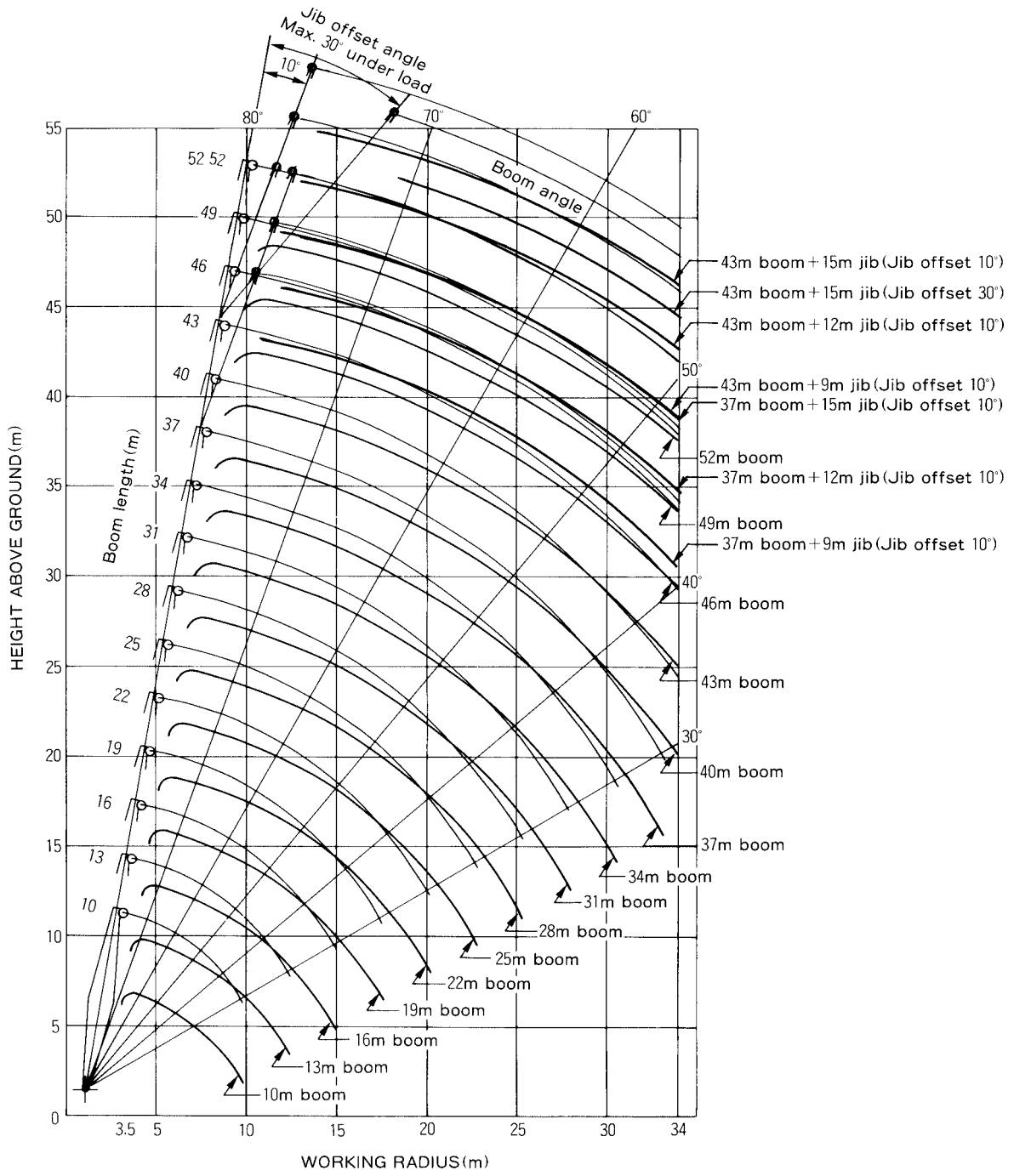

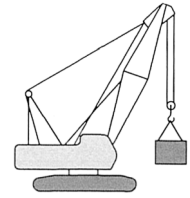

Unit: t

■ Crane Ratings (Main Boom in 360° Working Area)

Working radius (m)	Boom length (m)														
	10	13	16	19	22	25	28	31	34	37	40	43	46	49	52
3.5	50.00	3.8×50.00													
4.0	48.05	47.85	4.4×41.50												
4.5	40.10	39.80	39.75												
5.0	33.75	33.70	33.60	33.60											
5.5	29.25	29.15	29.10	29.05	28.70										
6.0	25.75	25.70	25.60	25.60	25.50	6.1×24.80	6.7×21.75								
7.0	20.75	20.70	20.60	20.55	20.50	20.45	20.35	7.3×19.35	7.8×17.30						
8.0	17.35	17.25	17.20	17.15	17.05	17.00	16.95	16.90	16.80	8.4×15.65					
9.0	14.90	14.80	14.70	14.65	14.55	14.50	14.45	14.45	14.30	14.20	14.20	9.6×13.00			
10.0	9.8×12.65	12.90	12.80	12.75	12.65	12.60	12.50	12.50	12.40	12.30	12.30	12.20	10.1×11.95	10.7×10.70	11.3×9.45
12.0		10.25	10.10	10.05	9.95	9.90	9.80	9.80	9.70	9.60	9.60	9.50	9.40	9.35	9.20
14.0		12.4×9.80	8.30	8.25	8.15	8.10	8.00	7.95	7.85	7.75	7.75	7.65	7.55	7.50	7.45
16.0			15.0×7.60	6.95	6.85	6.80	6.70	6.65	6.55	6.45	6.40	6.35	6.25	6.15	6.10
18.0				17.6×6.15	5.85	5.80	5.70	5.65	5.55	5.45	5.45	5.35	5.25	5.15	5.10
20.0					5.10	5.05	4.95	4.85	4.75	4.70	4.65	4.55	4.45	4.40	4.30
22.0					20.2×5.05	4.40	4.35	4.25	4.15	4.05	4.00	3.95	3.85	3.75	3.65
24.0						22.8×4.20	3.80	3.75	3.65	3.55	3.50	3.40	3.35	3.25	3.15
26.0							25.4×3.50	3.30	3.20	3.15	3.10	3.00	2.90	2.80	2.70
28.0								2.95	2.85	2.75	2.70	2.65	2.50	2.40	2.30
30.0									2.55	2.45	2.40	2.30	2.15	2.05	1.95
32.0									30.6×2.40	2.20	2.10	2.00	1.85	1.75	1.65
34.0										33.2×1.90	1.80	1.75	1.60	1.50	1.35

Notes: 1. The rated loads shown do not exceed 78% of tipping load with the machine on firm level ground, and are not less than 1.15 times over-front stability stipulated by the mobile crane construction standards.

2. The calculate the maximum load that can actually be lifted, deduct weight of all lifting accessories, such as main hook, from figures shown above.

3. Working radius is the horizontal distance from the swing center to the center of gravity of a lifted load.

4. When the jib or the auxiliary jib is attached to the load to be actuarially lifted is the rated load minus the weight lifted below and the weight of the main and auxiliary hooks. Be careful that if the calculated load is less than 0.8 t, no crane operation is allowed.

Jib length (m)	6	9	12	15	Aux. Jib
Weight to be reduced (t)	0.75	0.90	1.05	1.20	0.30

5. The counterweight is 16.9 t.

6. Be sure to fully extend the side frames before operating the machine.

7. Correlations between the number of hoist rope reevings, maximum rated loads, hook weights are shown in the table below.

Hook capacity (t)	Hook weight (t)	Maximum rated load (t)							
		8 Rope reevings	7 Rope reevings	6 Rope reevings	5 Rope reevings	4 Rope reevings	3 Rope reevings	2 Rope reevings	1 Rope* reeving
50	0.61	50.0	45.5	39.0	32.5	26.0	19.5	13.0	—
30	0.36	—	—	—	30.0	26.0	19.5	13.0	—
15	0.32	—	—	—	—	—	19.5	13.0	—
6.5	0.18	—	—	—	—	—	—	—	6.5

* The boom length should be at least 13 m when operating the machine with a single suspension line.

8. Figures described as ○○×○○ in the tables indicate working radius (m) × rated load (t).

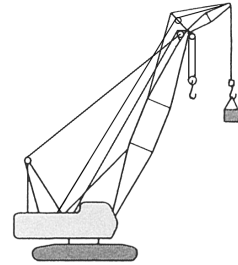

Crane Ratings (Jib in 360° Working Area)

Unit: t

Boom length (m)	22								25							
Jib length (m)	6		9		12		15		6		9		12		15	
Offset angle (°)	10	30	10	30	10	30	10	30	10	30	10	30	10	30	10	30
Working radius (m)																
8.1	6.50									8.8×6.50						
9.0	6.50	9.9×6.50	9.3×5.00							6.50		9.9×5.00				
10.0	6.50	6.50	5.00	11.9×5.00	10.4×4.10			11.5×3.30		6.50	10.5×6.50	5.00		11.0×4.10		
12.0	6.50	6.50	5.00	5.00	4.10	13.9×4.10	3.30			6.50	6.50	5.00	12.5×5.00	4.10		12.1×3.30
14.0	6.50	6.50	5.00	5.00	4.10	4.10	3.30	15.9×3.30		6.50	6.50	5.00	5.00	4.10	14.5×4.10	3.30
16.0	6.50	6.50	5.00	5.00	4.10	4.10	3.30	3.30	6.50	6.50	5.00	5.00	4.10	4.10	3.30	16.5×3.30
18.0	5.80	5.90	5.00	5.00	4.10	4.00	3.30	3.25	5.70	5.85	5.00	5.00	4.10	4.10	3.30	3.30
20.0	5.00	5.10	5.00	4.85	4.10	3.75	3.30	3.05	4.95	5.05	4.40	5.00	4.10	3.85	3.30	3.15
22.0	4.40	4.45	4.45	4.55	4.10	3.55	3.30	2.85	4.30	4.40	3.85	4.50	4.10	3.65	3.30	2.95
24.0	3.90	3.90	3.95	4.00	4.00	3.35	3.30	2.70	3.80	3.85	3.45	3.95	3.90	3.45	3.30	2.80
26.0	3.45	3.50	3.50	3.60	3.55	3.20	3.30	2.55	3.35	3.40	3.05	3.50	3.50	3.30	3.30	2.65
28.0	26.1×3.45	26.5×3.35	3.15	3.20	3.20	3.05	3.10	2.45	3.00	3.05	2.75	3.15	3.10	3.20	3.15	2.55
30.0			28.9×3.00	29.5×2.85	2.90	2.95	2.90	2.30	28.7×2.80	29.1×2.75	31.5×2.45	2.80	2.80	2.90	2.85	2.45
32.0					31.8×2.55	2.65	2.65	2.25				2.40	2.55	2.60	2.55	2.35
34.0						32.5×2.50	2.40	2.20				32.1×2.40	2.20	2.35	2.30	2.25

Boom length (m)	28								31								
Jib length (m)	6		9		12		15		6		9		12		15		
Offset angle (°)	10	30	10	30	10	30	10	30	10	30	10	30	10	30	10	30	
Working radius (m)																	
9.4	6.50																
10.0	6.50	11.1×6.50	10.5×5.00			11.6×4.10				6.50	11.8×6.50	11.1×5.00					
12.0	6.50	6.50	5.00	13.2×5.00	4.10			12.7×3.30		6.50	6.50	5.00	13.8×5.00	12.2×4.10		13.4×3.30	
14.0	6.50	6.50	5.00	5.00	4.10	15.2×4.10	3.30			6.50	6.50	5.00	5.00	4.10	15.8×4.10	3.30	
16.0	6.50	6.50	5.00	5.00	4.10	4.10	3.30	17.2×3.30		6.50	6.50	5.00	5.00	4.10	4.10	3.30	17.8×3.30
18.0	5.60	5.75	5.00	5.00	4.10	4.10	3.30	3.30	5.55	5.70	5.00	5.00	4.10	4.10	3.30	3.30	
20.0	4.85	4.95	4.90	5.00	4.10	4.00	3.30	3.20	4.75	4.90	4.85	5.00	4.10	4.10	3.30	3.30	
22.0	4.20	4.30	4.25	4.40	4.10	3.75	3.30	3.05	4.15	4.20	4.20	4.35	4.10	3.90	3.30	3.10	
24.0	3.70	3.75	3.75	3.85	3.80	3.60	3.30	2.90	3.60	3.70	3.70	3.80	3.75	3.70	3.30	2.95	
26.0	3.25	3.30	3.30	3.40	3.40	3.40	3.30	2.75	3.20	3.25	3.25	3.35	3.30	3.45	3.30	2.80	
28.0	2.90	2.95	2.95	3.05	3.00	3.10	3.05	2.60	2.80	2.85	2.90	2.95	2.95	3.05	3.00	2.70	
30.0	2.60	2.60	2.65	2.70	2.70	2.80	2.75	2.50	2.50	2.55	2.55	2.65	2.60	2.75	2.65	2.60	
32.0	31.3×2.30	31.7×2.30	2.35	2.40	2.40	2.50	2.45	2.40	2.25	2.25	2.30	2.35	2.35	2.45	2.40	2.50	
34.0			2.05	2.10	2.20	2.25	2.20	2.30	33.9×1.90	1.95	2.05	2.10	2.10	2.20	2.15	2.25	

Boom length (m)	34								37								
Jib length (m)	6		9		12		15		6		9		12		15		
Offset angle (°)	10	30	10	30	10	30	10	30	10	30	10	30	10	30	10	30	
Working radius (m)																	
10.6	6.50		11.7×5.00							11.2×6.50							
12.0	6.50	12.4×6.50	5.00			12.9×4.10				6.50	13.0×6.50	12.4×5.00		13.5×4.10			
14.0	6.50	6.50	5.00	14.4×5.00	4.10		3.30			6.50	6.50	5.00	15.0×5.00	4.10		14.6×3.30	
16.0	6.45	6.50	5.00	5.00	4.10	16.4×4.10	3.30			6.35	6.50	5.00	5.00	4.10	17.0×4.10	3.30	
18.0	5.45	5.60	5.00	5.00	4.10	4.10	3.30	18.4×3.30		5.35	5.50	5.00	5.00	4.10	4.10	3.30	19.0×3.30
20.0	4.65	4.80	4.75	4.95	4.10	4.10	3.30	3.30	4.55	4.70	4.65	4.85	4.10	4.10	3.30	3.30	
22.0	4.05	4.15	4.10	4.30	4.10	3.95	3.30	3.20	3.95	4.05	4.00	4.20	4.10	4.05	3.30	3.25	
24.0	3.50	3.60	3.60	3.75	3.65	3.80	3.30	3.05	3.40	3.50	3.50	3.65	3.55	3.80	3.30	3.10	
26.0	3.10	3.15	3.15	3.25	3.20	3.40	3.25	2.90	3.00	3.05	3.05	3.20	3.10	3.30	3.15	2.95	
28.0	2.70	2.80	2.80	2.90	2.85	3.00	2.90	2.75	2.60	2.70	2.70	2.80	2.75	2.90	2.80	2.85	
30.0	2.40	2.45	2.45	2.55	2.50	2.65	2.55	2.65	2.25	2.35	2.35	2.45	2.40	2.55	2.45	2.65	
32.0	2.10	2.15	2.15	2.25	2.25	2.35	2.30	2.45	1.95	2.05	2.05	2.15	2.10	2.25	2.15	2.35	
34.0	1.85	1.85	1.90	2.00	1.95	2.10	2.00	2.15	1.70	1.75	1.80	1.90	1.85	2.00	1.90	2.10	

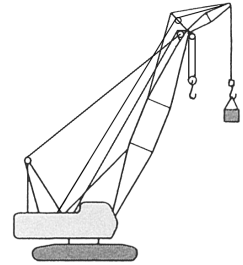

Unit: t

Boom length (m)	40								43								
Jib length (m)	6		9		12		15		6		9		12		15		
Offset angle (°)	10	30	10	30	10	30	10	30	10	30	10	30	10	30	10	30	
Working radius (m)																	
11.9	6.50																
12.0	6.50	13.6×6.50	13.0×5.00							12.5×6.50		13.6×5.00					
14.0	6.50	6.50	5.00	15.6×5.00	14.1×4.10			15.2×3.30		6.50	14.3×6.50	5.00		14.7×4.10			
16.0	6.30	6.50	5.00	5.00	4.10	17.7×4.10	3.30			6.25	6.45	5.00	16.3×5.00	4.10		15.9×3.30	
18.0	5.30	5.50	5.00	5.00	4.10	4.10	3.30	19.7×3.30	5.20	5.40	5.00	5.00	4.10	18.3×4.10	3.30		
20.0	4.50	4.65	4.60	4.85	4.10	4.10	3.30	3.30	4.40	4.60	4.50	4.75	4.10	4.10	3.30	20.3×3.30	
22.0	3.90	4.00	3.95	4.15	4.05	4.10	3.30	3.30	3.80	3.90	3.85	4.10	3.95	4.10	3.30	3.30	
24.0	3.35	3.45	3.45	3.60	3.50	3.75	3.30	3.15	3.25	3.40	3.35	3.50	3.40	3.65	3.30	3.20	
26.0	2.90	3.00	3.00	3.15	3.05	3.25	3.10	3.00	2.80	2.95	2.90	3.05	2.95	3.20	3.00	3.05	
28.0	2.55	2.65	2.60	2.75	2.70	2.85	2.75	2.90	2.40	2.55	2.50	2.65	2.60	2.80	2.65	2.90	
30.0	2.20	2.30	2.25	2.40	2.35	2.50	2.40	2.60	2.05	2.15	2.15	2.30	2.20	2.45	2.30	2.55	
32.0	1.90	1.95	1.95	2.10	2.00	2.20	2.10	2.30	1.75	1.85	1.85	2.00	1.90	2.10	1.95	2.55	
34.0	1.60	1.70	1.70	1.80	1.75	1.90	1.80	2.00	1.50	1.55	1.55	1.70	1.65	1.80	1.70	1.95	

Notes: 1. The rated loads shown do not exceed 78% of tipping load with the machine on firm level ground, and are not less than 1.15 times over-front stability stipulated by the mobile crane construction standards.

2. To calculate the maximum load that can actually be lifted, deduct weight of all lifting accessories, such as main hook, from figures shown above.

Hook capacity (t)	Weight (t)
50	0.61
30	0.36
15	0.32
6.5	0.18

3. Working radius is the horizontal distance from the swing center to the center of gravity of a lifted load.

4. Jib offset angle to main boom is set to loading condition.

5. The counterweight is 16.9 t.

6. Be sure to fully extend the side frames before operating the machine.

7. Figures described as ○○×○○ in the tables indicate working radius (m) × rated load (t).

■Crane Boom Construction

Boom length (m)		10	13	16	19	22	25	28	31	34	37	40	43	46	49	52							
Elements																							
Lower boom	5 m	1	1	1	1	1	1	1	1	1	1	1	1	1	1	1							
Upper boom	5 m	1	1	1	1	1	1	1	1	1	1	1	1	1	1	1							
Boom insert combination		I	II	I	II	I	II	I	II	I	II	I	II	I	II	I	II						
3 m boom insert			1		2		1		2	1	1	2	1	1	2	2	1	1	2	2			
6 m boom insert						1		1		2		1	1	1	1	2	2	2	2	3	3	3	3
9 m boom insert									1		1		1		2	1	2	1	2	1	2	1	1
9 m (B) boom insert							1		1		1		1		1		1		1		1		1
Available jib																							
Available aux. jib																							

Boom inserts combination:

I : For operation of crane boom only

II : For operation of crane boom with jib

6 m boom insert can be replaced with two 3 m boom inserts, and 9 m boom insert with a combination of 3 m and 6 m boom inserts.

Note: When purchasing a 22 m boom, the boom cannot be transformed to 16 m in case of type II boom inserts. In this case, an additional 3 m boom insert is required.

■Crane Jib Construction

Jib length (m)		6	9	12	15
Elements					
Lower jib	3 m	1	1	1	1
Upper jib	3 m	1	1	1	1
3 m jib insert			1	2	3

■Component Weights and Dimensions for Transport

Components		Weight (t)	Length × Width × Height (m)			Remarks
Basic machine	Basic machine	29.50	6.63	3.30	3.20	Excluding lower boom, ropes and counterweight
	Counterweight	7.25	3.24	0.47	1.50	Inner
	Counterweight	9.65	3.24	0.59	1.52	Outer
Crane front	Lower boom	0.80	5.15	1.55	1.54	
	Upper boom	0.98	5.40	1.39	1.47	
	Backstop	0.13	4.00	0.13	0.13	
	Rise rope	0.17	1.00	1.00	0.90	
	Bridle	0.26	1.65	0.78	0.25	
	3 m boom insert	0.22	3.10	1.40	1.46	
	6 m boom insert	0.38	6.10	1.40	1.46	
	9 m boom insert	0.56	9.10	1.40	1.46	
	9 m (B) boom insert	0.59	9.10	1.40	1.49	
	Lower jib	0.15	3.20	0.72	0.63	
	Upper jib	0.17	3.35	0.66	0.60	
	3 m jib insert	0.08	3.06	0.72	0.60	
	Jib mast	0.18	3.20	0.72	0.64	
	50 t hook	0.61	1.61	0.62	0.42	
	30 t hook	0.36	1.51	0.62	0.30	
15 t hook	0.32	1.36	0.62	0.29		
6.5 t hook	0.18	0.84	0.30	0.30		

■Dimensions

Unit: mm

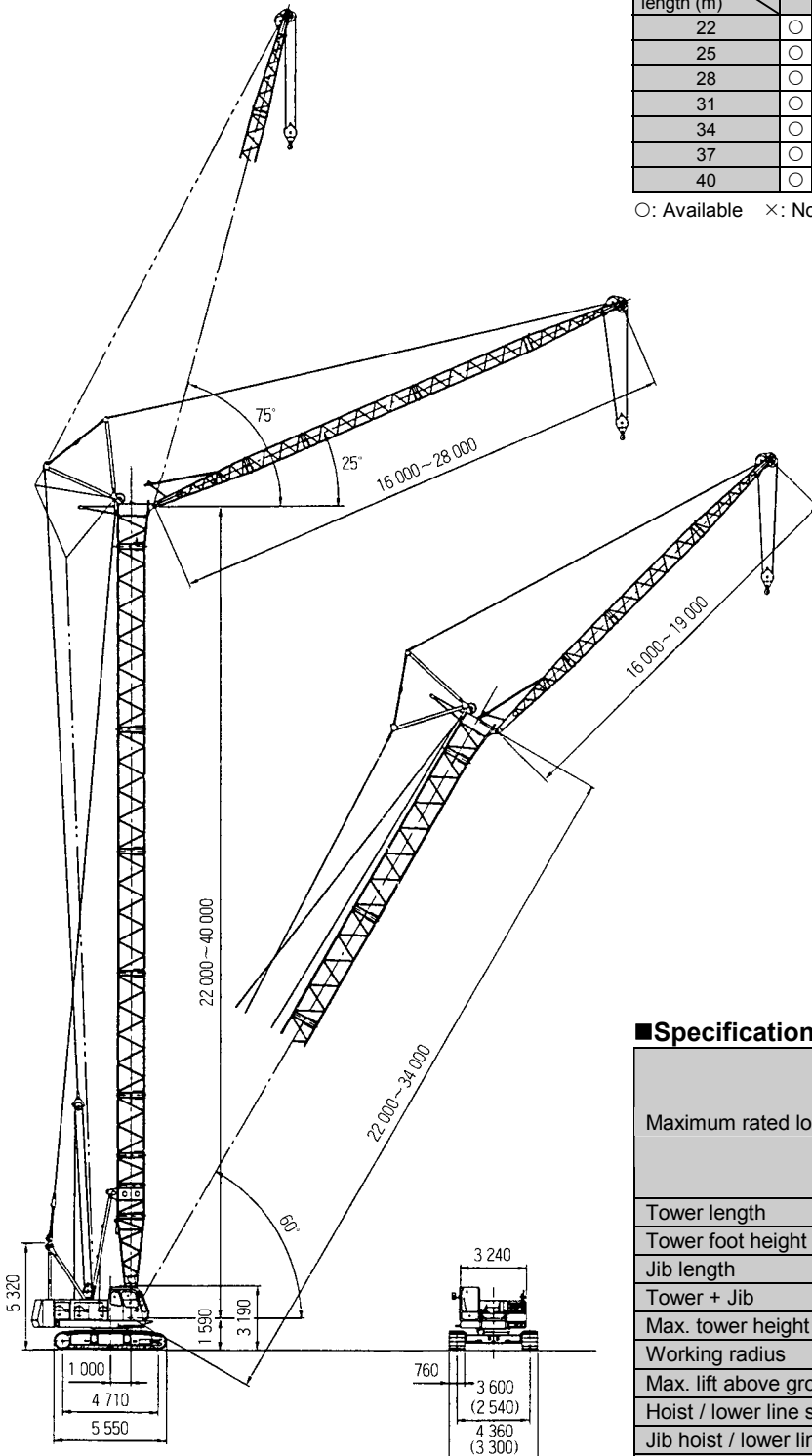

Figures in () indicate crawlers retracted.

■Tower Jib Construction

Jib length (m)	16				19				22				25				28			
Tower angle (°)	90	80	70	60	90	80	70	60	90	80	70	60	90	80	70	60	90	80	70	60
Tower length (m)																				
22	○	○	○	○	○	○	○	○	×	×	×	×	×	×	×	×	×	×	×	×
25	○	○	○	○	○	○	○	○	○	○	○	○	×	×	×	×	×	×	×	×
28	○	○	○	○	○	○	○	○	○	○	○	○	○	○	○	○	×	×	×	×
31	○	○	○	○	○	○	○	○	○	○	○	×	○	○	○	×	○	○	○	×
34	○	○	○	○	○	○	○	○	○	○	○	○	×	○	○	×	○	○	○	×
37	○	○	○	×	○	○	○	×	○	○	○	×	○	○	○	×	○	○	○	×
40	○	○	○	×	○	○	○	×	○	○	○	×	○	○	×	×	×	×	×	×

○: Available ×: Not available

■Specifications

(1 t = 1 000 kg)

Maximum rated load	t × m	11.4 × 10.3 (22 m tower + 16 m jib)
		10.3 × 11.1 (22 m tower + 19 m jib)
		9.4 × 11.0 (28 m tower + 22 m jib)
		6.15 × 13.0 (37 m tower + 28 m jib)
		6.45 × 12.0 (40 m tower + 25 m jib)
Tower length	m	22 to 40
Tower foot height	m	1.59
Jib length	m	16 to 28
Tower + Jib	m	40+25
Max. tower height above ground	m	41.6
Working radius	m	8.0 to 38.1
Max. lift above ground	m	63
Hoist / lower line speeds	m/min	*110/74/37
Jib hoist / lower line speed	m/min	*37
Tower hoist / lower line speed	m/min	*60
Ground pressure	kPa (kgf/cm ²)	71.1 (0.73)
Operating weight	t	55.2 (40 m tower + 2.5 m jib)

Notes: 1. Data is expressed in SI units, followed by conventional units in ().

2. Other specifications, not shown, are similar to those for the crane.

*Line speeds will vary with the load.

22 m Tower (2-Rope Reeving)

Rated Loads for Tower Crane

Unit: t

Working radius (m)	Jib length (m)							
	16 m				19 m			
	90°	80°	70°	60°	90°	80°	70°	60°
8.0	11.50				9.0×11.40			
9.0	11.50				9.5×11.25			
10.0	10.3×11.40				10.90			
12.0	9.50	12.9×5.85			11.1×10.30			
14.0	7.80	5.85			7.80	14.2×5.20		
16.0	6.60	5.15			6.60	5.10		
18.0	16.7×6.30	4.45	18.9×3.70		5.70	4.45		
20.0		3.95	3.65		19.4×5.20	3.90	20.7×3.30	
22.0		20.5×3.80	3.25			3.50	3.20	
24.0			2.95	24.4×2.55		23.2×3.30	2.90	
26.0			24.2×2.95	2.45			2.65	26.6×2.25
28.0				27.6×2.30			26.9×2.50	2.20
30.0								2.00
30.3								2.00

- Notes:
- The rated loads shown do not exceed 78% of tipping load with the machine on firm level ground, and are not less than 1.15 times over-front stability stipulated by mobile crane construction standards.
 - The load to be actually lifted will be the rated load shown minus the weight of all lifting attachments such as a hook.
15 ton hook weight 0.32 t
 - Working radius is a horizontal distance between swing center of the machine and center of gravity of the load lifted.
 - Counterweight is 16.9 t.
 - In operation with 1-rope reeving, use a 6.5 t hook (option). In this case, the rated loads for tower crane (with 1-rope reeving) described in the Operation Manual will be applied.
 - Crawlers must be extended into position before crane operation.
 - Figures described as ○○×○○ in the tables indicate working radius (m) × rated load (t).

Working Ranges

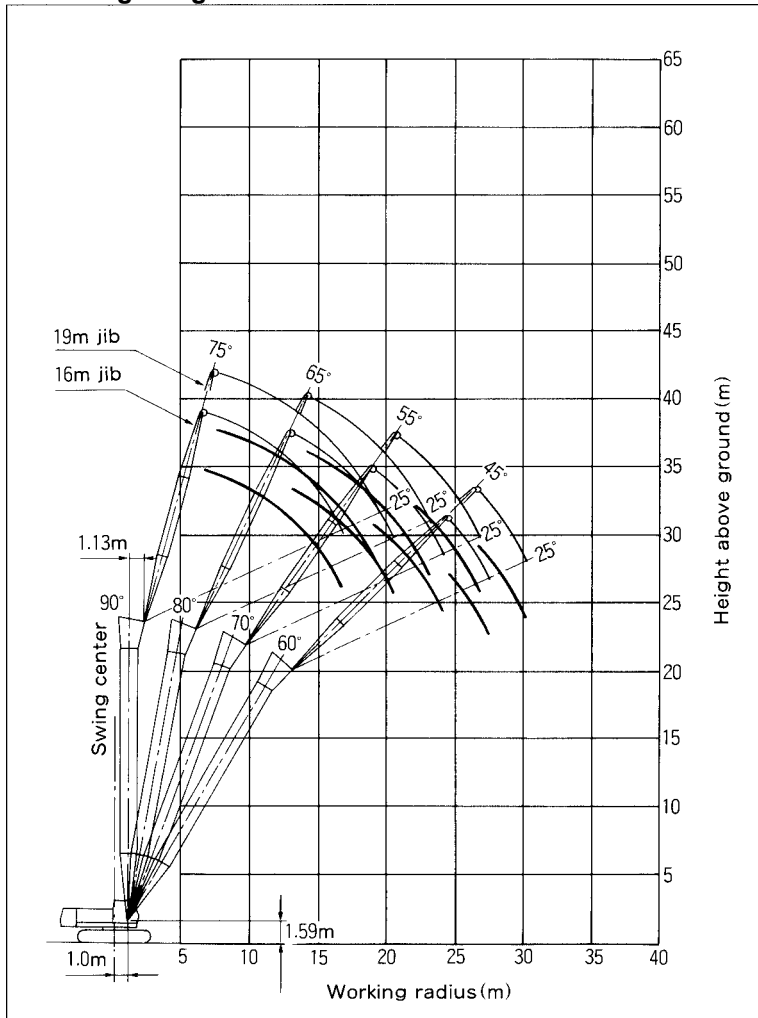

Working ranges are shown for unloading.

25 m Tower (2-Rope Reeving)

Rated Loads for Tower Crane

Unit: t

Working radius (m)	Jib length (m)											
	16m				19m				22m			
	90°	80°	70°	60°	90°	80°	70°	60°	90°	80°	70°	60°
8.1	11.50											
9.0	11.50				9.1×10.50							
10.0	9.5×11.40				10.50					10.0×9.40		
12.0	10.7×10.90	13.4×5.50			11.6×9.75					9.00		
14.0	7.80	5.50			7.80	14.7×4.90				12.5×8.80	15.9×4.35	
16.0	6.60	5.05			6.60	4.90				6.60	4.35	
18.0	16.7×6.30	4.40			5.80	4.35				5.70	4.30	
20.0		3.90	3.40		19.4×5.20	3.85	21.7×3.00			5.00	3.80	
22.0		21.0×3.65	3.15			3.45	3.00			4.40	3.40	23.4×2.70
24.0			2.85	25.9×2.25		23.8×3.10	2.80			22.2×4.35	3.05	2.70
26.0			25.2×2.65	2.25			2.55				2.75	2.50
28.0				2.15			27.9×2.30	28.1×2.00		26.5×2.65	2.25	
30.0				29.1×2.05				1.90			2.05	30.6×1.75
32.0								31.8×1.75			30.2×1.75	1.70
34.0												1.55
34.5												1.50

For notes, refer to those on the 22 m tower.

Working Ranges

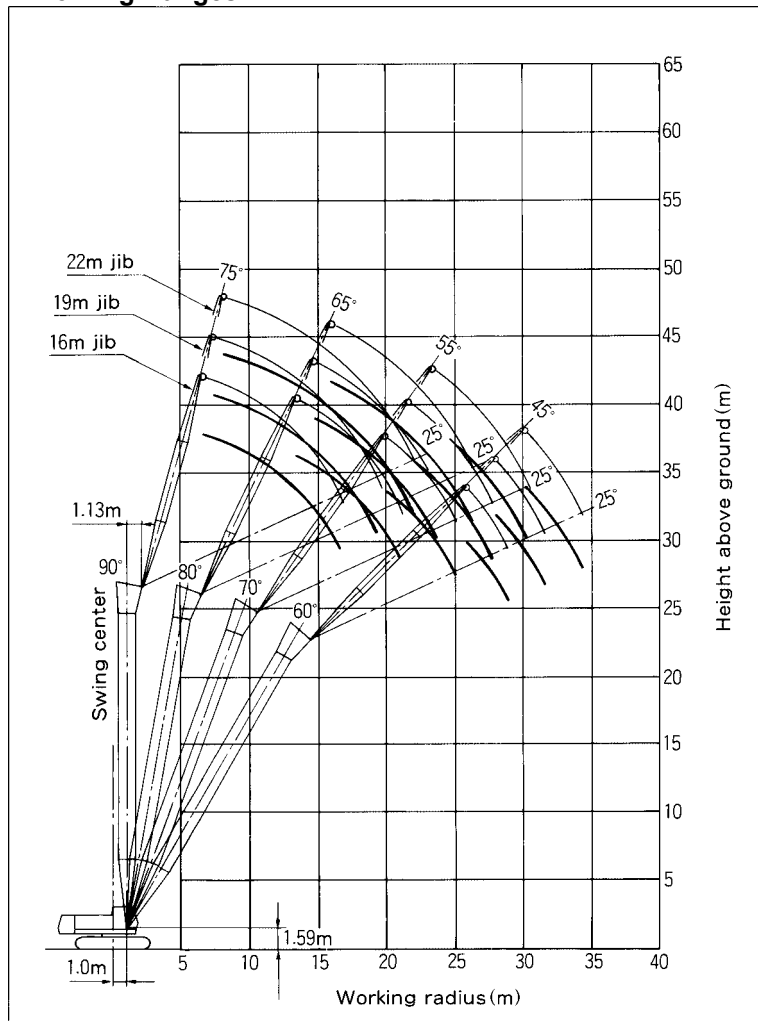

Working ranges are shown for unloading.

28 m Tower (2-Rope Reeving)

Rated Loads for Tower Crane

Unit: t

Working radius (m)	Jib length (m)														
	16m				19m				22m				25m		
	90°	80°	70°	60°	90°	80°	70°	60°	90°	80°	70°	60°	90°	80°	70°
8.3	11.40														
9.0	11.40				9.2×10.50				10.1×9.40						
10.0	9.5×11.40				10.50				11.0×9.40				11.1×8.20		
12.0	10.7×10.90	13.9×5.15			11.6×9.75				9.00				8.20		
14.0	7.80	5.15			7.80	15.2×4.60			12.5×8.80				7.30		
16.0	6.60	5.00			6.60	4.60			6.60	16.5×4.10			15.5×6.70	17.7×3.70	
18.0	16.7×6.30	4.35			5.80	4.30			5.70	4.10			5.70	3.70	
20.0		3.80	21.0×3.05		19.4×5.20	3.80			5.00	3.70			5.00	3.65	
22.0		21.6×3.50	3.05			3.35	22.7×2.75		4.40	3.30			4.40	3.25	
24.0			2.75			3.05	2.70		22.2×4.35	2.95	24.4×2.45		3.90	2.95	
26.0			2.50	27.4×2.00		24.3×3.00	2.45			2.70	2.40		24.9×3.65	2.65	26.1×2.20
28.0			26.2×2.45	2.00			2.25	29.6×1.75		27.0×2.55	2.15			2.40	2.10
30.0				1.85			28.9×2.10	1.75			2.00	31.7×1.55		29.7×2.20	1.95
32.0				30.6×1.80				1.65			31.7×1.85	1.55			1.80
34.0								33.3×1.55				1.45			1.65
36.0												1.35			34.4×1.60

For notes, refer to those on the 22 m tower.

Working Ranges

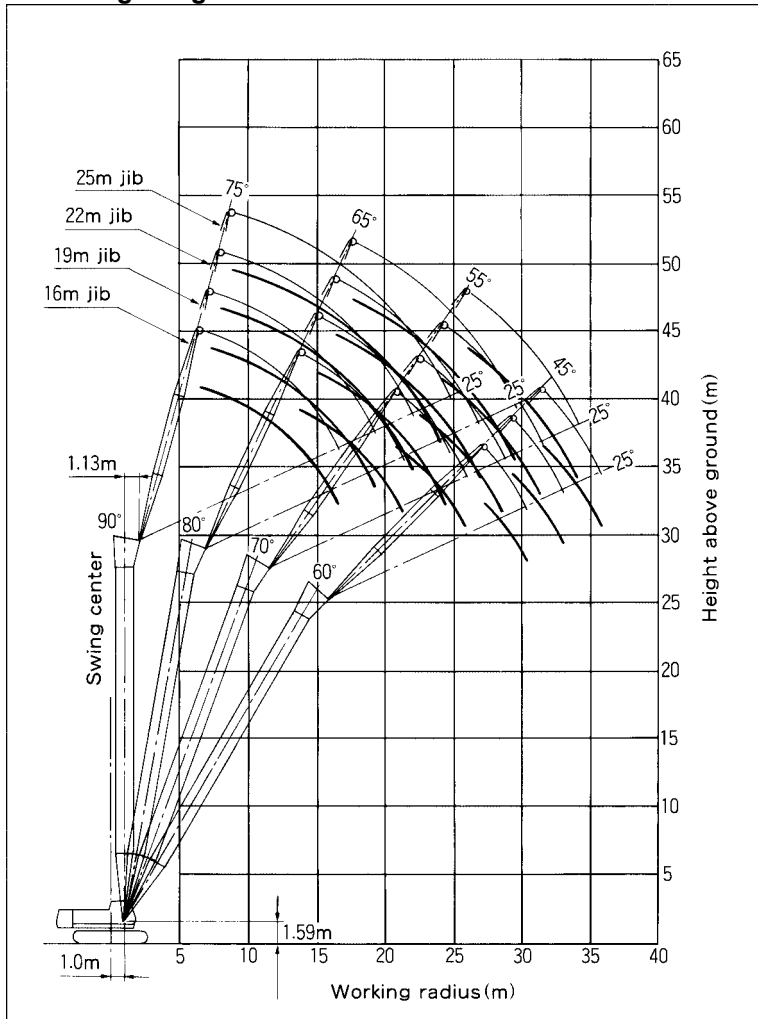

Working ranges are shown for unloading.

31 m Tower (2-Rope Reeving)

Rated Loads for Tower Crane

Unit: t

Working radius (m)	Jib length (m)																		
	16m				19m				22m			25m			28m				
	90°	80°	70°	60°	90°	80°	70°	60°	90°	80°	70°	90°	80°	70°	90°	80°	70°		
8.4	10.40																		
9.0	10.40				9.3×10.00							10.2×8.40							
10.0	10.00				10.00							11.0×8.40					12.1×6.20		
12.0	9.40				8.70							8.10			7.55			13.0×6.15	
14.0	7.80	14.4×4.80			13.1×8.35	15.7×4.30						14.2×7.55			7.05			5.80	
16.0	6.60	4.80			6.60	4.30						6.50	17.0×3.85		15.5×6.70			5.20	
18.0	16.7×6.30	4.25			5.80	4.20						5.70	3.85		5.60	18.3×3.50		4.70	19.5×3.15
20.0		3.75			19.4×5.20	3.70						5.00	3.65		4.90	3.50		4.20	3.15
22.0		3.35	2.75			3.30	23.7×2.50					4.40	3.25		4.40	3.20		3.80	3.15
24.0		22.1×3.30	2.65			2.95	2.50					22.2×4.35	2.90	25.5×2.20	3.90	2.85		3.40	2.80
26.0			2.40			24.8×2.80	2.35						2.65	2.20	24.9×3.65	2.60	27.2×2.00	3.00	2.55
28.0			27.3×2.25	28.9×1.75			2.15						27.5×2.45	2.10	2.35	2.00	27.6×2.75	2.30	28.9×1.80
30.0				1.75			1.95	31.1×1.55						1.90	2.15	1.85		2.10	1.80
32.0				1.60				1.55						1.75	30.2×2.10	1.70		1.95	1.65
34.0				32.1×1.60				1.40						32.7×1.70			1.55	33.0×1.85	1.50
36.0								34.8×1.35									35.4×1.45		1.40
38.0																			1.30
38.1																			1.30

For notes, refer to those on the 22 m tower.

Working Ranges

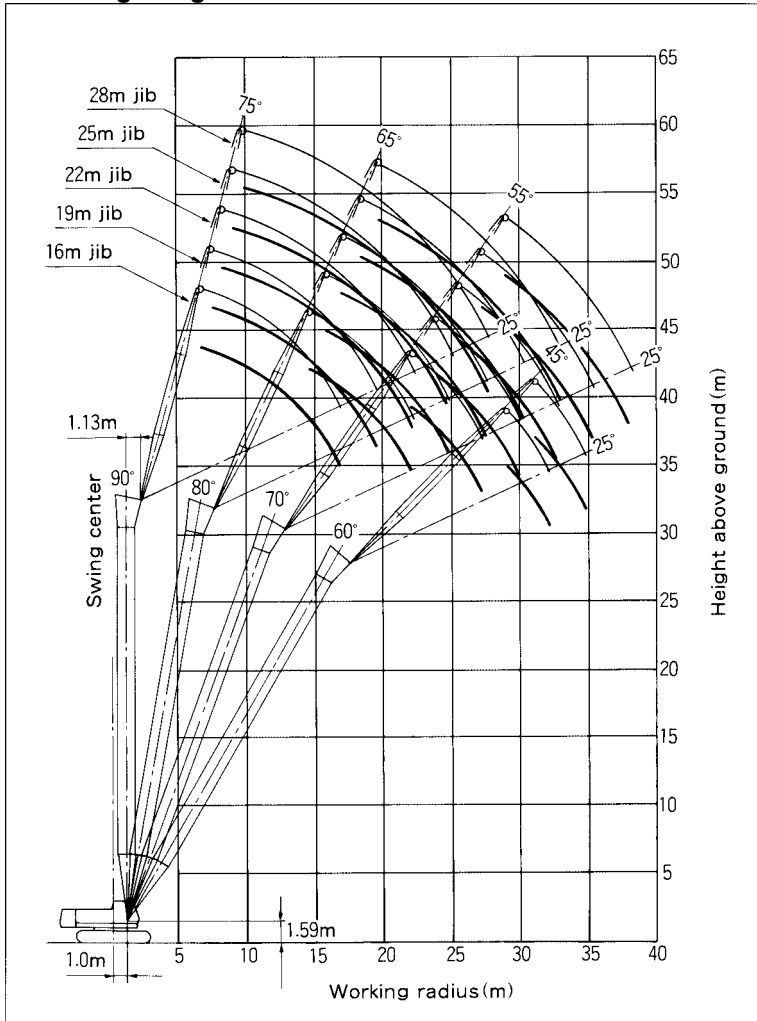

Working ranges are shown for unloading.

34 m Tower (2-Rope Reeving)

Rated Loads for Tower Crane

Unit: t

Working radius (m)	Jib length (m)															
	16m				19m				22m			25m			28m	
	90°	80°	70°	60°	90°	80°	70°	60°	90°	80°	70°	90°	80°	70°	90°	80°
8.5	10.40															
9.0	10.40				9.4×9.50				10.3×8.40							
10.0	10.00				9.35				11.0×8.40			11.3×7.60			12.2×6.20	
12.0	9.40				8.70				8.10			7.55			13.0×6.15	
14.0	7.80	15.0×4.50			13.1×8.35				14.2×7.55			7.05			5.80	
16.0	6.60	4.50			6.60	16.2×4.05			6.50	17.5×3.65		15.5×6.70			5.20	
18.0	16.7×6.30	4.15			5.80	4.05			5.70	3.65		5.60	18.3×3.30		4.70	
20.0		3.65			19.4×5.20	3.60			5.00	3.55		4.90	3.30		4.20	3.00
22.0		3.25	23.0×2.50			3.25			4.40	3.15		4.40	3.10		3.80	3.00
24.0		22.6×3.15	2.50			2.90	24.8×2.25		22.2×4.35	2.85		3.90	2.80		3.40	2.75
26.0			2.30			25.3×2.70	2.25			2.55	26.5×2.00	24.9×3.65	2.55		3.00	2.45
28.0			2.10				2.05			2.35	2.00		2.30	28.2×1.80	27.6×2.75	2.25
30.0			28.3×2.05	30.4×1.50			1.85				1.80		2.10	1.75		2.05
32.0				1.45			31.0×1.80	32.6×1.35			1.65		30.8×2.00	1.60		1.90
34.0				33.6×1.35				1.30			33.7×1.55			1.50		33.5×1.80
36.0								1.20						1.35		
36.4								36.3×1.20						1.30		

For notes, refer to those on the 22 m tower.

Working Ranges

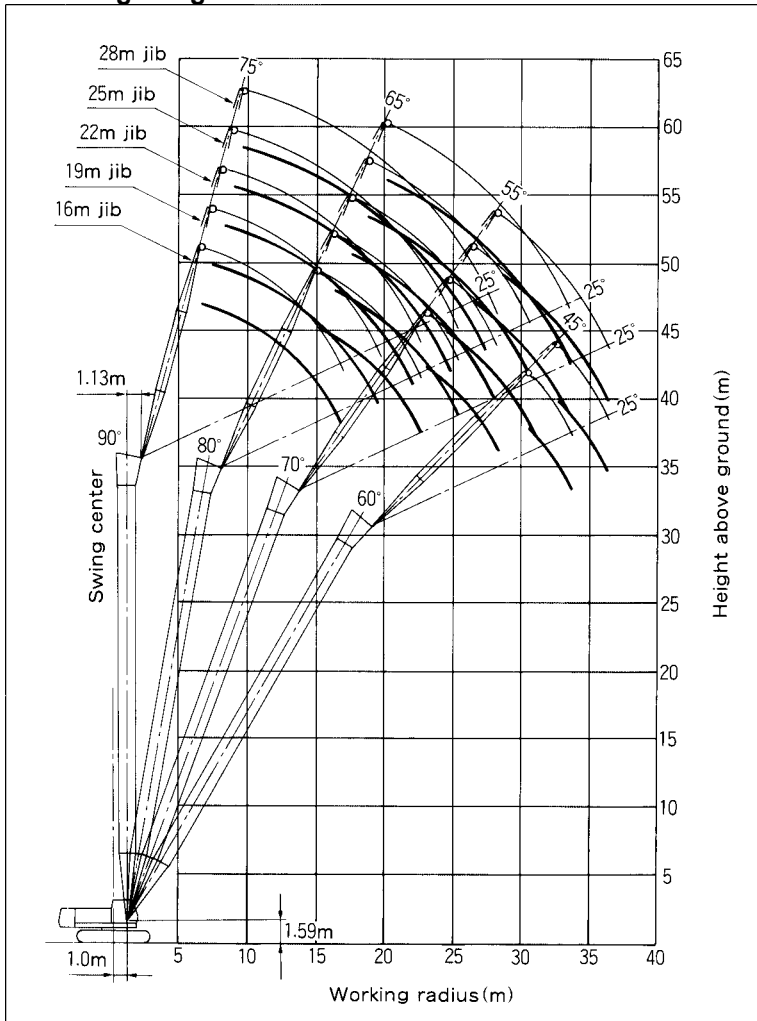

Working ranges are shown for unloading.

37 m Tower (2-Rope Reeving)

Rated Loads for Tower Crane

Unit: t

Working radius (m)	Jib length (m)													
	16m			19m			22m			25m			28m	
	90°	80°	70°	90°	80°	70°	90°	80°	70°	90°	80°	70°	90°	80°
8.6	8.60													
9.0	8.60			9.5×8.00			10.4×7.20							
10.0	8.40			8.00			11.0×7.10				11.4×6.50			12.3×6.15
12.0	8.05			8.00			6.90				6.45			13.0×6.15
14.0	7.75	15.5×4.20		15.2×6.95			6.50				6.10			5.80
16.0	6.60	4.20		6.60	16.8×3.80		16.7×6.15				5.75			5.20
18.0	16.7×6.30	4.05		5.70	3.80		5.60	3.40			18.2×5.50	19.3×3.10		4.70
20.0		3.60		19.4×5.20	3.55		5.00	3.40			4.90	3.10		4.20
22.0		3.20			3.15		4.40	3.10			4.40	3.05		3.80
24.0		23.1×3.00	24.1×2.30		2.85	25.8×2.05	22.2×4.35	2.75			3.90	2.75		3.40
26.0			2.20		25.8×2.55	2.05		2.50	27.5×1.80	24.9×3.65	2.45			3.00
28.0			2.00			1.95		2.30	1.80		2.25	29.2×1.60	27.6×2.75	2.20
30.0			29.3×1.85			1.75		28.6×2.20	1.70		2.05	1.60		2.00
32.0						1.60			1.55		31.3×1.90	1.50		1.80
34.0									1.45			1.40		1.70
36.0									34.7×1.40			1.30		
37.5												1.20		

For notes, refer to those on the 22 m tower.

Working Ranges

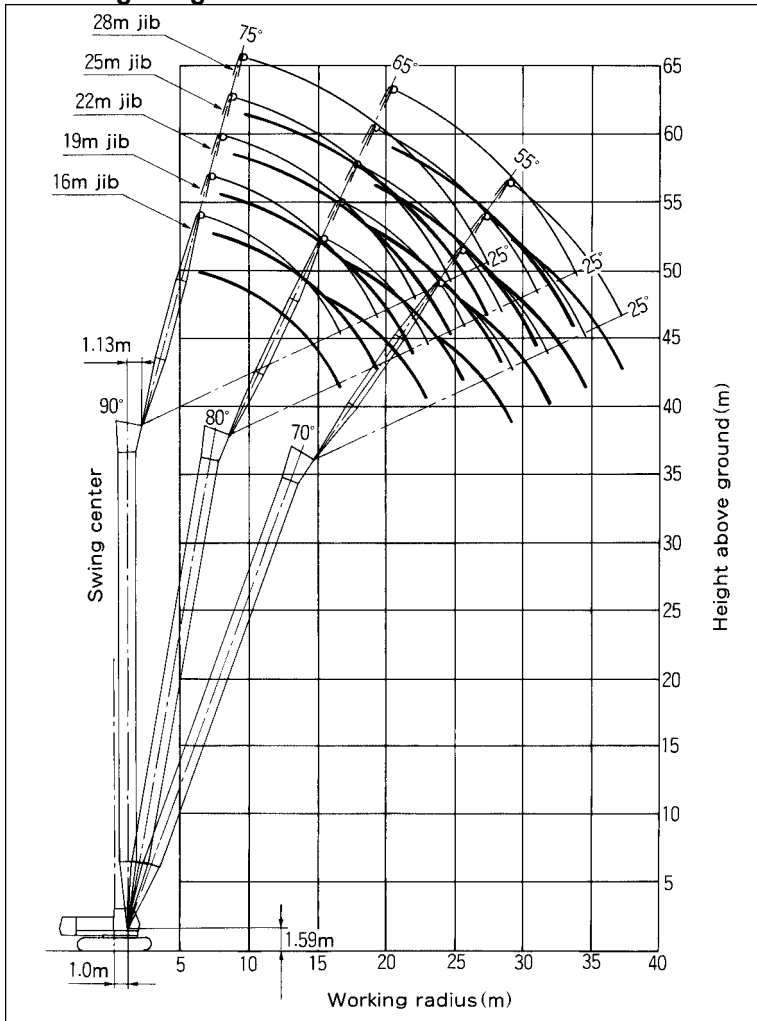

Working ranges are shown for unloading.

40 m Tower (2-Rope Reeving)

Rated Loads for Tower Crane

Unit: t

Working radius (m)	Jib length (m)										
	16m			19m			22m			25m	
	90°	80°	70°	90°	80°	70°	90°	80°	70°	90°	80°
8.7	8.60										
9.0	8.60			9.6×7.80			10.5×7.20				
10.0	8.40			7.80			11.0×7.10			11.5×6.50	
12.0	8.05			7.45			6.90			6.45	
14.0	7.75			15.2×6.95			6.50			6.10	
16.0	6.60	3.95		6.60	17.3×3.55		16.7×6.15			5.75	
18.0	16.7×6.30	3.95		5.70	3.55		5.60	18.5×3.20		18.2×5.50	19.8×2.90
20.0		3.50		19.4×5.20	3.45		5.00	3.20		4.90	2.90
22.0		3.10			3.05		4.40	3.00		4.40	2.90
24.0		23.6×2.85	25.1×2.05		2.75		22.2×4.35	2.70		3.90	2.65
26.0			2.05		2.50	26.8×1.85		2.45		24.9×3.65	2.40
28.0			1.90		26.4×2.45	1.85		2.20	28.5×1.60		2.15
30.0			1.70			1.65		29.1×2.05	1.60		2.00
32.0			30.3×1.70			1.55			1.45		31.8×1.80
34.0						33.1×1.45			1.35		
35.8									1.25		

For notes, refer to those on the 22 m tower.

Working Ranges

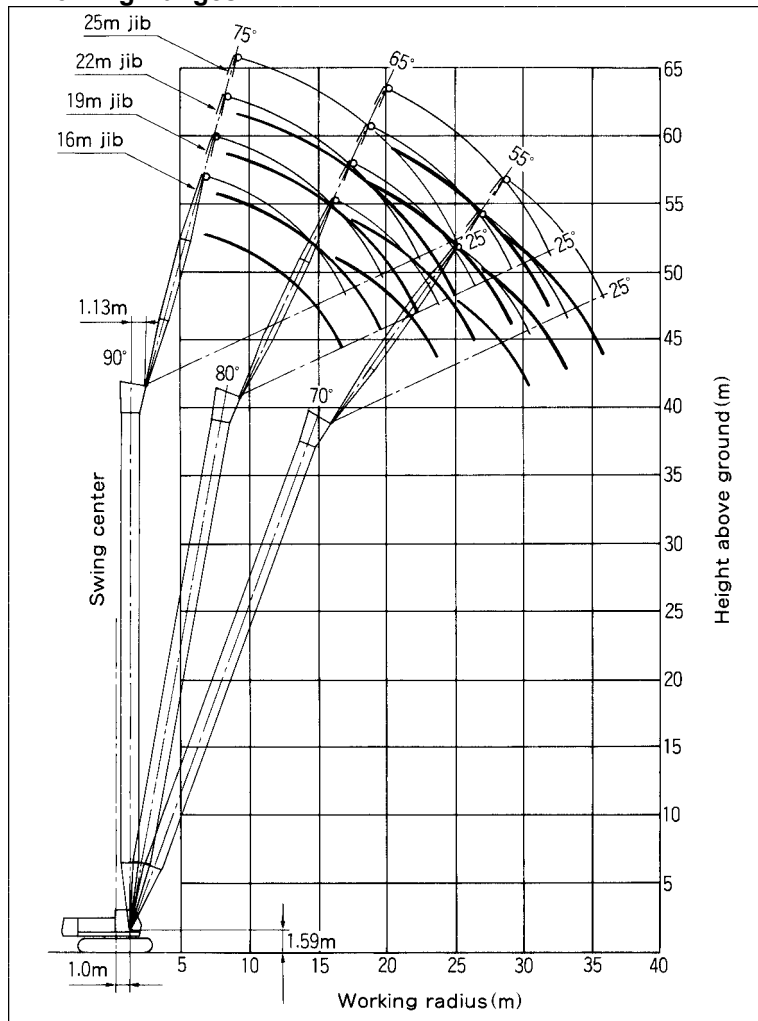

Working ranges are shown for unloading.

■Dimensions

Unit: mm

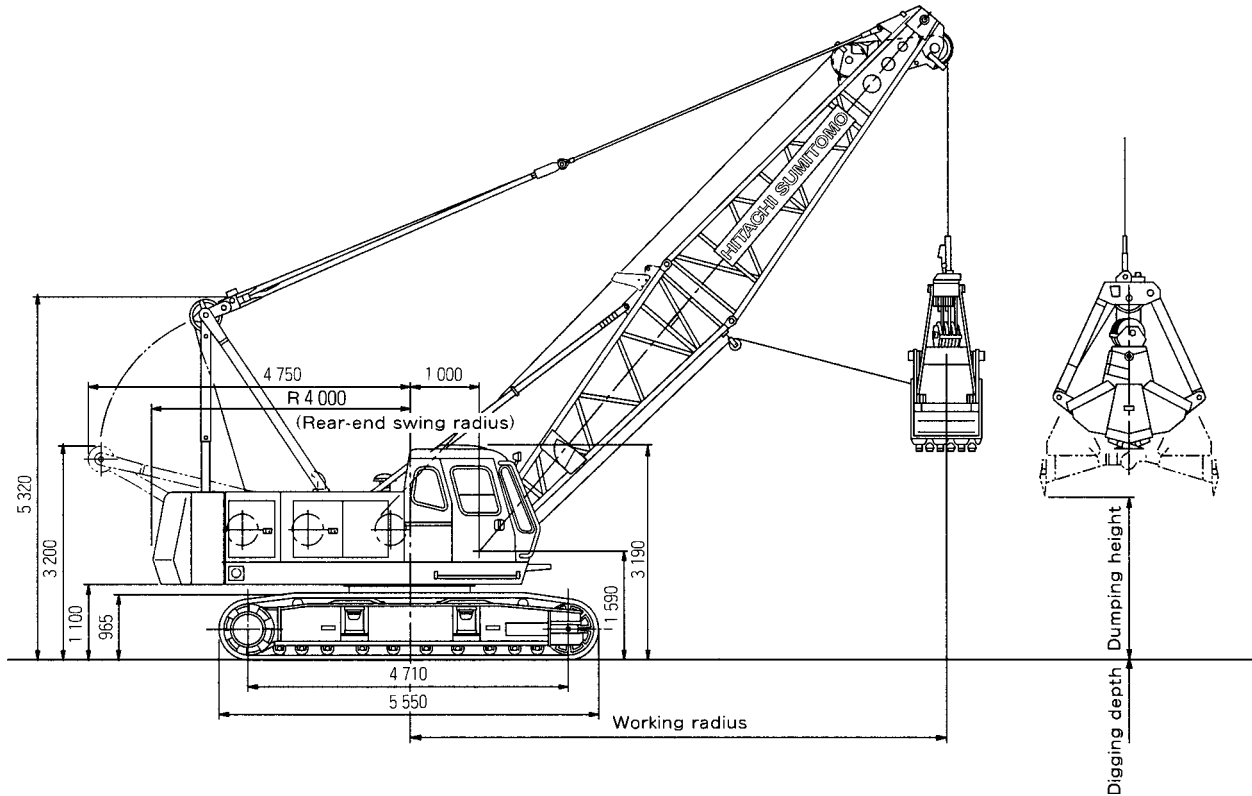

■Specifications

Bucket capacity	m ³	0.8/1.0/1.2
Allowable clamshell gross weight	t	6.0
Boom length	m	10 to 19
Max. digging depth	m	36
Suspend line speeds	m/min	*74/37
Open/close line speeds	m/min	*74/37
Boom hoist/ lower line speed	m/min	*60
Travel speeds	km/h	2.0/1.5
Ground pressure	kPa (kgf/cm ²)	66.7 (0.68)
Operating weight	t	51.8 (10 m boom + 1.2 m ³ bucket)

■Clamshell Bucket

Capacity (m ³)	Weight (t)	Use
0.8	2.00	Excavation
1.0	2.45	Excavation
1.2	3.10	Excavation
1.2	2.40	Light service

Notes: 1. Data is expressed in SI units, followed by conventional units in ().

2. Other specifications, not shown, are similar to those for the crane.

*Line speeds will vary with the load.

■Working Ranges

Boom length	m	10				13				16				19				
		35	45	55	65	35	45	55	65	35	45	55	65	35	45	55	65	
Boom angle	degree																	
Working radius	m	9.4	8.3	7.0	5.6	11.8	10.4	8.7	6.8	14.3	12.6	10.5	8.1	16.8	14.7	12.2	9.4	
Rated load	t	6.00	6.00	6.00	6.00	6.00	6.00	6.00	6.00	6.00	6.00	6.00	6.00	5.8	6.00	6.00	6.00	
Bucket dumping height	m																	
0.8 m ³ bucket		2.0	3.3	4.5	5.4	3.7	5.5	7.0	8.1	5.4	7.6	9.4	10.8	7.1	9.7	11.9	13.6	
1.0 m ³ bucket		1.8	3.1	4.3	5.2	3.5	5.3	6.8	7.9	5.2	7.4	9.2	10.6	6.6	9.5	11.7	13.4	
1.2 m ³ bucket	m	1.6	2.9	4.1	5.0	3.3	5.1	6.6	7.7	5.0	7.2	9.0	10.4	6.7	9.3	11.5	13.2	

Notes: 1. Rated loads for clamshell do not exceed 90% those for crane.

2. The rated loads shown are upper limits determined by the following equation. Please select a bucket in such a manner that its rated load does not exceed the rated load shown below, according to kinds of the loads handled.

$$\text{Rated load} = \text{Bucket capacity (m}^3\text{)} \times \text{Specific gravity of load (t/m}^3\text{)} + \text{Bucket weight (t)}$$

Be careful that brake will be overheated if the bucket is too heavy even within the rated loads.

3. Working radius is the horizontal distance from the swing center to the center of gravity of lifted load.

4. The bucket weight is 3.1 t. (Max)

5. The counterweight is 16.9 t.

6. Be sure to fully extend the side frames before operating the machine.

7. Free fall using brake will vary with operating conditions such as bucket weight and work cycle, but its height should be within 10 m.

■Dimensions

Unit: mm

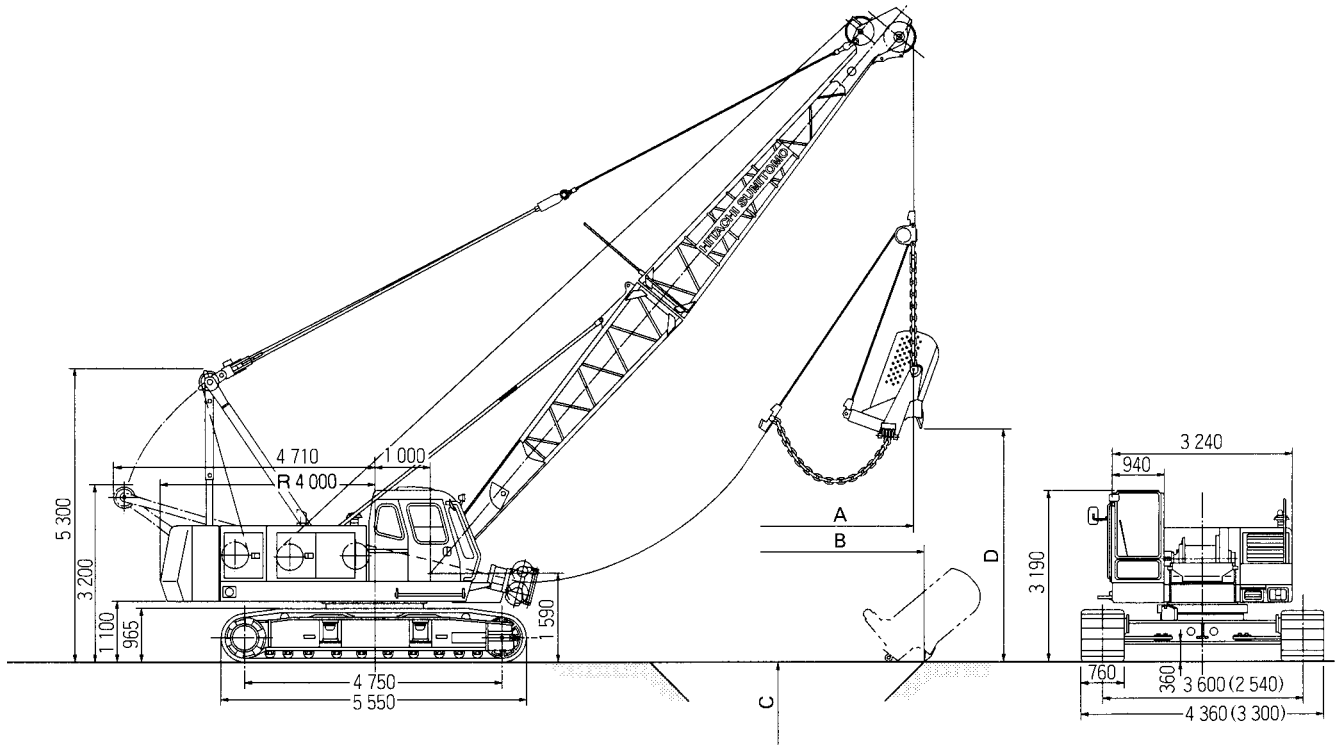

■Specifications

Bucket capacity	m ³	1.15/1.7
Max. bare line pull (1st drum layer)	t	15.6
Boom length	m	13 to 22
Suspend line speeds	m/min	*74/37 Rope 22 mm dia.
Drag line speeds	m/min	*74/37 Rope 22 mm dia.
Boom hoist/lower line speed	m/min	*60 Rope 16 mm dia.
Travel speeds	km/h	2.0/1.5
Swing seeds	min ⁻¹ (rpm)	3.7 (3.7)
Ground pressure	kPa (kgf/cm ²)	60.8 (0.62)
Operating weight	t	50.1 (13 m boom + 1.15 m ³ bucket)

■Dragline Bucket (Reference data)

Capacity (m ³)	Weight (t)	Use
1.15	1.28	Heavy duty
1.7	1.68	Medium service

- Notes: 1. Data is expressed in SI units, followed by conventional units in ().
 2. Other specifications, not shown, are similar to those for the crane.
 3. *Line speeds will vary with the load.

■Working Ranges

Boom length	m	13			16			19			22		
		30	40	50	30	40	50	30	40	50	30	40	50
A Working radius	m	12.8	11.5	9.9	15.4	13.8	11.9	18.0	16.1	13.8	20.6	18.4	15.7
Rated load	t	8.72	9.66	10.82	7.31	8.27	9.41	5.50	6.74	8.21	4.76	5.64	6.95
B Max. digging reach	m	16.3	15.9	15.0	19.6	19.1	18.0	22.9	22.2	21.0	26.2	25.4	23.9
C Max. digging depth	m	8.4	8.1	7.4	10.9	10.5	9.7	13.3	12.8	11.9	15.8	15.2	14.1
D Boom point height	m	7.8	9.7	11.3	9.3	11.3	13.6	10.8	13.5	15.9	12.3	15.5	18.2

- Notes: 1. The size of the bucket has to be determined according to local condition.
 2. The rated loads shown are upper limits determined by the following equation. Please select a bucket in such a manner that its rated load does not exceed the rated load shown above, according to kinds of the loads handled.
 Rated load = Bucket capacity (m³) × Specific gravity of load (t/m³) + Bucket weight (t)
 Be careful that brake will be overheated if the bucket is too heavy even within the rated loads.
 3. Working radius is the horizontal distance from the swing center to the center of gravity of lifted load.
 4. Maximum digging reach/depth may vary considerable depending on digging condition and the skill of the operator.
 5. The counterweight is 16.9 t.
 6. Be sure to fully extend the side frames before operating the machine.

■ STANDARD EQUIPMENT

BASIC MACHINE

Undercarriage

- Crawler-type undercarriage (with 760 mm shoes)
- Side frame extend cylinder (1 pc)

Superstructure

- Front lights (2 pcs)
- Rearview mirrors (left and right)
- Hoist drum check mirror
- Centralized lubrication system (for gantry and swing circle)
- Electric refuel device
- Under-cover (at superstructure bottom)
- Cab climbing steps
- Ultra slow speed controller
- Drum rotation sensing system
- 16.9 t counterweight
- Standard tool kit

Cab

- Intermittent-wipers (front and roof window)
- Washers (front and roof window)
- Rolled sunshade (roof window)
- Sunvisor
- Floor mat
- Room light
- Cigarette lighter
- Ashtray
- Auto-tuning clock radio (AM/FM)
- Brake mode selector switch (interlocked)
- Work mode selector (interlocked)
- Electric tilt-type right side stand

Safety Devices

- Swing lock
- Drum pawl lock (main and auxiliary hoist, and boom hoist)
- Swing alarm
- Fail safe brake system
- Pilot control shut-off lever
- Before-work check monitor

FRONT ATTACHMENTS

Crane

- 10 m basic boom (lower 5 m, upper 5 m)
- Boom back stop
- Boom angle indicator
- 50 t hook
- Main hoist rope ($\phi 22$ mm \times 185 m)
- Boom hoist rope ($\phi 16$ mm \times 135 m)
- Moment limiter
- Overhoist prevention devices (main hook, boom hoist, secondary)

Full-Luffing Tower Crane

- 40 m tower boom (lower: 5 m, 1.5 m \times 2, 3 m \times 1, 6 m \times 3, 9 m \times 1, upper: 2 m) (Up to 25 m tower jib is available to maximum 40 m tower.)
- 28 m tower jib (lower: 5 m, 3 m \times 2, 6 m \times 2, upper: 5 m)
- Tower stop
- Tower boom angle indicator
- 15 t hook
- Main hoist rope ($\phi 22$ mm \times 215 m)
- Tower jib hoist rope (22 mm \times 145 m)
- Tower hoist rope ($\phi 16$ mm \times 150 m)
- Moment limiter
- Overhoist prevention devices (hook, tower, tower jib and secondary)
- Blocks for assembling 31 m or higher tower

Clamshell

- 10 m basic boom (lower 5 m, upper 5 m)
 - Boom stop
 - Boom angle indicator
 - Open/close and suspend rope disengagement prevention device (for tubular chord boom)
 - Open/close rope ($\phi 22$ mm \times 67 m)*
 - Suspend rope ($\phi 22$ mm \times 60 m)*
 - Hydraulic tagline (with $\phi 10$ mm \times 45 m rope)
 - Boom hoist rope ($\phi 16$ mm \times 135 m)
- * Open/close and suspend ropes are determined based on 19 m boom length and 12 m digging depth.

Lifting Magnet

- 13m angle chord boom [Lower 6.5 m, upper 6.5 m, wide-angle sheave (with 2 boom-point sheaves)]
- Boom stop
- Boom angle indicator
- 50 t hook (with hook lock)
- Hoist rope ($\phi 22$ mm \times 185 m)
- Boom hoist rope ($\phi 16$ mm \times 150 m)
- Hoist rope disengagement prevention device (for angle chord boom)
- Hydraulic tagline (with $\phi 10$ mm \times 45 m rope)
- Moment limiter
- Overhoist prevention device (hook, boom hoist, secondary)

Dragline

- 13 m angle chord boom [Lower 6.5 m, upper 6.5 m, wide-angle sheave (with 1 boom-point sheave)]
- Boom stop
- Boom angle indicator
- Hoist rope ($\phi 22$ mm \times 50 m)
- Drag rope ($\phi 22$ mm \times 34 m)
- Boom hoist rope ($\phi 16$ mm \times 150 m)
- Fair-lead
- Overhoist prevention device (Boom hoist, secondary)

■ Standard and Optional Equipment

○ : Standard ● : Option — : Not recommended

	CRAWLWER CRANE	FULL-LUFFING TOWER CRANE	CLAMSHELL	LIFTING MAGNET	DRAGLINE
Superstructure					
3rd drum (free fall type, excluding rope)	●	—	—	—	—
3rd drum rope (φ20 mm × 130 m)	●	—	—	—	—
Drum cooler (for aux. drum)	—	—	●	●	—
Side walk (folded type)	●	●	●	●	●
Side walk (fixed type with handrails)	●	●	●	●	●
Fuel double element	●	●	●	●	●
Engine air cleaner double element	●	●	●	●	●
Cab					
AM/FM radio	○	○	○	○	○
Fan	●	●	●	●	●
Loudspeaker	●	●	●	●	●
Heater	●	●	●	●	●
Air conditioner	●	●	●	●	●
Safety devices					
Foam type level (in cab)	●	●	●	●	●
Bucket overhoist prevention device	—	—	●	—	—
Front attachments for crane and tower crane					
50 t hook (8-rope reevings)	○	●*1	—	○*4	—
30 t hook (5-rope reevings)	●	●*2	—	●*4	—
15 t hook (3-rope reevings)	●	○	—	●*5	—
6.5 t hook	●	●	—	—	—
3 m boom insert	●	○	●	—	—
6 m boom insert	●	○	●	—	—
3 m angle chord boom insert	—	—	—	●	●
6 m angle chord boom insert	—	—	—	●	●
9 m boom insert	●	●	●	—	—
9 m (B) boom insert (for use with jib)	●	○	—	—	—
6 m jib assembly (6 m basic jib, aux. Jib hook overhoist prevention device, jib mast aux. Jib rope (φ22 mm × 120 m), 6.5 t hook)	●	●*2	—	—	—
3 m jib insert	●	●*2	—	—	—
Aux. Jib assembly (aux. Jib, aux. Jib hook overhoist prevention device, aux. Jib rope (φ22 mm × 120 m), 6.5 t hook)	●	●*2	—	—	—
Aux. Jib (aux. jib, aux. jib hook over hoist prevention device)	●	●*2,*3	—	—	—
Crane kit (5 m upper boom, 50 t hook, boom stop, main hoist hook overhoist prevention device)	—	●	—	—	—
Front attachment for other					
0.8 m ³ clamshell bucket	—	—	●	—	—
1.0 m ³ clamshell bucket	—	—	●	—	—
1.2 m ³ clamshell bucket	—	—	●	—	—
1.2 m ³ clamshell bucket (light-service)	—	—	●	—	—
Hydraulic tagline	●	—	○	○	—
Open/close and suspend rope	—	—	○	—	—
1.15 m ³ Dragline bucket	—	—	—	—	●
Fair-lead	—	—	—	—	○
φ1 800 mm lifting magnet assembly	—	—	—	●	—
φ1 500 mm lifting magnet assembly	—	—	—	●	—

Notes: *1. Included in crane kit.

*2. Designed for use with crane kit

*3. When purchased together with jib assembly, these component, excluding common parts such as hook and wire rope, are added

*4. With hook lock

*5. Wide-angle quenched sheave with hook lock

