



ATF-1000XL

100 Ton Capacity (90.7 Metric Tons)

ALL TERRAIN CRANE

DIMENSIONS

() : mm

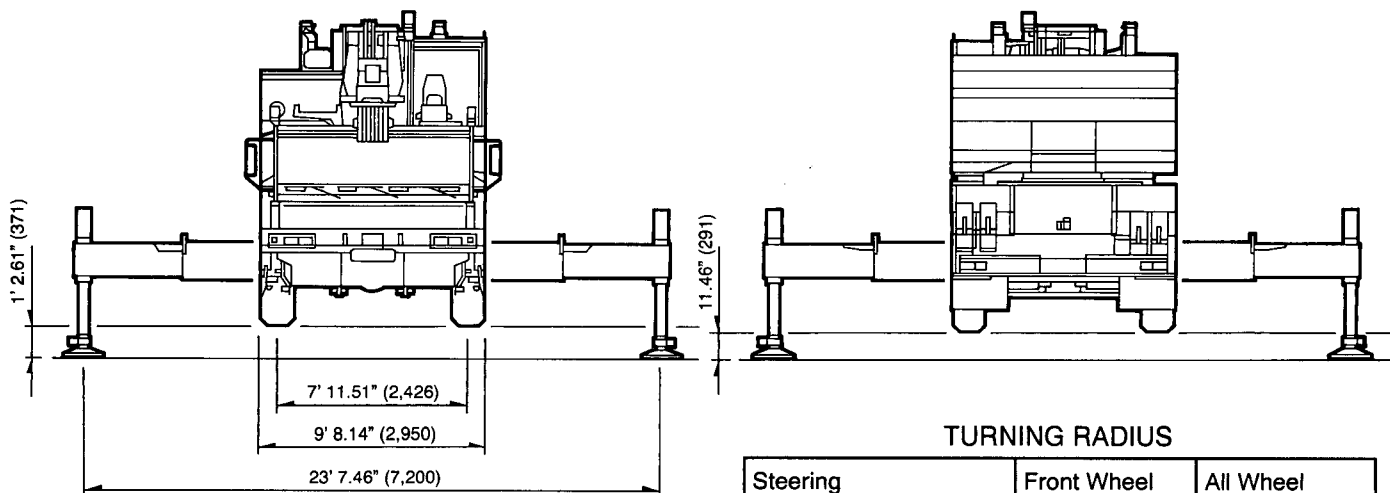
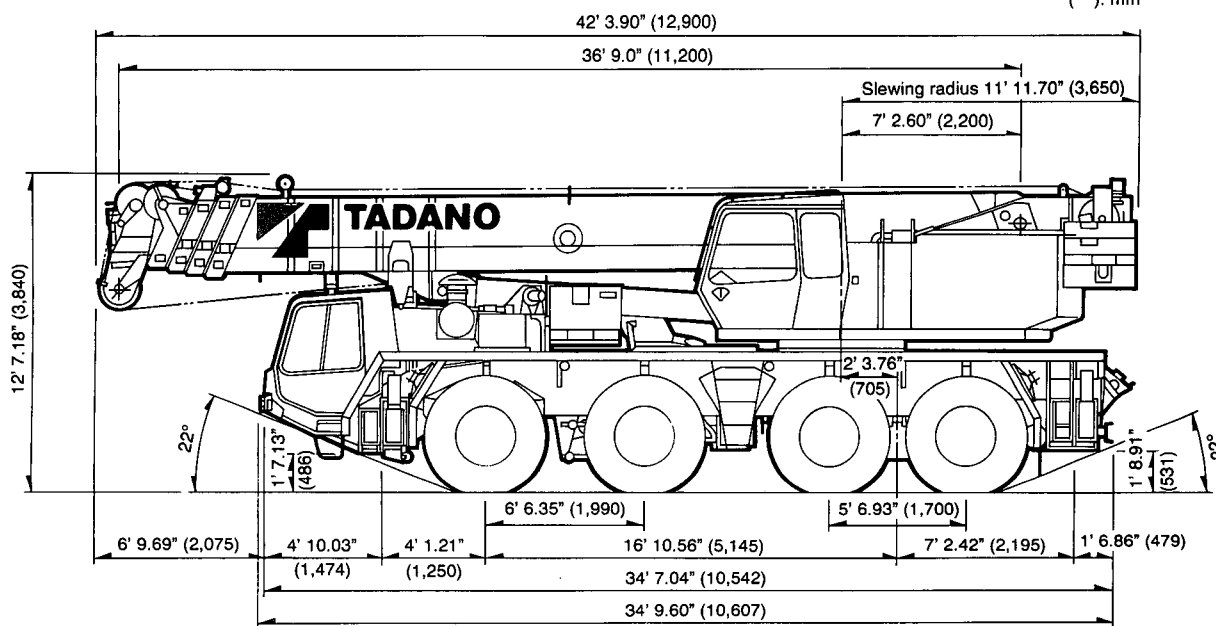

TURNING RADIUS

Steering	Front Wheel	All Wheel
Inside	22.3 ft (6.8m)	14.4 ft (4.4m)
Carrier	40.7 ft (12.4m)	30.7 ft (9.35m)
Over boom extension	44.6 ft (13.6m)	35.8 ft (10.9m)

Specifications are subject to change without notice.

1. CRANE CARRIER

1.1 FRAME

The chassis frame is a torsion and bend resistant rigid box type welded steel structure made of high tensile steel. A support ring with tapped holes is integrated in the upper plate for mounting the ball bearing slewing ring. Double box type outrigger casings are integrated at the front and rear.

1.2 OUTRIGGERS

Four point, fully hydraulic, double telescopic outriggers with horizontal and vertical motions controlled by electromagnetic valves. Push button controls with level gauges are located in the crane cab and on both sides of the carrier. Vertical cylinders are equipped with integral holding valves. Metallic outrigger floats can be stored on either the vertical cylinders or the carrier for road travel.

Outrigger base: Width: 23.62 ft (full extension) or 16.40 ft (half extension)
Length: 28.18 ft

1.3 CARRIER ENGINE

Mercedes Benz model OM 402 LA, 8 cylinder, turbocharged, water cooled diesel engine with intercooler. Displacement 778.8 in³.

Rating: 375 hp at 2,100 rpm.
1,254 ft lbs torque at 1,000-1,500 rpm
(according to 80/1269/EEC and 88/195/EEC).

1.4 COOLING SYSTEM

Water cooling system with hydrostatic driven radiator fan and thermostatically controlled cooler.

1.5 TRANSMISSION

ZF model 6 WG 250 6 speed Powershift transmission with additional crawler gear and hydrodynamic torque converter with automatic lock-up in each forward gear. Crawler gear can only be activated when the front axle drive is connected and the crane is stationary.

Gear ratios: Forward 5.350/3.446/2.207/1.421/0.970/0.625
Reverse 5.350
Additional crawler gear: 1.547

1.6 DRIVE

8x4 for on-road travel

8x6 or 8x8 for off-road travel

The axles are driven as follows:

- 1st condition: two rear axles are driven (on road).
- 2nd condition: 1st front axle drive is shifted.
- 3rd condition: 2nd front axle drive is shifted.
- 4th condition: all transversal differential locks are shifted.

1.7 AXLES

1st axle: Drive/steer axle with outer planetary hubs. Reduction: 11.73
2nd axle: Drive/steer axle with outer planetary hubs. Reduction: 11.73
3rd axle: Drive/steer axle with outer planetary hubs. Reduction: 11.73
4th axle: Drive/steer axle with outer planetary hubs. Reduction: 11.73
Transversal Differential Locks in all axles.

1.8 SUSPENSION

Hydropneumatic lockable suspension with leveling adjustment. All axles have trailing and semi-trailing arms. With the leveling adjustment, the chassis can be tilted laterally and longitudinally by push buttons in the carrier cab acting on each individual suspension cylinder.

Cylinder stroke: -4.72 in.
+5.90 in.

1.9 BRAKE SYSTEM

Service brakes: dual circuit compressed air system with air dryer.
Parking brake: spring loaded type acting on 2nd, 3rd and 4th axles.
Auxiliary brake: eddy-current brake (Telma electrical brake) at the 4th axle.
ABS-system (anti-lock brake system).

1.10 WHEELS

(8) disc-wheels 17.00-25 with (8) 20.5 R 25 on/off road profile tire (Bridgestone VHB).

(1) spare disc-wheel 17.00-25 with (1) 20.5 R 25 (Bridgestone VHB) spare tire.

1.11 STEERING SYSTEM

From carrier cab: ZF dual circuit semi-block mechanical steering of the two front axles with hydraulic booster and transmission mounted emergency steering pump. In case of a main pump failure, the emergency steering pump automatically takes over the function of the main pump and is dependent on travel speed. An electrical display in the chassis cab notifies the driver if this occurs. At slow speeds, (1st and 2nd gear only), rear axles can also be hydraulically steered. (Not permitted when towing a dolly). Both rear axles are mechanically locked in "centered" position when rear steering is not activated.

From crane cab: hydrostatic steering of all four axles. Front two axles are controlled by a lever and the rear two axles are controlled by a push button providing all-wheel, coordinated or crab steering modes.

1.12 POWER TRAIN

Maintenance free drive shafts with geared flanges.

1.13 FUEL SYSTEM

105.7 gal. fuel tank.

1.14 CARRIER CAB

Two man full width cab of composite structure (steel sheet metal and fiberglass), windshield of laminated safety glass with windshield wiper and washer, sliding side windows of hardened glass, adjustable spring suspended hydraulically cushioned seats with 3 point safety belts, 2 cab roof ventilation flaps, 2 rear-view mirrors and additional curb mirror (all electrically heated), portable radio/cassette (also for crane cab) and connections for wireless, engine dependent warm water heater w/ defroster nozzles for windshield and cab floor.

Instrumentation includes speedometer, odometer, tachograph, hour meter, tachometer, fuel level gauge, air pressure gauge, oil pressure indicator lamp, engine temperature and transmission temperature indicator lamps and gauges.

1.15 ELECTRICAL SYSTEM AND EQUIPMENT

24 volt DC system with 80 ampere 3-phase alternator, two 12 volt/170 Ah batteries, with remote engine start and battery recharging connections. Front lighting includes: 2 main headlights, 2 high beam headlights, 2 foglights, 2 directional indicator and 2 parking lights. Rear lighting includes: 2 rear panels, each with directional indicator, parking light, brake light, foglight and backup light: plus separate license plate light. Side lighting includes: 2 front directional indicators and reflectors on carrier. Other equipment includes: hazard warning light system, cab light, instrument panel light, signal horn, rotating beacon on cab roof.

1.16 TOOLS AND ACCESSORIES

Include: special tool set, 4 wheel chokes, warning triangle, hazard warning flashing lamp, fire extinguisher, first aid kit.

1.17 PAINTING

Standard TADANO Tricolor.

1.18 DIMENSIONS

Overall width: 9.68 ft
Overall height: 12.6 ft normal
12.2 ft lowered
Overall length: 42.3 ft
Carrier length: 34.8 ft
Wheel base: 6.52 ft+7.56 ft+5.57 ft
Tailswing: 12 ft

1.19 TRAVEL PERFORMANCE (106,000 LBS. GVW)

max. travel speed: 48.5mph
 max. gradeability: 73%
 (Theoretical value - gradeability depends on ground conditions and the coefficient of friction.)
 Acceleration 1 to 31 mph: 36 seconds

1.20 OTHER EQUIPMENT FOR CARRIER

1. Spare wheel and tire 20.5 R 25 (Bridgestone VHB).
2. Central lubricating system.
3. Trailer coupling (Rockinger type 260 G 140) D value 9.5t with double brake line connection, ABS brake system connection and electrical connection for use with boom dolly.
4. Carrier deck plates with anti-slip coating.
5. Front and rear fenders.
6. Front and rear towing and tie-down lugs and hook block retainer
7. Access ladder
8. Hook block storage bracket
9. Hook ball storage bracket

1.21 CARRIER OPTIONAL EQUIPMENT

1. 8x6 drive
2. Engine pre-heat system
3. Hydraulic tank pre-heat system

2. TRAVEL PERFORMANCE DATA (According to DIN 70020)

Travel speeds and gradeabilities for each gear on firm and dry road surface.

2.1 Machine with 20.5 R 25 tires and 106,000 lbs GVW.

Travel speeds (mph):

	normal	crawler gear
1st gear:	5.6	3.7
2nd gear:	8.7	5.6
3rd gear:	13.7	8.7
4th gear:	21.1	13.7
5th gear:	31.1	20.5
6th gear:	48.5	31.7
Reverse gear:	5.6	3.7

Gradeability (%) - (max torque moment)

	normal	crawler gear
1st gear:	40	73*
2nd gear:	24	40
3rd gear:	15	24
4th gear:	9	15
5th gear:	5.5	9.5
6th gear:	3	5.5
Reverse gear:	40	73*

Acceleration 0-31 mph in 36 seconds

*) Theoretical value - gradeability depends on ground conditions and the coefficient of friction.

2.2 Machine with 20.5 R 25 tires and 128,000 lbs GVW.

Travel speeds (mph):

	normal	crawler gear
1st gear:	5.6	3.7
2nd gear:	8.7	5.6
3rd gear:	13.7	8.7
4th gear:	21.1	13.7
5th gear:	31.1	20.5
6th gear:	48.5	31.7
Reverse gear:	5.6	3.7

Gradeability (%) - (max torque moment)

	normal	crawler gear
1st gear:	32	56*
2nd gear:	20	32
3rd gear:	12	20
4th gear:	7	12
5th gear:	4.5	7.5
6th gear:	2	4
Reverse gear:	32	56*

*) Theoretical value - gradeability depends on ground conditions and the coefficient of friction.

3. CRANE SUPERSTRUCTURE

3.1 FRAME

Torsion resistant all welded rigid structure of high strength steel. Connected to carrier by single row ball bearing slewing ring with internal gearing for 360° continuous rotation.

3.2 CRANE ENGINE

Mercedes Benz model OM 366A 6 cylinder, water cooled diesel engine, rated at 158.2 hp at 2,300 rpm (according to DIN 6270B). Foot pedal and hand lever throttle controls.

Separate fuel tank - 52.83 gal.

3.3 HYDRAULIC SYSTEM

Three circuit hydraulic system with 1 double axial piston variable displacement pump (hydraulically adjustable with cross-sensing) and 1 double gear pump for swing and pilot controls.

3.4 HYDRAULIC CONTROLS

2 joystick and 1 single axis self centering, pilot controlled levers plus 5 three-way hydraulically operated valves for independent simultaneous operation of all crane motions with variable speed control.

3.5 TELESCOPIC MAIN BOOM

Five section hexagonal box type construction of high tensile, fine-grained steel consisting of 1 base section and 4 full power telescoping sections. The boom is extended by means of 3 double acting hydraulic cylinders with integral holding valves and a rope crowd extension system. Boom head contains 2 idler sheaves and 7 load bearing sheaves made of nylatron. Equipped with anti-two block system.

Total retracted length: 36.75 ft

Total extended length: 138.12 ft

Maximum sheave height: 146.00 ft

Telescope speed: normal 180 seconds/high 90 seconds

Two telescoping modes:

- a) telescopic sections 1+2 synchronously to full extension then 3+4 synchronously
- b) all telescopic section (1+2+3+4) synchronously

For service purposes it is possible to telescope sections 1, 2 and 3 independently.

3.6 TELESCOPIC BOOM EXTENSION

Swing around telescopic boom extension 29.53 ft - 52.5 ft long, offset 5°/17°/30°, consisting of a 29.53 ft long lattice type base section and a 23 ft long box type extension which stores inside the base section. Equipped with additional anti-two block system.

3.7 AUXILIARY LIFTING SHEAVE (SINGLE TOP)

Single sheave mounted to main boom head for single line operation (stowable).

3.8 BOOM HOIST

1 double acting hydraulic cylinder with integral holding valve.

Boom elevation: minus 2° to +82°.

Boom elevation speeds: normal 92 seconds/high 46 seconds.

3.9 MAIN WINCH

Axial piston constant displacement motor, grooved hoist drum with integral planetary gear and hydraulically controlled spring loaded multiple disc brake, drum rotation indicator, cable follower and lower limit switch.

Drum diameter: 14.17 in

Rope dia./length: 0.71 in×600 ft

Max. line pull: 13,500 lbs at min. layer

Max. line speed: normal 190 ft/min at max. layer
high 377 ft/min at max. layer

3.10 AUXILIARY WINCH

Axial piston constant displacement motor, grooved hoist drum with integral planetary gear and hydraulically controlled spring loaded multiple disc brake, drum rotation indicator, cable follower and lower limit switch.

Drum diameter: 13.98 in

Rope dia./length: 0.63 in×500 ft

Max. line pull: 10,000 lbs at min. layer

Max. line speed: 312 ft/min at max. layer

3.11 SLEWING GEAR

Single ball bearing slewing ring with internal gear driven by constant displacement axial piston motor with 2-stage planetary gear. Foot actuated service brake, plus parking brake

Slewing speed infinitely variable: 0-2.0 rpm continuous through 360°

Reduced speed: 0-1.0 rpm

3.12 COUNTERWEIGHT

Counterweight assembled and disassembled by hydraulic cylinders controlled from crane cab. 29,750 lbs counterweight consisting of 6 pieces:

- | | |
|---------------------------|----------------------------|
| no. 1-4,850 lbs fixed | no. 4-3,090 lbs removable |
| no. 2-1,540 lbs fixed | no. 5-7,050 lbs removable |
| no. 3-1,540 lbs removable | no. 6-11,680 lbs removable |

3.13 CRANE CAB

Spacious all steel comfortable panoramic cab with sliding door and extra-large tinted laminated safety glass windows, swing out front window with windshield wiper, fixed cab roof window with armored glass and wiper, sun visor, cab light, signal horn, radio/cassette housing, connections for wireless, adjustable spring suspended hydraulically cushioned seat and engine-independent hot air heater with defroster nozzles for windshield and cab floor, electric fan. Pressure gauge for crane hydraulic. Central warning lamp for engine, hydraulic filter and hydraulic oil temperature. Fuel level gauge, hydraulic system pressure gauge and hour meter. Ergonomically positioned controls and instrumentation for crane operation and traveling.

3.14 ELECTRICAL SYSTEM

24 volt DC system with 30 ampere 3-phase alternator, two 12 volt/110 Ah batteries, with remote engine start and battery recharging connections, plus 1 rotating beacon on right-hand side of main winch, 2 working lights on cab front flap, 1 working light on boom base section and 2 side lights on boom head.

3.15 SAFETY DEVICES

Load moment device (PAT DS350) with interpolation and automatic overload shut-off. Digital display for boom angle, boom length, working radius, hook load, plus additional information. Anti-two block devices for telescopic main boom, telescopic boom extension and auxiliary lifting sheave. Safety valves against pipe and hose rupture, holding valves on hydraulic cylinders, lower limit switch, drum rotation indicators and drum cable followers on main and auxiliary winch.

3.16 SUPERSTRUCTURE EQUIPMENT

1. 6.6 ton (13,230 lbs) headache ball.
2. 70 ton (140,000 lbs) hook block. (5 sheave ram's head with double hook)
3. Free mechanism in boom elevation and slewing circuits for travel with boom dolly.

3.17 SUPERSTRUCTURE OPTIONAL EQUIPMENT

1. Engine pre-heat system
2. Hydraulic tank pre-heat system
3. 22 ton 1 sheave hook block
4. 44 ton 3 sheave hook block

ATF-1000XL

OPERATING RADIUS/LIFTING HEIGHT CHART

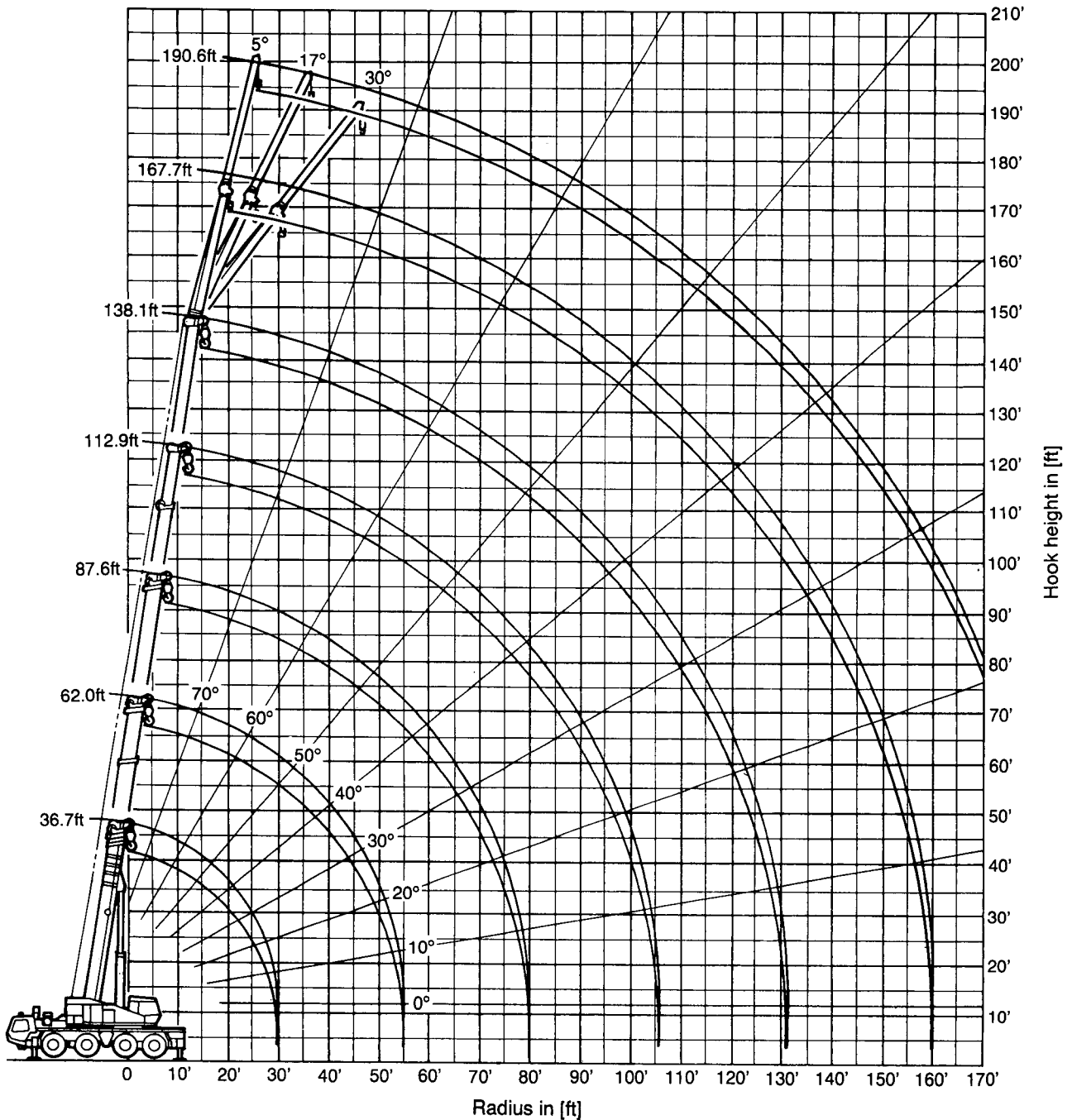

NOTE: Operating Radius is measured in feet from Axis of Rotation. Boom and jib geometry shown are for unloaded condition and machine standing level on firm supporting surface. Boom deflection and subsequent radius and boom angle change must be accounted for when applying load to hook.

ATF-1000XL TADANO-Load rating chart

☐ TELESCOPIC BOOM

- Counterweight 29,760 lbs.

Lifting capacities in 1,000 lbs per SAE J765

Working Radius (ft)	On outriggers, 360° working area Outrigger base 23.62 ft									On outriggers, 360° working area Outrigger base 16.4 ft									Working Radius (ft)
	Boom length (ft)									Boom length (ft)									
	36.75 1)	36.75	62.00	62.00	87.60	87.60	112.87	112.87	138.12	36.75	62.00	62.00	87.60	87.60	112.87	112.87	138.12		
9	200.0*	165.0																9	
10	175.0*	162.8	88.0	36.0	55.0	33.0				141.8	88.1	34.8	55.0	32.9				10	
12	156.7	143.8	88.0	36.0	55.0	33.0				125.4	88.1	34.8	55.0	32.9				12	
14	135.2	131.4	88.0	36.0	55.0	33.0				112.5	88.1	34.8	55.0	32.9	34.8			14	
16	117.7	117.7	88.0	36.0	55.0	33.0	35.0	25.0		101.3	88.1	34.8	55.0	32.9	34.8	25.2		16	
18	103.9	103.9	85.4	36.0	55.0	33.0	35.0	25.0		85.9	78.7	34.8	55.0	32.9	34.8	25.2		18	
20	92.7	92.7	81.6	36.0	54.8	33.0	35.0	25.0	22.0	70.3	67.3	34.8	54.8	32.9	34.8	25.2	21.9	20	
25	72.7	72.7	70.2	36.0	48.4	33.0	35.0	25.0	22.0	46.5	42.1	34.8	45.3	32.9	34.8	25.2	21.9	25	
30			57.6	36.0	40.4	33.0	34.9	25.0	22.0		32.9	34.1	32.1	32.7	34.0	25.0	21.9	30	
35			45.4	36.0	34.6	32.5	31.3	24.7	22.0		25.0	26.9	24.4	28.0	26.6	24.6	21.9	35	
40			35.8	35.8	30.1	29.6	27.0	24.0	21.1		19.7	21.7	19.1	22.4	21.2	22.9	20.5	40	
45			29.2	31.4	26.4	27.0	23.6	21.6	19.0		15.8	18.0	15.3	18.4	17.3	18.7	18.4	45	
50			24.1	26.8	23.2	25.0	21.0	19.5	17.4		12.7	15.0	12.4	15.4	14.4	15.6	15.7	50	
55					19.8	22.7	18.6	18.0	16.0				10.0	12.9	12.0	13.1	13.2	55	
60					16.6	19.9	16.6	16.7	14.7				8.0	10.9	10.0	11.0	11.2	60	
65					14.1	17.2	14.9	15.3	13.7				6.4	9.3	8.3	9.3	9.5	65	
70					11.9	14.9	13.4	14.3	12.6				5.1	7.9	7.0	8.0	8.2	70	
75					9.9	13.1	12.0	13.2	11.5				4.0	6.7	5.9	6.8	7.0	75	
80							10.6	11.7	10.5						4.8	5.8	6.0	80	
85							9.1	10.2	9.5						4.0	4.9	5.1	85	
90							7.8	9.0	8.5						3.1	4.1	4.2	90	
95							6.9	7.9	7.5						2.4	3.5	3.6	95	
100							6.1	7.0	6.8						1.8	2.9	3.0	100	
110									5.7								1.9	110	
120									4.1									120	
Telescoping conditions %																			
Tel. 1	0	50	25	100	50	100	75	100	0	50	25	100	50	100	75	100	Tel. 1		
Tel. 2	0	50	25	100	50	100	75	100	0	50	25	100	50	100	75	100	Tel. 2		
Tel. 3	0	0	25	0	50	50	75	100	0	0	25	0	50	50	75	100	Tel. 3		
Tel. 4	0	0	25	0	50	50	75	100	0	0	25	0	50	50	75	100	Tel. 4		
Code	01/02	01	02	01	02	01	02	01/02	07/08	07	08	07	08	07	08	07/08	Code		

1) Over rear, swing lock engaged

* With additional equipment

Working Radius (ft)	Without outriggers over rear/360°				Working Radius (ft)
	Boom length (ft)				
	36.75		62.00		
	o.rear	360°	o.rear	360°	
10	47.9		34.8		10
12	42.7		34.8		12
14	38.3		34.8		14
16	34.7		34.8		16
18	31.7		32.2		18
20	28.8		29.3		20
25	22.1		22.9		25
30			17.1		30
35			13.0		35
40			10.2		40
45			8.0		45
50			6.3		50
Telescoping conditions %					
Tel. 1	0		25		Tel. 1
Tel. 2	0		25		Tel. 2
Tel. 3	0		25		Tel. 3
Tel. 4	0		25		Tel. 4
Code	20				Code

Operation and Maintenance of this machine must be in compliance with the information provided in the "Operation and Maintenance Manual" supplied with this machine.

• Counterweight 7,940 lbs.

Lifting capacities in 1,000 lbs per SAE J765

Working Radius (ft)	On outriggers, 360° working area Outrigger base 23.62 ft									On outriggers, 360° working area Outrigger base 16.4 ft									Working Radius (ft)
	Boom length (ft)									Boom length (ft)									
	36.75 1)	36.75	62.00	62.00	87.60	87.60	112.87	112.87	138.12	36.75	62.00	62.00	87.60	87.60	112.87	112.87	138.12		
9	200.0*	155.0																	9
10	172.0*	153.5	88.0	36.0	55.0	33.0				153.5	88.0	36.0	55.0	33.0					10
12	141.8	141.4	88.0	36.0	55.0	33.0				141.4	88.0	36.0	55.0	33.0					12
14	120.9	120.9	88.0	36.0	55.0	33.0				109.0	88.0	36.0	55.0	33.0					14
16	105.1	105.1	88.0	36.0	55.0	33.0	35.0	25.0		78.0	76.0	36.0	55.0	33.0	35.0	25.0			16
18	92.4	92.4	85.4	36.0	54.8	33.0	35.0	25.0		60.0	58.5	36.0	55.0	33.0	35.0	25.0			18
20	82.6	82.6	81.4	36.0	54.8	33.0	35.0	25.0	22.0	48.5	46.5	36.0	46.0	33.0	35.0	25.0	22.0		20
25	60.0	60.0	59.3	36.0	48.3	33.0	35.0	25.0	22.0	31.0	29.5	32.5	29.0	33.0	32.0	25.0	22.0		25
30			41.5	36.0	40.1	33.0	34.9	25.0	22.0		20.5	23.0	20.0	23.8	22.8	24.0	22.0		30
35			31.1	33.4	29.9	32.5	31.3	24.7	22.0		14.5	17.0	14.0	17.8	16.8	18.0	18.0		35
40			24.1	26.5	23.1	26.3	25.7	24.0	21.1		10.5	13.0	10.5	13.7	12.8	13.8	13.9		40
45			19.0	21.5	18.4	21.4	20.6	21.6	19.0		8.0	9.8	7.5	10.7	9.8	10.8	10.9		45
50			15.2	17.5	14.4	17.7	16.6	18.3	17.4		6.0	7.5	5.0	8.0	7.3	8.6	8.7		50
55					11.3	14.6	13.4	15.0	15.5				3.7	6.5	5.7	6.8	6.8		55
60					9.0	12.1	11.0	12.5	12.7				2.0	5.0	4.0	5.0	5.0		60
65					7.0	10.1	9.2	10.3	10.5				1.0	3.9	2.8	4.0	4.0		65
70					5.4	8.3	7.6	8.5	8.9						2.0	3.0	3.0		70
75					4.1	7.0	6.2	7.2	7.5						1.0	2.0	2.0		75
80							4.9	6.1	6.3										80
85							3.8	5.1	5.3									1.6	85
90							3.1	4.0	4.3									0.9	90
95							2.3	3.3	3.5										95
100								2.9	2.8										100
Telescoping conditions %																			
Tel. 1	0	50	25	100	50	100	75	100	0	50	25	100	50	100	75	100			Tel. 1
Tel. 2	0	50	25	100	50	100	75	100	0	50	25	100	50	100	75	100			Tel. 2
Tel. 3	0	0	25	0	50	50	75	100	0	0	25	0	50	50	75	100			Tel. 3
Tel. 4	0	0	25	0	50	50	75	100	0	0	25	0	50	50	75	100			Tel. 4
Code	05/06	05	06	05	06	05	06	05/06	11/12	11	12	11	12	11	12	11/12			Code

1) Over rear, swing lock engaged

* With additional equipment

Working Radius (ft)	Without outriggers over rear/360°				Working Radius (ft)
	Boom length (ft)				
	36.75		62.00		
	o.rear	360°	o.rear	360°	
10	47.9		34.8		10
12	42.7		34.8		12
14	35.0		33.5		14
16	28.5		27.0		16
18	23.5		22.3		18
20	19.8		18.7		20
25	13.3		12.2		25
30			8.2		30
35			5.3		35
40			3.3		40
45			1.7		45
Telescoping conditions %					
Tel. 1	0		25		Tel. 1
Tel. 2	0		25		Tel. 2
Tel. 3	0		25		Tel. 3
Tel. 4	0		25		Tel. 4
Code		22			Code

Operation and Maintenance of this machine must be in compliance with the information provided in the "Operation and Maintenance Manual" supplied with this machine.

EXTENDIBLE FLY JIB

- Counterweight 29,760 lbs.

Lifting capacities in 1,000 lbs per SAE J765

Working Radius (ft)	On outriggers, 360° working area Outrigger base 23.62 ft												On outriggers, 360° working area Outrigger base 16.4 ft												Working Radius (ft)				
	Boom length												Boom length																
	36.75 ft to 127.95 ft						127.95 ft to 138.12 ft						36.75 ft to 127.95 ft						127.95 ft to 138.12 ft										
	Extendible fly jib 29.53 ft offset						Extendible fly jib 52.50 ft offset						Extendible fly jib 29.53 ft offset						Extendible fly jib 52.50 ft offset										
	4°	5°	17°	30°	4°	5°	17°	30°	4°	5°	17°	30°	4°	5°	17°	30°	4°	5°	17°	30°	4°	5°	17°	30°					
30	80	13.2	80	11.0									80	13.2	80	11.0									30				
35	78	12.9	79	11.0	81	9.5							78	12.9	79	11.0	81	9.5							35				
40	76	12.4	77	10.7	79	8.6	81	6.5	79	6.5			76	12.4	77	10.7	79	8.6	81	6.5	79	6.5			40				
45	73	11.9	74	9.7	76	7.8	78	6.5	77	6.4			73	11.9	74	9.7	76	7.8	78	6.5	77	6.4			45				
50	72	11.4	73	8.7	75	7.1	77	6.1	76	6.1	79	4.0		72	11.4	73	8.7	75	7.1	77	6.1	76	6.1	79	4.0	50			
55	69	10.7	71	7.8	73	6.5	75	5.6	74	5.7	77	3.8	80	2.5	69	10.7	71	7.8	73	6.5	75	5.6	74	5.7	77	3.8	80	2.5	55
60	68	9.8	70	7.1	72	5.9	74	5.2	73	5.1	76	3.5	79	2.5	68	9.8	70	7.1	72	5.9	74	5.2	73	5.1	76	3.5	79	2.5	60
65	66	9.0	67	6.4	69	5.5	71	4.8	71	4.6	74	3.3	77	2.5	66	9.0	67	6.4	69	5.5	71	4.8	71	4.6	74	3.3	77	2.5	65
70	64	8.3	66	5.8	68	5.1	69	4.5	69	4.4	73	3.1	76	2.4	64	8.3	66	5.8	68	5.1	69	4.5	69	4.4	73	3.1	76	2.4	70
75	62	7.7	64	5.3	66	4.7	68	4.2	68	4.1	70	3.0	73	2.3	62	7.4	64	5.3	66	4.7	68	4.2	68	4.1	70	3.0	73	2.3	75
80	60	7.1	62	4.9	64	4.3	66	3.9	66	3.7	69	2.9	72	2.3	60	6.4	62	4.9	64	4.3	66	3.9	66	3.7	69	2.9	72	2.3	80
85	57	6.6	60	4.5	61	4.0	63	3.6	64	3.5	67	2.8	70	2.3	57	5.4	60	4.5	61	4.0	63	3.6	64	3.5	67	2.8	70	2.3	85
90	55	6.1	58	4.2	60	3.7	61	3.3	63	3.2	66	2.7	69	2.2	55	4.6	58	4.2	60	3.7	61	3.3	63	3.2	66	2.7	69	2.2	90
95	53	5.8	56	3.8	58	3.4	59	3.1	61	3.0	64	2.6	67	2.1	53	3.8	56	3.8	58	3.4	59	3.1	61	3.0	64	2.6	67	2.1	95
100	51	5.5	54	3.5	56	3.2	58	3.0	59	2.7	63	2.4	65	2.0	51	3.1	54	3.4	56	3.2	58	3.0	59	2.7	63	2.4	65	2.0	100
110	45	4.6	49	3.0	51	2.8	52	2.7	56	2.3	59	2.1	61	1.9	45	2.0	49	2.2	51	2.5	52	2.7	56	2.3	59	2.1	61	1.9	110
120	39	3.5	44	2.7	46	2.4	47	2.3	51	2.0	54	1.9	57	1.8	39	1.0	44	1.4	46	1.5	47	1.6	51	2.0	54	1.9	57	1.8	120
130	33	2.3	39	2.3	40	2.1	42	2.1	48	1.7	51	1.6	53	1.5			39	0.6	40	0.7	42	0.7	48	1.5	51	1.6	53	1.5	130
140	24	1.4	32	1.9	33	1.9	34	1.8	42	1.5	45	1.3	47	1.3									42	0.8	45	1.1	47	1.3	140
150			24	1.0	25	1.1	26	1.2	38	1.3	41	1.2	43	1.2									38	0.4	41	0.6	43	0.7	150
160									32	1.1	34	1.0	36	1.0															160
170									26	0.9	28	0.9	29	0.9															170
Telescoping conditions %																													
Tel. 1	100													100													Tel. 1		
Tel. 2	100													100													Tel. 2		
Tel. 3	80													80													Tel. 3		
Tel. 4	80													80													Tel. 4		
Code	50		52		54		70		72		74		60		62		64		80		82		84		Code				

Main Winch Line Pull is 13,500 lbs and Aux.
Winch Line Pull is 10,000 lbs
To attain lift capacities in excess of 10,000 lbs with single part line Main Winch must be used.

Operation and Maintenance of this machine must be in compliance with the information provided in the "Operation and Maintenance Manual" supplied with this machine.

- Counterweight 7,940 lbs.

Lifting capacities in 1,000 lbs per SAE J765

Working Radius (ft)	On outriggers, 360° working area Outrigger base 23.62 ft												On outriggers, 360° working area Outrigger base 16.4 ft												Working Radius (ft)							
	Boom length												Boom length																			
	36.75 ft to 127.95 ft						127.95 ft to 138.12 ft						36.75 ft to 127.95 ft						127.95 ft to 138.12 ft													
	Extendible fly jib 29.53 ft offset						Extendible fly jib 52.50 ft offset						Extendible fly jib 29.53 ft offset						Extendible fly jib 52.50 ft offset													
	4°	5°	4°	5°	17°	30°	4°	5°	17°	30°	4°	5°	4°	5°	17°	30°	4°	5°	4°	5°	17°	30°	4°	5°	4°	5°	17°	30°				
30	80	13.2	80	11.0														80	13.2	80	11.0									30		
35	78	12.9	79	11.0	81	9.5												78	12.9	79	11.0	81	9.5							35		
40	76	12.4	77	10.7	79	8.6	81	6.5	79	6.5								76	12.4	77	10.7	79	8.6	81	6.5	79	6.5			40		
45	73	11.9	74	9.7	76	7.8	78	6.5	77	6.4								73	11.9	74	9.7	76	7.8	78	6.5	77	6.4			45		
50	72	11.4	73	8.7	75	7.1	77	6.1	76	6.1	79	4.0						72	11.4	73	8.7	75	7.1	77	6.1	76	6.1	79	4.0	50		
55	69	10.7	71	7.8	73	6.5	75	5.6	74	5.7	77	3.8	80	2.5				69	10.7	71	7.8	73	6.5	75	5.6	74	5.7	77	3.8	80	2.5	55
60	68	9.8	70	7.1	72	5.9	74	5.2	73	5.1	76	3.5	79	2.5				68	9.8	70	7.1	72	5.9	74	5.2	73	5.1	76	3.5	79	2.5	60
65	66	9.0	67	6.4	69	5.5	71	4.8	71	4.6	74	3.3	77	2.5				66	9.0	67	6.4	69	5.5	71	4.8	71	4.6	74	3.3	77	2.5	65
70	64	8.0	66	5.8	68	5.1	69	4.5	69	4.4	73	3.1	76	2.4				64	8.0	66	5.8	68	5.1	69	4.5	69	4.4	73	3.1	76	2.4	70
75	62	6.8	64	5.3	66	4.7	68	4.2	68	4.1	70	3.0	73	2.3				62	6.8	64	5.3	66	4.7	68	4.2	68	4.1	70	3.0	73	2.3	75
80	60	5.5	62	4.9	64	4.3	66	3.9	66	3.7	69	2.9	72	2.3				60	5.5	62	4.9	64	4.3	66	3.9	66	3.7	69	2.9	72	2.3	80
85	57	4.5	60	4.5	61	4.0	63	3.6	64	3.5	67	2.8	70	2.3				57	4.5	60	4.5	61	4.0	63	3.6	64	3.5	67	2.8	70	2.3	85
90	55	3.7	58	4.2	60	3.7	61	3.3	63	3.2	66	2.7	69	2.2				55	3.7	58	4.2	60	3.7	61	3.3	63	3.2	66	2.7	69	2.2	90
95	53	2.8	56	3.7	58	3.4	59	3.1	61	3.0	64	2.6	67	2.1				53	2.8	56	3.7	58	3.4	59	3.1	61	3.0	64	2.6	67	2.1	95
100	51	2.1	54	2.9	56	3.1	58	3.0	59	2.7	63	2.4	65	2.0				51	2.1	54	2.9	56	3.1	58	3.0	59	2.7	63	2.4	65	2.0	100
110	45	1.0	49	1.6	51	1.9	52	2.2	56	2.3	59	2.1	61	1.9				45	1.0	49	1.6	51	1.9	52	2.2	56	2.3	59	2.1	61	1.9	110
120										51	1.9	54	1.9	57	1.8																	120
130										48	1.0	51	1.4	53	1.5																	130
Telescoping conditions %																																
Tel. 1	100	100										100	100										Tel. 1									
Tel. 2	100	100										100	100										Tel. 2									
Tel. 3	80	100										80	100										Tel. 3									
Tel. 4	80	100										80	100										Tel. 4									
Code	51	53	55	71	73	75	61	63	65	81	83	85	Code																			

Main Winch Line Pull is 13,500 lbs and Aux. Winch Line Pull is 10,000 lbs
To attain lift capacities in excess of 10,000 lbs with single part line Main Winch must be used.

Operation and Maintenance of this machine must be in compliance with the information provided in the "Operation and Maintenance Manual" supplied with this machine.

WARNING AND OPERATING INSTRUCTIONS FOR LIFTING CAPACITIES ATF-1000XL

GENERAL

1. Total rated loads shown on the TADANO LOAD RATING CHART apply only to the machine as originally manufactured and normally equipped by TADANO. Modifications to the machine or use of optional equipment other than that specified can result in a reduction of capacity.
2. Construction equipment can be dangerous if improperly operated or maintained. Operation and maintenance of this machine must be in compliance with the information in the operation, safety and maintenance manual supplied with the machine. If this manual is missing, order replacement through the distributor.
3. The operator and other personnel associated with this machine shall fully acquaint themselves with the latest applicable American National Standards Institute (ANSI) safety standards for cranes.

SET UP

1. Total rated loads shown on the TADANO LOAD RATING CHART are the maximum allowable crane capacities and are based on the machine standing level on firm supporting surface under ideal job conditions. Depending on the nature of the supporting surface, it may be necessary to have structural supports under the outrigger floats or tires to spread the load to a larger bearing surface.
2. For on outrigger operation, outriggers shall be extended according to the TADANO LOAD RATING CHART with tires free of supporting surface, before operating crane.

OPERATION

1. Total rated loads with outriggers fully extended do not exceed 85% of the tipping loads as determined by SAE Crane Stability Test Code J-765. Total rated loads with outriggers half extended or on tires do not exceed 75% of the tipping loads as determined by SAE Crane Stability Test Code J-765.
2. Total rated loads above the bold lines in the TADANO LOAD RATING CHART are based on crane strength and those below the bold lines on crane stability.
3. Total rated loads include the weight of the main hook block, auxiliary hook ball, sling and other auxiliary lifting devices and all their weights shall be subtracted from the listed capacities to obtain the net load to be lifted.

Hook Ball/ Hook Block	6.6			22			44			69			110		
No. of parts of line	1	2	3	4	5	6	7	8	10	11	12	15	17		
Max. lift cap. (ton)	6.6	13.2	19.8	26.4	33.0	39.7	44.0	51.3	62.8	67.8	73.9	88.2	100		
Weight (lbs)	330			440			880			1,320			2,550		

4. The lifting capacity ratings specified in the TADANO LOAD RATING CHART apply to the telescopic boom without extendible fly jib fixed in transport position or working position. If the extendible fly jib is secured to the telescopic boom in transport position or working position, the lifting capacities of the telescopic boom are reduced by the values specified below. The weight of the extendible fly jib (2,150 lbs) is detected in terms of a load, and the load moment limiter will shut off earlier.

29.53/52.50 ft. extendible fly jib, mounted in transport position	1,000 lbs
29.53 ft. extendible fly jib, mounted to the boom head	2,500 lbs
52.50 ft. extendible fly jib, mounted to the boom head	4,410 lbs

5. Total rated loads are based on freely suspended loads and make allowance for such factors as the effect of wind, sudden stopping loads, supporting surface conditions, inflation of tires, operating speeds, side loads, etc. Side pull on boom or jib is extremely dangerous.
6. Total rated loads do not account for wind on lifted load or boom. Total rated loads and boom length shall be appropriately reduced, when wind velocity is above 20 mph (29 ft/sec.).
7. Total rated loads at load radius shall not be exceeded. Do not tip the crane to determine allowable loads.
8. Do not operate at boom lengths beyond radii or boom angles where no capacities are shown. Crane may overturn without any load on the hook.
9. Slewing of the superstructure is admissible only when the crane is supported on half or fully extended outriggers.
10. When making lifts at a load radius not shown, use the next longer radius to determine allowable capacity.
11. Load per part line should not exceed 13,500 lbs for the main winch and should not exceed 10,000 lbs for the auxiliary winch.
12. Loaded boom angles are approximate. The boom angle before loading should be greater to account for deflection.
13. The 36.75' boom length capacities are based on the telescopic boom being fully retracted. If not fully retracted (less than 62' boom length), use the total rated loads for the 62' boom length according to the telescoping sequence.
14. Extension or retraction of the telescopic boom with loads may be attempted within the limits of the TADANO LOAD RATING CHART. The ability to telescope loads is limited by hydraulic pressure, boom angle, boom length, crane maintenance, etc.
15. When erecting or stowing the extendible fly jib, be sure to retain it hand or by other means to prevent its free movement.
16. Use the Anti-Two Block (OVERWIND CUTOUT) disable switch when erecting or stowing the extendible fly jib and stowing the hook block. While the switch is pushed, the hoist will not stop, even when an overwind condition occurs.
17. The working radius specified in the TADANO LOAD RATING CHARTS for the extendible fly jib apply only if the telescopic boom is completely extended. If one or more elements of the telescopic boom are retracted partially or completely, the specified boom angles will be decisive in determining total rated lifting capacities.
18. When lifting a load by using the extendible fly jib (auxiliary hoist) and telescopic boom (main hoist) simultaneously, do the following:
 - A. Select the correct program for the load moment device in accordance with jib length, jib offset angle, counterweight and outrigger base.
 - B. Before starting the operation, make sure that the weight of the load is within the total rated load for the extendible fly jib.
19. Safe Load Indicator
Before working with the telescopic boom, make sure that the S.L.I. code is set according to the desired telescoping sequence while the telescopic boom is completely retracted. A change of the telescoping sequence is not permissible when the boom has been partially or fully extended. In order to change the S.L.I. code number, the boom must be fully retracted.

20. Working with Single Top

Operation with the single top is only allowed with the auxiliary winch (2nd winch). The maximum allowed line pull is 10,000 lbs.

For operations with the single top mounted, use the TADANO LOAD RATING CHART for the telescopic boom in accordance with existing counterweight and outrigger base to find the total rated lifting capacity and also select the correct S.L.I. code for the telescopic boom in accordance with the existing counterweight and outrigger base. Find the total rated lifting capacity based on boom length and working radius. From that value, subtract 1,100 lbs and the weights of all lifting equipment used including hook block, sling and other auxiliary lifting devices. The result is the total rated lifting capacity for a single top lift. However, remember that the maximum total rated lifting capacity for a single top operation is 10,000 lbs. When the result of the above calculation (<total rated lifting capacity> - <1,100lbs> - <lifting equipment>) is over 10,000 lbs, always regard the total rated lifting capacity as 10,000 lbs.

DEFINITIONS

- 1. Working Radius: Horizontal distance from a projection of the axis of rotation to supporting surface before loading to the center of the vertical hoist line or tackle with load applied. The deflection of the boom due to its deadweight and the rated load are taken into account.
- 2. Loaded Boom Angle: The angle between the boom base section and the horizontal, after lifting the total rated load at the working radius.
- 3. Working Area: Area measured in a circular arc about the centerline of rotation.
- 4. Freely Suspended Load: Load hanging free with no direct external force applied except by the hoist line.
- Side Load: Horizontal side force applied to the lifted load either on the ground or in the air.

WARNING AND OPERATING INSTRUCTIONS FOR ON RUBBER CAPACITIES

- 1. Total rated lifting capacities on rubber are in pounds and do not exceed 75% of tipping loads as determined by test in accordance with SAE J-765.
- 2. Total rated lifting capacities shown in the TADANO LOAD RATING CHART are based on the condition that the crane is set on firm level supporting surfaces with suspension let down to block. Those above the bold lines are based on tire capacity and those below the bold lines on crane stability. They are based on actual load radius increased by tire deformation and boom deflection.
- 3. Total rated lifting capacities are based on proper tire inflation, capacity and condition. Damaged tires are hazardous to safe operation of the crane.
- 4. Tires shall be inflated to correct air pressure
 - Tire Air Pressure
 - 20.5 R 25-100 psi (7 kgf/cm²)
- 5. On rubber lifting with "extendible fly jib" is not permitted.
- 6. When making a lift on rubber, set the parking brake.

7. Traveling with the load is permitted only if the following conditions exist:

Machine is set on firm level supporting surface: tires inflated to specified pressure: boom must be centered over the rear of the machine: superstructure swing lock pin engaged: slewing brake engaged; maximum boom length not to exceed 62'; lifted load kept as close to the ground as possible and fastened to the chassis to prevent the lifted load from swinging or oscillating; travel slowly with a creeping speed not to exceed 1.6 mph; and especially avoid any abrupt steering, accelerating or braking.

If possible, extend the outriggers and lower the outrigger floats to just above ground level.

8. Do not operate the crane while carrying the load.

LOAD MOMENT DEVICE (PAT 350DS)

The Load Moment Device (PAT 350DS) is intended as an aid to the operator. Under no condition should it be relied upon to replace use of Load Rating Charts and Operating Instructions. Sole reliance upon the Load Moment Device Aids in place of good operating practice can cause an accident. The operator must exercise caution to assure safety.



All Terrain Taxi Crane

ATF-1000XL

- 138.12ft five section full power boom + 52.5ft two stage boom extensions
- rugged 8×8×8 carrier for true on/off highway performance (48.5 mph)
- optimal weight distribution and transport weight
- ergonomically designed panoramic cabs - for comfort and safety
- two engines 375 HP (chassis) and 158.2 HP (crane)



