



# OPERATIONS AND MAINTENANCE MANUAL

## **GANTRY FRAME AND MUD MAT**

D-0071625, REV. B



 Operations & Maintenance Manual	<b>GANTRY FRAME AND MUDMAT</b>	D-0071625  Revision A August 28, 2007
---	--------------------------------	--



## OPERATIONS AND MAINTENANCE MANUAL

### Gantry Frame and Mud Mat

*"This document is the property of Oceaneering International Inc., and may not be used for any purpose unless authorized in writing by Oceaneering and which, upon demand, shall be returned to Oceaneering. The document contains Oceaneering confidential, proprietary information and shall not be copied, reproduced, used, transferred to other documents or disclosed to others for any purpose unless specifically authorized in writing by Oceaneering."*

#### RECORD OF REVISIONS

This page records the revision status of the entire procedure and its authorization for issue. When revised, the affected parts of the document will be noted in the "Remarks" column.

Rev.	Date	By	Chec	Approved	Remarks
A	9 May 2007	RGB	KL	MR	
B	28 Aug 2007	RGB	KL	MR	Add figures for alternate panel mounting



## Table of Contents

1. Introduction	4
2. General Description	4
2.1 Mud Mat	5
2.2 Gantry	6
2.2.1 Frame	6
2.2.2 Span Trolley	8
2.2.3 Winch Trolley	8
2.2.4 Trolley Drives	9
2.2.5 Winch	11
2.2.5.1 Winch Brake	14
2.2.6 Winch Compensator	15
2.2.7 ROV Interface Panel	16
3. Specifications	19
4. Reference Documents	20
5. Pre-Deployment Set Up	21
5.1 Mud Mat Assembly	21
5.2 Gantry Assembly	24
6. ROV Integration	27
7. Pre-Dive and Deck Testing	28
8. Deployment	31
9. Tool Operations	32
9.1 XY Travel	32
9.2 Z Hoisting/Lowering	33
10. Post Dive Maintenance	35
11. Transportation	36
12. Long Term Storage	37

## List of Tables

Table 1 - Specifications	19
Table 2 – Oceaneering Reference Documents	20
Table 3 – Hot Stab Flow, Pressure, and Valve Requirements	27

## 1. Introduction

This document contains a functional description of and instructions for assembling, operating, and maintaining the Oceaneering pipeline repair gantry frame.

*The ROV crew and tool operator should read this manual thoroughly before deploying or operating the tool.*

## 2. General Description

The Oceaneering gantry frame was developed for lifting a spool piece during pipeline repair tasks. Specifically, the gantry is intended to provide a vertical lift at the center or predetermined point on a horizontal jumper spool piece during installation. In the event of difficulty aligning the jumper spool connectors, the gantry is deployed over the spool and the spool piece is lifted to minimize misalignment due to sag in the jumper. This is done without introducing the heave problems that are associated with lifting using a vessel down wire.

The system consists of a gantry frame and a mud mat. The mud mat is placed into position prior to the jumper or spool piece being installed. The gantry consists of a support frame trolley that travels a hydraulic winch over a 10' x 10' X-Y area centered in the frame center. The gantry legs land on the mud mat in 4 "pie pan" receptacles.

The gantry can be used for other lifting tasks, provided that receptacles for landing are incorporated and that the landing structure can support both the gantry and load weights.

Both the gantry frame and mud mats are designed as bolt together modules that can be broken down and shipped on standard flat bed trucks without permit loads.

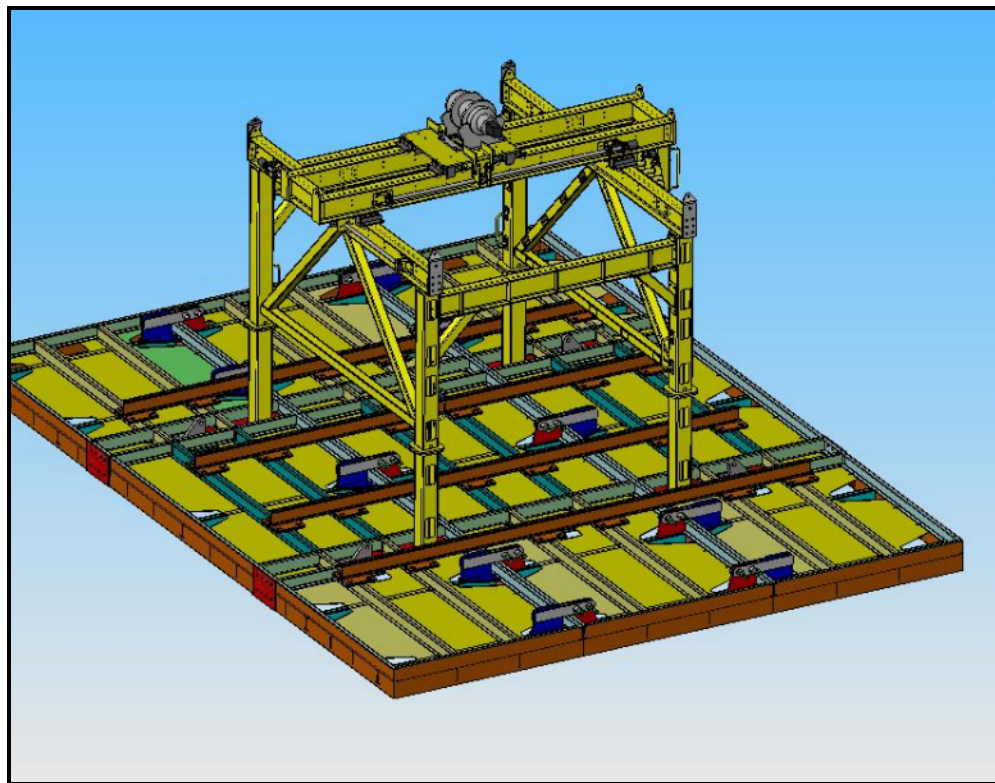

Figure 1 - Gantry and Mud Mat

## 2.1. Mud Mat

The mud mat is an assembly consisting of 3 each 10' x 40' sections. When assembled, the mat has a 30' x 40' footprint. When the mat is disassembled it can be transported on standard flatbed trucks.

The 3 sections are held together by 10 pinned connections and strengthened with 4 bolted-in stiffener beams.

The mud mat is lifted by a 4 part sling attached to lifting eyes.



Figure 2 - Mud Mat

## 2.2. Gantry

The gantry consists of a support frame, span trolley, winch trolley, trolley drives, hydraulic winch with compensator, and an ROV interface panel.

### 2.2.1. Frame

The gantry frame provides support for the trolleys and open access for the ROV to operate the winch hook. The main frame feet have flanges to which legs are bolted on. These bolt-on legs extend the height 4' beyond the basic height of frame side supports without increasing shipping dimensions and sizes. Longer legs can be fabricated if required. Figure 2 depicts the gantry with extension legs bolted on.



Figure 3 - Gantry Frame (Extensions Removed)



Figure 4 - Frame Flange Foot (Extension Removed)

### 2.2.2. Span Trolley

The span trolley is the main traveling cross member between the two gantry frame side supports. It rides on stainless steel roller assemblies and is positioned hydraulically using a hydraulic motor driving an acme screw. The span trolley provides one direction of horizontal travel for the winch.



Figure 5 - Span Trolley

### 2.2.3. Winch Trolley

The winch trolley runs on the span trolley and provides the other direction of horizontal travel for the winch. It rides on the same type of rollers as the span trolley and is driven by the same acme drive system as the span trolley.





Figure 6 - Winch Trolley

#### 2.2.4. Trolley Drives

Both the span and winch trolleys ride on stainless steel rollers and are driven by acme screws powered by hydraulic motors. The acme screw is rigid mounted and the bronze drive nut is housed in a cushioned assembly that allows some mechanical misalignment of the screw and nut drive.

Both trolley drives have markings and stops at the end of travel on both ends. The trolleys are marked at 6" intervals across the spans. At the end of travel there is a spring on the Acme screw and a bright red line. When the catch plate contacts the spring or crosses the red line, the trolley is at the end of travel. There are rigid stops on top of the I-beam tracks. The trolleys will contact the rigid stops after crossing the end of travel mark and compressing springs about 50%.

***NOTE: The trolley travel should always be monitored near the end of travel points and stopped manually prior to contacting the rigid stops. Allowing contact with the rigid stops may cause damage to the acme screws, drive nut, catch plates or drive nut.***



Figure 7 - End of Travel



Figure 8 - Stainless Steel Rollers and Acme Drives



Figure 9 - Acme Drive Hydraulic Motor

### 2.2.5. Winch

The main lift winch is an off the shelf Gearmatic GH-50 marine hydraulic winch that has been modified to prepare it for subsea use. The winch is rated to maximum line pull of 44,000 (lb) but is de-rated for use with the gantry to match the system rating of 32,000 (lb).

The winch has an automatic brake. It is spring applied and hydraulically released, fail safe. The brake is released only when hydraulics are applied to the main drive hydraulic motor.



Figure 10 - Hydraulic Winch

The winch is spooled with about 75' of 7/8" 6x19 wire rope. This is enough for about 1.5 layers of rope on the drum. The intention is to always have one complete layer on the drum during use for anchoring. The half layer of working wire leaves about 25 feet, which more than sufficient to reach the load connection point at the bottom of the gantry.

The wire rope is terminated on the winch side with a "button" stop anchor and on the ROV working end with a spelter socket. The socket is connected to a 25 ton swivel hook with a shackle.

***NOTE: In the event of ROV access issues to the hook the wire can be terminated with custom connections not requiring ROV access to the interior of the gantry frame.***

The wire comes off the winch drum vertically down and passes through a set of rollers mounted underneath the winch trolley.



Figure 11 - Winch Trolley Rollers



Figure 13 - Wire End Termination and Swivel Hook

The following modifications have been made to the winch to make it acceptable for subsea use and controllable by ROV.

- The hydraulic drive motor shaft normally has no shaft seals to allow oil to pass into the winch housing for cooling. Oceaneering DTS installed shaft seals into the motor to keep oil from passing from the drive circuit to the winch housing (because the winch housing must be isolated from hydraulic supply for the compensating system).
- The winch gears normally have a light 1 way seal to keep a small amount of gear oil in the gear box cavity. Oceaneering DTS replaced this seal with a bi-directional seal to keep water out and allow the winch internal volume to be completely filled with and hold compensating oil.
- The winch drum has been drilled and tapped for 2 each NPT plugs to allow access for air bleeding and complete filling of the winch internal volume with oil.
- One internal seal has been removed by the manufacturer to allow communication between all normally air filled spaces for compensation with oil.
- A compensator has been added to provide a volume of oil to the housing at slightly over ambient pressure (1-3 psi).
- The hydraulic brake release piston has a small hole to allow cooling oil to flow into the winch housing when operating winch. This hole has been plugged to isolate the winch internal volume from the hydraulic drive fluid.

#### **2.2.5.1. Winch Brake**

The winch brake is spring set and hydraulically released when pressure is supplied to the “haul in” port of the drive motor. There is a ¼” line teed into the motor connection port to supply this pressure. It is critical that operators understand the function of the brake and how it releases and sets. When there is about 100 (psi) of differential pressure across the motor supply ports (as indicated on ROV panel gauges Z1 and Z2), then the brake releases. This occurs during normal haul in operation.

However, there are two other possible ways to develop this pressure and release the brake. The ROV panel has an open center directional control valve (DCV) installed as required by the winch manufacturer. The normal sequence of winch operation is:

1. Select direction using pilot controlled DCV.
2. Actuate winch motor hydraulic supply to start motion.
3. Secure winch motor hydraulics supply to stop motion.
4. Return DCV to center position.

The first way to unintentionally release the brake is to operate the winch motor hydraulic supply (winch Z supply) with the DCV centered, i.e. with winch direction not selected. This can allow a pressure differential across the motor ports that can

release the brake. It will not hurt the winch or hydraulic equipment but it is considered an undesirable situation.

The second way to unintentionally release the brake is by not using an open centered control valve on the ROV DCV valve providing hydraulic supply to the winch motor. If a closed center valve is used, it will block pressure to the winch motor circuit as indicated on panel gauges Z1 and Z2. As the pressure slowly bleeds off through the valve spool, it is possible to develop a differential pressure in the direction and magnitude required to release the brake. Again, this will not cause any damage to the gantry systems but is not a desirable situation.

To prevent either of these situations from occurring, **it is critical to use an open center DCV for ROV control of the winch hydraulic motor supply and always follow the operational procedural steps for actuating panel DCV and winch motor supply hydraulics.**

***WARNING: Failure to use an open center directional control valve for the winch motor hydraulic supply or not following the winch operational control procedures can result in unintentional release of the winch brake.***

### 2.2.6. Winch Compensator

The winch compensator is installed to provide the winch housing with a volume of oil at slightly over ambient pressure (1-3 psi). This oil compensates the normally air filled spaces in the housing and drum to keep them from being damaged under external seawater pressure and also keeps water out of the winch's internal mechanisms. The compensator is connected to the winch body voids through 2 Parflex hoses and has a pressure gauge to monitor compensator pressure.



Figure 14 - Winch and Hydraulic Compensator

### 2.2.7. ROV Interface Panel

The ROV interface panel provides the control and interface connection for the ROV. The panel consists of 3 hot stab receptacles, 4 gauges, and 2 ROV paddle valves.

The ROV hot stab receptacles provide ROV connection points for hydraulics to the horizontal trolley travel (X-Y), the winch supply (Z), and the winch pilot. The Z supply provides the hydraulic fluid to run the winch. The Z pilot operates a directional control valve to select between “up” and “down” movement of the load.

The ROV paddle valves are used to select between X (span trolley) and Y (winch trolley) operation. Both valves should be set to either X or Y travel position.

The XY gauges 1 and 2 indicate differential pressure across the X-Y (horizontal) supply and return lines. The Z gauges 1 and 2 read the differential pressure across the Z (winch) supply and return lines. The gauges are provided for visual indication of operations rather than exact pressure monitoring.

The gantry can be supplied with alternate panel mounting hardware in order to mount the panel along the side of the gantry main frame rather than directly on the span trolley. Figures 15a and 15b depict alternate mounting of the control panel. Mounting the panel in alternate positions does not change the hydraulic plumbing, only the routing of the control hoses. Additional hoses of sufficient length will be supplied with panel relocation hardware if purchased.





Figure 15 – ROV Interface Panel

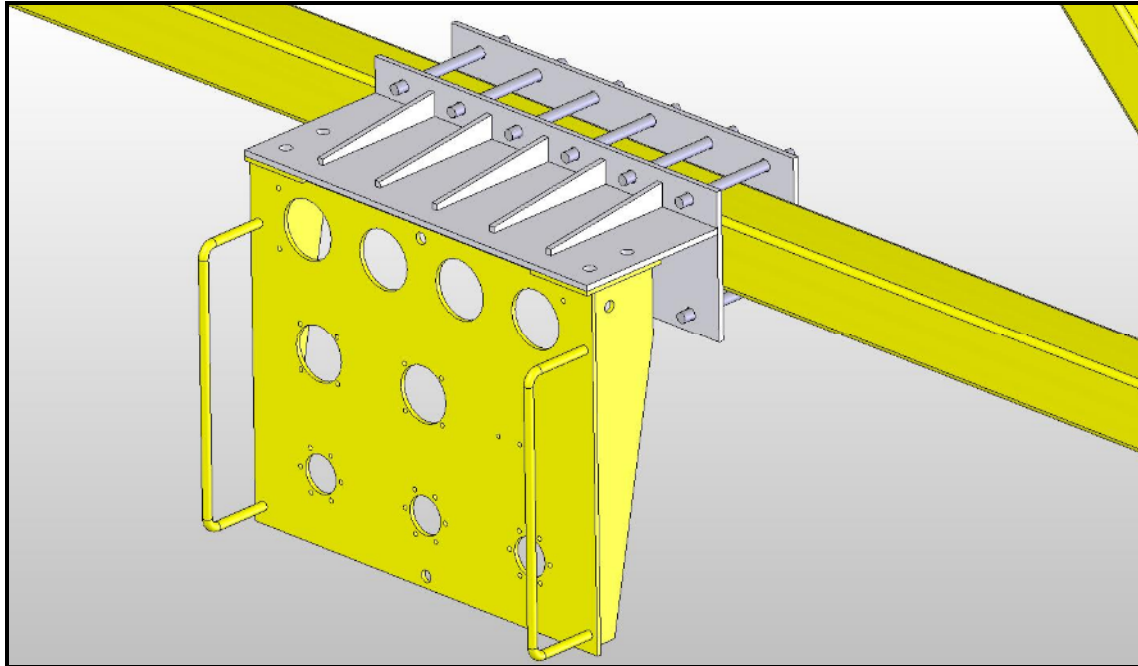

Figure 15a - ROV Interface Panel Alternate Mounting

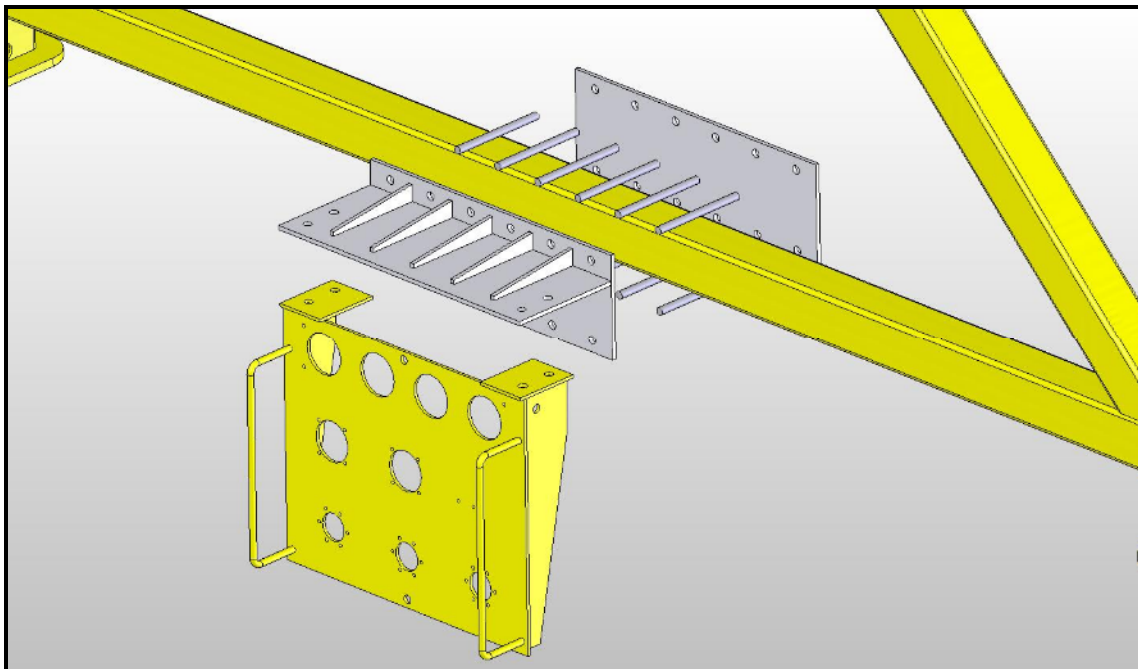

Figure 15b - ROV Interface Panel Alternate Mounting



### 3. Specifications

Table 1 summarizes the specifications and weights of the system:

Vertical Lift (Z) Capability	32000 (lb)
Horizontal (X-Y) Travel	10'
Vertical (Z) Travel	100"
Horizontal (X-Y) Loading	Capable of providing 32000 (lb) vertical while traveling in X-Y with system on a 7 degree incline
Gantry Weight (In Air)	18000 (lb)
Mud Mat Weight (In Air)	41000 (lb)
Incline	+/- 7 degrees

**Table 1 - Specifications**



#### 4. Reference Documents

Table 2 lists the Oceaneering (OI) documents to be used as reference materials when operating, assembling, or maintaining the gantry.

<b>OI Document Number</b>	<b>Description</b>
0292322	Mud Mat Sections
0298678	Gantry Frame and Crane Assembly
0298679	Mud Mat Assembly
0300412	Mud Mat and Gantry Assembly
0304112	Gantry Hydraulic Schematic

**Table 2 – Oceaneering Reference Documents**

## 5. Pre-Deployment Setup

Prior to deployment offshore, the gantry and mud mats need to be assembled and tested. This should be done on land and then the mud mats and gantry shipped offshore completed and ready to lift and lower subsea.

***WARNING: The gantry and mud mats should not be assembled offshore on a vessel.***

### 5.1. Mud Mat Assembly

The mud mats are assembled using pins and bolts. Each mud mat assembly consists of 3 each 10' wide x 30' long sections. One section is the center and two are the end/outside sections. See assembly drawings listed in Section 4 for reference. The procedure listed below outlines steps for assembly of the mud mat.

1. Lay out center section and 2 each end sections as per assembly drawings.

***NOTE: The mats are marked with weld beads as 1, 2 and 3 as sets to ensure they are placed in same positions as initial shop fit up for ease of assembly.***



Figure 16 - Mud Mat Marking

2. Place all hinge weldments in location and install bolts. Do not tighten or impact bolts yet.

3. Insert all pins through hinges and install secondary keeper pins.



Figure 17 - Bolted and Pinned Hinge Connection

4. Install stiffener beams and bolts. Do not tighten or impact bolts yet.

**NOTE:** The stiffeners are marked with weld beads as A, B, C, and D as sets to ensure they are placed in same positions as initial shop fit up for ease of assembly. Letters should be aligned as shown in Figure 18. The stiffener beam bolts have wings to allow removal by impact wrench by ROV if required.

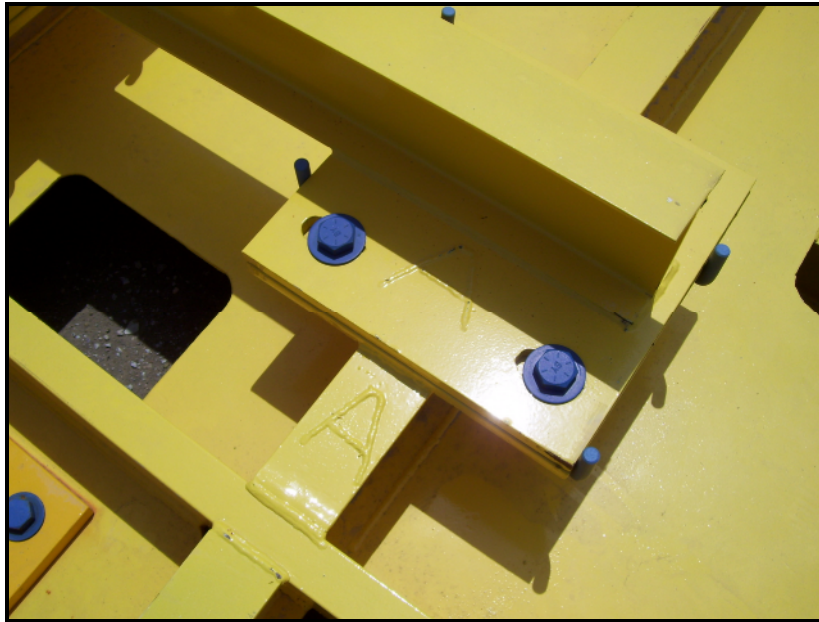

Figure 18 - Stiffener Marking Letters

5. Impact tight all bolts.
6. Install lifting pad eyes and impact lifting eye bolts.



Figure 19 - Lifting Pad Eye and Sling Connection

7. Install lifting slings.

## 5.2. Gantry Assembly

The gantry is bolted together and assembled in sections. The following instructions outline the assembly procedure. See reference assembly drawings.

1. Assemble and install Acme screw drives and catch assemblies on both the span trolley and main frame. The yellow drive catch plates should be left loose/hanging on the Acme thread at this point – will not be bolted to trolleys yet.

**NOTE: The acme screw assembly mounting bolts should be left hand tight at this point to allow alignment when trolleys are mounted on tracks and acme drives connected to pusher plates.**



Figure 20 - Drive Catch Plates

2. Bolt together the gantry side weldments, connecting beams, and impact bolts

**NOTE: The gantry frames have been assembled at DTS facility using either a crane or two forklifts.**

3. Bolt in the corner supports and impact bolts.



4. Completely assemble winch and span trolleys including rollers and winch.
5. Install the winch trolley onto the span trolley and install lower roller wheels on roller frames to catch on underside of track beams.



Figure 21 - Winch Trolley Lower Rollers

6. Bolt the span trolley catch acme plates to the winch trolley.
7. Install the span trolley onto gantry frame and install lower roller wheels on roller frames to catch on underside of track beams.
8. Bolt the gantry catch acme plates to the span trolley.
9. Bolt the ROV control panel to the span trolley.

**NOTE: There is an option to purchase a remote panel or jumper panel. If this option is used install the remote/jumper panel in desired location.**

10. Connect hydraulic hoses between ROV panel and winch/trolley drive connection points as per hydraulic schematic listed in Section 4.
11. Travel the winch and span trolleys over their full range of motion with the acme system mounting bolts still loose/hand tight. See tool operation section for controls operation.

12. Adjust acme mounts for proper vertical positioning. This is done by driving a trolley to its end of travel and then tightening the acme drive mounts nuts **ON THE SIDE THE TROLLEY IS AT WHEN AT THE END OF TRAVEL**. Then the trolley is traveled to the opposite end of the acme screw to end of travel and the acme drive mounting bolts on that side tightened.

***WARNING: Vertical adjustment of the acme screw mounting brackets relative to the drive catch acme nut position is critical to proper operation of the gantry drives. Failure to perform this adjustment can result in damage to the gantry mechanisms, frames and acme screws.***



## 6. ROV Integration

The ROV interface with the tool consists of either 2 or 3 API 17H hot stabs. The below table summarizes the hot stab flow, pressure and valve requirements.

Function	Pressure (psi)	Flow (gpm)	Valve Spool Center Condition	Proportional Pressure/Flow Control
X/Y Horizontal Travel	2200	10	Open Center (A & B to Tank)	Preferred, not required
Z Vertical Lift Supply	2200	10	Open Center (A & B to Tank)	Preferred, not required
Z Vertical Lift Pilot	1500	3	Open Center (A & B to Tank)	No

Table 3 – Hot Stab Flow, Pressure, and Valve Requirements

To use system with 3 hot stabs, the stabs should be set up as per the above table and marked so they are used to control proper function.

If two hot stabs are to be used rather than 3, then one stab should be set up and marked for the Z vertical lift pilot and should be used for that function only. The second stab should be set up for and switched between X/Y horizontal travel and Z vertical lift supply as needed.

It is critical that open center condition hydraulic control valves are used, especially with the Z vertical lift supply. The brake operation depends on a tank for proper setting and holding of the brake.

## 7. Pre-Dive and Deck Testing

Prior to deployment sub sea the gantry shall be completely assembled and the below pre-dive/deck test completed. General deck testing can be done with an auxiliary power unit (APU) hydraulic supply but it is imperative to test all functions with the ROV controls to verify proper integration.

1. Verify proper assembly of gantry according to reference drawings and assembly procedure.
2. Ensure proper adjustment of the acme screw vertical mounting settings.
3. Check all structural and equipment mounting bolts for tightness.
4. Install (3) hot stabs into ROV interface panel, ensuring that correct stabs are installed to corresponding functions.
5. Ensure ROV/HPU functions are set to proper pressure and flow.
6. Ensure that both X/Y ROV paddle valves are both to the X or both to the Y position.

***Warning: The two ROV paddles valves for X/Y travel direction selection should always be set to the same positions. The X/Y function should never be operated unless both valves are set to X or both set to Y or there may be damage to the acme screw drives. When X/Y function is not being used, both valves should be set to the "off" positions.***

7. Turn on HPU and function X/Y. Travel either in either the X or Y direction over the full range of motion (to both end of travel indicators) and back to center. Look for smooth operation of trolleys and acme drives. Make adjustments as required. Verify immediately after applying hydraulics that acme drive screws are BOTH turning and rotating in the same direction.

***WARNING: Connecting the hoses to the motor circuits incorrectly and operating the drives can cause severe damage to the acme drive mechanisms, rods, drive catch plates, trolley rollers or gantry frame. The motor should always be verified to be both turning and in the same direction.***

8. Set the X/Y selection valves to the other direction. Function the other trolley along its full range of motion and return to center. Look for smooth operation of trolleys and acme drives. Make adjustments as required.

9. Set both X/Y paddle valves to the “off” position.
10. Select either “up” or “down” depending on hook position (if wire installed) using the ROV/APU directional control valve for the Z vertical lift pilot.
11. Actuate Z vertical lift supply and verify proper rotation of drum (up/down).
12. Stop Z lift vertical supply and select other direction with the Z lift pilot. Verify proper rotation of drum (up/down).

***NOTE: When operating the vertical lift, the pilot direction should always be selected prior to actuating supply to lift or lower load. To stop the load the supply shall be shut off. The supply should not be operated without selection of either the “up” or “down” direction as this may cause the hydraulic brake to release and the load to under its own weight. This is not harmful to the gantry system but is not the proper method of operation for controlled load lifting and lowering.***

13. If winch drum has wire installed, use the Z controls to remove all the wire.
14. Completely inspect the wire and replace if required.

***NOTE: The winch wire should be replaced with new wire prior to each mobilization and discarded after each offshore deployment. When not in use the wire should be removed from the drum and stored out of the elements, preferably in a dry storage box.***

15. Rotate the winch drum so that one plug is at top dead center and one at bottom dead center.
16. Perform air and water checks on all winch body penetrations, drum plugs, and compensator. Completely flush compensator and housing/drum with clean hydraulic oil and ensure comp pressure is 3-5 (psi).

***CAUTION: Comp pressure should be kept below 5 (psi); pressures above 10 (psi) may damage the winch oil filled spaces and seals.***

17. Pass wire rope bitter end through rollers and install wire end anchor on wire.
18. Install wire rope end anchor into winch rope receiver and spool wire rope onto drum. Ensure that there are approximately 1.5 full drum layers of rope (about 75’).
19. Remove hot stabs and install dummy stabs into hot stab receptacles.



Operations & Maintenance  
Manual

## GANTRY FRAME AND MUDMAT

D-0071625

Revision A  
August 28, 2007

20. Apply light coat of grease (red military type recommended) to acme screws.
21. Apply light coat of rust inhibitor (LPS- or similar) to carbon steel acme drive components (bearing housings, etc).

## 8. Deployment

Deployment of both the mud mat and gantry are done using vessel or barge crane. A heave compensated crane or lift system is preferred. If a heave compensated lift system is not used, it is up to the installation contractor to determine safe sea state for deployment and sea bed installation operations. Without heave compensation the mud mat deployment should be limited to less than 3 ft vertical heave/seas as large heave will significantly increase dynamic loading.

General installation order:

1. Deploy mud mat and lower to sea bed.
2. Position mud mat using installation contractor procedures. Assume use of survey or pre-installed buoys for proper positioning.
3. Disconnect mud mat lifting slings.
4. Deploy gantry frame.
5. Position gantry over mud mat and use ROV directions to make final lowering to position into mat receptacles.
6. If non-DTS mud mat or alternate platform is being used for gantry support, then install gantry as per installation contractor procedures.
7. Disconnect gantry slings from down wire and pull off to side to ensure they don't interfere with gantry operations.
8. Reconnect down wire when gantry operations are complete.
9. Lift gantry from support structure/mud mat and recover to deck.

***NOTE: The mud mats are designed to be left in place after use and are not intended to be recovered. In as intended/designed operations, the mud mat will be placed prior to the pipe or spool piece in the event that lifting is required to manipulate spool piece end flanges to make up connections. As such, the mud mat will be under the pipe/spool after installation.***

## 9. Tool Operation

Once the gantry is in position subsea, the below guidelines can be used for general operations. Prior to subsea operations, the ROV integration and pre-dive shall be completed.

### 9.1. X/Y Travel

The X/Y travel can be used to both position the hook and to apply slight side loads. The gantry is specified to operate at full load (32 kip). Similarly it can be used to apply a side load but only up to a maximum deviation of 7 degrees from vertical as defined by gravity, not relative to the mud mat inclination.

It is preferable to spot the hook directly above the load for lifting but up to 7 degrees of inclination is acceptable.

#### **X/Y Travel Procedure:**

1. Install X/Y travel hot stab.
2. Ensure that both of the ROV XY travel direction valves are set to either X or Y as desired.
3. Turn on ROV supply with pressure and flow set to required levels up to 2200 (psi) and 10 (gpm).

***NOTE: If proportional pressure control is available, it is recommended to always ramp up pressure slowly from zero and only apply the required pressure to induce motion. This minimizes the risk of damage should one of the trolleys be traveled to the hard stops or in the event of some mechanical problem.***

4. ROV Check pressure at gauges and verify pressure on motor lines. These gauges tie directly to the motor supply lines and are installed for easy monitoring of system hydraulics.
5. ROV check BOTH acme drive screws to ensure they are both rotating and turning in the same direction.
6. ROV monitor acme screw, gauges and hook location during travel as required.
7. ROV secure hydraulics to stop motion when load is in correct position or an end or travel position is reached.



## 9.2. Z Hoisting/Lowering

The following procedure should be followed for Z hoisting and lowering. Operators should ensure they are familiar with brake operation as described in section 2.2.5.1 winch brake prior to operating the winch.

1. ROV install hot stabs into Z pilot and Z supply receptacles.
2. Select “up” for hoisting using the Z pilot directional control valve, hydraulics set to 1500 (psi) and 3 (gpm). This will set the winch direction, no motion will occur yet.
3. Apply Z supply pressure and flow at 2200 (psi) and 10 (gpm) max. This will start the winch motor and begin hoisting.

**NOTE: If proportional pressure control is available, it is recommended to always ramp up pressure slowly from zero and only apply the required pressure to induce motion. This minimizes the risk of damage in the event of some mechanical problem.**

4. ROV monitor hook and Z1/Z2 gauges as required. These gauges are plumber directly to the winch motor drive lines. They are installed to provide easy monitoring of hydraulic supply conditions.

**WARNING: The ROV must carefully monitor the hook during hoisting when the hook is near the winch trolley rollers. Running the spelter socket into the rollers can cause catastrophic damage to the rigging, the load being lifted or the gantry components and structure.**

5. When the hook is in desired position ROV stop the winch Z supply hydraulics. This will stop the load from moving and set the brake.

**NOTE: When lowering the load, especially at faster speeds, it is normal for the hook to continue to travel a slight amount (less than one inch) before the drum stops and the brake sets and locks the load. This is due to inertia of the load and the need for supply lines to reach 0 (psi) bleeding back to tank to set the brake. The slower the load is moved (lower winch supply flow rates) the less effect this inertia will have on the load stopping and brake setting.**

6. ROV inspect gauges Z1 and Z2. Both gauges should read zero.

**WARNING: If both winch supply lines (Z1 and Z2) do not depressurize to 0 (psi) there is a possibility of the brake not setting completely or releasing when they do bleed back to zero and unintentional motion of the hook/load is possible.**



7. ROV secure hydraulics to the directional control valve. This will not result in any motion, only the directional control valve retuning to center position.
8. ROV remove hot stabs from panel.

***NOTE: Once the winch supply lines (Z1 and Z2) are at 0 (psi) and the brake is set, the hot stabs can be removed and the load will be held with the brake without ROV intervention.***

## 10. Post Dive Maintenance

1. Rinse ROV panel, winch, trolley rollers and acme drive screws and mechanisms with fresh water.
2. Inspect gantry frame, winch and mechanisms for damage, repair as required.
3. Thoroughly inspect rigging. Replace damaged or worn components as required.

***NOTE: The 7/8" wire rope provides a 2:1 factor of safety for the rated 32 (kip) static lift (no shock or dynamic loads) rated capacity. It also allows reasonable spooling on the winch drum, decreased likelihood of bird caging on the drum, and good ROV handling of hook. The factor of safety depends on the wire being in good condition. The rope shall be replaced if there is any damage, wear or weathering. Several spare sections or rope are recommended for offshore operations as they need only be 75' long.***

4. Set up APU or ROV hot stabs as in pre-dive/deck testing and ROV integration sections.
5. Run both span and winch trolleys through full range of XY travel. Ensure smooth motion and make repairs or adjustments as required.
6. Run winch Z hook up and down; ensure proper and smooth operation of winch.
7. Perform air and water checks on winch. Check all compensator access points to body and drum and compensator itself. If any water is found in the winch body compensated volumes completely drain the comp system of oil, flush with clean oil and refill. This will require removing wire from the winch drum to access the NPT ports on the drum.
8. Flush compensator and winch housing with clean oil.
9. Install dummy stabs.
10. Check all structural and equipment mounting bolts for tightness.



## **11. Transportation**

As noted above the gantry and mud mats both break down at the bolted connections for storage or shipping. The assembly procedure can be followed in reverse for disassembly prior to shipping or storage.

When disassembled all the components are 10' wide or less on at least one side to allow trucking on a standard flat bed without permits. The mud mat sections are 10' by 40' and the large gantry side sections are 10' by 16'. See reference drawings for complete dimensions and weights.

## 12. Long Term Storage

The system can be stored in any degree of assembly or disassembly as conditions and space allow.

Indoor (warehouse) storage out of the elements is preferred for mechanical and hydraulic components. It is highly recommended that, at a minimum, the winch trolley (with winch, compensator system, etc.), ROV interface panel, and hydraulic hoses be removed, wrapped in shipping plastic and stored in a warehouse type environment rather than outside in the elements.

1. Perform post dive checks and completely drain, flush, and refill winch housing and compensator with clean oil and pressurize comp to 1-2 (psi).
2. Clean old grease from acme screws and apply light coat of new grease (red military type recommended) to acme screws. Wrap exposed acme screws, couplings, and hydraulic drive motors with plastic wrap, especially if stored outside in elements.
3. Apply light coat of rust inhibitor (LPS-3 or similar) to carbon steel acme drive components (bearing housings, etc).
4. Remove wire rope, hook, and swivel and store in job/spares box.
5. Wrap winch trolley (including winch, compensator, etc.) with plastic or cover with a tarp, especially if stored outside exposed to elements.
6. Wrap ROV interface panel with plastic or cover with a tarp, especially if stored outside exposed to elements.