

# MR 295

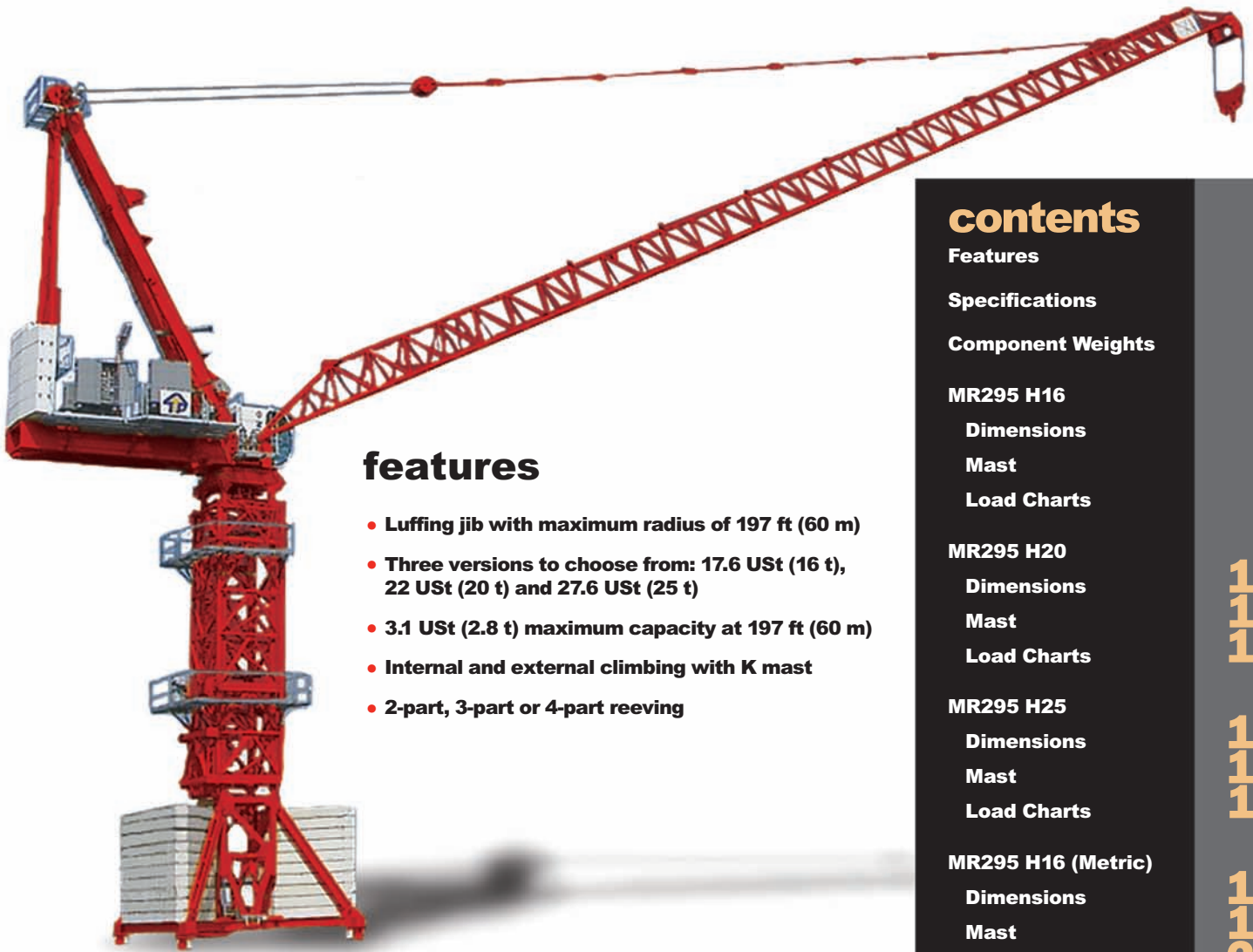

## product guide



### features

- Luffing jib with maximum radius of 197 ft (60 m)
- Three versions to choose from: 17.6 USt (16 t), 22 USt (20 t) and 27.6 USt (25 t)
- 3.1 USt (2.8 t) maximum capacity at 197 ft (60 m)
- Internal and external climbing with K mast
- 2-part, 3-part or 4-part reeving

### contents

Features	2
Specifications	3
Component Weights	5
<b>MR295 H16</b>	<b>6</b>
Dimensions	6
Mast	7
Load Charts	8
<b>MR295 H20</b>	<b>10</b>
Dimensions	10
Mast	11
Load Charts	12
<b>MR295 H25</b>	<b>14</b>
Dimensions	14
Mast	15
Load Charts	16
<b>MR295 H16 (Metric)</b>	<b>18</b>
Dimensions	18
Mast	19
Load Charts	20
<b>MR295 H20 (Metric)</b>	<b>22</b>
Dimensions	22
Mast	23
Load Charts	24
<b>MR295 H25 (Metric)</b>	<b>26</b>
Dimensions	26
Mast	27
Load Charts	28
Symbols Glossary	30

# features

2



Seven (7) different jib lengths from 98 ft (30 m) to 197 ft (60 m) in 16 ft (5 m) increments make the MR 295 flexible to match the needs of your jobsite. In addition, the MR 295 can be placed on 6,6 ft (2 m) mast for compact spaces or 8 ft (2.45 m) mast for even taller free standing height.



The optional SM/DM hookblock allows the crane to be operated in 2-part, **3-part** or 4-part line applications for greater performance on the jobsite.



With a fixed counterweight, the MR 295 has less moving parts and a more compact counterjib.



Vision cab V140SR is equipped with all of the standard features of the V140S with the addition of a glass window on the ceiling for excellent visibility with a luffing-jib tower crane.

MR 295

# specifications

3



## Jib

98 ft (30 m) radius standard lattice jib. Catwalks in all sections for maintenance and easy access to sling points for erection and dismantling. Identification plates are welded on each section. The jib foot attaches to the pivot point and locks in place with two (2) pins. Inspection platform is fixed to the jib nose and equipped with plates on each side for advertising decals.



## \*Optional Jib Extensions

Six (6) optional jibs are available for radii from 115 ft (35 m) to 197 ft (60 m).



## Counter-Jib

One 27.2 ft (8.3 m) design for all jib configurations. Hoisting and luffing winches, ballast, and servicing derrick are all located on the counter-jib. Maintenance is easy with grated platforms and grab rails fitted on each side. Four (4) pins connect the counter-jib to towerhead. Collecting devices prevent the pins from falling during removal.



## Ballast (customer supplied)

Two (2) concrete block styles for various ballasting combinations according to jib length: 2,205 lb (1000 Kg) and 8,708 lb (3950 Kg). Blocks are held in place by rods and a locking system.



## Cab

140 SR Vision cab is standard and includes heating, window vent, tinted glass, windshield wipers, sun visor, document case, side pocket, bottle holder, ergonomic seat with high back, adjustable armrests, height and seating with control units, front-to-back shifting and reclining back.



## Controls

Dual axis joystick controls via umbilical cord at ground level. In cab controls at seat standard, \*remote control with dual axis joysticks optional.



## Reeving

SM hookblock for 2-part line application standard. \*Optional SM/DM hookblock for 2, 3 or 4-part line applications optional.



## Electrical Requirement

480 volt, 60 Hz measured at the turntable.



## Dialog Visu & \*Anemometer

Dialog Visu is standard and displays information to the operator such as height under hook, radius, loads and overload moment, and wind speed (when \*anemometer is ordered). Other anemometer options: wind speed alarm, indicator for ground, and recorder.

\*Denotes optional equipment



## Swing

RVF 182 Optima + slewing mechanism with maximum swing speed of 0.8 RPM. Progressive control of speed with counter-slewing possible, anti-load swinging system makes aligning the load and jib easier.



## Hoist

Hoist is specific to version selected:

17.6 USt (16 t):	75 LVF 40 Optima
22 USt (20 t):	100 LVF 50 Optima
27.6 USt (25 t):	150 LCC 63

Optional hoists include:

100 LVF 40	(17.6 USt [16 t])
150 LCC 40	(17.6 USt [16 t])
150 LCC 50	(22 USt [20 t])

### 75 LVF 40 Optima 100 LVF 50 Optima 150 LCC 63

Single Line Pull:	4.4 USt (4 t)	5.5 USt (5 t)	6.9 USt (6.25 t)
Hook speed:	295 ft/min (90 m/min)	308 ft/min (94 m/min)	361 ft/min (110 m/min)
Horse Power:	75 HP	100 HP	150 HP
Spooling Capacity:	2,090 ft (637 m)	3,727 ft (1136 m)	3,583 ft (1092m)

Specification of quantity of hoist rope is dependent upon customer's requirements and mast height.



## Luffer

100 VVF 40: 100 HP variable frequency hoist with a luffing time of one (1) minute forty (40) seconds from 15° to 86°.

## \* Optional Equipment

\* STANDARD NORTH AMERICAN SPECIFICATION MR 295-H20: includes electric slip ring, 150LCC50 hoist, 230 ft (70), cable 2x4G 50mm<sup>2</sup>, 197 ft (60 m) jib radius, heating mechanisms for the control panel and hoist motor, SM/DM hookblock, 820 ft (250 m) hoist rope, cab equipped with insulation, and anemometer.

\* Additions to the above Standard North American Specification for respective models:

17.6 USt (16 t): 150 LCC 40 hoist

- \* Electric slip ring
- \* Jib radius 115 – 197 ft (35 – 60 m)
- \* SM/DM Hookblock
- \* Anemometer
- \* Motorized greasing

Consult price list for additional options

NOTE: The information above is useful as a basic introduction to the crane. In no case may this serve as a substitute for the serial numbered manuals. Dimensions have been rounded to the nearest tenth.

MR 295

# specifications

4

## Mast

K mast in sizes of K600 (6.6 ft [2 m]) or K800 (8.0 ft [2.45 m]), panel or monoblock, and climbing or non-climbing available. Lengths of 10.9 ft (3.33 m), 16.4 ft (5 m), and 32.8 ft (10 m) available. Identification plates welded on each section to designate the type of mast and pin box to stow pins when not in use.

Mast nomenclature:

K – Series of mast with box angled members

M – Monoblock, non climbing

R – Reinforced

MT – Monoblock & climbing

RMT – Reinforced, monoblock, climbing

Equipped with aluminum ladders and galvanized steel resting platforms in each section. Cast connections are secured with two double tapered pins.

\*Tirax tool and \*Tirax pins available for faster easier assembly.

NOTE: Combinations of masts can allow free-standing HUH to increase.

## Climbing Equipment

Equipment available for both internal climbing and external climbing of both 6.6 ft (2 m) and 8.0 ft (2.45 m) mast. Internal climbing equipment sold separately: hydraulic unit, jack, and collars. External climbing equipment sold separately: climbing cage, hydraulic unit, yoke, and jack.

## Anchor Stools

Anchor stools to be used in combination with a concrete foundation.

Anchors P62A or P60US: permanent anchor, maximum free-standing HUH: 172.2 ft (52.5 m) for 6.6 ft (2 m) K mast.

Anchors P800A or P800US: permanent anchor, maximum free-standing HUH: 211.6 ft (64.5 m) for 8.0 ft (2.45 m) K mast.

## Chassis

Chassis available with square footprint of 19.7 ft (8 m) for K600 and K800 mast. Composed of 2 metallic structures connected with a central mast-chassis and 4 struts for rigidity. A chassis can be placed on straight or curved traveling equipment or metallic stools embedded into a concrete block.

Chassis V60A: square footprint of 19.7 ft (8 m), free-standing HUH: 172.6 ft (52.6 m) for 6.6 ft (2 m) K mast, 98 ft (30 m) jib.

Chassis Y800A: square footprint of 19.7 ft (8 m), free-standing HUH: 231.0 ft (70.4 m) for 8.0 ft (2.45 m) K mast, 98 ft (30 m) jib.

## Cross Shaped Base

A cross shaped base is available with a square footprint of 19.7 ft (6 m). Composed of two (2) beams and able to be placed on screw jacks with support plates, screw jacks with concrete blocks or traveling equipment.

Cross ZX6830 on K600: square footprint of 19.7 ft (6 m), free-standing HUH 180.8 ft (55.1 m) on 6.6 ft (2 m) K mast.















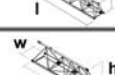

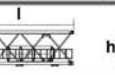
Cross ZX6830 on K800: square footprint of 19.7 ft (6 m), free-standing HUH 166.7 ft (50.8 m) on 8.0 ft (2.45 m) K mast.

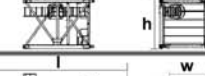
*\*Consult price list for additional options*

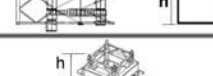
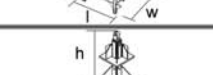
# component weights

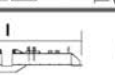
5

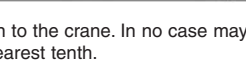
## Component Weights

Item	Qty.		l ft (m)	w ft (m)	h ft (m)	weight lb (kg)
1	1	Towerhead 2m 	9.8 (2.98)	7.5 (2.28)	10.3 (3.14)	20,172 (9 150)
2	1	Counter-jib 	24.4 (7.43)	16.9 (5.15)	15.4 (4.7)	15,432 (7 000)
3	1	Hoisting winch 150 LCC 50 	11.8 (3.6)	5.4 (1.64)	5.9 (1.8)	9,039 (4 100)
4	1	Cab V140SR 	11.2 (3.4)	6.2 (1.9)	9.0 (2.75)	3,806 (1 160)
5	1	Tower top 	24.9 (7.6)	10.8 (3.3)	10.8 (3.3)	15,465 (7 015)
6	1	Jib foot 	33.7 (10.3)	6.2 (1.9)	6.5 (2.0)	3,241 (1 470)
7	X	Jib section 	17.0 (5.2)	5.9 (1.8)	5.5 (1.7)	1,429 (648)
8	X	Jib section 	33.4 (10.2)	5.9 (1.8)	5.5 (1.7)	2,709 (1 229)
9	1	Jib section 	38.7 (11.8)	6.0 (1.8)	6.5 (2.0)	4,462 (1 360)
10	X	KR639A 	17.2 (5.2)	6.8 (2.1)	6.7 (2.0)	10,646 (3 245)
11	X	K639C 	11.7 (3.6)	6.8 (2.1)	6.7 (2.0)	4,376 (1 985)
12	X	KR839A2 	17.2 (5.2)	8.1 (2.5)	8.3 (2.5)	9,105 (4 130)
13	X	KR839C2 	11.8 (3.6)	8.1 (2.5)	8.3 (2.5)	6,856 (3 110)
14	1	T60A External climbing cage 	36.7 (11.18)	14.4 (4.39)	13.5 (4.13)	18,155 (8 235)
15	1	T800A External climbing cage 	33.4 (10.2)	18.4 (5.6)	15.4 (4.7)	28,600 (12 973)
16	1	K800/KR60 	10.6 (3.2)	8.1 (2.5)	7.3 (2.2)	9,750 (4 423)
17	4	Fixing angle P60US 	2.0 (0.61)	2.0 (0.61)	4.7 (1.4)	1,100 (499)
18	4	Fixing angle P800US 	2.5 (0.8)	2.5 (0.8)	5.9 (1.8)	1,477 (670)
19	1	Cross shaped base: ZX6830 	29.9 (9.1)	2.5 (0.8)	4.9 (1.5)	12,004 (5 445)
	1	Cross shaped base: ZX6830 	29.9 (9.1)	3.7 (1.1)	3.6 (1.1)	11,607 (5 265)

NOTE: The information above is useful as a basic introduction to the crane. In no case may this serve as a substitute for the serial numbered manuals. Dimensions have been rounded to the nearest tenth.



# dimensions

## MR 295 H16

6

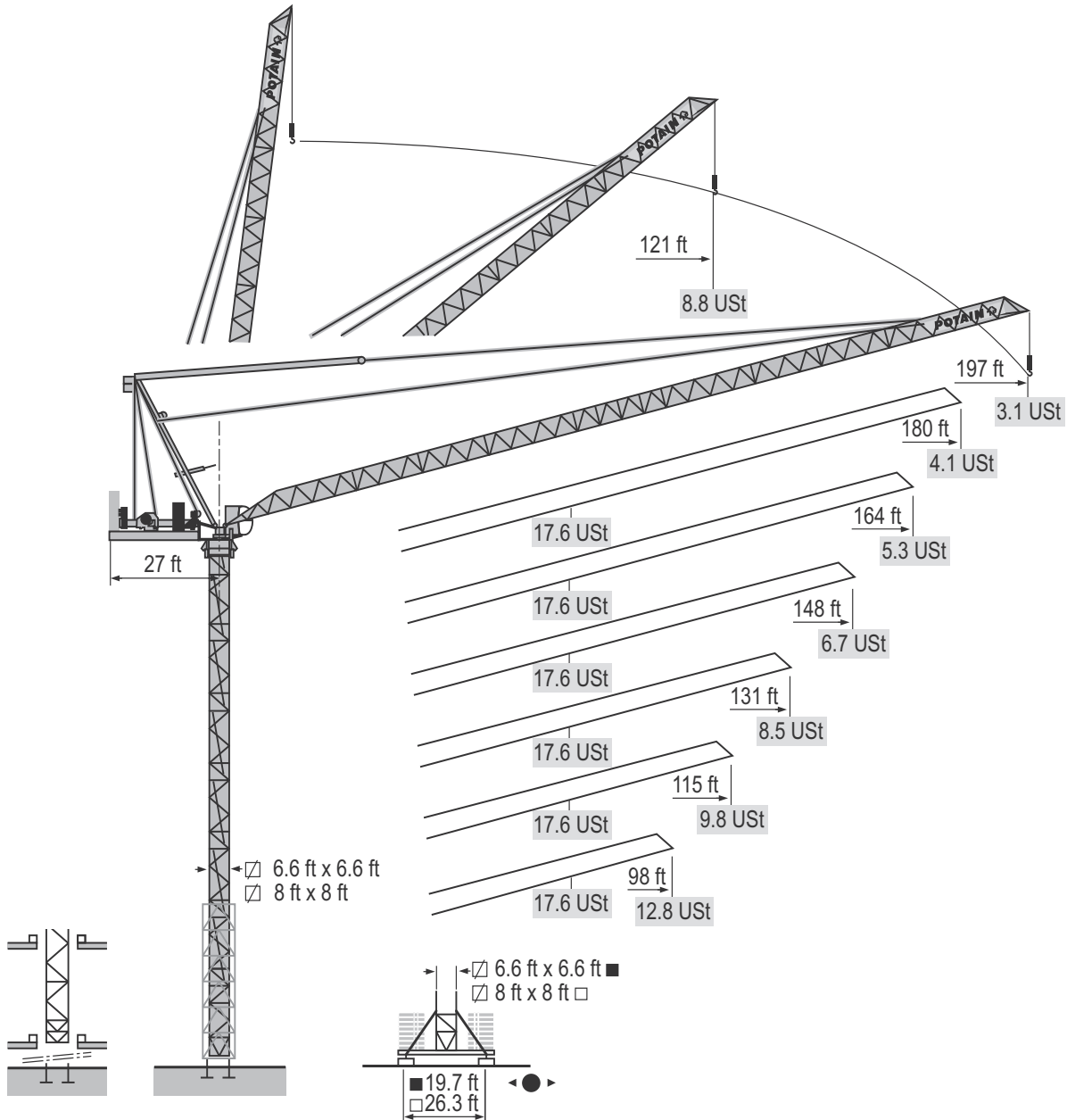

MR 295

THIS CHART IS ONLY A GUIDE AND SHOULD NOT BE USED TO OPERATE THE CRANE. The individual crane's load chart, operating instructions and other instructional plates must be read and understood prior to operating the crane.

## MR 295 H16

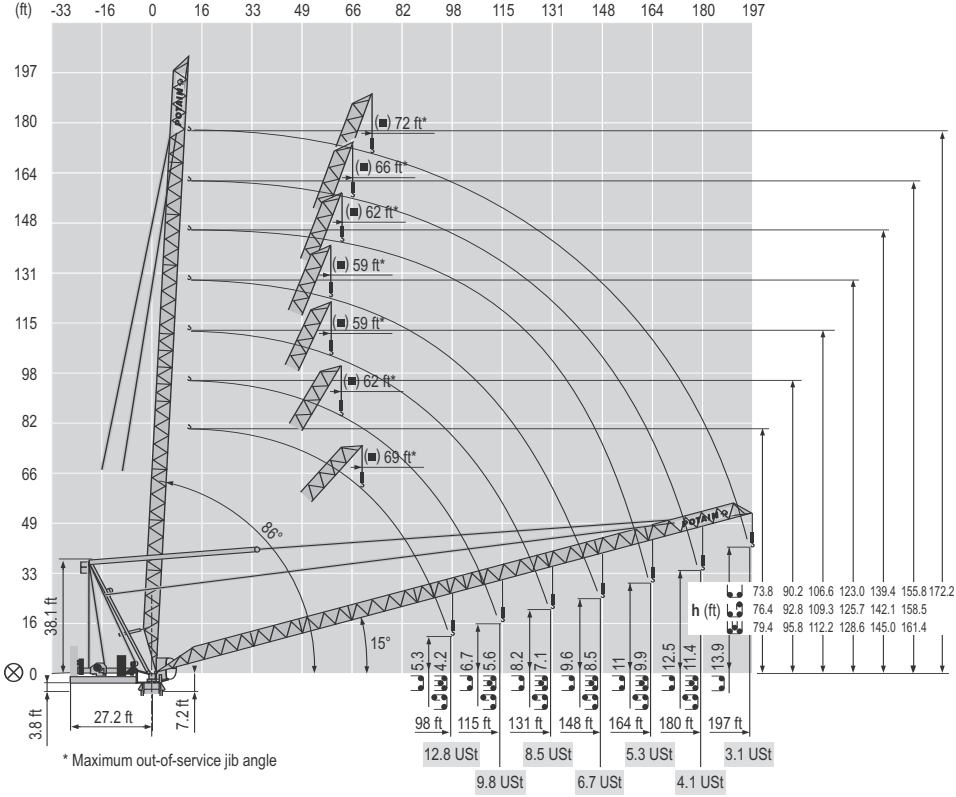

\* Maximum out-of-service jib angle

### K600 Mast

98 - 115 ft

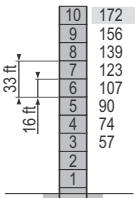

P 62 A

Hook	H (ft)	16 ft	11 ft
10	172		
9	156		
8	148	9	1
7	139	8	2
6	164	156	-
5	180	145	7
4	197	139	8
3			
2			
1			

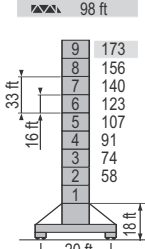

V 60 A

Hook	H (ft)	16 ft	11 ft
9	173		
8	156		
7	140		
6	123		
5	107		
4	91		
3	74		
2	58		
1			



B 60 A

Hook	H (ft)	16 ft	11 ft
10	172		
9	161		
8	145		
7	128		
6	112		
5	96		
4	79		
3	63		
2			
1			

### K800 Mast

98 ft

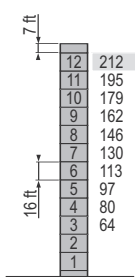

P 800 A

Hook	H (ft)	16 ft	11 ft
12	212		
11	195		
10	179		
9	162		
8	146		
7	130		
6	113		
5	97		
4	80		
3	64		
2			
1			

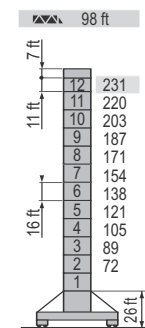

Y 800 A

Hook	H (ft)	16 ft	11 ft
12	231		
11	220		
10	203		
9	187		
8	171		
7	154		
6	138		
5	121		
4	105		
3	89		
2	72		
1			



B 800 B

Hook	H (ft)	16 ft	11 ft
12	212		
11	200		
10	184		
9	168		
8	151		
7	135		
6	118		
5	102		
4	86		
3	69		
2	53		
1			

NOTE: Illustrated hook heights on this page were determined using FEM 1.001. Configurations shown may include optional equipment. Other codes may require reductions in configurations.

# load charts

## MR 295 H16

8

### 3-Part Capacity

Hook Radius (ft)	Capacity (lb)						
	Jib Configuration						
	L60	L55	L50	L45	L40	L35	L30
20.0	17,837	17,837	17,837	17,837	17,837	17,837	17,837
30.0	17,837	17,837	17,837	17,837	17,837	17,837	17,837
40.0	17,837	17,837	17,837	17,837	17,837	17,837	17,837
50.0	17,837	17,837	17,837	17,837	17,837	17,837	17,837
60.0	17,837	17,837	17,837	17,837	17,837	17,837	17,837
70.0	17,837	17,837	17,837	17,837	17,837	17,837	17,837
80.0	17,837	17,837	17,837	17,837	17,837	17,837	17,837
90.0	17,837	17,837	17,837	17,837	17,837	17,837	17,837
100.0	17,837	17,837	17,837	17,837	17,837	17,837	17,837
<del>101.5</del>	17,837	17,837	17,837	17,837	17,837	17,837	<del>17,837</del>
110.0	17,837	17,837	17,837	17,837	17,837	17,837	17,837
<del>117.5</del>	17,837	17,837	17,837	17,837	17,837	<del>17,837</del>	
120.0	17,837	17,837	17,837	17,837	17,837		
130.0	15,543	16,122	16,503	16,783	17,224		
<del>133.5</del>	14,761	15,423	15,713	15,783	<del>16,424</del>		
140.0	13,446	14,106	14,327	14,840			
<del>146.5</del>	11,787	12,341	12,609	<del>13,067</del>			
150.0	11,840	12,240	12,531				
160.0	10,023	10,684	11,346				
<del>165.5</del>	9,330	10,432	<del>10,471</del>				
170.0	8,879	9,002					
180.0	7,335	8,217					
<del>181.5</del>	7,238	<del>8,157</del>					
190.0	6,834						
<del>195.5</del>	<del>6,173</del>						
Min. Radius:	16.4	16.4	16.4	13.1	13.1	13.1	9.8

### 3-Part Capacity

Hook Radius (ft)	Capacity (lb)						
	Jib Configuration						
	L60	L55	L50	L45	L40	L35	L30
20.0	20,455	20,455	20,455	20,455	20,455	20,455	20,455
30.0	20,455	20,455	20,455	20,455	20,455	20,455	20,455
40.0	20,455	20,455	20,455	20,455	20,455	20,455	20,455
50.0	20,455	20,455	20,455	20,455	20,455	20,455	20,455
60.0	20,455	20,455	20,455	20,455	20,455	20,455	20,455
70.0	20,455	20,455	20,455	20,455	20,455	20,455	20,455
80.0	20,455	20,455	20,455	20,455	20,455	20,455	20,455
90.0	20,205	20,465	20,465	20,465	20,465	20,465	20,465
100.0	22,734	23,000	23,395	23,722	24,277	24,852	24,852
<del>101.5</del>	22,022	22,403	22,883	23,124	23,505	<del>24,251</del>	
110.0	19,376	19,701	20,037	20,362	21,244		
<del>117.5</del>	17,139	17,547	17,788	18,519	<del>18,856</del>		
120.0	16,595	16,909	17,129	18,011			
130.0	14,221	14,579	15,401	15,543			
<del>133.5</del>	13,438	13,720	14,011	<del>14,727</del>			
140.0	12,122	13,007	13,224				
<del>146.5</del>	11,023	11,459	<del>11,424</del>				
150.0	11,023	11,307					
160.0	9,582	9,833					
<del>165.5</del>	8,889	<del>8,885</del>					
170.0	8,238						
180.0	6,894						
<del>181.5</del>	<del>6,885</del>						
190.0							
<del>195.5</del>							
Min. Radius:	16.4	16.4	13.1	13.1	13.1	9.8	

MR 295

THIS CHART IS ONLY A GUIDE AND SHOULD NOT BE USED TO OPERATE THE CRANE. The individual crane's load chart, operating instructions and other instructional plates must be read and understood prior to operating the crane.



# load charts

## MR 295 H16











9

### 4-Part Capacity / 2-Part Capacity

Hook Radius (ft)	Capacity (lb)						
	Jib Configuration						
	L80	L55	L30	L45	L40	L35	L30
20.0		35,274	35,274	35,274	35,274	35,274	35,274
30.0		35,274	35,274	35,274	35,274	35,274	35,274
40.0		35,274	35,274	35,274	35,274	35,274	35,274
50.0		35,274	35,274	35,274	35,274	35,274	35,274
60.0		35,274	35,274	35,274	35,274	35,274	35,274
70.0		35,274	35,274	35,274	35,274	35,274	35,274
80.0		31,089	31,426	31,731	32,087	32,748	33,274
90.0		26,009	26,230	26,450	26,991	27,552	27,993
100.0		21,738	22,073	22,399	22,940	23,395	24,512
<b>101.8</b>		21,140	21,360	21,801	22,237	22,678	<b>23,810</b>
110.0		18,378	18,715	19,039	19,376	20,808	
<b>117.6</b>		17,074	17,449	17,837	18,078	<b>18,409</b>	
120.0		16,595	16,909	17,129	17,637		
130.0		14,221	14,579	15,764	15,884		
<b>133.8</b>		13,438	13,729	14,862	<b>15,102</b>		
140.0		12,122	13,228	13,685			
<b>146.3</b>		11,464	11,787	<b>11,795</b>			
150.0		11,464	11,649				
160.0		9,854	10,023				
<b>165.2</b>		9,109	<b>9,149</b>				
170.0		8,459					
180.0		7,115					
<b>181.0</b>		<b>6,945</b>					
190.0							
<b>196.9</b>							
Min. Radius	16.4	16.4	13.1	13.1	13.1	9.8	

#### Notes:

1. Bold line indicates the division between 2-part line and 4-part line.
2. Deduct 1,102 lb when using 4-part line at a radius greater than the bold line.
3. Higher 2-part capacities can be achieved if the hanging block and the additional hook block are removed. (see load chart for 2-part capacity)

MR 295 H16 60 Hz													hp	kW	
	75 LVF 40 Optima	ft/min	0	112	144	249	295	0	56	72	125	148	75	55	2,090 ft
		USt	8.8	6.6	3.3	2.2	17.6	13.2	6.6	4.4					
	100 LVF 40 Optima	ft/min	0	144	184	308	381	0	72	92	154	190	100	75	
		USt	8.8	6.6	3.3	2.2	17.6	13.2	6.6	4.4					
150 LCC 40	ft/min	0	230	276	348	459	551	0	115	138	174	230	150	110	3,583 ft
	USt	8.8	6.6	4.4	2.2	1.1	17.6	13.2	8.8	4.4	2.2				
	100 VVF 40	ft/min	1 min 40 s									100	75		
	RVF 182 Optima +	rpm	0 0.8									2 x 12	2 x 9		
		ft/min													
CEI 38 			IEC 38					kVA							
480 V (+6% -10%) 60 Hz								75 LVF : 190 kVA 100 LVF : 220 kVA 150 LCC : 300 kVA							

THIS CHART IS ONLY A GUIDE AND SHOULD NOT BE USED TO OPERATE THE CRANE. The individual crane's load chart, operating instructions and other instructional plates must be read and understood prior to operating the crane.

# dimensions

## MR 295 H20

10

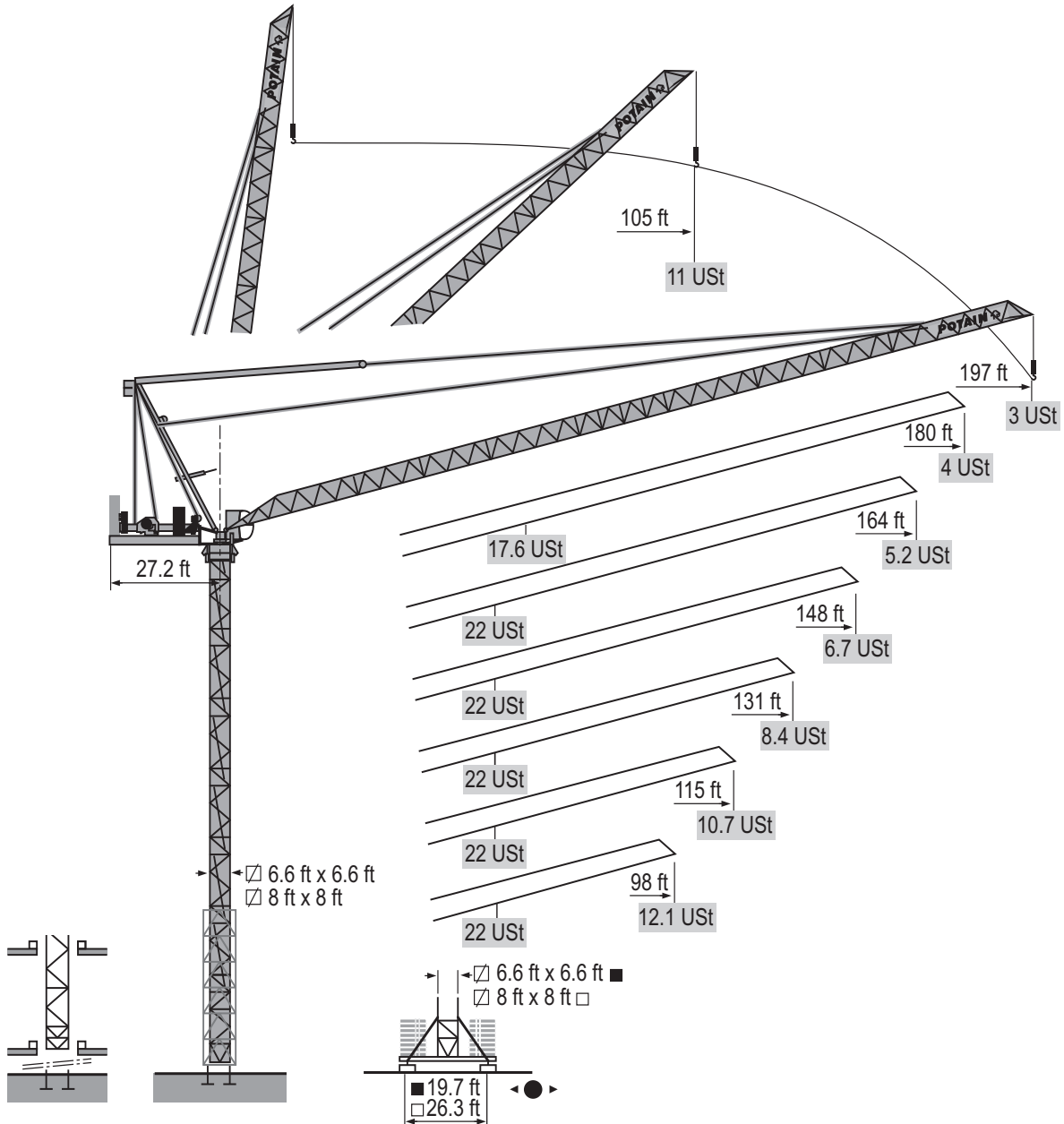

MR 295

THIS CHART IS ONLY A GUIDE AND SHOULD NOT BE USED TO OPERATE THE CRANE. The individual crane's load chart, operating instructions and other instructional plates must be read and understood prior to operating the crane.

## MR 295 H20

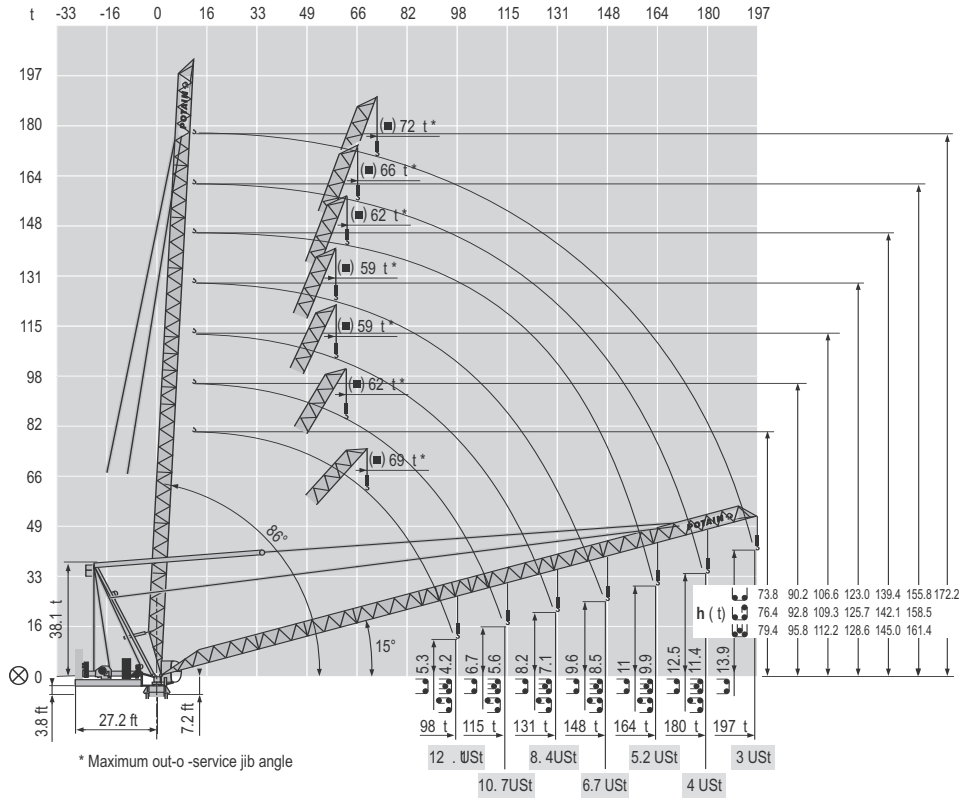

### K600 Mast

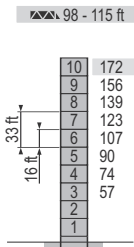

P 62 A

Angle	H (ft)	16 ft	11 ft
131 ft	167	9	1
148 ft	161	8	2
164 ft	156	9	2
180 ft	145	7	2
197 ft	139	8	-

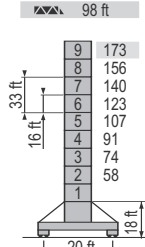

V 60 A

Angle	H (ft)	16 ft	11 ft
115 ft	156	8	-
131 ft	145	6	2
148 ft	135	6	1
164 ft	123	6	2
180 ft	113	4	2
197 ft	107	5	-



B 60 A

Angle	H (ft)	16 ft	11 ft
131 ft	167	8	2
148 ft	161	-	-
164 ft	156	8	1
180 ft	139	7	1
197 ft	128	7	-

### K800 Mast

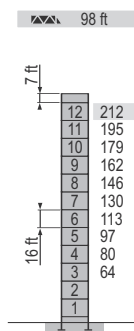

P 800 A

Angle	H (ft)	16 ft	11 ft
115 ft	200	10	2
131 ft	190	10	1
148 ft	184	9	2
164 ft	173	9	1
180 ft	168	8	2
197 ft	162	9	-

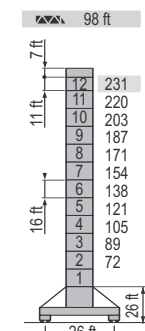

Y 800 A

Angle	H (ft)	16 ft	11 ft
115 ft	220	11	-
131 ft	209	9	2
148 ft	203	10	-
164 ft	193	8	2
180 ft	182	8	1
197 ft	176	7	2



B 800 B

Angle	H (ft)	16 ft	11 ft
115 ft	200	11	-
131 ft	190	9	2
148 ft	184	10	-
164 ft	173	8	2
180 ft	168	9	-
197 ft	162	8	1

THIS CHART IS ONLY A GUIDE AND SHOULD NOT BE USED TO OPERATE THE CRANE. The individual crane's load chart, operating instructions and other instructional plates must be read and understood prior to operating the crane.

# load charts

## MR 295 H20

12

### 2-Part Capacity

Hook Radius (ft)	Capacity (lb)						
	Jib Configuration						
	L00	L55	L50	L45	L40	L35	L30
20.0	22,040	22,040	22,040	22,040	22,040	22,040	22,040
30.0	22,040	22,040	22,040	22,040	22,040	22,040	22,040
40.0	22,040	22,040	22,040	22,040	22,040	22,040	22,040
50.0	22,040	22,040	22,040	22,040	22,040	22,040	22,040
60.0	22,040	22,040	22,040	22,040	22,040	22,040	22,040
70.0	22,040	22,040	22,040	22,040	22,040	22,040	22,040
80.0	22,040	22,040	22,040	22,040	22,040	22,040	22,040
90.0	22,040	22,040	22,040	22,040	22,040	22,040	22,040
100.0	22,040	22,040	22,040	22,040	22,040	22,040	22,040
<del>101.5</del>	22,040	22,040	22,040	22,040	22,040	22,040	<del>22,040</del>
110.0	20,582	20,803	21,140	21,581	21,813	22,040	22,040
<del>117.5</del>	18,429	18,940	18,870	19,343	19,752	<del>20,000</del>	22,040
120.0	17,790	18,011	18,231	18,672	19,113	22,040	22,040
130.0	15,323	15,543	15,902	16,342	17,004	22,040	22,040
<del>133.5</del>	14,541	14,761	15,052	15,403	<del>16,004</del>	22,040	22,040
140.0	13,224	13,445	13,665	14,106	22,040	22,040	22,040
<del>146.5</del>	11,567	11,787	12,121	<del>13,007</del>	22,040	22,040	22,040
150.0	11,429	11,649	12,028	22,040	22,040	22,040	22,040
160.0	9,803	10,074	10,950	22,040	22,040	22,040	22,040
<del>165.5</del>	9,109	9,921	<del>10,141</del>	22,040	22,040	22,040	22,040
170.0	8,459	9,381	22,040	22,040	22,040	22,040	22,040
180.0	7,997	7,997	22,040	22,040	22,040	22,040	22,040
<del>181.5</del>	7,802	<del>7,807</del>	22,040	22,040	22,040	22,040	22,040
190.0	6,853	22,040	22,040	22,040	22,040	22,040	22,040
<del>195.5</del>	<del>6,852</del>	22,040	22,040	22,040	22,040	22,040	22,040
Min. Radius	10.4	10.4	10.4	13.1	13.1	13.1	9.8

### 3-Part Capacity

Hook Radius (ft)	Capacity (lb)						
	Jib Configuration						
	L00	L55	L50	L45	L40	L35	L30
20.0	20,455	33,000	33,000	33,000	33,000	33,000	33,000
30.0	20,455	33,000	33,000	33,000	33,000	33,000	33,000
40.0	20,455	33,000	33,000	33,000	33,000	33,000	33,000
50.0	20,455	33,000	33,000	33,000	33,000	33,000	33,000
60.0	20,455	33,000	33,000	33,000	33,000	33,000	33,000
70.0	20,455	33,000	33,000	33,000	33,000	33,000	33,000
80.0	20,455	31,290	31,040	32,087	32,477	33,000	33,000
90.0	25,979	26,230	26,460	26,891	27,552	28,440	28,440
100.0	22,179	22,073	22,399	22,828	23,842	24,251	24,251
<del>101.5</del>	21,570	21,434	21,802	22,342	23,346	<del>23,810</del>	24,251
110.0	18,819	18,715	19,039	20,141	20,582	22,040	22,040
<del>117.5</del>	16,905	16,905	17,702	17,988	<del>18,122</del>	22,040	22,040
120.0	16,027	16,027	17,129	17,340	22,040	22,040	22,040
130.0	13,997	14,441	14,579	14,799	22,040	22,040	22,040
<del>133.5</del>	12,998	13,078	13,880	<del>13,877</del>	22,040	22,040	22,040
140.0	11,981	12,342	12,503	22,040	22,040	22,040	22,040
<del>146.5</del>	10,582	10,658	<del>10,714</del>	22,040	22,040	22,040	22,040
150.0	10,582	10,547	22,040	22,040	22,040	22,040	22,040
160.0	9,141	8,921	22,040	22,040	22,040	22,040	22,040
<del>165.5</del>	8,227	<del>8,113</del>	22,040	22,040	22,040	22,040	22,040
170.0	7,577	22,040	22,040	22,040	22,040	22,040	22,040
180.0	6,328	22,040	22,040	22,040	22,040	22,040	22,040
<del>181.5</del>	<del>6,170</del>	22,040	22,040	22,040	22,040	22,040	22,040
190.0	22,040	22,040	22,040	22,040	22,040	22,040	22,040
<del>195.5</del>	22,040	22,040	22,040	22,040	22,040	22,040	22,040
Min. Radius	10.4	10.4	13.1	13.1	13.1	13.1	9.8

MR 295

THIS CHART IS ONLY A GUIDE AND SHOULD NOT BE USED TO OPERATE THE CRANE. The individual crane's load chart, operating instructions and other instructional plates must be read and understood prior to operating the crane.

# load charts

## MR 295 H20

13

### 4-Part Capacity / 2-Part Capacity

Hook Radius (ft)	Capacity (lb)						
	Jib Configuration						
	L60	L55	L50	L45	L40	L35	L30
20.0	-	35,274	44,082	44,082	44,082	44,082	44,082
30.0	-	35,274	44,082	44,082	44,082	44,082	44,082
40.0	-	35,274	44,082	44,082	44,082	44,082	44,082
50.0	-	35,274	44,082	44,082	44,082	44,082	44,082
60.0	-	35,274	43,865	44,029	44,082	44,082	44,082
70.0	-	35,274	37,105	37,325	37,766	38,353	39,683
80.0	-	30,544	30,408	30,764	31,205	31,731	32,849
90.0	-	25,348	25,348	25,588	26,009	26,545	28,660
100.0	-	21,191	21,940	22,046	22,046	23,501	24,251
<b>101.8</b>	-	20,479	21,797	22,022	22,046	<b>22,899</b>	<b>22,818</b>
110.0	-	17,893	19,099	19,482	20,803	21,244	
<b>117.8</b>	-	16,886	16,886	18,429	18,649	<b>18,799</b>	
120.0	-	16,247	16,501	17,790	18,011		
130.0	-	13,917	15,020	15,240	15,323		
<b>133.5</b>	-	13,218	14,321	14,391	<b>14,551</b>		
140.0	-	11,901	13,004	13,004			
<b>149.3</b>	-	11,023	11,239	<b>11,244</b>			
150.0	-	11,023	11,147				
160.0	-	9,582	9,413				
<b>166.2</b>	-	8,813	<b>8,898</b>				
170.0	-	8,018					
180.0	-	6,674					
<b>181.0</b>	-	<b>6,814</b>					
190.0	-						
<b>195.8</b>	-						

Min. Radius	16.4	16.4	16.4	13.1	13.1	13.1	9.8
-------------	------	------	------	------	------	------	-----

#### Notes:

1. Bold line indicates the division between 2-part line and 4-part line.
2. Deduct 1,102lb when using 4-part line at a radius greater than the bold line.
3. Higher 2-part capacities can be achieved if the hanging block and additional hook block are removed. (see load chart for 2-part capacity)

MR 295 H20 60 Hz												hp	kW														
	100 LVF 50	ft/min	0	→	118	→	177	→	282	→	308	0	→	59	→	89	→	141	→	154	100	75	3,340 ft				
	Optima	USt			11		6.6		3.3		2.1			22		13.2		6.6		4.2							
	150 LCC 50	ft/min	0	→	190	→	223	→	282	→	374	→	453	0	→	95	→	112	→	141	→	187	→	226	150	110	2,579 ft
	Optima	USt			11		8.3		5.5		2.8		1.4			22		16.5		11		5.5		2.8			
	100 VVF 40	ft/min	1 min 40 s										100	75													
	RVF 182 Optima +	rpm	0 → 0.8										2 x 12	2 x 9													
		ft/min																									
CEI 38		IEC 38										kVA															
480 V (+6% -10%) 60 Hz												100 LVF : 220 kVA 150 LCC : 300 kVA															

MR 295

THIS CHART IS ONLY A GUIDE AND SHOULD NOT BE USED TO OPERATE THE CRANE. The individual crane's load chart, operating instructions and other instructional plates must be read and understood prior to operating the crane.

# dimensions

## MR 295 H25

14

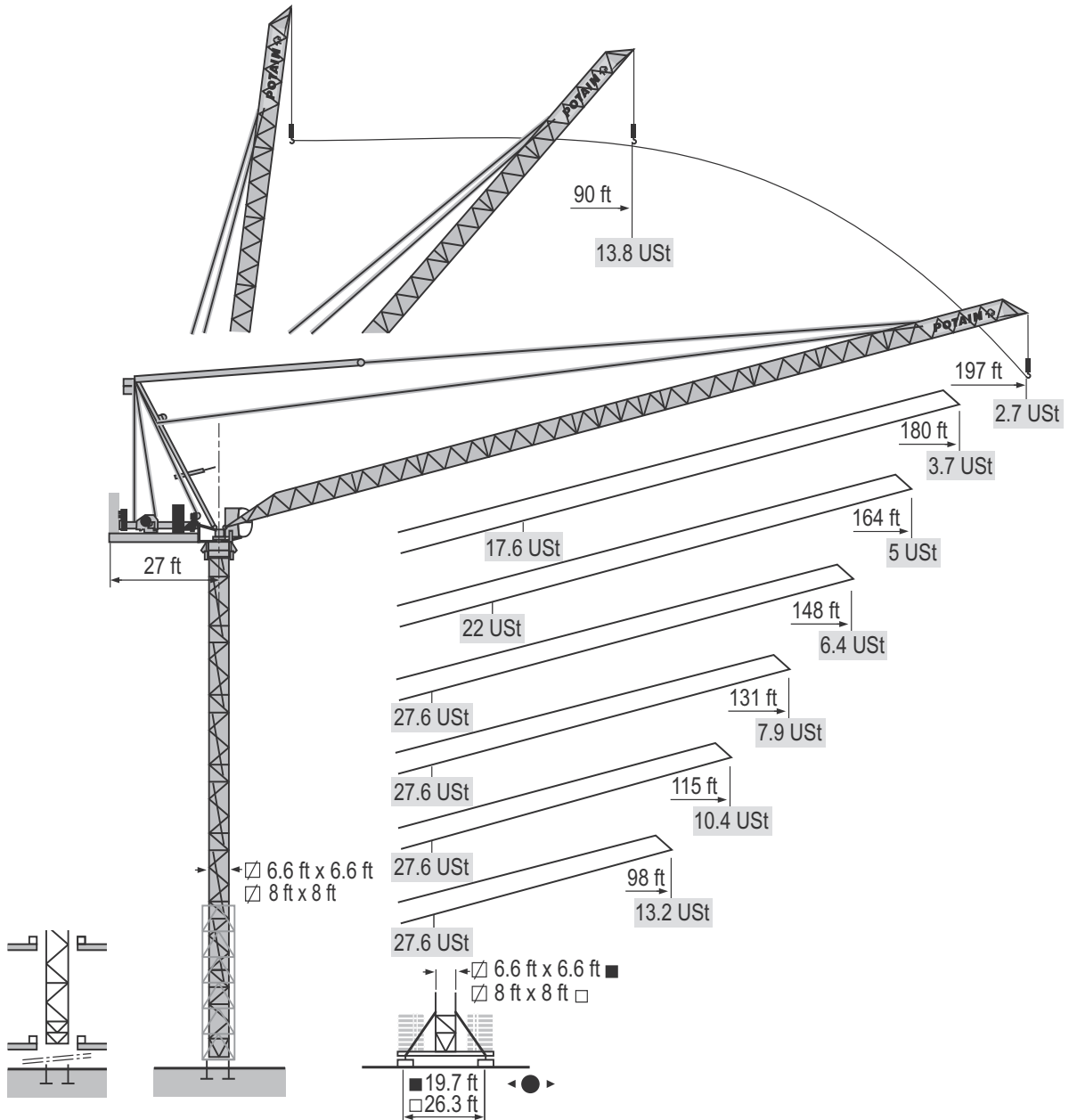

MR 295

THIS CHART IS ONLY A GUIDE AND SHOULD NOT BE USED TO OPERATE THE CRANE. The individual crane's load chart, operating instructions and other instructional plates must be read and understood prior to operating the crane.



## MR 295 H25

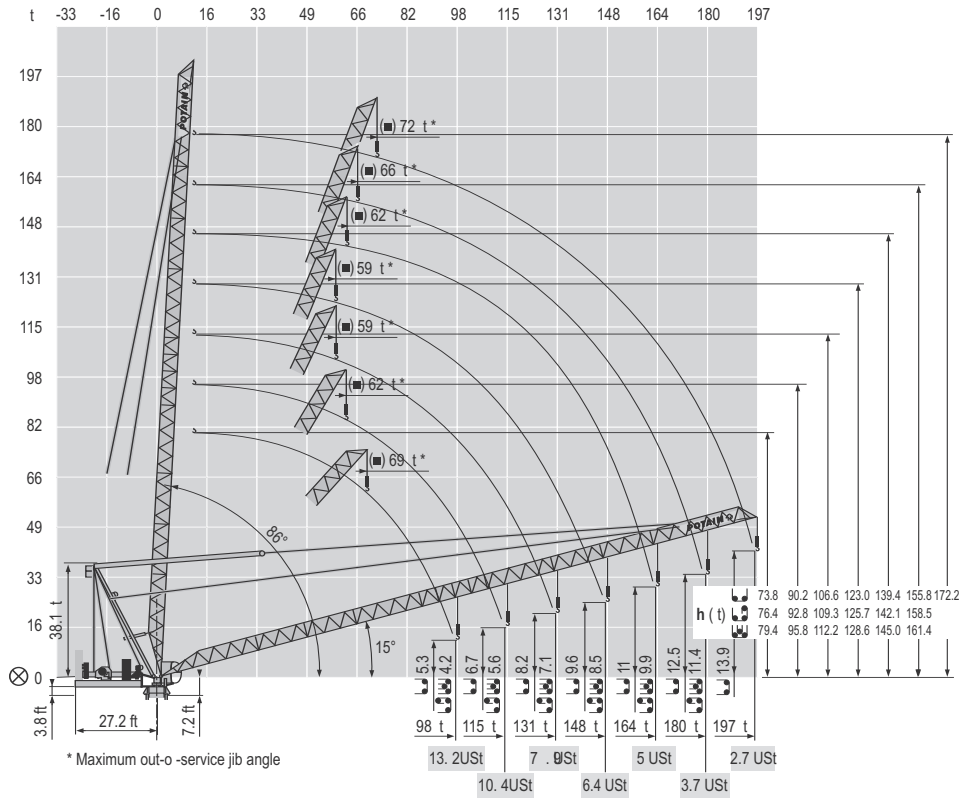

### K600 Mast

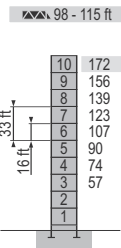

H (ft)	16 ft	11 ft
131 ft	167	9
148 ft	161	8
164 ft	156	9
180 ft	145	7
197 ft	139	8

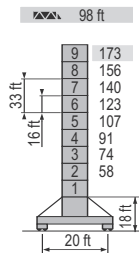

H (ft)	16 ft	11 ft
115 ft	156	8
131 ft	145	6
148 ft	135	6
164 ft	123	6
180 ft	113	4
197 ft	107	5

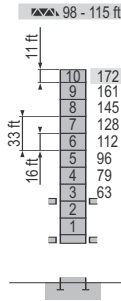

H (ft)	16 ft	11 ft
131 ft	167	8
148 ft	161	-
164 ft	156	8
180 ft	139	7
197 ft	128	7

P 62 A

V 60 A

B 60 A

### K800 Mast

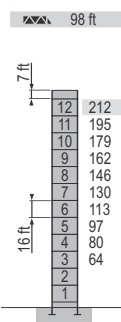

H (ft)	16 ft	11 ft
115 ft	200	10
131 ft	190	10
148 ft	184	9
164 ft	173	9
180 ft	168	8
197 ft	162	9

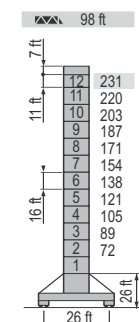

H (ft)	16 ft	11 ft
115 ft	220	11
131 ft	209	9
148 ft	203	10
164 ft	193	8
180 ft	182	8
197 ft	176	7

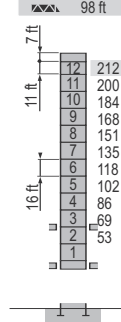

H (ft)	16 ft	11 ft
115 ft	200	11
131 ft	190	9
148 ft	184	10
164 ft	173	8
180 ft	168	9
197 ft	162	8

P 800 A

Y 800 A

B 800 B

THIS CHART IS ONLY A GUIDE AND SHOULD NOT BE USED TO OPERATE THE CRANE. The individual crane's load chart, operating instructions and other instructional plates must be read and understood prior to operating the crane.

# load charts

## MR 295 H25

16

### 3- Part Capacity

Hook Radius (ft)	Capacity (lb)						
	Jib Configuration						
	L00	L55	L50	L45	L40	L35	L30
20.0	27,558	27,558	27,558	27,558	27,558	27,558	27,558
30.0	27,558	27,558	27,558	27,558	27,558	27,558	27,558
40.0	27,558	27,558	27,558	27,558	27,558	27,558	27,558
50.0	27,558	27,558	27,558	27,558	27,558	27,558	27,558
60.0	27,558	27,558	27,558	27,558	27,558	27,558	27,558
70.0	27,558	27,558	27,558	27,558	27,558	27,558	27,558
80.0	27,558	27,558	27,558	27,558	27,558	27,558	27,558
90.0	27,082	27,307	27,463	27,558	27,558	27,558	27,558
100.0	23,175	23,722	23,942	24,408	24,718	25,380	25,834
<del>101.5</del>	22,403	23,119	23,345	23,785	24,000	24,053	<del>25,133</del>
110.0	19,817	20,302	20,582	21,023	21,104	22,340	
<del>117.5</del>	17,547	18,021	18,429	18,870	19,531	<del>19,842</del>	
120.0	16,909	17,479	17,790	18,231	18,893		
130.0	14,579	15,020	15,323	15,681	16,205		
<del>133.5</del>	13,879	14,320	14,541	15,432	<del>15,452</del>		
140.0	12,503	13,004	13,372	14,327			
<del>146.5</del>	10,900	11,572	12,341	<del>12,458</del>			
150.0	10,707	11,520	12,240				
160.0	9,531	10,404	10,515				
<del>165.5</del>	9,330	9,695	<del>8,766</del>				
170.0	8,679	8,900					
180.0	7,335	7,550					
<del>181.5</del>	7,200	<del>7,408</del>					
190.0	6,212						
<del>188.5</del>	<del>5,461</del>						
Min. Radius:	10.4	10.4	10.4	13.1	13.1	13.1	9.8

### 3- Part Capacity

Hook Radius (ft)	Capacity (lb)						
	Jib Configuration						
	L00	L55	L50	L45	L40	L35	L30
20.0	26,455	33,069	41,337	41,337	41,337	41,337	41,337
30.0	26,455	33,069	41,337	41,337	41,337	41,337	41,337
40.0	26,455	33,069	41,337	41,337	41,337	41,337	41,337
50.0	26,455	33,069	41,337	41,337	41,337	41,337	41,337
60.0	26,455	33,069	41,337	41,337	41,337	41,337	41,337
70.0	26,455	33,069	37,325	37,700	38,427	39,309	39,309
80.0	26,455	30,985	30,849	31,205	31,731	33,053	33,053
90.0	25,884	25,789	25,789	26,015	27,332	27,868	27,868
100.0	21,852	21,738	22,019	22,840	23,175	23,578	23,578
<del>101.5</del>	21,140	21,140	22,022	22,237	22,403	<del>22,818</del>	
110.0	18,494	18,378	19,200	19,480	19,817		
<del>117.5</del>	16,224	16,224	17,109	17,327	<del>17,458</del>		
120.0	15,580	15,713	16,408	16,888			
130.0	13,250	14,138	14,000	14,138			
<del>133.5</del>	12,557	13,438	13,218	<del>13,284</del>			
140.0	11,240	12,122	11,901				
<del>146.5</del>	10,141	10,357	<del>10,141</del>				
150.0	10,141	10,265					
160.0	8,700	8,531					
<del>165.5</del>	8,007	<del>7,782</del>					
170.0	7,350						
180.0	6,012						
<del>181.5</del>	<del>5,842</del>						
190.0							
<del>188.5</del>							
Min. Radius:	10.4	10.4	13.1	13.1	13.1	9.8	

MR 295

THIS CHART IS ONLY A GUIDE AND SHOULD NOT BE USED TO OPERATE THE CRANE. The individual crane's load chart, operating instructions and other instructional plates must be read and understood prior to operating the crane.

# load charts

## MR 295 H25

17

### 4-Part Capacity / 2-Part Capacity

Hook Radius (ft)	Capacity (lb)						
	Jib Configuration						
	L80	L55	L30	L45	L40	L35	L30
20.0		35,274	44,082	55,116	55,116	55,116	55,116
30.0		35,274	44,082	55,116	55,116	55,116	55,116
40.0		35,274	44,082	55,116	55,116	55,116	55,116
50.0		35,274	44,082	54,851	54,804	55,010	55,116
60.0		35,274	43,775	45,124	45,345	46,006	46,667
70.0		35,200	36,443	36,223	36,664	37,105	37,766
80.0		29,967	29,882	29,747	30,103	30,459	32,392
90.0		24,782	24,696	26,009	26,896	27,463	27,558
100.0		20,750	21,729	23,395	23,501	23,942	24,081
<b>101.8</b>		20,088	21,360	22,863	22,904	23,340	<b>23,391</b>
110.0		17,637	18,598	19,921	20,141	20,478	
<b>117.6</b>		16,445	16,445	17,768	17,800	<b>18,078</b>	
120.0		15,806	16,060	17,129	17,129		
130.0		13,476	14,662	14,579	14,662		
<b>139.5</b>		12,777	13,879	13,879	<b>13,889</b>		
140.0		11,461	12,563	12,563			
<b>146.3</b>		10,582	10,906	<b>10,662</b>			
150.0		10,582	10,767				
160.0		9,182	9,141				
<b>165.2</b>		8,448	<b>8,267</b>				
170.0		7,797					
180.0		6,453					
<b>191.0</b>		<b>6,255</b>					
190.0							
<b>196.9</b>							

Min. Radius	L80	L55	L30	L45	L40	L35	L30
	16.4	16.4	13.1	13.1	13.1	9.8	

#### Notes:

1. Bold line indicates the division between 2-part line and 4-part line.
2. Deduct 1,322 lb when using 4-part line at a radius greater than the bold line.
3. Higher 2-part capacities can be achieved if the hanging block and additional hook block are removed. (see load chart for 2-part capacity)

MR 295 H25 60 Hz		Lifting Capacity						Lifting Capacity					hp	kW	1,512 ft	
▲	150 LCC 63	ft/min	0	151	184	230	302	361	0	75	92	115	151	180		
▼		UST	13.8	9.9	6.6	3.3	1.7		27.6	19.8	13.2	6.6	3.4		150	110
▶	100 VVF 40	ft/min	1 min 40 s											100	75	
◉	RVF 182 Optima +	rpm	0 → 0.8											2 x 12	2 x 9	
⊕	<b>i</b>	ft/min	<b>i</b>											<b>i</b>	<b>i</b>	
CEI 38		IEC 38		kVA												
480 V (+6% -10%) 60 Hz		150 LCC : 300 kVA														

THIS CHART IS ONLY A GUIDE AND SHOULD NOT BE USED TO OPERATE THE CRANE. The individual crane's load chart, operating instructions and other instructional plates must be read and understood prior to operating the crane.

# metric dimensions

## MR 295 H16

18

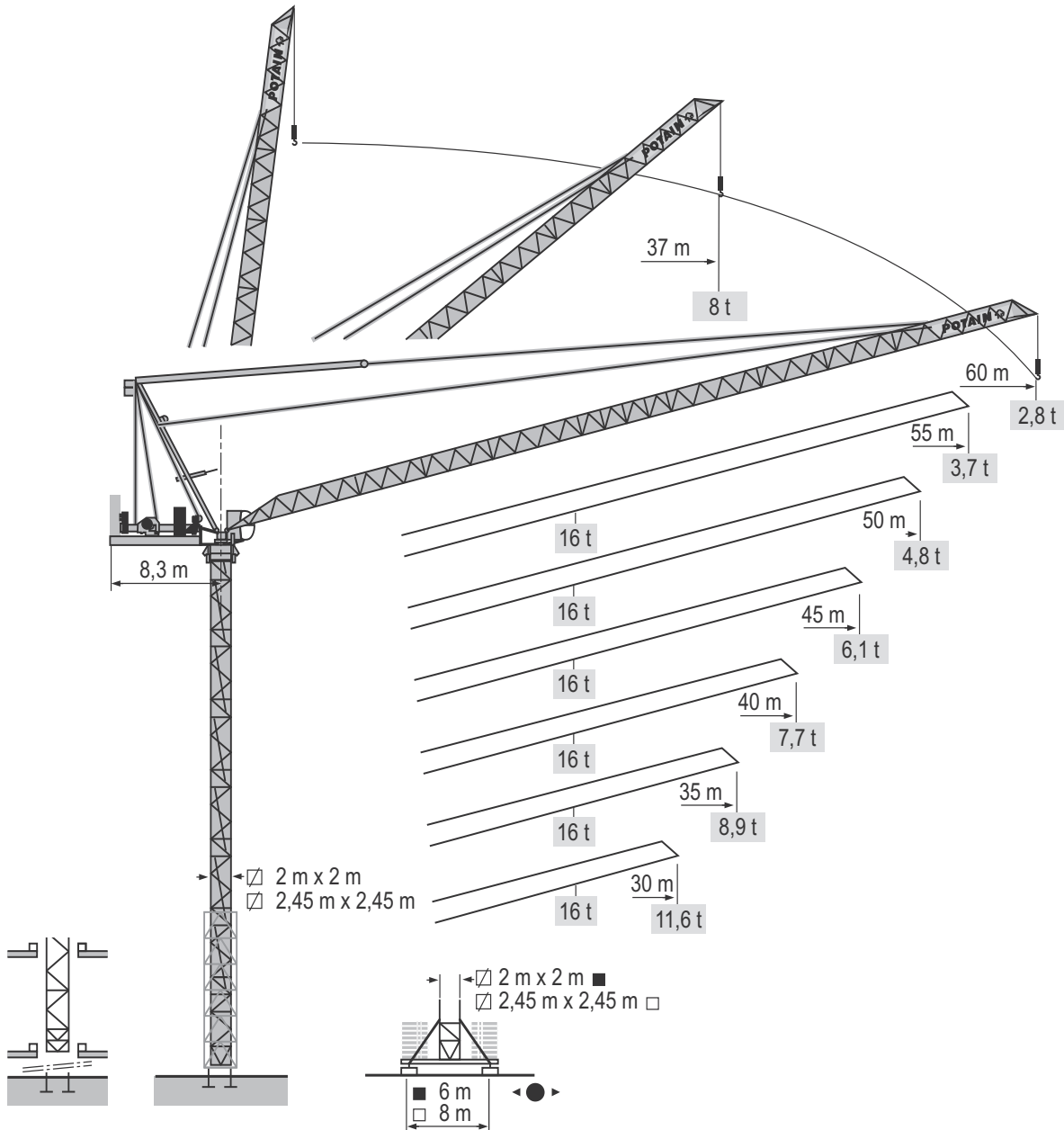

MR 295

THIS CHART IS ONLY A GUIDE AND SHOULD NOT BE USED TO OPERATE THE CRANE. The individual crane's load chart, operating instructions and other instructional plates must be read and understood prior to operating the crane.

# metric mast

## MR 295 H16

19

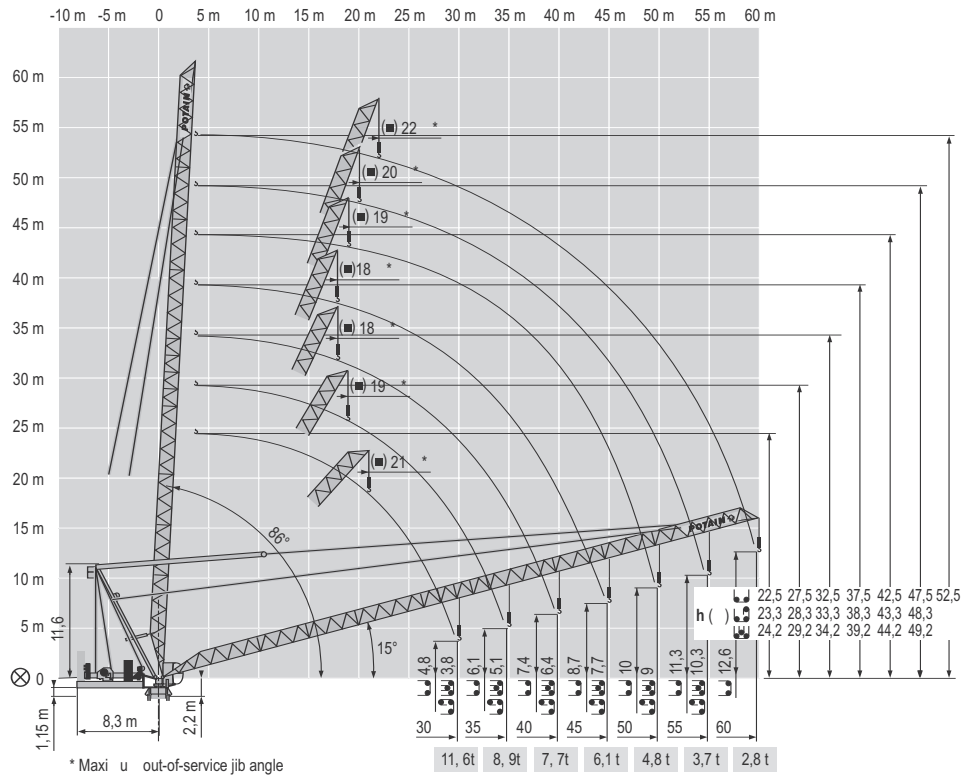

\* Maximum out-of-service jib angle

### K600 Mast

30 - 35 m

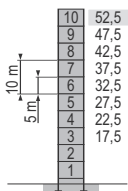

P 62 A

H (m)	5 m	3.33 m
40 m	50.8	9
45 m	49.1	8
50 m	47.5	9
55 m	44.1	7
60 m	42.5	8

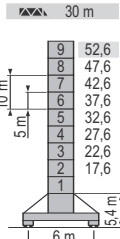

V 60 A

H (m)	5 m	3.33 m
35 m	47.6	8
40 m	44.3	6
45 m	41	6
50 m	37.6	6
55 m	34.3	4
60 m	32.6	5

30 - 35 m

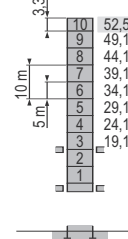

B 60 A

H (m)	5 m	3.33 m
40 m	50.8	8
45 m	49.1	9
50 m	47.5	8
55 m	42.5	7
60 m	39.1	7

### K800 Mast

30 m

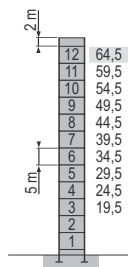

P 800 A

H (m)	5 m	3.33 m
35 m	61.1	10
40 m	57.8	10
45 m	56.1	9
50 m	52.8	9
55 m	51.1	8
60 m	49.5	9

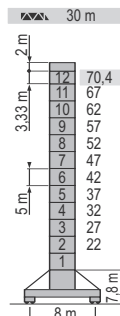

Y 800 A

H (m)	5 m	3.33 m
35 m	67	11
40 m	63.7	9
45 m	62	10
50 m	58.7	8
55 m	55.4	8
60 m	53.7	7

30 m

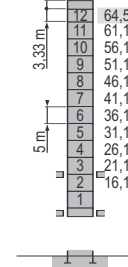

B 800 B

H (m)	5 m	3.33 m
35 m	61.1	11
40 m	57.8	9
45 m	56.1	10
50 m	52.8	8
55 m	51.1	9
60 m	49.5	8

THIS CHART IS ONLY A GUIDE AND SHOULD NOT BE USED TO OPERATE THE CRANE. The individual crane's load chart, operating instructions and other instructional plates must be read and understood prior to operating the crane.

# metric load charts

## MR 295 H16

20

### 2-Part Capacity

Hook Radius (m)	Capacity (t)						
	Jib Configuration						
	L00	L55	L50	L45	L40	L35	L30
0.10	8.00	8.00	8.00	8.00	8.00	8.00	8.00
0.14	8.00	8.00	8.00	8.00	8.00	8.00	8.00
12.19	8.00	8.00	8.00	8.00	8.00	8.00	8.00
15.24	8.00	8.00	8.00	8.00	8.00	8.00	8.00
18.29	8.00	8.00	8.00	8.00	8.00	8.00	8.00
21.34	8.00	8.00	8.00	8.00	8.00	8.00	8.00
24.38	8.00	8.00	8.00	8.00	8.00	8.00	8.00
27.43	8.00	8.00	8.00	8.00	8.00	8.00	8.00
30.48	8.00	8.00	8.00	8.00	8.00	8.00	8.00
<del>31.52</del>	8.00	8.00	8.00	8.00	8.00	8.00	<del>8.00</del>
33.53	8.00	8.00	8.00	8.00	8.00	8.00	8.00
<del>35.55</del>	8.00	8.00	8.00	8.00	8.00	<del>8.00</del>	8.00
30.58	8.00	8.00	8.00	8.00	8.00	8.00	8.00
39.02	7.05	7.31	7.51	7.61	7.81	8.00	8.00
<del>40.06</del>	0.70	7.00	7.13	7.10	<del>7.45</del>	8.00	8.00
42.07	0.10	0.40	0.50	0.73	8.00	8.00	8.00
<del>45.51</del>	5.35	5.00	5.75	<del>5.85</del>	8.00	8.00	8.00
45.72	5.28	5.50	5.08	8.00	8.00	8.00	8.00
48.77	4.55	4.85	5.15	8.00	8.00	8.00	8.00
<del>50.34</del>	4.23	4.73	<del>4.75</del>	8.00	8.00	8.00	8.00
51.82	3.94	4.30	8.00	8.00	8.00	8.00	8.00
54.80	3.33	3.73	8.00	8.00	8.00	8.00	8.00
<del>55.17</del>	3.28	<del>3.75</del>	8.00	8.00	8.00	8.00	8.00
57.91	3.10	8.00	8.00	8.00	8.00	8.00	8.00
<del>58.55</del>	<del>2.85</del>	8.00	8.00	8.00	8.00	8.00	8.00
Min. Radius:	5.0	5.0	5.0	4.0	4.0	4.0	3.0

### 3-Part Capacity

Hook Radius (m)	Capacity (t)						
	Jib Configuration						
	L00	L55	L50	L45	L40	L35	L30
0.10	12.00	12.00	12.00	12.00	12.00	12.00	12.00
0.14	12.00	12.00	12.00	12.00	12.00	12.00	12.00
12.19	12.00	12.00	12.00	12.00	12.00	12.00	12.00
15.24	12.00	12.00	12.00	12.00	12.00	12.00	12.00
18.29	12.00	12.00	12.00	12.00	12.00	12.00	12.00
21.34	12.00	12.00	12.00	12.00	12.00	12.00	12.00
24.38	12.00	12.00	12.00	12.00	12.00	12.00	12.00
27.43	11.91	12.00	12.00	12.00	12.00	12.00	12.00
30.48	10.31	10.40	10.61	10.70	11.01	11.32	11.32
<del>31.52</del>	9.99	10.19	10.29	10.40	10.69	<del>11.00</del>	11.32
33.53	8.79	8.94	9.09	9.24	9.64	10.04	10.04
<del>35.55</del>	7.77	7.90	8.06	8.40	<del>8.55</del>	9.04	9.04
30.58	7.53	7.67	7.77	8.17	8.17	8.17	8.17
39.02	6.45	6.61	7.01	7.05	7.05	7.05	7.05
<del>40.06</del>	6.10	6.23	6.63	<del>6.65</del>	6.65	6.65	6.65
42.07	5.50	5.90	6.00	6.00	6.00	6.00	6.00
<del>45.51</del>	5.00	5.20	<del>5.25</del>	5.25	5.25	5.25	5.25
45.72	5.00	5.10	5.10	5.10	5.10	5.10	5.10
48.77	4.35	4.37	4.37	4.37	4.37	4.37	4.37
<del>50.34</del>	4.03	<del>4.05</del>	4.05	4.05	4.05	4.05	4.05
51.82	3.74	3.74	3.74	3.74	3.74	3.74	3.74
54.80	3.13	3.13	3.13	3.13	3.13	3.13	3.13
<del>55.17</del>	<del>3.05</del>	3.05	3.05	3.05	3.05	3.05	3.05
57.91	3.05	3.05	3.05	3.05	3.05	3.05	3.05
<del>58.55</del>	<del>2.85</del>	2.85	2.85	2.85	2.85	2.85	2.85
Min. Radius:	5.0	5.0	4.0	4.0	4.0	3.0	3.0

MR 295

THIS CHART IS ONLY A GUIDE AND SHOULD NOT BE USED TO OPERATE THE CRANE. The individual crane's load chart, operating instructions and other instructional plates must be read and understood prior to operating the crane.



# metric load charts

## MR 295 H16

21

### 4-Part Capacity / 2-Part Capacity

Hook Radius (m)	Capacity (t)						
	Jib Configuration						
	L80	L55	L30	L45	L40	L35	L30
6.10		16.00	16.00	16.00	16.00	16.00	16.00
9.14		16.00	16.00	16.00	16.00	16.00	16.00
12.19		16.00	16.00	16.00	16.00	16.00	16.00
15.24		16.00	16.00	16.00	16.00	16.00	16.00
18.29		16.00	16.00	16.00	16.00	16.00	16.00
21.34		16.00	16.00	16.00	16.00	16.00	16.00
24.38		14.09	14.25	14.39	14.55	14.85	15.09
27.43		11.80	11.90	12.00	12.20	12.50	12.70
30.48		9.88	10.01	10.16	10.36	10.61	11.12
<b>31.02</b>		9.59	9.69	9.89	10.09	10.29	<b>10.90</b>
33.53		8.34	8.49	8.64	8.79	9.44	
<b>35.95</b>		7.74	7.91	8.00	8.20	<b>8.35</b>	
36.58		7.53	7.67	7.77	8.00		
39.62		6.45	6.61	7.15	7.25		
<b>40.68</b>		6.10	6.23	6.80	<b>6.85</b>		
42.67		5.50	6.00	6.20			
<b>45.61</b>		5.20	5.35	<b>5.95</b>			
45.72		5.20	5.28				
48.77		4.47	4.55				
<b>50.34</b>		4.13	<b>4.15</b>				
51.82		3.94					
54.86		3.23					
<b>55.17</b>		<b>3.15</b>					
57.91							
<b>60.00</b>							

Min. Radius		5.0	5.0	4.0	4.0	4.0	3.0

### Notes:

1. Bold line indicates the division between 2-part line and 4-part line.
2. Deduct 0.5 t when using 4-part line at a radius greater than the bold line.
3. Higher 2-part capacities can be achieved if the hanging block and the additional hook block are removed. (see load chart for 2-part capacity)

MR 295 H16 50 Hz - 60 Hz													ch - PS hp	kW		
	75 LVF 40 Optima	m/min t	0	34	44	76	90	0	16	17	22	38	45	75	55	637 m
	100 LVF 40 Optima	m/min t	0	8	44	56	94	116	16	22	28	47	58	100	75	1136 m
	150 LCC 40	m/min t	0	70	84	106	140	168	16	35	42	53	70	150	110	1092 m
			8	6	4	2	1	16	12	8	4	2				
	100 VVF 40	m/min	1 min 40 s										100	75		
	RVF 182 Optima +	tr/min U/min - rpm	0 → 0,8										2 x 12	2 x 9		
		m/min														
CEI 38			IEC 38					kVA								
400 V (+6% -10%) 50 Hz								75 LVF : 190 kVA 100 LVF : 220 kVA 150 LCC : 270 kVA								
480 V (+6% -10%) 60 Hz								75 LVF : 190 kVA 100 LVF : 220 kVA 150 LCC : 300 kVA								

THIS CHART IS ONLY A GUIDE AND SHOULD NOT BE USED TO OPERATE THE CRANE. The individual crane's load chart, operating instructions and other instructional plates must be read and understood prior to operating the crane.

# metric dimensions

## MR 295 H20

22

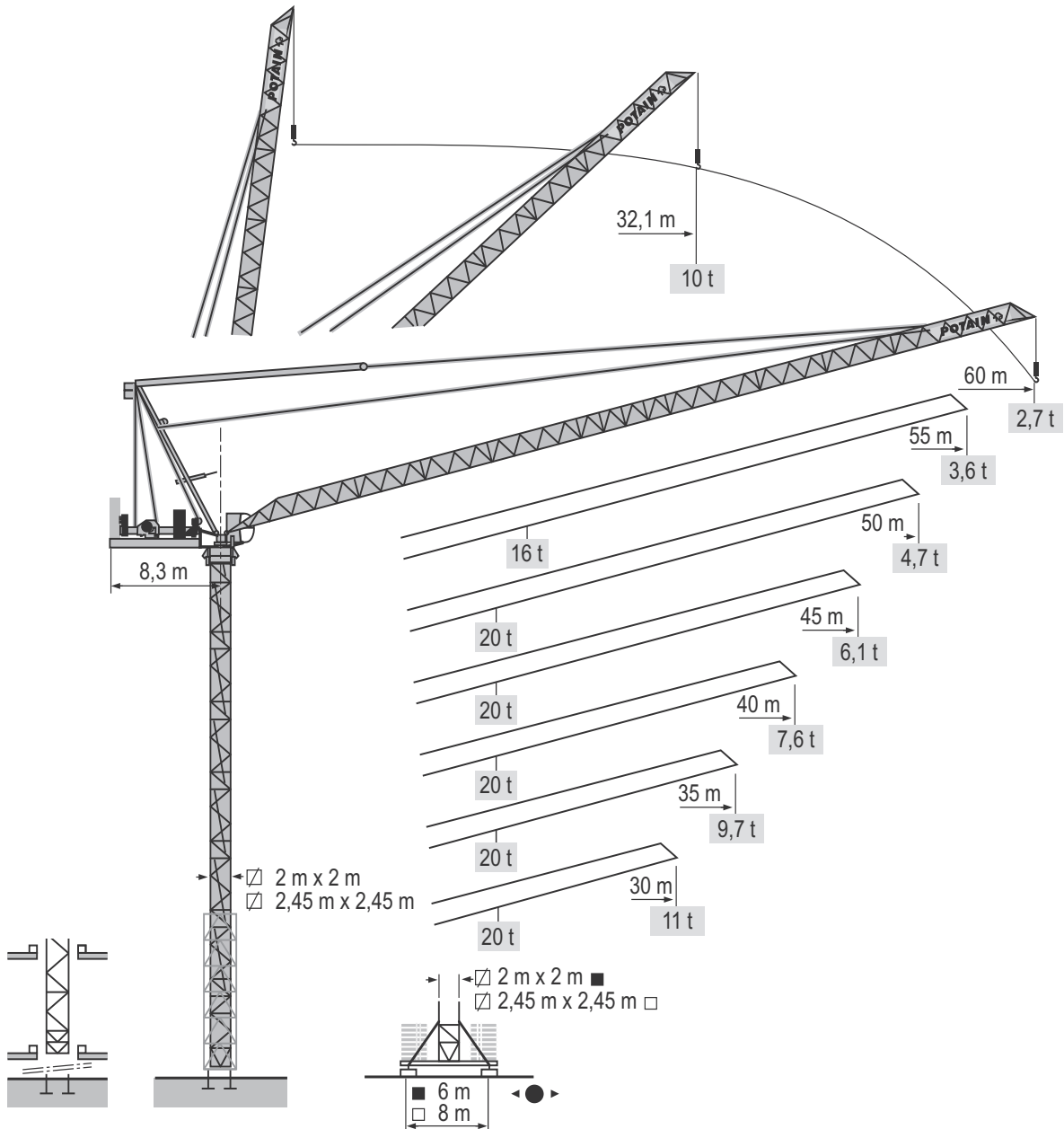

MR 295

THIS CHART IS ONLY A GUIDE AND SHOULD NOT BE USED TO OPERATE THE CRANE. The individual crane's load chart, operating instructions and other instructional plates must be read and understood prior to operating the crane.

# metric mast

## MR 295 H20

23

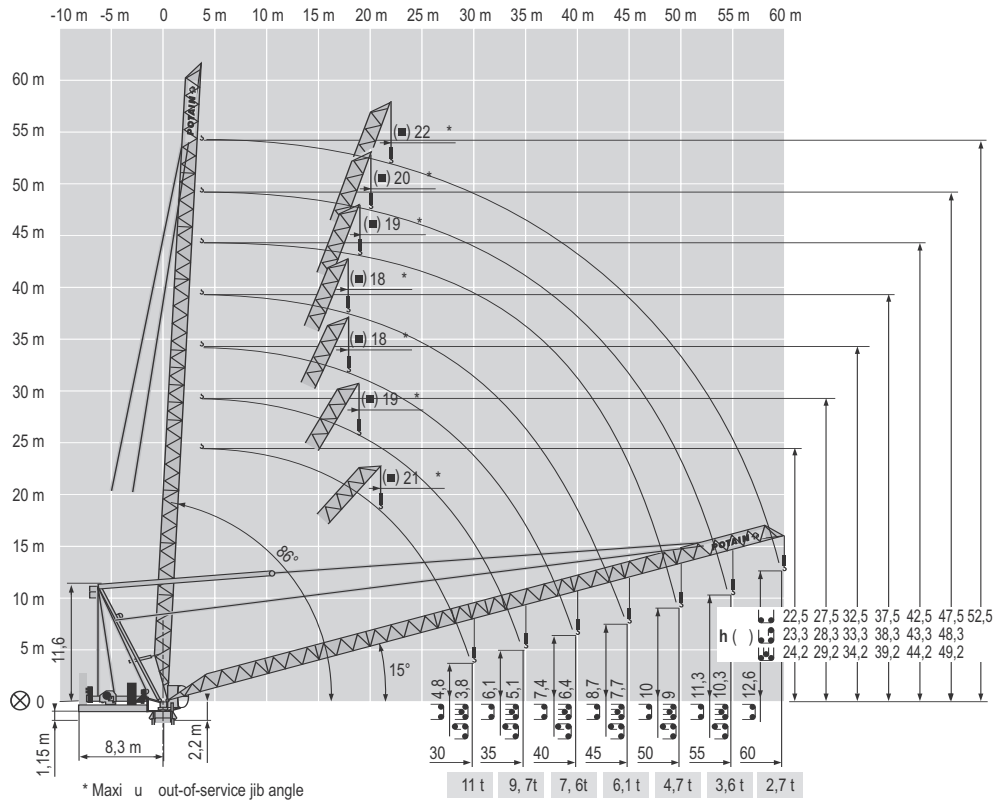

### K600 Mast

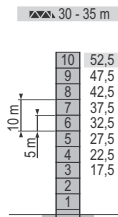

P 62 A

H (m)	5 m	3,33 m
40 m	50,8	9
45 m	49,1	8
50 m	47,5	9
55 m	44,1	7
60 m	42,5	8

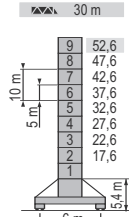

V 60 A

H (m)	5 m	3,33 m
35 m	47,6	8
40 m	44,3	6
45 m	41	6
50 m	37,6	6
55 m	34,3	4
60 m	32,6	5

### 30 - 35 m

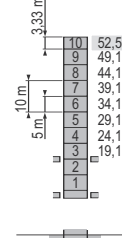

B 60 A

H (m)	5 m	3,33 m
40 m	50,8	8
45 m	49,1	9
50 m	47,5	8
55 m	42,5	7
60 m	39,1	7

### K800 Mast

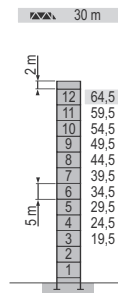

P 800 A

H (m)	5 m	3,33 m
35 m	61,1	10
40 m	57,8	10
45 m	56,1	9
50 m	52,8	9
55 m	51,1	8
60 m	49,5	9

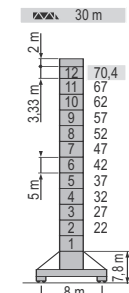

Y 800 A

H (m)	5 m	3,33 m
35 m	67	11
40 m	63,7	9
45 m	62	10
50 m	58,7	8
55 m	55,4	8
60 m	53,7	7

### 30 m

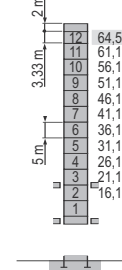

B 800 B

H (m)	5 m	3,33 m
35 m	61,1	11
40 m	57,8	9
45 m	56,1	10
50 m	52,8	8
55 m	51,1	9
60 m	49,5	8

THIS CHART IS ONLY A GUIDE AND SHOULD NOT BE USED TO OPERATE THE CRANE. The individual crane's load chart, operating instructions and other instructional plates must be read and understood prior to operating the crane.

# metric load charts

## MR 295 H20

24

### 2-Part Capacity

Hook Radius (m)	Capacity (t)						
	Jib Configuration						
	L80	L55	L50	L45	L40	L35	L30
6.10	10.00	10.00	10.00	10.00	10.00	10.00	10.00
9.14	10.00	10.00	10.00	10.00	10.00	10.00	10.00
12.19	10.00	10.00	10.00	10.00	10.00	10.00	10.00
15.24	10.00	10.00	10.00	10.00	10.00	10.00	10.00
18.29	10.00	10.00	10.00	10.00	10.00	10.00	10.00
21.34	10.00	10.00	10.00	10.00	10.00	10.00	10.00
24.38	10.00	10.00	10.00	10.00	10.00	10.00	10.00
27.43	10.00	10.00	10.00	10.00	10.00	10.00	10.00
30.48	10.00	10.00	10.00	10.00	10.00	10.00	10.00
<del>31.52</del>	10.00	10.00	10.00	10.00	10.00	10.00	<del>10.00</del>
33.53	9.34	9.44	9.50	9.79	9.89	10.00	
<del>35.55</del>	8.30	8.40	8.50	8.77	8.90	<del>9.25</del>	
36.58	8.07	8.17	8.27	8.47	8.67		
39.62	6.95	7.05	7.21	7.41	7.71		
<del>40.66</del>	6.60	6.70	6.83	7.03	<del>7.25</del>		
42.67	6.00	6.10	6.20	6.40			
<del>45.71</del>	5.25	5.35	5.50	<del>5.65</del>			
46.72	5.18	5.28	5.40				
48.77	4.45	4.57	4.97				
<del>50.84</del>	4.13	4.50	<del>4.85</del>				
51.82	3.84	4.20					
54.80	3.03	3.03					
<del>55.17</del>	3.57	<del>3.85</del>					
57.81	3.02						
<del>60.00</del>	<del>2.75</del>						
Min. Radius:	5.0	5.0	5.0	4.0	4.0	4.0	3.0

### 3-Part Capacity

Hook Radius (m)	Capacity (t)						
	Jib Configuration						
	L80	L55	L50	L45	L40	L35	L30
6.10	12.00	15.00	15.00	15.00	15.00	15.00	15.00
9.14	12.00	15.00	15.00	15.00	15.00	15.00	15.00
12.19	12.00	15.00	15.00	15.00	15.00	15.00	15.00
15.24	12.00	15.00	15.00	15.00	15.00	15.00	15.00
18.29	12.00	15.00	15.00	15.00	15.00	15.00	15.00
21.34	12.00	15.00	15.00	15.00	15.00	15.00	15.00
24.38	12.00	14.10	14.35	14.55	14.73	15.00	
27.43	11.78	11.90	12.00	12.20	12.50	12.90	
30.48	10.00	10.01	10.10	10.20	10.80	11.00	
<del>31.52</del>	9.79	9.72	9.89	10.13	10.59	<del>10.85</del>	
33.53	8.54	8.40	8.64	9.14	9.34		
<del>35.55</del>	7.50	7.50	8.03	8.10	<del>8.22</del>		
36.58	7.27	7.27	7.77	7.87			
39.62	6.21	6.55	6.61	6.71			
<del>40.66</del>	5.90	6.20	6.30	<del>6.54</del>			
42.67	5.30	5.90	5.70				
<del>45.71</del>	4.80	4.83	<del>4.85</del>				
46.72	4.80	4.78					
48.77	4.15	4.05					
<del>50.84</del>	3.73	<del>3.85</del>					
51.82	3.44						
54.80	2.87						
<del>55.17</del>	<del>2.85</del>						
57.81							
<del>60.00</del>							
Min. Radius:	5.0	5.0	4.0	4.0	4.0	3.0	

MR 295

THIS CHART IS ONLY A GUIDE AND SHOULD NOT BE USED TO OPERATE THE CRANE. The individual crane's load chart, operating instructions and other instructional plates must be read and understood prior to operating the crane.

# metric load charts

## MR 295 H20

25

### 4-Part Capacity / 2-Part Capacity

Hook Radius (m)	Capacity (t)						
	Jib Configuration						
	L00	L55	L50	L45	L40	L35	L30
0.10		10.00	20.00	20.00	20.00	20.00	20.00
0.14		10.00	20.00	20.00	20.00	20.00	20.00
12.10		10.00	20.00	20.00	20.00	20.00	20.00
15.24		10.00	20.00	20.00	20.00	20.00	20.00
18.20		10.00	19.94	19.97	20.00	20.00	20.00
21.34		10.00	10.83	10.93	17.13	17.40	18.00
24.38		13.85	13.79	13.95	14.15	14.39	14.90
27.43		11.50	11.50	11.00	11.80	12.04	13.00
30.48		9.01	9.95	10.00	10.00	10.00	11.00
<b>31.02</b>		9.29	9.89	9.99	10.00	10.39	<b>10.95</b>
33.53		8.09	8.04	8.84	9.44	9.64	
<b>35.95</b>		7.09	7.09	8.36	8.46	<b>6.60</b>	
38.58		7.37	7.48	8.07	8.17		
39.02		6.31	6.81	6.91	6.95		
<b>40.68</b>		6.00	6.50	6.53	<b>6.60</b>		
42.07		5.40	5.90	5.90			
<b>45.61</b>		5.00	5.10	<b>6.10</b>			
46.72		5.00	5.09				
48.77		4.35	4.27				
<b>50.34</b>		4.00	<b>3.90</b>				
51.82		3.64					
54.80		3.03					
<b>55.17</b>		<b>3.00</b>					
57.91							
<b>60.00</b>							

Min. Radius:	5.0	5.0	4.0	4.0	4.0	3.0
--------------	-----	-----	-----	-----	-----	-----

#### Notes:

1. Bold line indicates the division between 2-part line and 4-part line.
2. Deduct 0.5 t when using 4-part line at a radius greater than the bold line.
3. Higher 2-part capacities can be achieved if the hanging block and additional hook block are removed. (see load chart for 2-part capacity)

MR 295 H20 50 Hz - 60 Hz													ch - PS	kW			
	100 LVF 50 Optima	m/min	0	36	54	86	94	0	18	27	43	47	100	75	1018 m		
		t	10		6	3	1,9	20	12	6	3,8						
	150 LCC 50	m/min	0	58	68	86	114	138	0	29	34	43	57	69	150	110	786 m
		t	10	7,5	5	2,5	1,25	20	15	10	5	2,5					
	100 VVF 40	m/min	1 min 40 s										100	75			
	RVF 182 Optima +	tr/min U/min - rpm	0 0,8										2 x 12	2 x 9			
		m/min															
CEI 38			IEC 38					kVA									
400 V (+6% -10%) 50 Hz								100 LVF : 220 kVA 150 LCC : 270 kVA									
480 V (+6% -10%) 60 Hz								100 LVF : 220 kVA 150 LCC : 300 kVA									

MR 295

THIS CHART IS ONLY A GUIDE AND SHOULD NOT BE USED TO OPERATE THE CRANE. The individual crane's load chart, operating instructions and other instructional plates must be read and understood prior to operating the crane.

# metric dimensions

## MR 295 H25

26

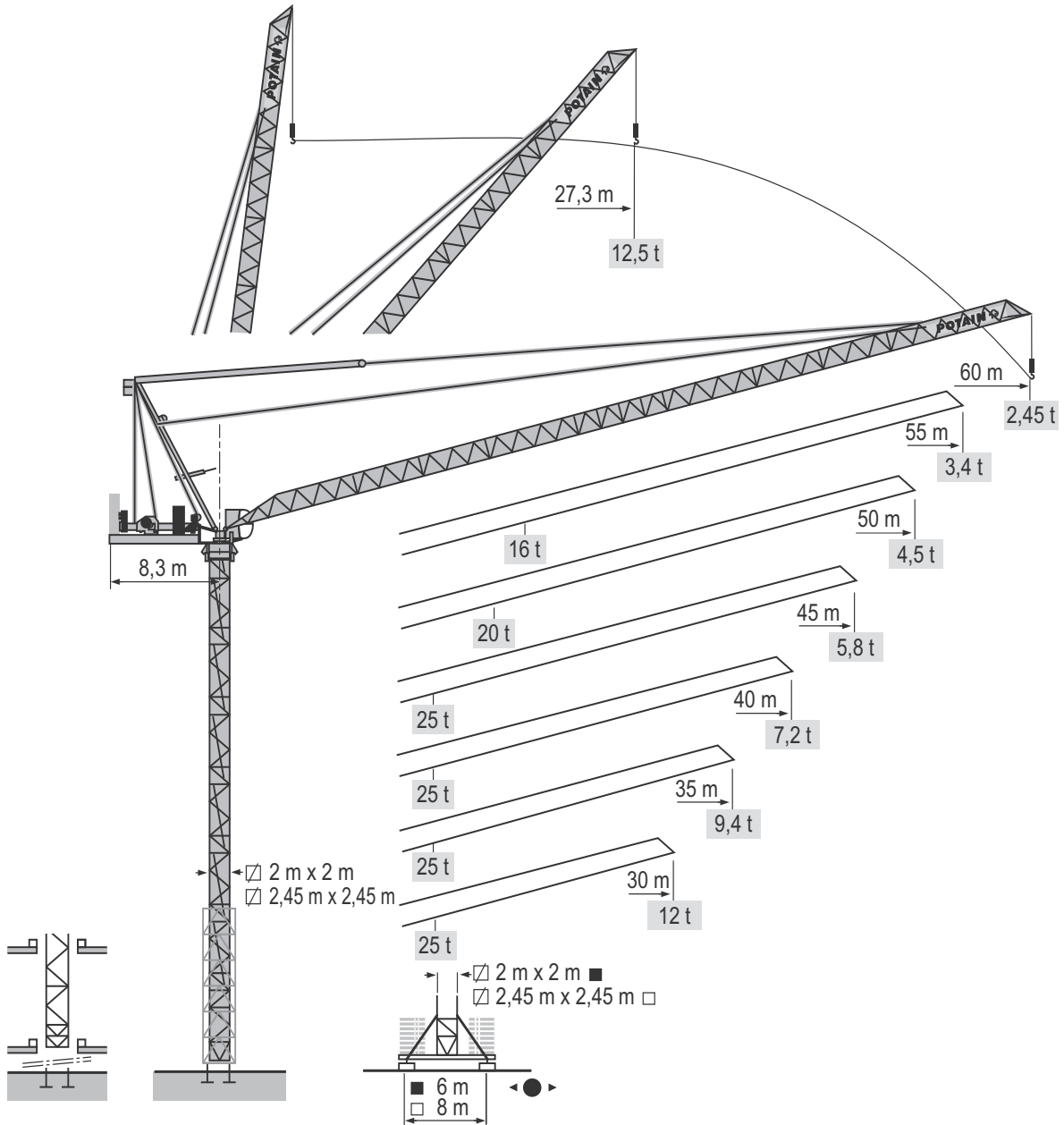

MR 295

THIS CHART IS ONLY A GUIDE AND SHOULD NOT BE USED TO OPERATE THE CRANE. The individual crane's load chart, operating instructions and other instructional plates must be read and understood prior to operating the crane.



# metric mast

## MR 295 H25

27

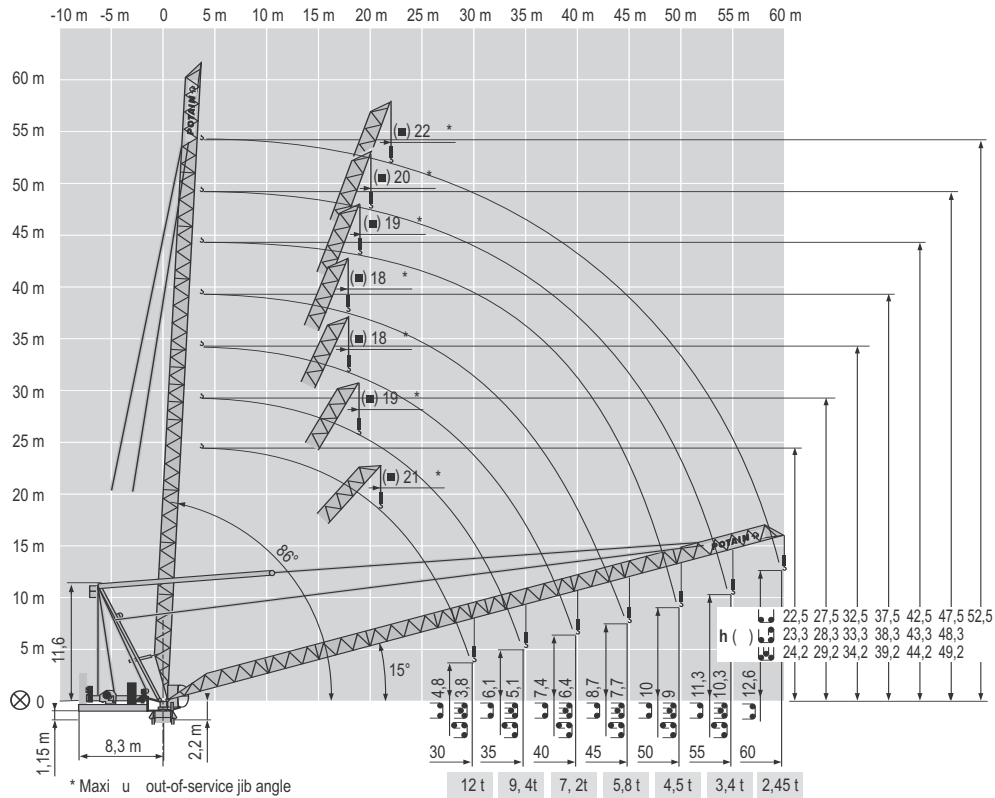

### K600 Mast

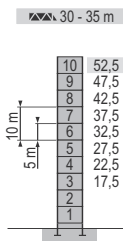

P 62 A

▲▲	H (m)	5 m	3,33 m
10	52,5	-	-
9	47,5	-	-
8	42,5	-	-
7	37,5	-	-
6	32,5	-	-
5	27,5	-	-
4	22,5	-	-
3	17,5	-	-
2	-	-	-
1	-	-	-

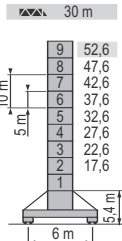

V 60 A

▲▲	H (m)	5 m	3,33 m
9	52,6	-	-
8	47,6	-	-
7	42,6	-	-
6	37,6	-	-
5	32,6	-	-
4	27,6	-	-
3	22,6	-	-
2	17,6	-	-
1	-	-	-



B 60 A

▲▲	H (m)	5 m	3,33 m
10	52,5	-	-
9	49,1	-	-
8	44,1	-	-
7	39,1	-	-
6	34,1	-	-
5	29,1	-	-
4	24,1	-	-
3	19,1	-	-
2	-	-	-
1	-	-	-

### K800 Mast

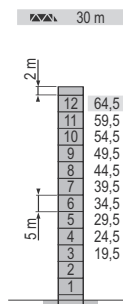

P 800 A

▲▲	H (m)	5 m	3,33 m
12	64,5	-	-
11	59,5	-	-
10	54,5	-	-
9	49,5	-	-
8	44,5	-	-
7	39,5	-	-
6	34,5	-	-
5	29,5	-	-
4	24,5	-	-
3	19,5	-	-
2	-	-	-
1	-	-	-

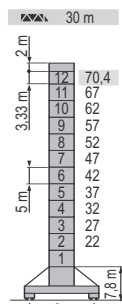

Y 800 A

▲▲	H (m)	5 m	3,33 m
12	70,4	-	-
11	67	-	-
10	62	-	-
9	57	-	-
8	52	-	-
7	47	-	-
6	42	-	-
5	37	-	-
4	32	-	-
3	27	-	-
2	22	-	-
1	-	-	-

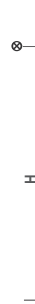

B 800 B

▲▲	H (m)	5 m	3,33 m
12	64,5	-	-
11	61,1	-	-
10	56,1	-	-
9	51,1	-	-
8	46,1	-	-
7	41,1	-	-
6	36,1	-	-
5	31,1	-	-
4	26,1	-	-
3	21,1	-	-
2	16,1	-	-
1	-	-	-

THIS CHART IS ONLY A GUIDE AND SHOULD NOT BE USED TO OPERATE THE CRANE. The individual crane's load chart, operating instructions and other instructional plates must be read and understood prior to operating the crane.

# metric load charts

## MR 295 H25

28

### 2-Part Capacity

Hook Radius (m)	Capacity (t)						
	Jib Configuration						
	L00	L55	L50	L45	L40	L35	L30
0.10	12.50	12.50	12.50	12.50	12.50	12.50	12.50
9.14	12.50	12.50	12.50	12.50	12.50	12.50	12.50
12.19	12.50	12.50	12.50	12.50	12.50	12.50	12.50
15.24	12.50	12.50	12.50	12.50	12.50	12.50	12.50
18.29	12.50	12.50	12.50	12.50	12.50	12.50	12.50
21.34	12.50	12.50	12.50	12.50	12.50	12.50	12.50
24.38	12.50	12.50	12.50	12.50	12.50	12.50	12.50
27.43	12.28	12.41	12.40	12.50	12.50	12.50	12.50
30.48	10.51	10.70	10.80	11.11	11.21	11.51	11.72
<del>31.52</del>	10.19	10.40	10.50	10.70	10.80	11.18	<del>11.40</del>
33.53	8.90	9.24	9.34	9.54	9.80	10.14	
<del>35.55</del>	7.90	8.17	8.30	8.50	8.80	<del>9.00</del>	
36.58	7.07	7.93	8.07	8.27	8.57		
39.62	6.61	6.81	6.95	7.11	7.35		
<del>40.66</del>	6.30	6.50	6.60	7.00	<del>7.00</del>		
42.67	5.70	5.90	6.07	6.50			
<del>45.71</del>	4.95	5.25	5.60	<del>5.55</del>			
45.72	4.88	5.23	5.50				
48.77	4.32	4.75	4.77				
<del>50.81</del>	4.23	4.40	<del>4.40</del>				
51.82	3.94	4.04					
54.86	3.33	3.43					
<del>55.17</del>	3.27	<del>3.40</del>					
57.91	2.82						
<del>60.66</del>	<del>2.45</del>						
Min. Radius	5.0	5.0	5.0	4.0	4.0	4.0	3.0

### 3-Part Capacity

Hook Radius (m)	Capacity (t)						
	Jib Configuration						
	L00	L55	L50	L45	L40	L35	L30
0.10		12.00	15.00	18.75	18.75	18.75	18.75
9.14		12.00	15.00	18.75	18.75	18.75	18.75
12.19		12.00	15.00	18.75	18.75	18.75	18.75
15.24		12.00	15.00	18.75	18.75	18.75	18.75
18.29		12.00	15.00	18.75	18.75	18.75	18.75
21.34		12.00	15.00	16.93	17.13	17.43	17.83
24.38		12.00	14.05	13.90	14.15	14.30	14.60
27.43		11.74	11.70	11.70	11.80	12.40	12.64
30.48		9.91	9.80	10.20	10.30	10.51	10.60
<del>31.52</del>		9.59	9.50	9.90	10.00	10.19	<del>10.55</del>
33.53		8.39	8.34	8.74	8.84	8.90	
<del>35.55</del>		7.30	7.30	7.70	7.80	<del>7.91</del>	
36.58		7.07	7.13	7.47	7.57		
39.62		6.61	6.41	6.35	6.41		
<del>40.66</del>		5.70	6.10	6.00	<del>6.00</del>		
42.67		5.10	5.50	5.40			
<del>45.71</del>		4.60	4.70	<del>4.80</del>			
45.72		4.60	4.60				
48.77		3.95	3.87				
<del>50.81</del>		3.63	<del>3.55</del>				
51.82		3.34					
54.86		2.73					
<del>55.17</del>		<del>2.85</del>					
57.91							
<del>60.66</del>							
Min. Radius	5.0	5.0	4.0	4.0	4.0	3.0	

MR 295

THIS CHART IS ONLY A GUIDE AND SHOULD NOT BE USED TO OPERATE THE CRANE. The individual crane's load chart, operating instructions and other instructional plates must be read and understood prior to operating the crane.

# metric load charts

## MR 295 H25

29

### 4-Part Capacity / 2-Part Capacity

Hook Radius (m)	Capacity (t)						
	Jib Configuration						
	L60	L55	L50	L45	L40	L35	L30
6.10		16.00	20.00	25.00	25.00	25.00	25.00
9.14		16.00	20.00	25.00	25.00	25.00	25.00
12.19		16.00	20.00	25.00	25.00	25.00	25.00
15.24		16.00	20.00	24.88	24.80	24.85	25.00
18.29		16.00	19.88	20.47	20.57	20.87	21.17
21.34		15.97	18.53	16.43	16.68	16.83	17.13
24.38		13.39	13.55	13.49	13.65	13.82	14.69
27.43		11.24	11.20	11.80	12.20	12.46	12.90
30.48		9.41	9.86	10.61	10.68	10.86	10.92
<b>31.02</b>		9.09	9.69	10.29	10.39	10.59	<b>10.91</b>
33.53		8.00	8.44	9.04	9.14	9.29	
<b>35.55</b>		7.46	7.46	8.06	8.07	<b>8.20</b>	
36.58		7.17	7.28	7.77	7.77		
39.62		6.11	6.65	6.61	6.65		
<b>40.68</b>		5.80	6.30	6.30	<b>6.90</b>		
42.67		5.20	5.70	5.70			
<b>45.61</b>		4.80	4.95	<b>4.95</b>			
45.72		4.80	4.88				
48.77		4.17	4.15				
<b>50.34</b>		3.88	<b>3.75</b>				
51.82		3.54					
54.86		2.93					
<b>55.17</b>		<b>2.95</b>					
57.91							
<b>60.00</b>							

Min. Radius		5.0	5.0	4.0	4.0	4.0	3.0

### Notes:

1. Bold line indicates the division between 2-part line and 4-part line.
2. Deduct 0.6t when using 4-part line at a radius greater than the bold line.
3. Higher 2-part capacities can be achieved if the hanging block and additional hook block are removed. (see load chart for 2-part capacity)

MR 295 H25 50 Hz - 60 Hz													ch - PS hp	kW				
	150 LCC 63	m/min	0	46	56	70	92	110	0	23	28	35	46	55	150	110	461 m	
		t	12,5	9	6	3	1,56	25	18	12	6	3,12						
	100 VVF 40	m/min	1 min 40 s															
	RVF 182 Optima +	tr/min U/min - rpm	0 0,8														2 x 12	2 x 9
		m/min																
CEI 38		IEC 38		<b>kVA</b>														
400 V (+6% -10%) 50 Hz				150 LCC : 270 kVA														
480 V (+6% -10%) 60 Hz				150 LCC : 300 kVA														

THIS CHART IS ONLY A GUIDE AND SHOULD NOT BE USED TO OPERATE THE CRANE. The individual crane's load chart, operating instructions and other instructional plates must be read and understood prior to operating the crane.

# symbols glossary

30



Anchor Steel



Counter Jib



Jib



Travelling



Area marker



One or Shaped Base



Jib Extension



Travelling Trolley



Ballast



Crane Trestle Travelling Equipment



Hoist



Travelling Trolley & Load Diagram



Cab



Electrical Requirement



Reeling 2-Part



Trolley



Chassis



Hoist



Reeling 4-part



Climbing Equipment



Hoisting Hook/chain



Straight Trestle Travelling Equipment



Controls



Hydraulic Equipment



Trolley



## Regional Headquarters

### Americas

Manitowoc, Wisconsin, USA

Tel: +1 920 684 6621

Fax: +1 920 683 6278

Shady Grove, Pennsylvania, USA

Tel: +1 717 597 8121

Fax: +1 717 597 4062

## Regional Offices

### Americas

#### Brazil

Alphaville

Tel: +55 11 3103 0200

Fax: +55 11 4688 2013

#### Mexico

Monterrey

Tel: +52 81 8124 0128

Fax: +52 81 8124 0129

### Europe, Middle East, Africa

#### Algeria

Hydra

Tel: +21 3 21 48 1173

Fax: +21 3 21 48 1454

#### Czech Republic

Netvorice

Tel: +420 317 78 9313

Fax: +420 317 78 9314

#### France

Baudemont

Tel: +33 385 28 2589

Fax: +33 385 28 0430

Cergy

Tel: +33 130 31 3150

Fax: +33 130 38 6085

Decines

Tel: +33 472 81 5000

Fax: +33 472 81 5010

#### Germany

Langenfeld

Tel: +49 21 73 8909-0

Fax: +49 21 73 8909 30

#### Hungary

Budapest

Tel: +36 13 39 8622

Fax: +36 13 39 8622

#### Italy

Parabiago

Tel: +390 331 49 3311

Fax: +390 331 49 3330

### Europe, Middle East, Africa

Ecully, France

Tel: +33 472 18 2020

Fax: +33 472 18 2000

#### Netherlands

Breda

Tel: +31 76 578 3999

Fax: +31 76 578 3978

#### Poland

Warsaw

Tel: +48 22 843 3824

Fax: +48 22 843 3471

#### Portugal

Alfena

Tel: +351 229 69 8840

Fax: +351 229 69 8848

Lisbon

Tel: +351 212 109 340

Fax: +351 212 109 349

#### Russia

Moscow

Tel: +7 495 641 2359

Fax: +7 495 641 2358

#### U.A.E.

Dubai

Tel: +971 4 3381 861

Fax: +971 4 3382 343

#### U. K.

Middlesex

Tel: +44 1 895 43 0053

Fax: +44 1 895 45 9500

Sunderland

Tel: +44 191 522 2000

Fax: +44 191 522 2052

### Asia – Pacific

#### Australia

Melbourne

Tel: +61 3 9 336 1300

Fax: +61 3 9 336 1322

Sydney

Tel: +61 2 9 896 4433

Fax: +61 2 9 896 3122

### Asia – Pacific

Shanghai, China

Tel: +86 21 51113579

Fax: +86 21 51113578

Singapore

Tel: +65 6264 1188

Fax: +65 6862 4142

#### China

Beijing

Tel: +86 10 58674761

Fax: +86 10 58674760

Xi'an

Tel: +86 29 87891465

Fax: +86 29 87884504

#### Korea

Seoul

Tel: +82 2 3439 0400

Fax: +82 2 3439 0405

#### Philippines

Makati City

Tel: +63 2 844 9437

Fax: +63 2 844 4712

#### Factories

Brazil

Alphaville

China

Zhangjiagang

France

Charlieu

La Clayette

Moulins

Germany

Wilhelmshaven

India

Calcutta

Pune

Italy

Niella Tanaro

Portugal

Baltar

Fânzeres

Slovakia

Saris

U.S.A.

Manitowoc

Port Washington

Shady Grove

Constant improvement and engineering progress make it necessary that we reserve the right to make specification, equipment and price changes without notice. Illustrations shown may include optional equipment and accessories, and may not include all standard equipment.