



Upper Machinery

UPPER FRAME: All-welded, stress relieved, precision machined unit, machinery side housing bolted to upper frame.

TURNTABLE BEARING WITH INTEGRAL RING GEAR:

Outer bearing race with integral, external swing (ring) gear bolted to lower frame; inner bearing race bolted to upper revolving frame. A machined surface is provided for mounting turntable bearing.

CONTROL SYSTEM: "Speed-O-Matic" power hydraulic system that includes a gear pump to provide a constant flow of oil, an accumulator to maintain operating pressure and variable pressure control valves to regulate this pressure to all the clutches, and to release swing and boomhoist brake.

CLUTCHES: "Speed-O-Matic" power hydraulic actuated, internal expanding, 2-cylinder, 2-shoe type for all functions. Clutches are interchangeable.

DRUMS: Front and rear main, and optional third, operating drums.

Drum laggings --- 2-piece, removable; bolted to brake drum which is involute splined to drum shaft mounted in line bores on ball bearing.

Brakes --- External contracting band; mechanically foot pedal operated, with locking latch.

Automatic brake --- Optional extra; available on both front and rear main drums, as additional to standard.

INDEPENDENT BOOMHOIST: Spur gear driven with precision boom raising and lowering through the clutches.

Drum --- Involute-splined to shaft, with brake drum and drum with locking ratchet wheel cast integral.

Brake --- External contracting band, spring applied and power hydraulically released.

Lock --- Mechanically controlled drum locking pawl.

SWING: Spur gear driven; 2 sets of clutches transmit swing power smoothly into the swing pinion. Swing pinion meshes with external teeth of swing gear integral with outer race of turntable bearing.

Brake --- Two-directional, external contracting band, spring applied, power hydraulically released. Brake drum is involute-splined to swing shaft directly.

Lock --- Mechanically controlled drop pin.

Speed --- 3-speed; 3.4rpm (high)/2.2rpm (mid.)/1.1 rpm (low).

Independent swing/travel --- Standard.

GANTRY: Retractable high gantry.

OPERATOR'S CAB: Full-vision compartment with safety glass panels, separated from upper machinery with an inside door.

COUNTERWEIGHT: Removable, mounted on rear of upper revolving frame.

POWER UNITS:

	Standard	Optional extra
Make & Model	Mitsubishi 6D14CT	Cat 3304T
Type	Water-cooled, 4-cycle, turbo-charged, diesel engine	Water-cooled, 4-cycle, turbo-charged, diesel engine
No. of cylinders	6	4
Bore & Stroke	110 x 115 mm	121 x 152 mm
Displacement	6,557 cc	6,990 cc
Rated output	130 PS/ 2,000 r.p.m.	130 PS/ 2,000 r.p.m.
Maximum torque	51 kg-m/ 1,400 r.p.m.	52 kg-m/ 1,000 r.p.m.
Fuel tank	250 liters	250 liters
3-speed transmission	Power shift type	Power shift type
Speed increase pinion	Optional extra for all of speed function	Optional extra; for all of speed function

Lower Machinery

LOWER FRAME: All-welded, stress relieved, precision machined, line boared for horizontal traction shaft.

TRACK ROLLERS: Heat treated, all rollers mounted on bushes with floating seals requiring no further lubrication.

TRACK SHOES: Heat treated, self-cleaning, multiple hinged shoes.

SHOE WIDTH: 760 mm --- Standard.

915 mm --- Optional extra.

POWER HYDRAULIC STEER/TRAVEL: For travel or steer, jaw clutches of traction shaft are power hydraulically engaged with jaws on brake drums, automatically releasing spring-applied steer/digging brakes. Brakes are external contracting band type.

TRAVEL SPEED: 1.25 km/h (high) - 0.8 km/h (mid.) - 0.4 km/h (low).

SIDE FRAMES: Side frames can be extended or retracted by two power hydraulic cylinders and are removable, leaving track drive chains connected.

General Dimensions

- A: Height of high gantry
 - raised 4.850m
 - lowered (for transporting) 3.260m
- B: Height of low gantry 3.260m
- C: Height of cab 2.985m
- D: Counterweight ground clearance
 - (with counterweight "A" + "B") 1.065m
- E: Radius of rear end
 - (with counterweight "A" + "B") 4.200m
- F: Center of rotation to boom foot pin 0.940m
- G: Center to center distance of tumbler 4.740m
- H: Overall length of crawler 5.600m
- I: Height from ground to boom foot pin 1.590m
- J: Overall width of cab 2.830m
- K: Ground clearance 0.335m
- L: Center to center distance of crawler
 - (with 760mm shoe) extended 3.590m
 - retracted 2.540m
- M: Overall width of crawler
 - (with 760mm shoe) extended 4.350m
 - retracted 3.300m

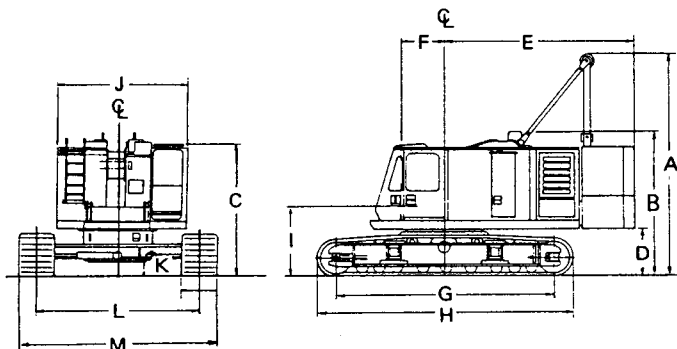

Change of name

The current LS-118RM name has been changed to SC 500M.

We are constantly improving our products and therefore reserve the right to change designs and specifications without notice.

SUMITOMO (S.H.I.) CONSTRUCTION MACHINERY CO., LTD.



CRANE BOOMS: Lattice construction; round tubular main chords, alloy, hi-ten steel, with bracing of round steel tubing.

- Boom connections In-line pin connections.
- Basic boom Two-piece, 12.20 m basic length; 6.10 m long base and top sections; 1.20 m deep and 1.27 m wide at connections.
- Boom point machinery Five head sheaves mounted on antifriction bearings.
- Boom extensions (optional extra) Available in 3.05 m, 6.10 m and 9.15 m lengths with pendants.
- Maximum boom length 51.85 m.
- Basic fly jib (optional extra) Two-piece; 6.10 m basic length with 3.05 m long base and top sections.
- Fly jib extension (optional extra) Available in 3.05 m length.
- Maximum fly jib length 15.25 m.
- Boom plus fly jib length 42.70m + 6.10m.
42.70m + 9.15m.
42.70m + 12.20m.
42.70m + 15.25m (max.).
- Auxiliary jib (optional extra) Available for auxiliary crane hoist; mounted on top section of basic boom.

HOOK BLOCK:

- 50 t, four sheaves Standard.
- 15 t Optional extra.
- 5 t Standard for fly jib and/or auxiliary jib.

BOOM HOIST ASSEMBLY: With power lowering clutch.

- 14-part boom hoist reeving Standard.
- Boom hoist line speed (raising) @40m/min(high)/26m/min(mid.)/13m/min(low).
- Boom hoist line speed (lowering) @32m/min(high)/21m/min(mid.)/11m/min(low).

LINE PULL AND LINE SPEED:

Drums	Root dia.	Type	Line pull	Line speed	Cable dia.
Front (main hoist)	380 mm	parallel grooved	11,000kg with 'high' line speed	hoisting: @ 50 m/min (high) @ 33 m/min (mid.) @ 17 m/min (low)	20 mm
Rear (aux. hoist)	380 mm	parallel grooved	12,500 kg with 'mid.' and 'low' line speeds	lowering: @ 40 m/min (high) @ 26 m/min (mid.) @ 13 m/min (low)	20 mm

(Available line pull – Not based on wire rope strength)

HOIST REEIVING:

No. of part line	Main hoist									Aux. hoist
	9	8	7	6	5	4	3	2	1	1
Max. load (t)	50.0	44.8	39.2	33.6	28.0	22.4	16.8	11.2	5.6	5.0

GANTRY: High gantry.

WORKING WEIGHT AND GROUND PRESSURE:

Shoe width	Weight	Pressure
760mm	46.0 t	0.60 kg/cm ²
915mm	47.2 t	0.51 kg/cm ²

With basic boom and counterweight "A" + "B".

COUNTERWEIGHT:

"A" (6,800 kg) + "B" (7,000 kg)

POWER LOAD LOWERING CLUTCH:

- On front drum Standard.
- On rear drum Optional extra.

SAFETY DEVICES: Hook over hoist alarm, boom hoist limiting device, boom angle indicator, boom back stop.

GRADEABILITY: 30% (17°) without c.t.w.t "A". "B" and boom attachment.

LOAD MOMENT ALARM/INDICATOR: Optional extra.

MID-POINT CABLE: Required for boom length 45.75 m or longer.

CABLES:

- For main hoist 6 x WS(26) IWRC, 20 mm dia.; breaking load 31 t (JIS rated)
- For boom hoist 6 x WS(26) IWRC, 16 mm dia.; breaking load 19.1 t (JIS rated)
- For aux. hoist (optional extra) 6 x WS(26) IWRC, 20 mm dia.; breaking load 31 t (JIS rated)

We are constantly improving our products and therefore reserve the right to change designs and specifications without notice.

SUMITOMO (S.H.I.) CONSTRUCTION MACHINERY CO., LTD.

LS-118RM CRANE CAPACITIES: With side frames fully extended

(in metric tons)

Working radius (m)	Boom length (m)													
	12.20	15.25	18.30	21.35	24.40	27.45	30.50	33.55	36.60	39.65	42.70	45.75	48.80	51.85
3.7	50.0													
4.0	43.7	37.5/4.4												
4.5	36.5	36.4												
5.0	30.9	30.8	30.7											
5.5	26.5	26.4	26.3	25.4/5.6										
6.0	23.6	23.5	23.4	23.3	22.1/6.2	18.7/6.8								
7.0	18.6	18.5	18.4	18.3	18.2	18.1	16.8/7.4							
8.0	15.4	15.3	15.2	15.1	15.0	15.0	14.9	14.8	13.1/8.6					
9.0	13.2	13.1	13.0	12.9	12.8	12.7	12.6	12.5	12.5	12.0/9.2	10.8/9.8			
10.0	11.6	11.5	11.4	11.3	11.2	11.1	11.0	10.9	10.8	10.7	10.6	10.0/10.4	9.0/11.0	
12.0	10.0/11.6	9.1	9.0	8.9	8.8	8.7	8.6	8.5	8.4	8.3	8.2	8.1	8.0	7.9
14.0		7.5	7.5	7.4	7.3	7.2	7.1	7.0	7.0	6.9	6.8	6.6	6.5	6.4
16.0		7.4/14.3	6.3	6.2	6.1	6.0	5.9	5.8	5.8	5.7	5.6	5.5	5.4	5.3
18.0			5.7/17.0	5.2	5.1	5.0	5.0	4.9	4.9	4.8	4.7	4.6	4.5	4.4
20.0				4.7/19.6	4.5	4.4	4.3	4.2	4.2	4.1	4.0	3.9	3.8	3.7
22.0					3.9	3.8	3.7	3.6	3.6	3.5	3.4	3.3	3.2	3.1
24.0					3.7/22.2	3.3	3.2	3.1	3.1	3.0	2.9	2.8	2.7	2.6
26.0						2.8/24.9	2.7	2.6	2.6	2.5	2.5	2.4	2.3	2.2
28.0							2.6/27.5	2.4	2.4	2.3	2.2	2.1	2.0	1.9
30.0								2.1	2.1	2.0	1.9	1.8	1.7	1.6
32.0									1.7	1.6	1.5	1.4	1.3	1.2
34.0										1.6/32.7	1.4	1.3	1.2	1.0

(CBM00135A)

Notes:

- Capacities shown are in metric tons and are based on 75% of minimum tipping loads—over the side—with machine standing level on firm supporting surface under ideal job conditions. Deductions from the lifting crane capacities must be made for weight of hook block.

Kind of hook block	50 t	15 t	5 t
Weight of hook block (t)	0.75	0.3	0.12

- When operating off the main boom peak sheaves with jib on boom, the following deductions in machine lifting capacities must be made;

Jib length (m)	6.10	9.15	12.20	15.25
Weight to be deducted (t)	0.8	0.9	1.0	1.1

LS-118RM JIB CAPACITIES:

(in metric tons)

Jib length (m)	Jib angle		
	0°	15°	30°
6.10	5.0	4.5	3.6
9.15	4.5	3.6	2.8
12.20	3.6	2.6	1.8
15.25	2.1	1.5	N.A.

Notes: Determining machine jib capacities.

- The jib capacities are equal to the crane lifting capacities of the main boom on which the jib is fixed except that they are restricted by the maximum jib capacities shown above.
- The jib angle to boom must not exceed 30° when lifting.
- Available boom length to fix jib of all length is from 24.40 to 42.70 m.

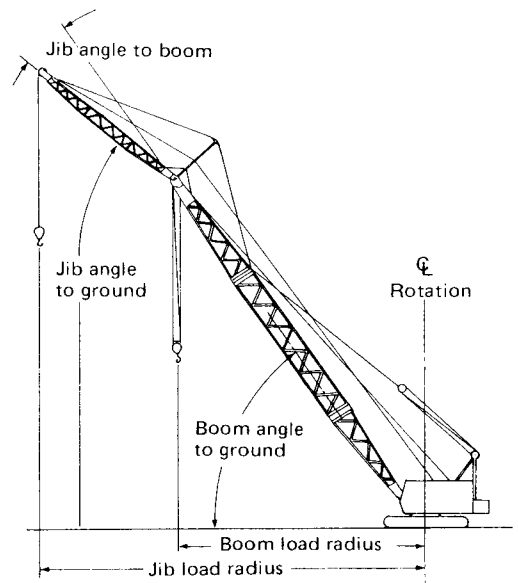

Crane 50 metric tons



LS-118RM CRANE WORKING RANGES:

