

# CCH9000EX

Max. Lifting Capacity : 90t  
 Max. Boom Length : 61m  
 Max. Jib Combination : 46m + 22m

## General dimensions (with basic boom) (Unit : mm)

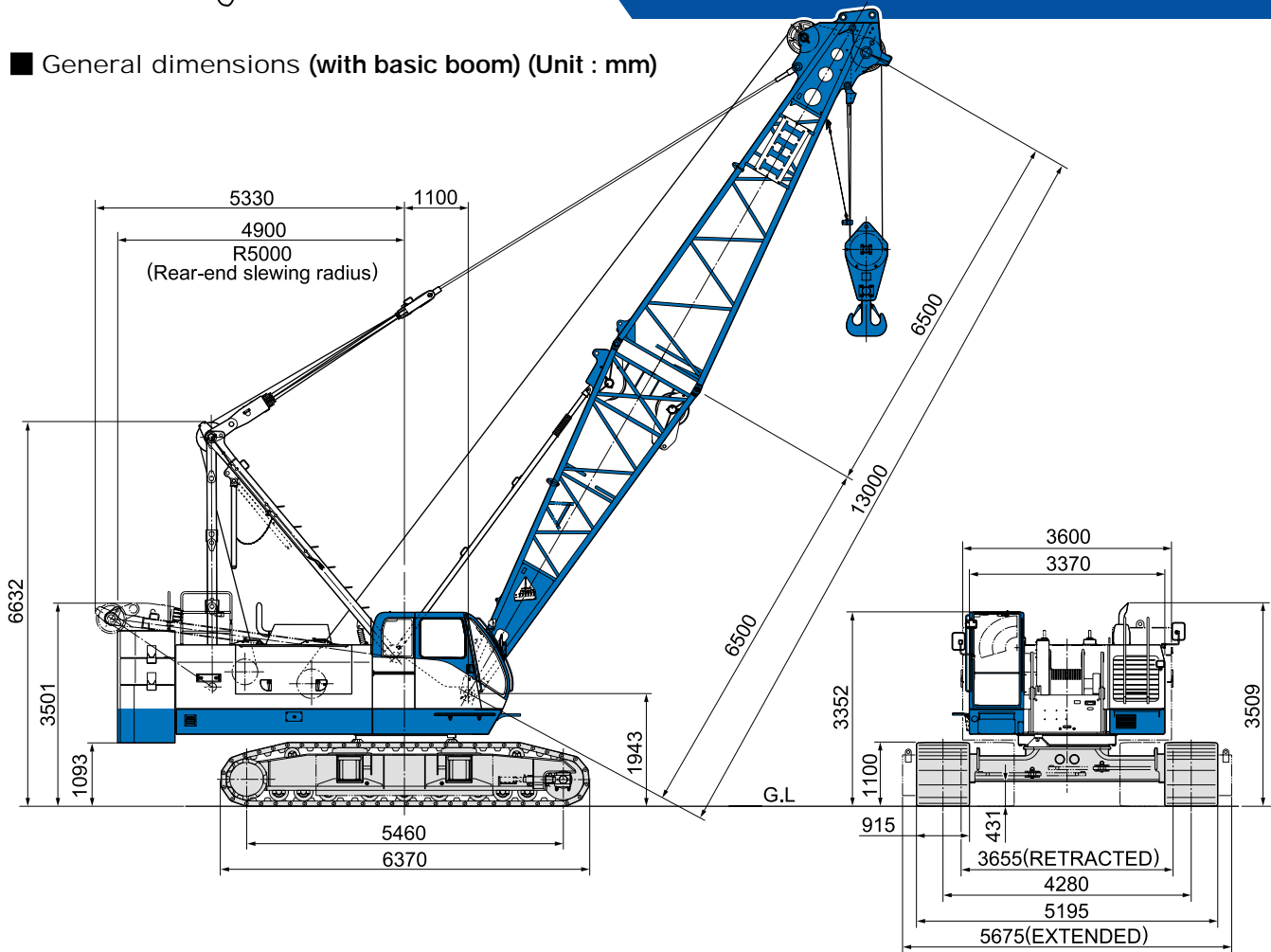

## Main specifications

Performance	
Slewing speed	3.0 rpm
Travel speed	1.4/1.0 km/hr
Gradeability	30% (16.7°)
Engine	
Make	Cummins Inc.
Model	OSB6.7
Type	4-cycle, water-cooled, turbocharged and air cooled
Total displacement	6.7 L
Rated output	179 kW / 2,000 min <sup>-1</sup> (240 HP / 2,000 rpm)
Fuel tank capacity	400 L
Battery	12 V × 120 AH × 2 pcs.
Load hoist system (Main & Aux.)	
Hydraulic motor	Axial piston type
Reduction gear	Main drum : Two-stage planetary gear Aux drum : One-stage planetary gear and single stage spur gear
Hoist drum	2-grooved cylindrical drums on 2 individual shafts, with lebus type groove
Clutch	Internal expanding band type
Brake	External contracting band type
Drum lock	Ratchet type
Boom hoist system	
Hydraulic motor	Axial piston type
Reduction gear	Two-stage planetary gear
Hoist drum	Grooved cylindrical single drum on shaft, with lebus type groove
Brake	Wet type multi disc
Drum lock	Ratchet type

## Crane specifications

Max. lifting capacity (metric ton) × working radius (m)	90 × 4.0	
Max. main boom length (m)	61	
Max. boom length with jib (main + jib) (m)	68 (46 + 22)	
Rope speed	Main hoisting/lowering (m/min)	*High 100 / 75 ; Lo 50-38
	Auxiliary hoisting/lowering (m/min)	*High 100 / 82 ; Lo 50-41
	Boom hoisting/lowering (m/min)	*55
Part lines	90 ton hook block	9 part lines
	15 ton hook block	2 part lines
	Boom hoisting/lowering	12 part lines
Standard counterweight (ton)	24.0	
Crawler weight (ton)	10.5	
Total operating weight (with 13m basic boom) (ton)	Approx. 84.2	
Average ground bearing pressure (kPa) [kg/cm <sup>2</sup> ]	(82) [0.84]	

Note 1 : The value marked with "\*" may change depending on the loads given.

## Standard equipment

### 1. Base Machine

- Counterweight (24.0 ton)
- Crawler weight (10.5 ton)
- Counterweight removal system
- Engine tachometer (with hour meter)
- Engine diagnostics (with idle speed control)
- Hydraulic pressure gauge
- Fuel gauge
- Engine coolant temperature gauge
- Front work lamp (on both sides)
- Operator's room lamp
- Air conditioner
- Front windshield wiper
- Bronze tinted glass
- Ceiling wiper
- Sun shade
- Reclining operator's seat
- Sun-visor
- Cigarette lighter
- Rear view mirrors (on both sides)
- Radio
- Ashtray
- Storage pouch
- Electric fuel pump
- Swing flashing light
- Travel warning Buzzer
- Swing warning Buzzer
- Electrical engine throttle control grip
- Engine throttle pedal
- Ultra low speed control
- Winch mode selector (main and aux.)
- Automatic brake system
- Hydraulic assist brake (main and aux.)
- Rope guide roller on boom back (for outer boom)
- Foot rest
- Floor mat
- Steps for operator's cab
- Plug socket (24V)
- Standard tools for maintenance (details are as per Parts Catalogue)

## Options

### 1. Base Machine

- Tagline
- Drum rotation indicator
- Fire extinguisher
- Combustion type heater
- Electric fan
- Spark arrestor
- Operator gate lock lever
- Name plate (both sides of base machine)

### 2. Light and Instrument

- Yellow rotary light
- Boom point clearance lamp
- Over load outside alarm light (red/yellow/green)
- Work light on boom
- Work light for rear direction
- Level indicator
- Anemometer

### 3. Step and guard

- Wire mesh for boom walkway

### 4. Attachment

- 3 m, 6 m, 9 m insert boom (with pendant rope and rope guide roller)
- 10 m basic jib and accessories
- 3m, 6m insert jib (with pendant rope)
- 1m auxiliary jib and accessories
- 60 ton hook block (three sheaves)
- 50 ton hook block (three sheaves)
- 30 ton hook block (one sheave)
- 10 ton hook block
- 7 ton hook block
- 15 ton hook block (for assembly and disassembly)
- Auxiliary hoisting wire rope
- Name plate (both sides of outer boom)

### 5. Others

- Large size tool box (with caster)
- Sling wire rope (for lifting counter weight or crawler)

## Combination of main boom and jib boom

Boom length(m) Jib length(m)	13	16	19	22	25	28	31	34	37	40	43	46	49	52	55	58	61
Aux.	●	●	●	●	●	●	●	●	●	●	●	●	●	●	●	●	●
10								●	●	●	●	●	●				
13								●	●	●	●	●	●				
16								●	●	●	●	●	●				
19								●	●	●	●	●	●				
22								●	●	●	●	●	●				

●:Applicable combination

## Wire rope

Purpose	Rope dia. (mm)	Breaking Strength (kN)	Rope Type (Std.length)
Main hoisting	φ26	598	P•S(19)+39×P•7(230m)
Boom hoisting	φ19	302	IWRC 6×P•WS(31)(150m)
Boom suspension	φ34	1020	IWRC 6×P•WS(36)
Auxiliary hoisting	φ22.4	440	P•S(19)+39×P•7(150m)
Jib suspension	φ28	585	IWRC 6×Fi(29)
Jib strut suspension	φ28	585	IWRC 6×Fi(29)

Note:Designed and rated in compliance with ANSI Code B30.5-1.7.1

## Boom composition

Boom length (m)	13	16	19	22	25	28	31	34	37
6.5 m Inner	1	1	1	1	1	1	1	1	1
3 m Insert	—	1	2	1	2	2	1	2	2
6 m Insert	—	—	—	1	1	—	1	1	—
9 m Insert	—	—	—	—	—	1	1	1	2
6.5 m Outer	1	1	1	1	1	1	1	1	1

Boom length (m)	40	43	46	49	52	55	58	61
6.5 m Inner	1	1	1	1	1	1	1	1
3 m Insert	1	2	2	1	2	1	1	2
6 m Insert	1	1	—	1	1	2	1	1
9 m Insert	2	2	3	3	3	3	4	4
6.5 m Outer	1	1	1	1	1	1	1	1

## Jib boom composition

Jib length (m)	10	13	16	19	22
4.5 m Inner	1	1	1	1	1
3 m Insert	—	1	2	1	2
6 m Insert	—	—	—	1	1
5.5m Outer	1	1	1	1	1

## Working range (No loaded condition)

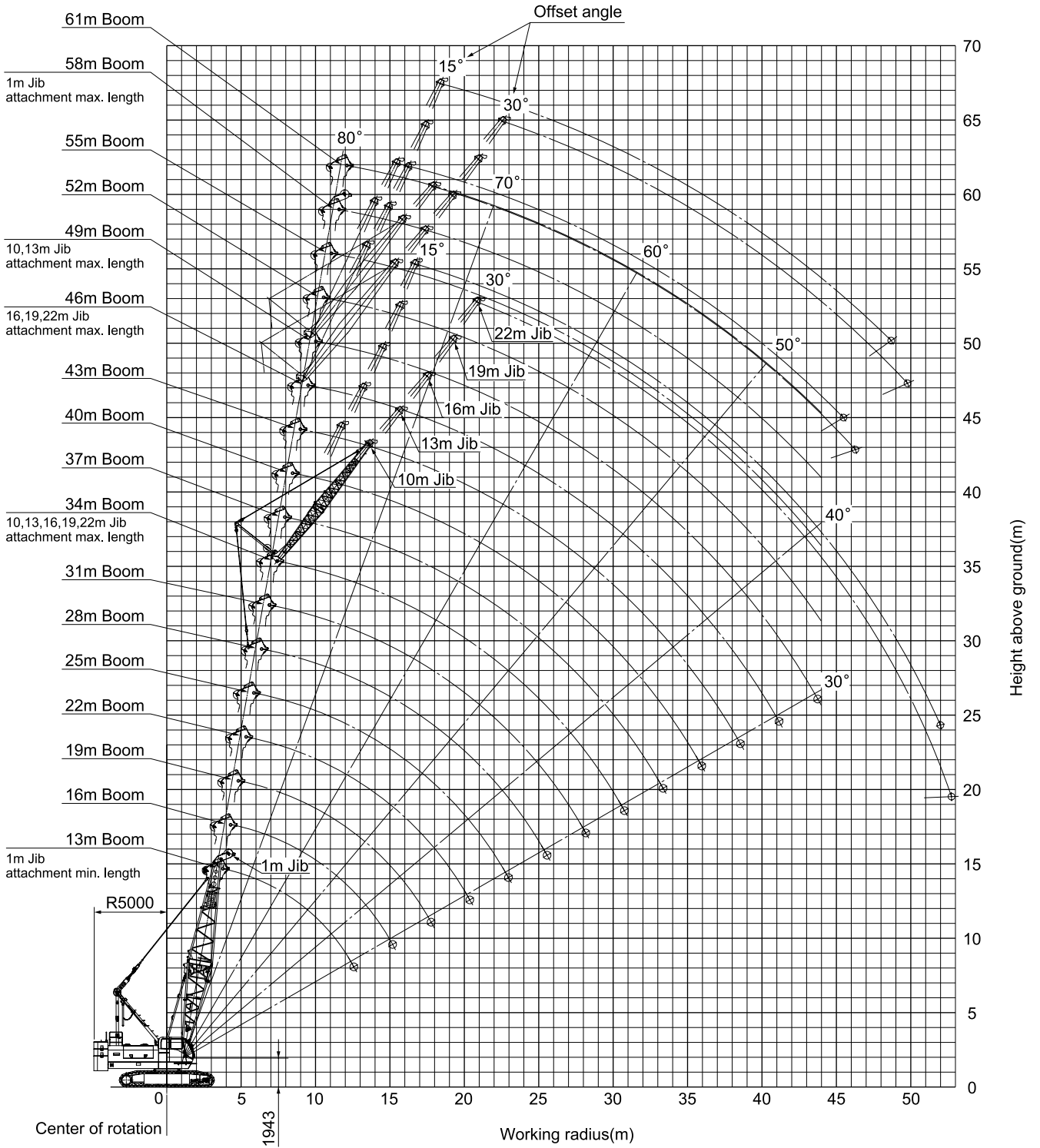
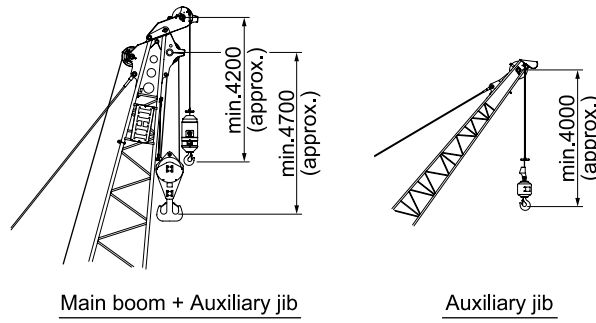

■ Main boom rated lifting loads (with 24 ton counterweight, 10.5 ton crawlerweight and 26mm wire rope)

Unit: metric ton

Boom length(m) Working radius(m)	13.0	16.0	19.0	22.0	25.0	28.0	31.0	34.0	37.0	40.0	43.0	46.0	49.0	52.0	55.0	58.0	61.0
4.0	90.0																
4.5	87.4	86.0															
5.0	77.2	77.0	74.3														
6.0	57.7	57.6	57.4	57.3	57.2												
7.0	45.1	45.0	45.0	44.9	44.8	44.7	7.5m× 40.2										
8.0	37.1	36.9	36.8	36.8	36.7	36.6	36.5	36.4	8.5m× 33.2								
9.0	31.5	31.4	31.3	31.1	30.9	30.9	30.8	30.6	30.5	30.4	9.5m× 28.0						
10.0	27.4	27.2	27.0	26.8	26.7	26.6	26.5	26.3	26.3	26.2	26.0	25.9	10.5m× 24.1				
12.0	21.5	21.4	21.2	20.9	20.8	20.7	20.6	20.4	20.3	20.2	20.1	20.0	19.9	19.7	19.6	14.3	12.5m× 12.0
14.0	12.6m× 20.1	17.8	17.6	17.0	16.9	16.8	16.7	16.5	16.4	16.3	16.2	16.1	16.0	15.8	15.7	12.4	10.6
16.0		15.2m× 15.6	14.6	14.3	14.1	14.0	13.9	13.7	13.7	13.5	13.4	13.3	13.2	13.0	12.9	10.8	9.2
18.0			17.8m× 12.5	12.2	12.0	11.9	11.8	11.7	11.6	11.5	11.3	11.2	11.1	10.9	10.8	9.5	8.0
20.0				10.6	10.4	10.3	10.2	10.1	10.0	9.9	9.7	9.6	9.5	9.3	9.2	8.4	7.0
22.0				20.4m× 10.3	9.1	9.1	9.0	8.8	8.7	8.6	8.4	8.3	8.2	8.1	7.9	7.4	6.1
24.0					23.0m× 8.6	8.0	7.9	7.7	7.6	7.5	7.4	7.3	7.2	7.0	6.9	6.6	5.3
26.0						25.6m× 7.3	7.0	6.9	6.8	6.7	6.5	6.4	6.3	6.1	6.0	5.8	4.7
28.0							28.2m× 6.2	6.1	6.0	5.9	5.8	5.7	5.6	5.4	5.3	5.2	4.1
30.0								5.5	5.4	5.3	5.1	5.0	4.9	4.8	4.7	4.6	3.5
32.0								30.8m× 5.3	4.9	4.8	4.6	4.5	4.4	4.2	4.1	4.0	3.0
34.0									33.4m× 4.5	4.3	4.1	4.0	3.9	3.7	3.6	3.5	2.6
36.0										3.9	3.7	3.6	3.5	3.3	3.1	3.0	2.2
38.0										36.1m× 3.8	3.3	3.2	3.0	2.8	2.7	2.5	1.8
40.0											38.6m× 3.2	2.8	2.7	2.4	2.3	2.2	1.4
42.0												41.1m× 2.6	2.3	2.1	1.9	1.8	1.1
44.0													43.7m× 2.0	1.8	1.6	1.5	0.7
No. of part line	9	9	8	6	6	5	5	4	4	4	3	3	3	2	2	2	2

Note1 : Rated loads shown in bold lines are based on structural strength factors.

■ Aux jib rated lifting loads (with 24 ton counterweight, 10.5 ton crawlerweight and 22.4mm wire rope)

Unit: metric ton

Boom length(m) Working radius(m)	13.0	16.0	19.0	22.0	25.0	28.0	31.0	34.0	37.0	40.0	43.0	46.0	49.0	52.0	55.0	58.0
4.0	4.4m× 7.0	4.9m× 7.0														
5.0	7.0	7.0	5.4m× 7.0													
6.0	7.0	7.0	7.0	7.0	6.5m× 7.0											
7.0	7.0	7.0	7.0	7.0	7.0	7.0	7.5m× 7.0									
8.0	7.0	7.0	7.0	7.0	7.0	7.0	7.0	7.0	8.6m× 7.0							
9.0	7.0	7.0	7.0	7.0	7.0	7.0	7.0	7.0	7.0	9.1m× 7.0	9.6m× 7.0					
10.0	7.0	7.0	7.0	7.0	7.0	7.0	7.0	7.0	7.0	7.0	7.0	10.1m× 7.0	10.6m× 7.0	11.2m× 7.0	11.7m× 7.0	
12.0	7.0	7.0	7.0	7.0	7.0	7.0	7.0	7.0	7.0	7.0	7.0	7.0	7.0	7.0	7.0	12.2m× 7.0
14.0	13.8m× 7.0	7.0	7.0	7.0	7.0	7.0	7.0	7.0	7.0	7.0	7.0	7.0	7.0	7.0	7.0	7.0
16.0		16.4m× 7.0	7.0	7.0	7.0	7.0	7.0	7.0	7.0	7.0	7.0	7.0	7.0	7.0	7.0	7.0
18.0			19.0m× 7.0	7.0	7.0	7.0	7.0	7.0	7.0	7.0	7.0	7.0	7.0	7.0	7.0	7.0
20.0				7.0	7.0	7.0	7.0	7.0	7.0	7.0	7.0	7.0	7.0	7.0	7.0	7.0
22.0				21.6m× 7.0	7.0	7.0	7.0	7.0	7.0	7.0	7.0	7.0	7.0	7.0	7.0	6.9
24.0					7.0	7.0	7.0	7.0	7.0	7.0	6.9	6.8	6.7	6.5	6.4	6.1
26.0					24.2m× 7.0	6.6	6.5	6.4	6.3	6.2	6.0	5.9	5.8	5.6	5.5	5.3
28.0						26.8m× 6.3	5.8	5.6	5.5	5.4	5.3	5.2	5.1	4.9	4.8	4.7
30.0							29.4m× 5.4	5.0	4.9	4.8	4.6	4.5	4.4	4.3	4.2	4.2
32.0								4.5	4.4	4.3	4.2	4.0	3.9	3.7	3.6	3.5
34.0									34.6m× 3.8	3.8	3.6	3.5	3.4	3.2	3.1	3.0
36.0										3.4	3.2	3.1	3.0	2.8	2.6	2.5
38.0										37.2m× 3.1	2.8	2.7	2.5	2.3	2.2	2.0
40.0											39.8m× 2.5	2.3	2.2	1.9	1.8	1.7
42.0												42.4m× 1.9	1.8	1.6	1.4	1.3
44.0													1.5	1.3	1.1	1.0

## Jib rated lifting loads (with 24 ton counterweight, 10.5 ton crawlerweight and 22.4mm wire rope)

Unit: metric ton

Boom length (m)	34.0										37.0									
	10.0		13.0		16.0		19.0		22.0		10.0		13.0		16.0		19.0		22.0	
Jib length (m)	15°	30°	15°	30°	15°	30°	15°	30°	15°	30°	15°	30°	15°	30°	15°	30°	15°	30°	15°	30°
Offset angle																				
Working radius (m)																				
10.0	11.6m × 7.0																			
12.0	7.0	13.4m × 5.0	13.0m × 7.0								12.1m × 7.0		13.6m × 7.0							
14.0	7.0	5.0	7.0	15.5m × 5.0	14.4m × 7.0		15.5m × 5.0				7.0	5.0	7.0		14.9m × 7.0					
16.0	7.0	5.0	7.0	5.0	7.0	17.3m × 5.0	5.0		16.5m × 5.0		7.0	5.0	7.0	5.0	7.0	17.9m × 5.0	5.0		17.0m × 5.0	
18.0	7.0	5.0	7.0	5.0	7.0	5.0	5.0	19.1m × 3.5	5.0		7.0	5.0	7.0	5.0	7.0	5.0	5.0	19.6m × 3.5	5.0	
20.0	7.0	5.0	7.0	5.0	7.0	5.0	5.0	3.5	5.0	20.7m × 3.5	7.0	5.0	7.0	5.0	7.0	5.0	5.0	3.5	5.0	21.2m × 3.5
22.0	7.0	5.0	7.0	5.0	7.0	5.0	5.0	3.5	5.0	3.5	7.0	5.0	7.0	5.0	7.0	5.0	5.0	3.5	5.0	3.5
24.0	7.0	5.0	7.0	5.0	7.0	5.0	5.0	3.5	5.0	3.5	7.0	5.0	7.0	5.0	7.0	5.0	5.0	3.5	5.0	3.5
26.0	6.6	5.0	6.7	5.0	6.9	5.0	5.0	3.5	5.0	3.5	6.5	5.0	6.6	5.0	6.8	5.0	5.0	3.5	5.0	3.5
28.0	5.8	5.0	6.0	5.0	6.1	5.0	5.0	3.5	5.0	3.5	5.7	5.0	5.8	5.0	6.0	5.0	5.0	3.5	5.0	3.5
30.0	5.2	5.0	5.3	5.0	5.5	5.0	5.0	3.5	5.0	3.5	5.1	5.0	5.2	5.0	5.3	5.0	5.0	3.5	5.0	3.5
32.0	4.6	4.7	4.8	4.9	4.9	5.0	5.0	3.5	5.0	3.5	4.5	4.6	4.6	4.8	4.7	5.0	4.9	3.5	5.0	3.5
34.0	4.1	4.2	4.3	4.4	4.4	4.5	4.5	3.5	4.6	3.5	4.0	4.1	4.1	4.3	4.2	4.5	4.4	3.5	4.5	3.5
36.0	3.7	3.7	3.8	3.9	4.0	4.1	4.0	3.5	4.1	3.5	3.6	3.7	3.7	3.8	3.8	4.0	3.9	3.5	4.0	3.5
38.0	3.3	3.3	3.4	3.4	3.6	3.7	3.6	3.5	3.7	3.5	3.2	3.3	3.3	3.4	3.4	3.6	3.5	3.5	3.6	3.5
40.0	3.0	3.0	3.0	3.0	3.2	3.3	3.3	3.4	3.4	3.5	2.8	2.9	2.9	3.0	3.0	3.2	3.1	3.3	3.2	3.5
42.0			2.7	2.7	2.9	2.9	3.0	3.1	3.1	3.2	2.5	2.5	2.6	2.6	2.7	2.8	2.8	3.0	2.9	3.1
44.0			43.0m × 2.6	43.0m × 2.6	2.6	2.6	2.7	2.7	2.8	2.9	43.0m × 2.3	43.0m × 2.3	2.3	2.3	2.4	2.5	2.5	2.7	2.6	2.7
46.0					2.3	2.3	2.4	2.4	2.5	2.6			2.0	2.0	2.1	2.2	2.2	2.4	2.3	2.4
48.0							2.1	2.1	2.2	2.3					1.8	1.9	1.9	2.1	2.0	2.1
50.0							49.0m × 2.0	49.0m × 2.0	1.9	2.0					49.0m × 1.7	49.0m × 1.8	1.7	1.8	1.8	1.8
52.0									1.7	1.8							51.0m × 1.6	51.0m × 1.7	1.6	1.6
54.0																				53.0m × 1.5

Boom length (m)	40.0										43.0									
	10.0		13.0		16.0		19.0		22.0		10.0		13.0		16.0		19.0		22.0	
Jib length (m)	15°	30°	15°	30°	15°	30°	15°	30°	15°	30°	15°	30°	15°	30°	15°	30°	15°	30°	15°	30°
Offset angle																				
Working radius (m)																				
10.0																				
12.0	12.6m × 7.0										13.1m × 7.0									
14.0	7.0	14.5m × 5.0	14.1m × 7.0		15.4m × 7.0						7.0	15.0m × 5.0	14.6m × 7.0		15.9m × 7.0					
16.0	7.0	5.0	7.0	16.5m × 5.0	7.0		16.6m × 5.0		17.6m × 5.0		7.0	5.0	7.0	17.0m × 5.0	7.0		17.1m × 5.0			
18.0	7.0	5.0	7.0	5.0	7.0	18.4m × 5.0	5.0		5.0		7.0	5.0	7.0	5.0	7.0	18.9m × 5.0	5.0		18.1m × 5.0	
20.0	7.0	5.0	7.0	5.0	7.0	5.0	5.0	20.1m × 3.5	5.0	21.7m × 3.5	7.0	5.0	7.0	5.0	7.0	5.0	5.0	20.6m × 3.5	5.0	
22.0	7.0	5.0	7.0	5.0	7.0	5.0	5.0	3.5	5.0	3.5	7.0	5.0	7.0	5.0	7.0	5.0	5.0	3.5	5.0	22.2m × 3.5
24.0	7.0	5.0	7.0	5.0	7.0	5.0	5.0	3.5	5.0	3.5	7.0	5.0	7.0	5.0	7.0	5.0	5.0	3.5	5.0	3.5
26.0	6.3	5.0	6.5	5.0	6.7	5.0	5.0	3.5	5.0	3.5	6.2	5.0	6.4	5.0	6.5	5.0	5.0	3.5	5.0	3.5
28.0	5.6	5.0	5.8	5.0	5.9	5.0	5.0	3.5	5.0	3.5	5.4	5.0	5.6	5.0	5.8	5.0	5.0	3.5	5.0	3.5
30.0	5.0	5.0	5.1	5.0	5.2	5.0	5.0	3.5	5.0	3.5	4.8	5.0	5.0	5.0	5.1	5.0	5.0	3.5	5.0	3.5
32.0	4.4	4.5	4.5	4.7	4.7	4.9	4.8	3.5	4.8	3.5	4.2	4.4	4.4	4.6	4.5	4.8	4.6	3.5	4.7	3.5
34.0	3.9	4.0	4.0	4.2	4.2	4.4	4.3	3.5	4.3	3.5	3.7	3.9	3.9	4.1	4.0	4.2	4.1	3.5	4.2	3.5
36.0	3.5	3.6	3.6	3.7	3.7	3.9	3.8	3.5	3.9	3.5	3.3	3.4	3.5	3.6	3.6	3.8	3.7	3.5	3.7	3.5
38.0	3.1	3.2	3.2	3.2	3.3	3.5	3.4	3.5	3.5	3.5	2.9	3.0	3.1	3.2	3.2	3.4	3.3	3.5	3.3	3.5
40.0	2.7	2.8	2.8	2.8	2.9	3.1	3.0	3.3	3.1	3.4	2.5	2.6	2.7	2.8	2.8	3.0	2.9	3.1	2.9	3.2
42.0	2.3	2.4	2.5	2.5	2.6	2.7	2.7	2.9	2.8	3.0	2.2	2.2	2.3	2.4	2.4	2.6	2.5	2.7	2.6	2.8
44.0	2.0	2.1	2.2	2.2	2.3	2.4	2.4	2.6	2.5	2.6	1.8	1.9	2.0	2.0	2.1	2.2	2.2	2.4	2.3	2.5
46.0	45.0m × 1.9	1.8	1.9	1.9	2.0	2.1	2.1	2.3	2.2	2.3	1.5	1.6	1.7	1.7	1.8	1.9	1.9	2.1	2.0	2.2
48.0			1.6	1.6	1.7	1.8	1.8	2.0	1.9	2.0			47.0m × 1.6	47.0m × 1.6	1.5	1.6	1.6	1.8	1.7	1.9
50.0				49.0m × 1.5	49.0m × 1.6	1.5	1.6	1.7	1.7	1.8					49.0m × 1.5	49.0m × 1.5	1.5	49.0m × 1.6	49.0m × 1.6	1.6
52.0								51.0m × 1.6	51.0m × 1.6	1.6										51.0m × 1.5

■ Jib rated lifting loads (with 24 ton counterweight, 10.5 ton crawlerweight and 22.4mm wire rope)

Unit: metric ton

Boom length (m)	46.0										49.0				
Jib length (m)	10.0		13.0		16.0		19.0		22.0		10.0		13.0		
Offset angle	15°	30°	15°	30°	15°	30°	15°	30°	15°	30°	15°	30°	15°	30°	
Working radius (m)															
10.0															
12.0	13.6m × 7.0														
14.0	7.0	15.5m × 5.0	15.1m × 7.0									14.2m × 7.0		15.6m × 7.0	
16.0	7.0	5.0	7.0	17.5m × 5.0	15.4m × 7.0			17.6m × 5.0				7.0	18.1m × 5.0	7.0	
18.0	7.0	5.0	7.0	5.0	7.0	19.4m × 5.0	5.0			18.6m × 5.0		7.0	5.0	7.0	18.1m × 5.0
20.0	7.0	5.0	7.0	5.0	7.0	5.0	5.0	21.2m × 3.5	5.0	5.0		7.0	5.0	7.0	5.0
22.0	7.0	5.0	7.0	5.0	7.0	5.0	5.0	3.5	5.0	22.8m × 3.5		7.0	5.0	7.0	5.0
24.0	7.0	5.0	7.0	5.0	7.0	5.0	5.0	3.5	5.0	3.5		6.9	5.0	7.0	5.0
26.0	6.1	5.0	6.3	5.0	6.4	5.0	5.0	3.5	5.0	3.5		6.0	5.0	6.2	5.0
28.0	5.3	5.0	5.5	5.0	5.7	5.0	5.0	3.5	5.0	3.5		5.2	5.0	5.4	5.0
30.0	4.7	4.9	4.9	5.0	5.0	5.0	5.0	3.5	5.0	3.5		4.6	4.8	4.8	5.0
32.0	4.1	4.3	4.3	4.5	4.4	4.7	4.5	3.5	4.6	3.5		4.0	4.2	4.2	4.4
34.0	3.7	3.8	3.8	4.0	3.9	4.2	4.0	3.5	4.1	3.5		3.5	3.7	3.7	3.9
36.0	3.2	3.3	3.3	3.5	3.5	3.7	3.6	3.5	3.7	3.5		3.0	3.2	3.2	3.4
38.0	2.8	2.9	2.9	3.1	3.1	3.2	3.2	3.4	3.3	3.5		2.6	2.7	2.8	3.0
40.0	2.4	2.5	2.5	2.7	2.7	2.8	2.8	3.0	2.9	3.2		2.2	2.3	2.4	2.6
42.0	2.0	2.1	2.2	2.3	2.3	2.4	2.4	2.6	2.5	2.8		1.9	1.9	2.0	2.2
44.0	1.7	1.8	1.9	2.0	2.0	2.1	2.1	2.2	2.2	2.4		1.6	1.6	1.7	1.9
46.0	45.0m × 1.6	1.5	1.6	1.7	1.7	1.8	1.8	1.9	1.9	2.0			45.0m × 1.5	45.0m × 1.6	1.6
48.0				47.0m × 1.5	47.0m × 1.6	1.5	1.5	1.7	1.6	1.7					
50.0								49.0m × 1.6		1.5					

## ■ Notes

1. All rated loads are based on the machine being operated on the firm, level, uniformly supporting surface ground, at any point of 360° around the machine within 78% of tipping load and forward stability factor over 1.15.

Working radius is horizontal distance from center of rotation to a vertical line through the center of gravity of the load.

2. To determine actual lifting loads, the weight of all lifting devices such as hook must be reduced from the lifting loads.

90 ton hook	1,500 kg	15 ton hook	300 kg
60 ton hook	1,250 kg	(for assembly and disassembly)	
50 ton hook	700 kg	10 ton hook	400 kg
30 ton hook	600 kg	7 ton hook	250 kg

3. The following weight must be reduced from the lifting loads to determine rated lifting loads for main boom when the jib is equipped.

Aux. jib	800 kg	16.0 m jib	3,200 kg
10.0 m jib	2,300 kg	19.0 m jib	3,600 kg
13.0 m jib	2,700 kg	22.0 m jib	4,100 kg

4. Depending on the number of part lines, rated lifting loads are limited as follows.

1 part line	up to 10.0 ton	6 part lines	up to 60.0 ton
2 part lines	up to 20.0 ton	7 part lines	up to 70.0 ton
3 part lines	up to 30.0 ton	8 part lines	up to 80.0 ton
4 part lines	up to 40.0 ton	9 part lines	up to 90.0 ton
5 part lines	up to 50.0 ton		

5. The aux. jib can be equipped in the range of boom length from 13 m to 58 m boom. To determine the rated lifting loads, 0.8 ton must be reduced from the lifting loads for each boom length in the lifting load chart. However the max. lifting load should not exceed aux. jib capacity of the load.

6. When the 10 m~22 m jib mounted, the lifting loads to be determined by "Jib Rated Lifting Loads".

7. The total weight of the main hook and the jib hook must be reduced from the rated load when lifting on the jib hook with the main hook being attached.

8. The angle formed by the extension line of main boom and the centerline of jib (offset angle) should not exceed 30 degree while the loads being lifted.

## IHI IHI Construction Machinery Limited

Kishi-Tokai Bldg., 8-4-4 Nishikamata, Ota-ku, Tokyo 144-8577 JAPAN  
Phone: +81-3-5714-8844 Fax: +81-3-5714-8840, 8841

Specifications are subject to change without notice due to technical improvements or modifications.  
Distributed by

