

PK 17502

Performance

PALFINGER



THE MOST MANOEUVRABLE IN ITS CLASS



PK 17502 – A CRANE WHICH INCORPORATES DECADES OF EXPERIENCE

The PK 17502 *Performance* has a knuckle boom working angle of 195° – the POWER LINK PLUS – and as a result can handle a wider range of duties than has been possible up to now for models in its class. Elements such as the double linkage system, the internally routed oil ducts and return oil utilisation endow this crane with unrivalled compactness and movement geometry.

Fitted with a winch, hose equipment for attachments or a fly-jib, the PK 17502 *Performance* becomes a universal and cost-efficient working unit.



FUNCTIONAL DESIGN AND PERFECT APPLICATIONS ENGINEERING

Adjustable slide blocks

These ensure optimal lateral guidance of the extension system.

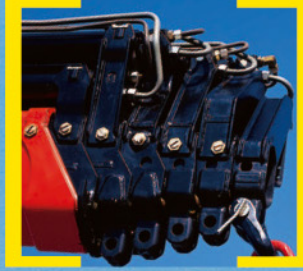

Functional design

- Enclosure of the entire electronic system
- Enclosure in the area of the control valve
- Enclosure of the hoses behind the crane column
- Spiral tube hose between base frame and crane column



Ergonomic crane control

The operating levers for all crane functions are ergonomically arranged on the console, which makes for comfortable and efficient working. In addition, the control console is mounted for easy servicing.



Return oil utilisation

The high speed of the extension system is impressive. It results from return oil utilisation, which is installed as standard, and the generously dimensioned hydraulic lines. This makes for increased efficiency in any type of working.



Load-holding valves

They prevent the crane arm from dropping and are mounted as standard on the elevating and knuckle-boom cylinder as well as on the extension arm. The valves are positioned in such a way that they are protected from being damaged.

POWER LINK PLUS

PALFINGER has specially developed this knuckle boom so that it can be angled upwards by 15 degrees. It stands out by virtue of the excellent movement geometry. Even in the most restricted spaces, difficult crane jobs can be carried out with ease.



MANOEUVRABILITY THAT PAYS OFF



Extension system

The extension cylinders are guided in Jordal rails over rollers.

Height compensation of the extension cylinders.



Hose equipment for accessories

With this option you can provide the oil supply to accessories. The hoses are routed in compact troughs and plastic link chains. They are therefore very well protected.

Internally routed oil ducts

The internally routed oil ducts permit a compact design for the extension system and ensure perfect protection from damage.

Outriggers

The standard 4.8 m outriggers ensure optimum stability. As an option a 6.6 m telescopic outrigger is available. The pipework to the support cylinders is internally routed in the outriggers, providing a high level of protection from damage at all times. On request, the outriggers can be supplied with support cylinders that swivel up hydraulically through 180°.

Optional

- The PALFINGER radio remote control
- The PALTRONIC 50 electronic control system
- The hydraulic overload protection

Central lubrication

For all bearings on the base frame.



WELL LOOKED AFTER BY MORE THAN 1500 PALFINGER CONTRACT PARTNERS WORLDWIDE

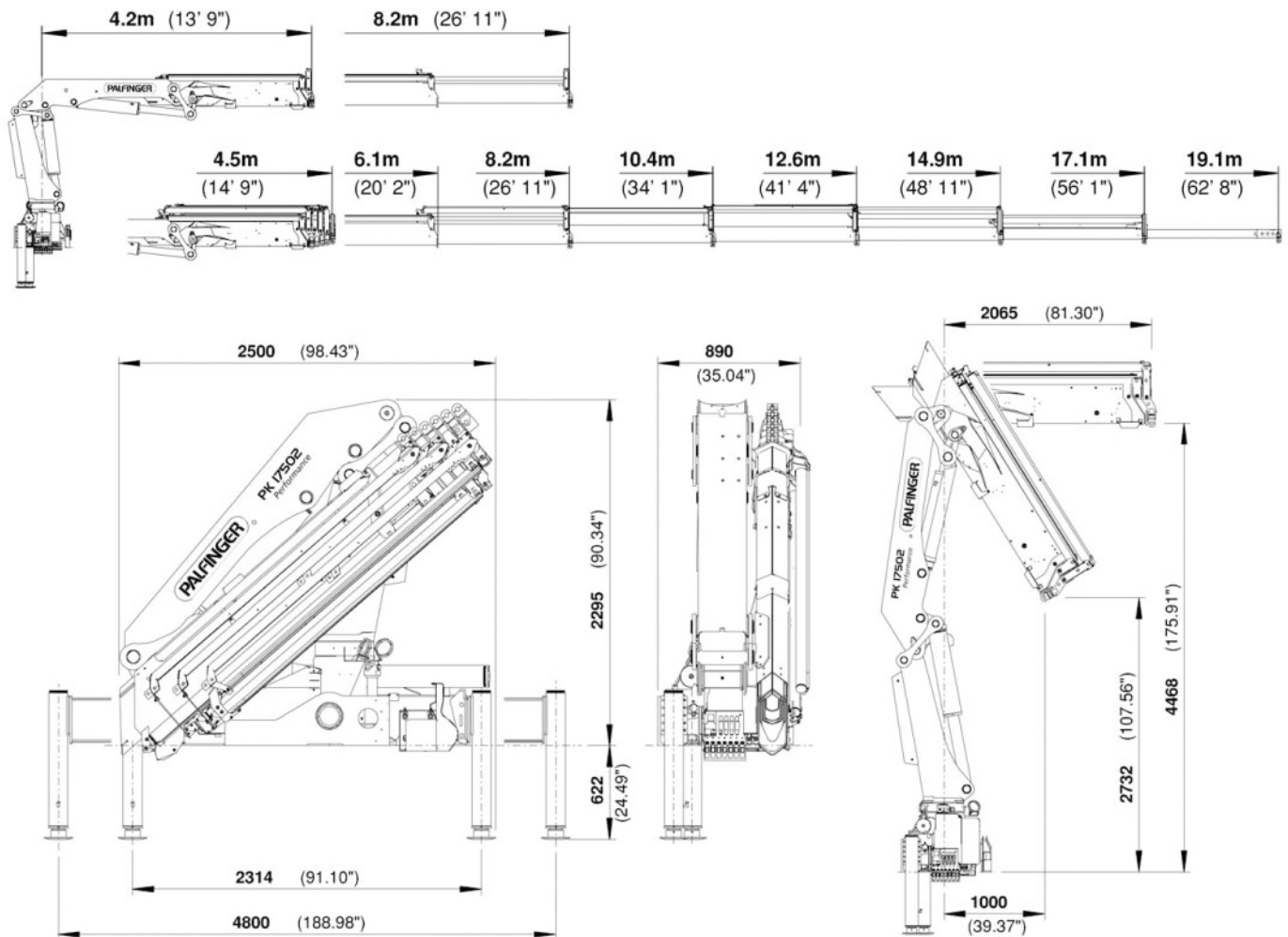

PK 17502 Performance			
Technical Specifications (DIN 15018 H1-B3)			
Max. lifting moment	17.0 mt/167.2 kNm	123280 ft.lbs	
Max. lifting capacity	6100 kg/59.8 kN	13450 lbs	
Max. hydraulic outreach	17.1 m	56' 1"	
Max. outreach (with fly-jib)	25.5 m	83' 8"	
Slewing angle	400°		

PK 17502 Performance			
Standard crane			
Slewing torque	2.3 mt/22.6 kNm	16660 ft.lbs	
Outreach	8.2 m	26' 11"	
Stabilizer spread standard	4.8 m	15' 9"	
Stabilizer spread max.	6.6 m	21' 8"	
Fitting space required	0.89 m	2' 11"	
Width folded	2.5 m	8' 2"	
Max. operating pressure	300 bar	4350 psi	
Recommended pump capacity	from 45 l/min	9.9 imp.gal./min	11.9 US gal./min
	to 65 l/min	14.3 imp.gal./min	17.2 US gal./min
with RC- control and LS-system	from 65 l/min	14.3 imp.gal./min	17.2 US gal./min
	to 80 l/min	17.6 imp.gal./min	21.1 US gal./min
Dead weight standard crane	2255 kg	4970 lbs	

Applications shown in the leaflet do not always correspond to the standard specifications. Country-specific regulations must be considered for the crane installation.



TAILOR-MADE TO WORK FOR YOU

Max. lifting capacities

PK 17502 Performance A			
Max. lifting capacities 6100 kg 13450 lbs			
Outreach		Capacity	
hydraulic			
4.1 m	13' 5"	4100 kg	9040 lbs
6.1 m	20' 0"	2690 kg	5930 lbs
8.1 m	26' 7"	2010 kg	4430 lbs

PK 17502 Performance B			
Max. lifting capacities 5950 kg 13120 lbs			
Outreach		Capacity	
hydraulic			
4.1 m	13' 5"	3900 kg	8600 lbs
6.1 m	20' 0"	2520 kg	5560 lbs
8.1 m	26' 7"	1850 kg	4080 lbs
10.3 m	33' 10"	1440 kg	3170 lbs
manual			
12.5 m	41' 0"	1110 kg	2450 lbs
14.7 m	48' 3"	890 kg	1960 lbs
16.8 m	55' 1"	730 kg	1610 lbs

PK 17502 Performance C			
Max. lifting capacities 5800 kg 12790 lbs			
Outreach		Capacity	
hydraulic			
4.1 m	13' 5"	3730 kg	8220 lbs
6.1 m	20' 0"	2380 kg	5250 lbs
8.1 m	26' 7"	1710 kg	3770 lbs
10.3 m	33' 10"	1310 kg	2890 lbs
12.5 m	41' 0"	1070 kg	2360 lbs
manual			
14.7 m	48' 3"	860 kg	1900 lbs
16.8 m	55' 1"	700 kg	1540 lbs
18.8 m	61' 8"	600 kg	1320 lbs

PK 17502 Performance D			
Max. lifting capacities 5700 kg 12570 lbs			
Outreach		Capacity	
hydraulic			
4.1 m	13' 5"	3560 kg	7850 lbs
6.1 m	20' 0"	2240 kg	4940 lbs
8.1 m	26' 7"	1570 kg	3460 lbs
10.3 m	33' 10"	1180 kg	2600 lbs
12.5 m	41' 0"	950 kg	2090 lbs
14.7 m	48' 3"	800 kg	1760 lbs
manual			
16.9 m	55' 5"	650 kg	1430 lbs
18.9 m	62' 0"	550 kg	1210 lbs

PK 17502 Performance E			
Max. lifting capacities 5600 kg 12350 lbs			
Outreach		Capacity	
hydraulic			
4.1 m	13' 5"	3420 kg	7540 lbs
6.1 m	20' 0"	2120 kg	4670 lbs
8.1 m	26' 7"	1460 kg	3220 lbs
10.3 m	33' 10"	1060 kg	2340 lbs
12.5 m	41' 0"	830 kg	1830 lbs
14.7 m	48' 3"	670 kg	1480 lbs
16.9 m	55' 5"	580 kg	1280 lbs
manual			
18.9 m	62' 0"	490 kg	1080 lbs

PK 17502 Performance

