

General Specifications

Link-Belt®

Hydraulic Crane

HTC-50 50-ton (45.35 metric ton)

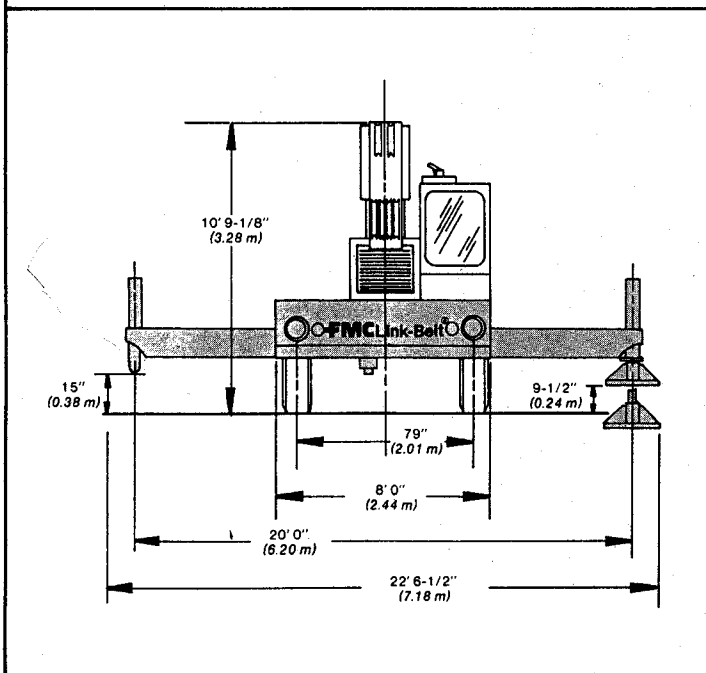
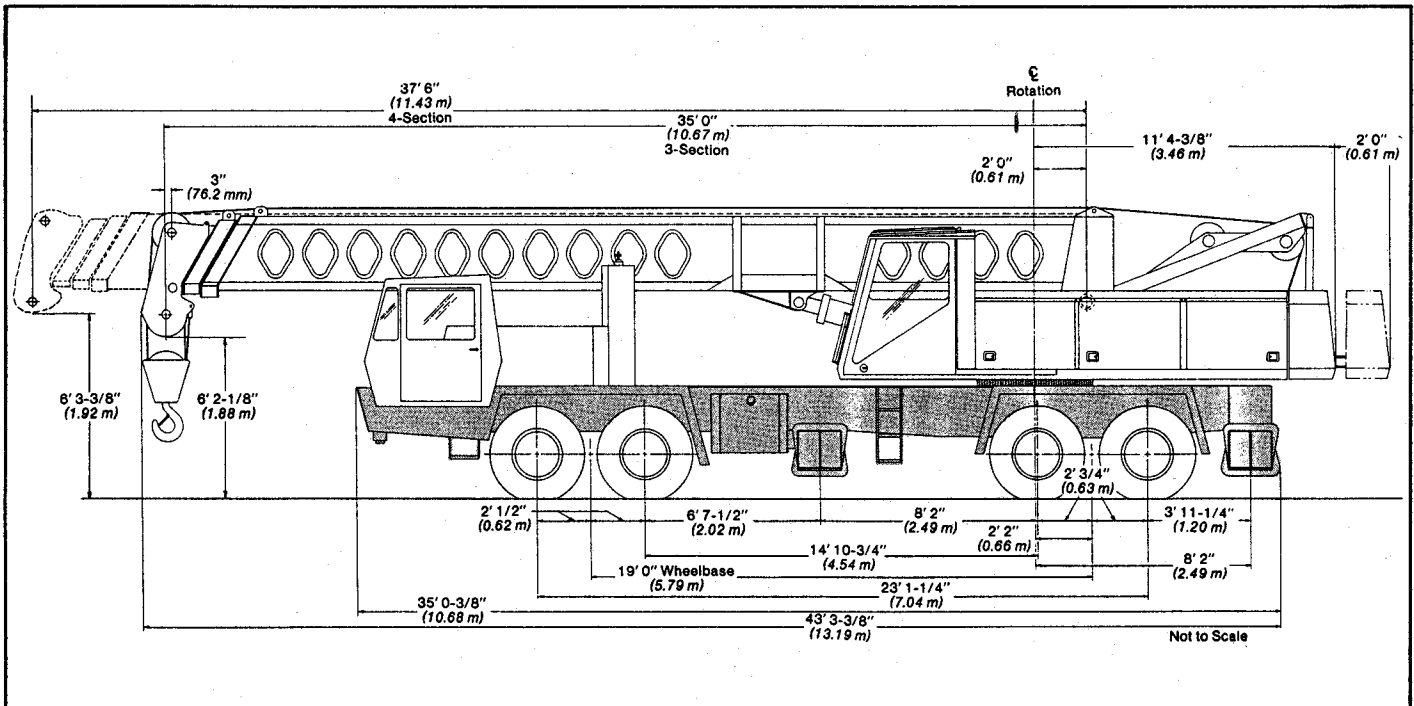

General dimensions	Feet	Meters
Turning radius - C/L of outer front tire	43' 0"	13.11
Tailswing - across corners	12' 1/8"	3.66
Tailswing - counterweight extended	13' 11"	4.24
Minimum ground clearance	9-1/2"	0.24

GENERAL INFORMATION ONLY

Upperstructure



Boom

FMC patented design. Boom side plates have diamond shaped impressions for superior strength to weight ratio and 100,000 p.s.i. (689.5 MPa) steel angle chords for lateral stiffness. Boom telescope sections are supported by wear shoes both vertically and horizontally.

Standard boom — 35' 0" - 90' 0" (10.67 m - 27.43 m) 3 - section power boom.

Boom head — Four or five 14-1/4" (0.36 m) root diameter head sheaves handle up to 10 parts of wire rope. Three removable wire rope guards, and rope dead end lugs provided on each side of boom head.

Auxiliary lifting sheave — Optional; single 14-1/4" (0.36 m) root diameter sheave mounted to boom head with removable wire rope guards. For use with one or two parts of line off the optional auxiliary winch. Does not affect erection of jib, or use of main head sheaves for multiple reeving.

Boom elevation — Two FMC designed double-acting 9-3/4" (0.25 m) diameter hydraulic cylinders with integral holding valves. Hand or foot controls for controlling boom elevation from - 5° to 75°.

Fly

Standard; 32' 0" (9.75 m) long, stowable two-piece lattice type consisting of a 5' (1.52 m) folding base section plus a 27' (8.23 m) lattice top section.

Jib

Optional; 28' 0" (8.53 m) straight lattice extension. Added to standard 32' 0" (9.75 m) two-piece lattice fly to make 60' (18.92 m) jib.

Jib Extension — Optional; 20' 0" (18.29 m) lattice added to 60' 0" (18.29 m) jib to make maximum 80' 0" (24.38 m) jib. Jib can be offset 7.5°.

Optional boom — 37' 6" - 120' 0" (11.98 m - 36.58 m) 4-section boom consisting of two power sections plus a manual. Requires bumper outrigger and 16.5 x 22.5 (16-PR) tires.

Auxiliary lifting sheave — Optional; single 14-1/4" (0.36 m) root diameter sheave mounted to boom head with removable wire rope guards. For use with one or two parts of line off the optional auxiliary winch. Does not affect erection of jib, or use of main head sheaves for multiple reeving.

Boom elevation — Two FMC designed double-acting 9-3/4" (0.25 m) diameter, hydraulic cylinders with integral holding valves. Hand or foot controls for controlling boom elevation from - 5° to 80°.

Fly

Standard; 34' 6" (10.52 m) stowable one-piece lattice type. (4-section only)

Jib

Optional; 30' 0" (9.14 m) stowable A-frame. Attaches to 34' 6" (10.52 m) fly only. Jib can be offset 5°, 17.5° or 30°.



Cab and Controls

Standard environmental cab; isolated from vibration by rubber mounts. Acoustical insulation and Neoprene weather seals. All safety glass windows with tinted roof glass. Removable front window and swing up roof window for maximum visibility and ventilation. Slide-by door opens to 3' 0" (0.91 m) width. 4-way adjustable operator's seat. Control levers for boom telescope, winches; dual controls for boom hoist and swing functions. Outrigger controls, sight leveling bubble, boom angle indicator, boom length and drum rotation indicators, windshield wiper, heater and defroster fan, instrumentation light and fire extinguisher.

Cab instrumentation — Standard illuminated gauges for engine oil pressure and water temperature, voltmeter, Speed-o-Matic® pressure, hydraulic oil temperature, fuel, and an engine on-and-off switch.



Swing

Bi-directional hydraulic swing motor mounted to FMC speed reducer for 360° continuous smooth swing at 2.7 r.p.m.

Swing brake — Two shoe, external contracting brake mounted to speed reducer. Foot or hand controlled.

Swing lock — Two position pin-type house lock operated from operator cab.

Counterweight — Extend/retract and removable. Standard machine with 3-section boom and one winch - 6,900 lbs. (3 130 kg). Standard machine with 3-section boom and optional auxiliary winch - 5,800 lbs. (2 631 kg). Standard machine with optional 4-section boom and one winch - 8,100 lbs. (3 674 kg). Standard machine with optional 4-section boom and auxiliary winch - 7,100 lbs. (3 221 kg).



Hydraulic System

Main pump — Tandem, triple gear-type pump. Powered by carrier engine with pump disconnect. Pump disconnect is a FMC jaw-type clutch engaged/disengaged from carrier cab. Maximum system pressure 2,800 p.s.i. (193.1 Bars).

Reservoir — FMC, 140 gallons (530.0 L) capacity. Internal baffles for tank strength, deaeration and oil cooling. Total system capacity 267 gallons (1 010.6 L)

Filter — 10 micron filter, located at return port of hydraulic reservoir. Replaceable cartridge.

Speed-o-Matic power hydraulic control system — Provides hydraulic power for 2-shoe clutch control of main and optional auxiliary winches. Maximum system pressure 1,050 p.s.i. (72.41 Bars).

GENERAL INFORMATION ONLY



Load hoist system

FMC's exclusive Dual Mode load hoisting/lowering system allows two modes of operation for variable speed and precise control.

For normal hydraulic operation, one mode allows the load to be hydraulically powered up/powered down in two speed ranges. This mode incorporates an automatic multiple disc brake to hold the load.

The second mode uses FMC's exclusive 2-shoe drum clutch for variable speed in hoisting and a drum brake for operator's controlled load lowering on the foot operated brake.

This exclusive design allows the operator to precisely feather the load while hoisting or lowering and allows the operator to achieve optimum speed, in addition to true gravity free fall, if desired.

Hoist motor — Two-speed hydraulic gear type; powers gear train through spur gear reduction.

Drum clutches — Two-shoe internal expanding. Engaged/disengaged from operators cab through Speed-o-Matic® power hydraulic system; 18" x 4-1/2" (0.46 m x 0.11 m). Clutch/brake drums cast integral with wire rope drum.

Drum brakes — Two-piece external contracting band; manually applied

and released by foot pedals in operator's cab. Brake drum diameter, 23" (0.58 m) brake band 4-1/2" (0.11 m) wide.

Line pulls and speeds — Maximum permissible line pull 16,800 lbs. (7 620 kg) and maximum permissible line speed 479 f.p.m. (146.00 m/min.)

Optional equipment — Load moment indication with kickout, anti-two block with audio/visual warning and kickout, auxiliary front drum, counterweight removal mechanism, boom and cab mounted working light packages, 50-ton (45.35 metric ton) hook block, 8-1/2-ton (7.71 metric ton) hook ball & swivel, and lifting lug package.

Chassis



Type

FMC 8 x 4 drive, 8' 0" (2.44 m) wide, 228" (5.79 m) wheelbase.

Frame — All-welded high strength alloy steel plate construction with box-type design and integral 100,000 p.s.i. (689.5 MPa) steel outrigger boxes.



Outriggers

Standard - Power hydraulic, double box, telescoping beam outriggers, front and rear. Vertical jack cylinders equipped with integral holding valve. Beams extend 20' 0" (6.10 m) centerline to centerline and retract to within 8' 0" (2.44 m) overall width. Equipped with stowable, lightweight 30-1/2" (0.77 m) diameter floats. Controls and sight level bubble located in upperstructure cab.

Bumper outrigger - Optional; a front center vertical jack mounted under bumper with 30-1/2" (0.77 m) diameter lightweight float. Standard with 4-section boom.

Axles

Front — Tandem; 79" (2.01 m) track.

Rear — Tandem; 72" (1.83 m) track, 6.833 to 1.0 ratio.

Suspension

Front — Reyco spring suspension with torque rods.

Rear — Hendrickson solid mount 50" (1.27 m) bogie beam.

Wheels

Front — Gunitite cast 5 spoke.

Rear — Gunitite cast 6 spoke.

Tires

Front — 12.0 x 20 (16-PR) transport type tubeless.

Rear — 11.0 x 20 (12-PR) transport type with tube.

Optional — 11.0 x 20 (12-ply) road lug type on rear only. 15.0 x 22.5 (16-PR) transport type on front only.



Brakes

Service — Dual wedge-type air brake system. Total effective lining area 1,632 sq. in. (10 530 cm²). Front - 15" x 6" (0.38 m x 0.15 m). Rear - 15" x 7" (0.38 m x 0.18 m).

Parking and emergency — One spring set, air released chamber per rear axle end. Parking brakes applied with air control valve mounted on carrier dash. Emergency brakes apply automatically when air pressure drops below 70 p.s.i. (48.27 Bars) in both systems.

Steering — Ross steering unit with hydraulic power assist.

Clutch — Lipe-Rollway 14" (0.36 m) diameter, spring loaded, double plate dry disc.

Universals — Mechanics needle; FMC midpoint bearing.

Transmission — Fuller Roadranger RTO-613, 13 speeds forward 3 reverse.



Electrical system

Standard; one 12-volt battery for GM and two 12 volt batteries for Cummins, 65 amp alternator. Two single sealed beam headlights, front and rear directional signals, stop and tail lights, 4-way emergency flashers, back-up lights, front, rear and side clearance lights with integral reflectors and license plate lights.



Carrier cab

Standard FMC one man low-profile, humanized cab. Acoustical insulation with vinyl covering, and mounted on rubber isolation pads. Equipped with electric windshield wiper, windshield washer, horn, mechanical spring suspended seat, dome and dash light, cigar lighter, ashtray, heater, defroster, door and window locks, fire extinguisher and two rear view mirrors.

Cab instrumentation — Standard illuminated instrument panel with speedometer, odometer, tachometer, voltmeter, hourmeter, low air pressure warning buzzer, push button starting switch, engine oil pressure gauge, air pressure gauge, water temperature gauge, and fuel gauge. Safety switch to prevent starting engine if transmission is not in neutral or if winch control valve is not in neutral.

Miscellaneous standard equipment
Front and rear fenders, back-up warning alarm, cab step, access ladder to carrier deck with hand grab, two front tow loops, and skid-resistant finish on carrier deck.

Miscellaneous optional equipment
Engine block heater, ether injection starting package, alcohol evaporator for air system, spare tire and rim assemblies.

Speed and gradeability^①

Engine	Speed range	Percent of gradeability
GM6-71N	2.79 to 50.59 m.p.h. (4.49 to 81.40 km/h)	37.58 to .66
Cummins NTCC-230*	2.55 to 46.19 m.p.h. (4.10 to 74.32 km/h)	41.48 to .68

^① Travel speed based on full load r.p.m. Gradeability based on peak torque of the engine.

Engine	GM 6-71N	Cummins NTCC-230*
Cylinders - cycle	6 - 2	6 - 4
Bore	4-1/4" (0.11 m)	5-1/2" (0.14 m)
Stroke	5" (0.13 m)	6" (0.15 m)
Displacement	426 cu.in. (7 146 cm ³)	855 cu.in. (14 013 cm ³)
Maximum brake h.p.	238 at 2,100 r.p.m.	230 at 2,100 r.p.m.
Peak torque	635 ft. lbs. (861.06 J)	650 ft. lbs. (881.40 J)
Electric system	12 volt negative ground	12 volt negative ground
Fuel capacity	100 gallons (378.5 L)	100 gallons (378.5 L)
Alternator	65 amp	65 amp
Crankcase capacity	30.5 quarts (33.59 L)	46 quarts (43.53 L)
Air compressor	12 c.f.m. (0.34 m ³ /min)	13.2 c.f.m. (0.37 m ³ /min)

*Optional Equipment

Axle loads

Base machine includes 35' - 90' (10.67 - 27.43 m) 3-section boom, 32' (9.75 m) two-piece fly, one winch with two-speed hoisting and power load lowering, 550' (168.71 m) 3/4" (19 mm) hoist line, FMC 8 x 4 carrier with GM 6-71 N diesel, Roadranger transmission and without counterweight:	G.V.W. ^①		Upper facing front				Upper facing rear			
			Front axle		Rear axle		Front axle		Rear axle	
	Lbs.	Kgs	Lbs.	Kgs	Lbs.	Kgs	Lbs.	Kgs	Lbs.	Kgs
	64,020	29 039	31,729	14 392	32,291	14 647	7,327	3 324	56,693	25 716
Counterweight for one winch	+ 6,900	+ 3 130	- 3,107	- 1 409	+ 10,007	+ 4 539	+ 4,680	+ 2 123	+ 2,220	+ 1 007
Counterweight for auxiliary winch	+ 5,800	+ 2 631	- 2,620	- 1 188	+ 8,420	+ 3 819	+ 3,943	+ 1 789	+ 1,857	+ 842
Auxiliary winch	+ 1 610	+ 730	- 316	- 143	+ 1,926	+ 874	+ 709	+ 322	+ 901	+ 409
60' (18.29 m) three-piece jib-stowed	+ 1,104	+ 501	+ 1,319	+ 598	- 215	- 98	- 1,049	- 476	+ 2,153	+ 977
Hook block at bumper	+ 800	+ 363	+ 1,237	+ 561	- 437	- 198	-	-	-	-
Headache ball at bumper	+ 215	+ 98	+ 333	+ 151	- 118	- 54	-	-	-	-
Auxiliary lifting sheave	+ 150	+ 68	+ 278	+ 126	- 128	- 58	- 241	+ 109	+ 391	+ 177
Base machine as above, but with 37' 6"-120' (11.43 - 36.58 m) 4-section boom and without counterweight.	67,470	30 604	36,177	16 410	31,293	14 195	5,664	2 569	61,806	28 035
Counterweight for one winch	+ 8,100	+ 3 659	- 3,659	- 1 660	+ 11,759	+ 5 334	+ 5,507	+ 2 498	+ 2,593	+ 1 176
Counterweight for auxiliary winch	+ 7,100	+ 3 221	- 3,207	- 1 455	+ 10,307	+ 4 675	+ 4,827	+ 2 190	+ 2,273	+ 1 031
Auxiliary winch	+ 1 610	+ 730	- 316	- 143	+ 1,926	+ 874	+ 709	+ 322	+ 901	+ 409
34' 6" (10.52 m) one-piece fly-stowed	+ 1,150	+ 522	+ 1,267	+ 575	- 117	- 53	- 986	- 447	+ 2,136	+ 969
30' (9.14 m) A-frame jib.	+ 1,160	+ 526	+ 1,065	+ 483	+ 95	+ 43	- 782	- 355	+ 1,942	+ 881
Hook block at bumper	+ 800	+ 363	+ 1,238	+ 562	- 438	- 199	-	-	-	-
Headache ball at bumper	+ 215	+ 98	+ 333	+ 151	- 118	- 54	-	-	-	-
Auxiliary lifting sheave	+ 150	+ 68	+ 312	+ 142	- 162	- 74	- 276	- 126	+ 426	+ 193
Bumper outrigger	+ 290	+ 132	+ 412	+ 187	- 122	- 55	+ 412	+ 187	- 122	- 55

^① Adjust gross vehicle weight and axle loading according to components weight.

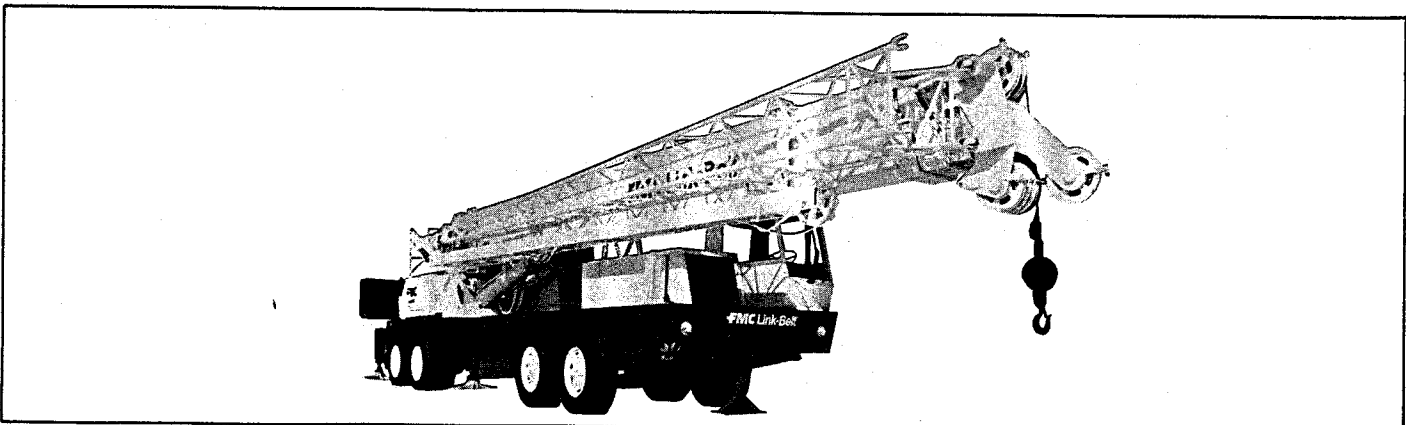

We are constantly improving our products and therefore reserve the right to change designs and specifications.

FMC Corporation Hydraulic Crane Division Lexington Kentucky 40512

Link-Belt* cranes/excavators manufactured in: Cedar Rapids Iowa • Lexington & Bowling Green Kentucky • Ontario Canada • Milan Italy • Queretaro Mexico & Nagoya Japan (under license)

