



Page 1 of 9
Date: Aug 2009
Replaces: Form BD106G
Dated: June 2006

The IC-20-1H is a self-propelled industrial crane designed for in-plant lifting and material handling applications. It is powered by either a dual fuel (gasoline/LPG) or diesel engine. The IC-20-H has special features of low height, narrow width, short length, cargo deck, rear wheel steer and front wheel drive. The basic unit consists of a chassis and hydraulic boom assembly. The chassis includes a frame, three hydraulic outriggers, oil tank, control station and full power steering. The boom assembly includes a hydraulic powered 90 degree swing turret, three section telescopic boom, hydraulic boom elevating cylinder, and hydraulic powered hoist.

IC-20-1H:

3-section hydraulically extended boom with capacity of 5,000 lb (2,270 kg) at a 4 ft (1.22 m) load radius. The main boom has a horizontal reach of 15 ft (4.57 m) from centerline of rotation and vertical reach of 21 ft (6.40 m).

General:

Length:

Chassis 9 ft 1 in (2.77 m)
Overall 9 ft 1 in (2.77 m)

Width:

4 ft (1.22 m)

Height:

Deck 28 in (.71 m)
Overall 5 ft 6 in (1.67 m)

Wheelbase:

4 ft 6 in (1.37 m)

Ground Clearance:

Chassis 8 in (20 cm)
Rear Axle (Minimum) 5 7/8 in (15 cm)

Angle of Approach:

28 degrees

Angle of Departure:

16 degrees

Turning Radius: (Minimum)

10 ft (3.05 m)

Aisle Width for 90-degree Turn: (Minimum)

7 ft 3 in (2.21 m)

Travel Speed: (Maximum)

5.5 MPH (8.9 km/h)

Weight:

6,380 lb (2,890 kg)

Weight Distribution:

Left-Hand Front Wheel 1,150 lb (520 kg)
Right-Hand Front Wheel 1,150 lb (520 kg)
Left-Hand Rear Wheel 1,260 lb (570 kg)
Right-Hand Rear Wheel 2,820 lb (1,280 kg)

Tire Footprint:

46 in² (297 cm²), each

Outrigger Footprint:

39 in² (252 cm²), each

Drawbar Pull:

3,000 lb (1,360 kg)

Gradeability:

53% (28 degrees)
Calculated gradeability value is based on GM 2.4L Gasoline engine.
Wheels may spin before these values are reached.

General: (Cont'd)**Grade Limit:**

Forward and backward	15%
Sideways with no load	10%

Boom Movement:

Rotation	90 degrees
Elevation	75 degrees
Telescope	9 ft (2.74 m)
Tailswing	2 ft 5-5/8 in (.75 m)

Boom Speed:

Rotation	10 seconds
Elevation	9 seconds
Telescope	25 seconds

Sheave Height:

Without Jib	21 ft (6.40 m)
With Jib	27 ft 9 in (8.46 m)

Horizontal Reach:

Without Jib	15 ft (4.57 m) C/L Rotation
	8 ft 8 in (2.64 m) Front of frame
With Jib	22 ft (6.71 m) C/L Rotation
	15 ft 8 in (4.78 m) Front of frame

ENGINE:**Standard:****GM 2.4L, Woodward EFI Dual Fuel, EPA Tier II Certified:**

Industrial gasoline engine complete with multi-port electronic fuel injection, dual fuel, and engine management system. Water-cooled, 4-cylinder, 147 CID (2.4 L), 3.44 in (8.74 cm) bore, 3.94 in (3.94 cm) stroke, 65 HP (48 kW) at governed speed of 2,500 RPM. Maximum torque 137 foot lb (186 n-m) at 2,300 RPM. 70-amp alternator, 13.5 gallon (51 L) gas tank, and 33 lb (15 kg) LPG tank. Includes high temperature, low oil pressure shutdown, and engine management system. Also includes a catalytic converter muffler.

Optional Engines and Accessories:**Cummins 2.3L, EPA Tier IV (Interim) Certified:**

Cummins Model A2300 diesel engine. Water-cooled, 4-cylinder, 140 CID (2.3 L), 3.46 in (8.79 cm) bore, 3.70 in (9.40 cm) stroke. 46 HP (34 kW) at governed speed of 2,600 RPM. Maximum torque, 110 foot lb (150 n-m) at 1,800 RPM. 45-amp alternator. (No weight change from gasoline engine)

Spark Arrester Muffler:

Spark arrester muffler used in addition to standard muffler. Net Weight: 10 lb (4.5 kg)

Engine Shutdown Kit:

Consists of Murphy switches that shut engine down if coolant temperature is excessive or oil pressure is too low. For diesel engine only.

Hydrostatic Transmission Pump:**Standard:**

Piston type, 2.8 CID (46 cm³) per revolution, direct driven from engine crankshaft. Maximum flow 30 GPM (114 l/m), maximum pressure 3,000 PSI (207 bar).

Axle:**Standard:****Front Axle:**

Channel shaped structure houses torque hubs, brakes and hydraulic drive motors. Front axle oscillates a total of 1-1/2 in (3.81 cm) to minimize wheel spin on uneven surfaces.

Rear Axle:

Fixed rigidly to frame. Box beam crossmember and thrust bearing supported wheel hubs.

Steering:**Standard:**

Full hydraulic unit controls 2-1/2 in (6.35 cm) steering cylinder attached to rear axle. Limited steering if engine dies.

Brakes:**Standard:**

Primary braking from hydrostatic transmission. Foot-actuated hydraulic disc brake for additional braking. Spring-applied, hydraulic-released park brake, actuated from a toggle switch on control panel. All braking is on front wheels.

Tires:**Standard:**

7.50 x 10 pneumatic tires, 16-ply. Pressurized to 145 PSI (1,000 kPa) for crane rated loads.

Optional Tire:**Solid Rubber Tires:**

For hazardous ground conditions. These tires do not change the overall height or ground clearance. Net Weight: 240 lb (109 kg)

Solid Rubber Non-Marking Tires:

Same as solid rubber tires except non-marking. Net Weight: 240 lb (109 kg)

Foam Filling of Tires:

Standard tires, foam filled to prevent flats. Net Weight: 312 lb (142 kg)

Spare Tire & Wheel:

7.50 x 10 pneumatic tires, 16-ply. Front or rear axle must be specified. Net Weight: 80 lb (36 kg)

Chassis:**Standard:****Cargo Deck:**

19 ft² (1.8 m²) area. A maximum of 5,000 lb (2,270 kg) may be carried on the deck when centered over front axle. Six stake pockets are provided in deck and six, one-inch (2.54 cm) diameter pipe stakes.

Optional Deck Mats:**Deck Mats:**

Rubber mats, 1/4 in (6.4 mm) thick, covering the three deck sections. Protects delicate loads from scratching and reduces sliding of heavy loads during travel. Net Weight: 40 lb (18 kg)

Outriggers:

Three hydraulic outriggers with box beam construction. Hydraulic cylinders are equipped with direct-connected holding valves. Pad dimensions are 6 in (15 cm) x 6 1/2 in (17 cm). Pulsating alarm sounds when outriggers are being operated.

Front Pulling Eye:

Heavy eye in front bumper provides for attachment of hook block so main winch line can be used for pulling loads at or near floor level.

Lifting Sling Brackets:

Two lift rings in front deck and lug on turntable for attaching lifting sling.

Optional Chassis Accessories:**Auxiliary Winch:**

Optional worm gear winch mounted behind front bumper, with a selector valve and single lever control at the operator's console. Hydraulic powered to provide bare-drum line pull of 3,000 lb (1,360 kg) at 20 ft (6.1 m) per minute. Winch drum is 3-1/2 in (8.9 cm) diameter by 6-1/4 in (15.8 cm) long. The winch includes 80 ft (24 m) of 5/16 in (7.9 mm) wire rope, hook and four-way roller guide. Net Weight: 130 lb (59 kg)

Pintle Hook:

T-60-A Holland 5-ton (4.5 tonne) pintle hook mounted on rear frame member. Net Weight: 7 lb (3.2 kg)

Lifting Sling:

Three-leg hitch consisting of heavy-duty pear link and three wire ropes with swaged-on clevis ends for attaching to lift points on crane chassis and turntable. Net Weight 10 lb (4.5 kg)

Rear View Mirrors:

One right-hand and one left-hand mirror, 6 in (15 cm) diameter, mounted on deck stakes. Pivot out of way when contacted by obstacle at side of deck. Net Weight: 12 lb (5.4 kg)

Operator's Compartment:**Standard:**

Operator control station provides one-position access to all chassis and crane functions.

Operator's Compartment Accessories:**Operator Guard:**

Tubular steel weldment with heavy expanded steel mesh top section, bolts over operator's compartment. Overall height with guard installed is 90 in (2.29 m). Net Weight: 60 lb (27.2 kg)

Floor mat:

Ribbed vinyl mat with foam backing for operator comfort.

Electrical System:**Standard:****Back-Up Alarm:**

Provides pulsating 97 decibel sound from solid-state alarm when ignition is on and transmission is in reverse.

Electrical Group:

12 Volt DC

Battery:

Group 24 with 550 CCA rating.

Lighting Group:

Consists of two headlights and taillight and 12 volt horn activated by button on instrument panel.

Instrument Group:

Located at operator's station and includes lighted fuel gauge, ammeter, oil pressure, water temperature and hydrostatic oil temperature gauges. Hourmeter records hours only during actual engine operation.

Optional Electrical Accessories:**Strobe Light:**

One yellow strobe light mounted on operator guard for high visibility. Flashes 60-120 times per minute. Draws 1/2 amp. Includes operator-controlled switch. When the operator guard is not ordered the strobe light is mounted on left-hand frame rail.

Boom Work Light:

Two work lights, one on left side of boom to light boom tip, and one on left side of turret to light ground under boom tip. Includes switch at operator's station. Net Weight: 10 lb (4.5 kg)

Hydraulic System:

Standard:

Tandem pump mounted to rear of hydrostatic piston pump, which is driven by the engine crankshaft. Delivers 6 GPM (23 l/m) at 2,500 PSI (172 bar) for boom circuits and 16 GPM (61 l/m) at 2,500 PSI (172 bar) for hoist and outrigger circuits. System protected by relief valves and two 10-micron filters. Hydraulic reservoir has 9.5 gallons (36 liters) capacity.

Boom Assembly:

Standard:

Three section, high strength steel construction, equipped with bearing pads for efficient support and extension. Double-acting hydraulic cylinders extend boom sections. The primary extension cylinder and the double-acting boom elevation cylinder are equipped with direct connected holding valves. Boom angle indicator provided on left side of boom.

Boom Swing:

Standard:

Two double-acting hydraulic cylinders are connected to turntable torque tube to provide 90 degrees of swing. Heavy-duty rotation bearing supports boom.

Optional Boom Swing Lock:

Boom Swing Lock:

Welds to back of frame and engages lug under turntable to hold boom in "over front" position and prevent boom from being swung in normal 90 degree arc. Net Weight: 12 lb (5.4 kg)

Boom Hoist:

Standard:

Turret-mounted, worm gear hoist is hydraulically powered to provide bare-drum line pull of 3,100 lb (1,400 kg). The IC-20 has a line speed of 63 ft (19.2 m) per minute. Hoist drum is 5-5/8 in (14.3 cm) diameter by 4-7/8 in (12.4 cm) long and provides even pull and long cable life. Hoist includes 80 ft (24 m) of 5/16 in (7.94 mm) wire rope, downhaul weight and swivel hook.

Boom Attachments:

Standard:

Anti-Two-Block Device:

Has electric solenoid dump valve which prevents damage to hoist rope and machine components from accidentally pulling load hook against boom tip. This valve will dump the **HOIST RAISE**, **TELESCOPE EXTEND** and **BOOM LOWER** circuits. No other circuits are affected. These circuits are returned to normal operations by operating the "hoist lower" or "telescope retract" control. This system uses a trip arm to activate switch.

Sheave Block:

Single sheave block for two-part line requirements. Six inch O.D. sheave for 5/16 in (7.9 mm) diameter wire rope. Swivel hook with safety latch. Fifty pounds (23 kg) of weight provides positive overhaul. Includes bar on top to actuate anti-two-block system.

Optional Boom Attachments:

7 Foot (2.13 m) Pin-On Jib:

Consists of jib with pair of tension bars, tip sheave, cable keeper, pins, jib attaching pins. Tension bars provide two positions, in-line and 30 degree offset. Net Weight: 97 lb (44 kg)

Rated Capacity Limiter:

Warns operator of impending overload with audible and visual signals. Prevents overload by stopping boom functions that cause overload. Readouts for load, boom angle, boom length and load radius. Net Weight: 30 lb (13.6 kg)

Should you require an option or special equipment not listed please consult your dealer salesperson or BMC®.

BRODERSON
Manufacturing Corp.
14741 West 106th Street
Lenexa, KS 66215 USA

Tel (913) 888-0606
Fax (913) 888-8431
www.bmccranes.com

Dimensions and values shown are
for reference purposes only.
Specifications subject to change.



LOAD RADIUS FEET	3-SECTION BOOM				7-FT. JIB ON RUBBER OR OUTRIGGERS
	FRONT ON RUBBER	FRONT ON OUTRIGGERS	LEFT SIDE ON RUBBER	LEFT SIDE ON OUTRIGGERS	
4	2500	5000	3800	5000	1300
5	2000	4000	3100	4000	1100
6	1500	3300	2500	3300	750
8	1400	2500	1500	2500	650
10	1300	2000	1000	2000	550
12	1200	1600	750	1400	500
15	1100	1200	500	1000	500
17					425
19					325
22					225

CAPACITIES ON OUTRIGGERS ARE 85% OF TIPPING LOADS. CAPACITIES ON RUBBER ARE 75% OF TIPPING LOADS.

CAPACITIES BELOW BOLD LINE ARE LIMITED BY TIPPING. OTHER CAPACITIES ARE LIMITED BY STRUCTURAL OR HYDRAULIC CAPACITY.

BOOM ANGLE MUST NOT BE LESS THAN 30° EXCEPT WHILE RIGGING IF THE JIB IS IN THE 30° OFFSET POSITION.

JIB DEDUCT: 150 LBS. IN WORKING POSITION WITH LOAD ON MAIN BOOM. ENSURE ANTI-TWO BLOCK SWITCH ON THE MAIN BOOM IS FUNCTIONING.

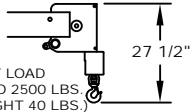

USE SINGLE PART LOAD LINE FOR LOAD TO 2500 LBS. (DOWNHAUL WEIGHT 40 LBS.)

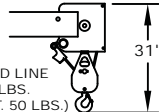

USE TWO PART LOAD LINE FOR LOAD TO 5000 LBS. (SHEAVE BLOCK WT. 50 LBS.)

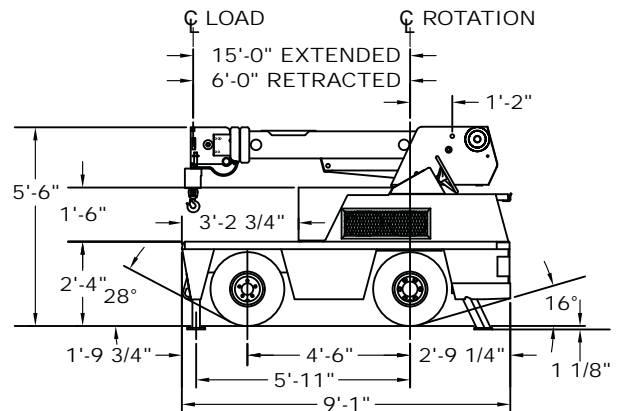
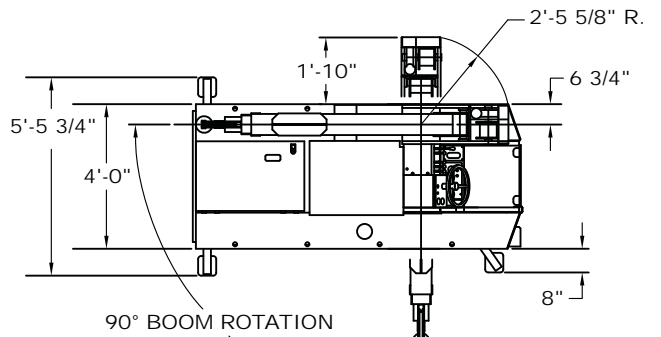
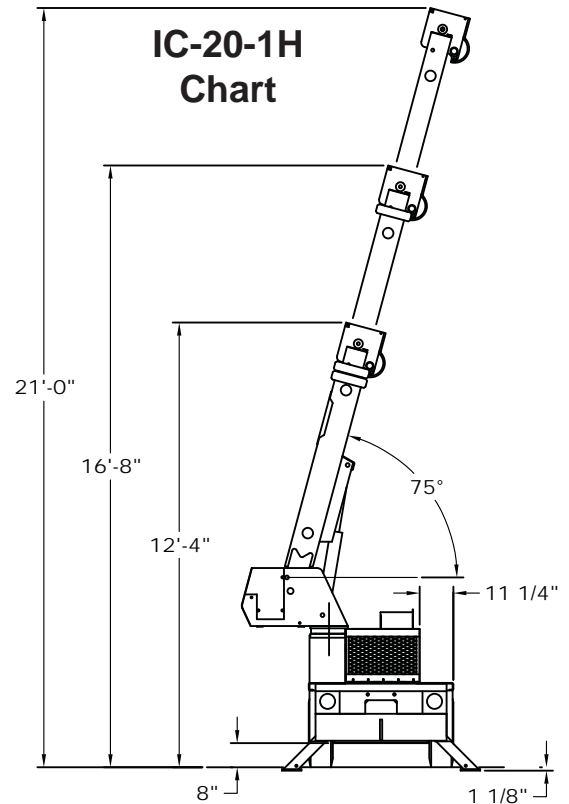
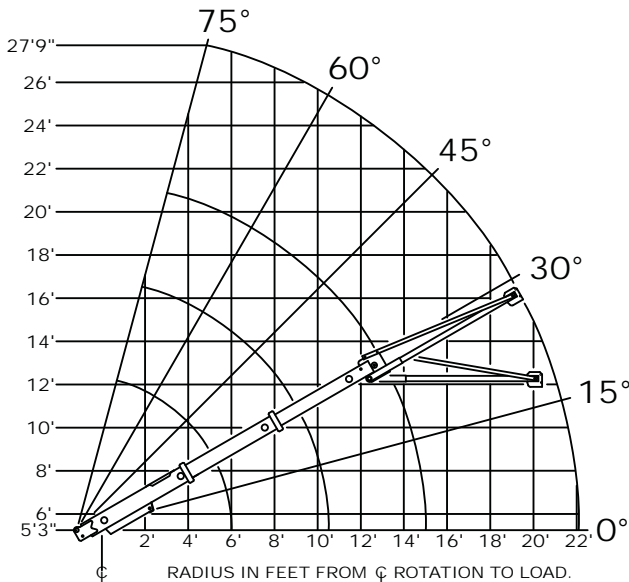
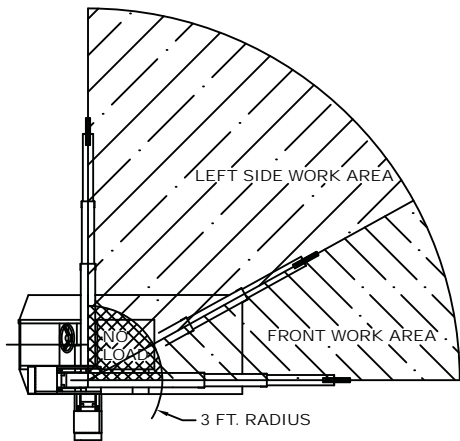

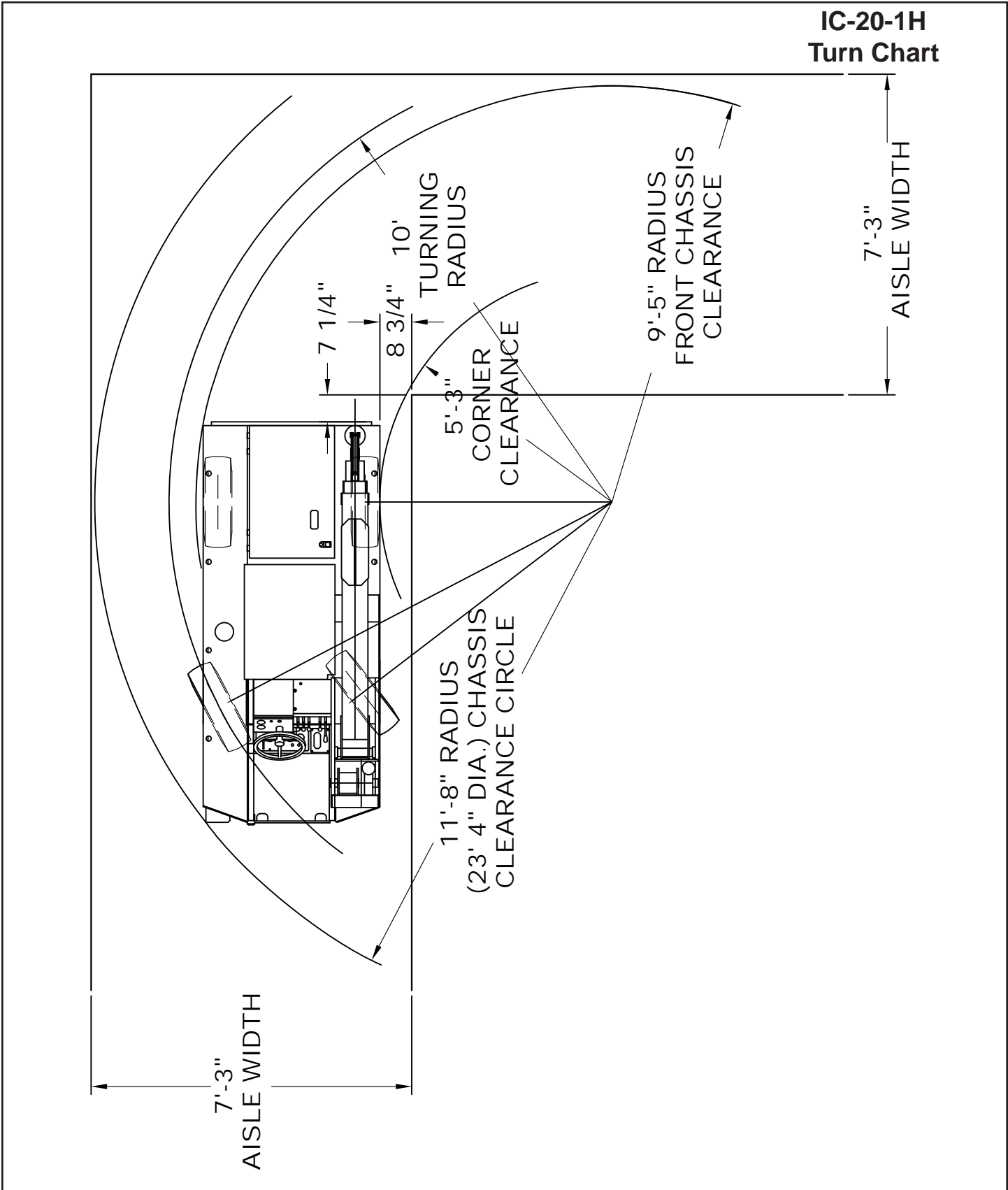

CAPACITIES IN KGS. FOR OPERATION ON FIRM LEVEL SURFACE

LOAD RADIUS METERS	3-SECTION BOOM				2.1M JIB
	FRONT ON RUBBER	FRONT ON OUTRIGGERS	LEFT SIDE ON RUBBER	LEFT SIDE ON OUTRIGGERS	ON RUBBER OR OUTRIGGERS
1.2	1130	2270	1720	2270	590
1.5	920	1840	1430	1840	510
2.0	670	1370	990	1370	310
2.5	630	1110	650	1110	290
3.0	590	920	460	920	250
3.5	550	770	370	700	230
4.0	520	660	290	530	220
4.5	500	550	230	460	220
5.0					200
5.5					170
6.0					130
6.7					100

CAPACITIES ON OUTRIGGERS ARE 85% OF TIPPING LOADS. CAPACITIES ON RUBBER ARE 75% OF TIPPING LOADS.

CAPACITIES BELOW BOLD LINE ARE LIMITED BY TIPPING. OTHER CAPACITIES ARE LIMITED BY STRUCTURAL OR HYDRAULIC CAPACITY.

BOOM ANGLE MUST NOT BE LESS THAN 30° EXCEPT WHILE RIGGING IF THE JIB IS IN THE 30° OFFSET POSITION.

JIB DEDUCT: 68 KGS. IN WORKING POSITION WITH LOAD ON MAIN BOOM. ENSURE ANTI-TWO BLOCK SWITCH ON THE MAIN BOOM IS FUNCTIONING.

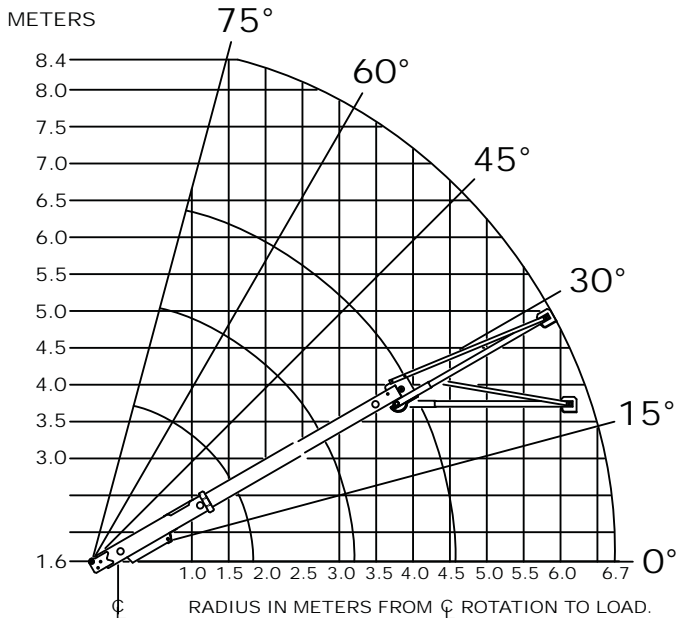
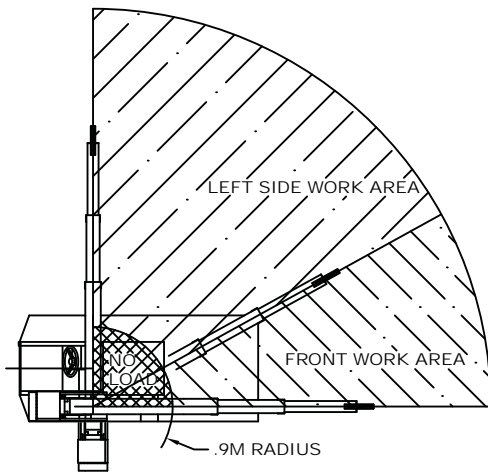
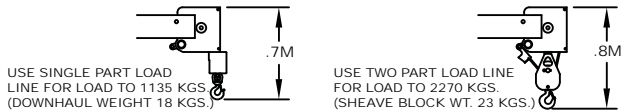

IC-20-1H
Metric Chart

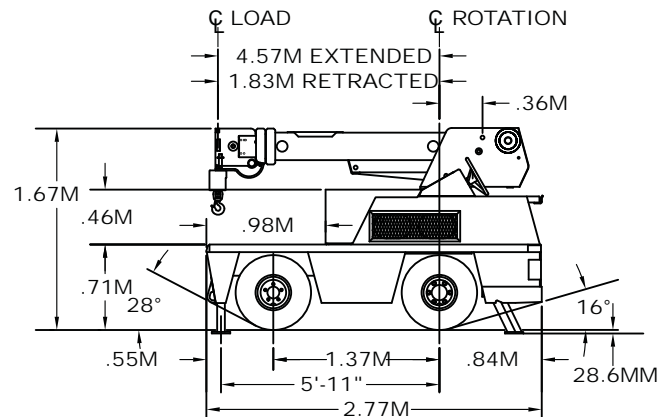
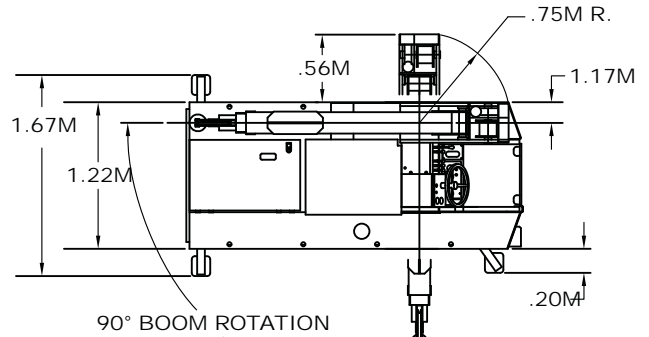
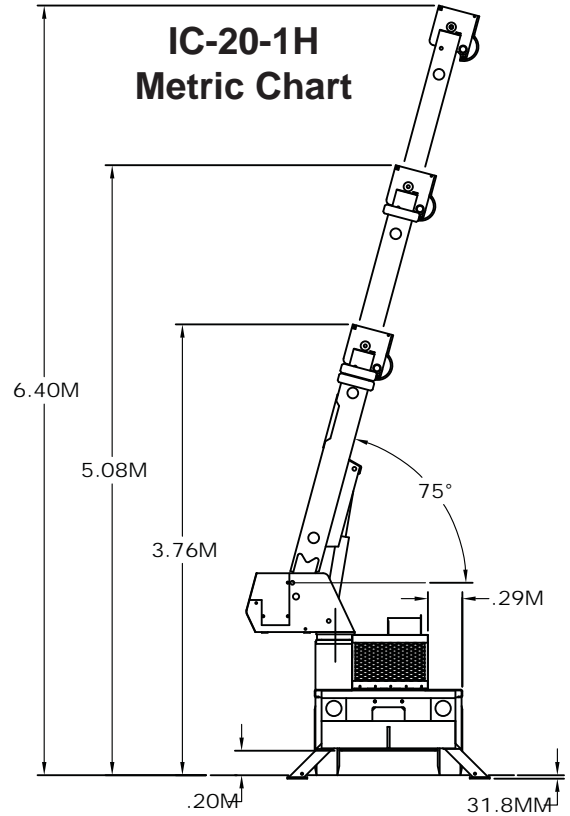

IC-20-1H
Metric Turn Chart

