



Model 6020 Crane

Volume 2 - PARTS AND SPECIFICATIONS

Section 1 CRANE SPECIFICATIONS

Section 2 CRANE REFERENCE

Section 3 REPLACEMENT PARTS

Section 4 GENERAL REFERENCE

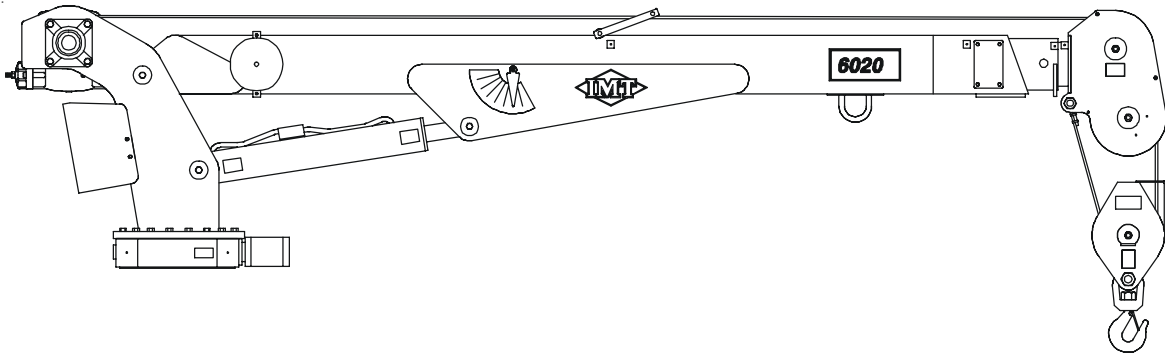

IOWA MOLD TOOLING CO., INC.

BOX 189, GARNER, IA 50438-0189

TEL: 641-923-3711

MANUAL PART NUMBER 99901220

Iowa Mold Tooling Co., Inc. is an Oshkosh Truck Corporation company.

REVISIONS LIST

DATE	LOCATION	DESCRIPTION OF CHANGE
20000811	3-52	ECN 9000:70733394-ADD APPLICATION NOTE
20000922	3-17	ECN 8504-51713182-ADD PIN O SOL PWR / DEL NOTE FOR AUTO TRANS
20001206	3-34	ECN9000-51705983-ADD 7Q072114 O-RINGS
	3-35	ECN9000-51705984-ADD 7Q072114 O-RINGS
20010115	3-18	ECN8648-93715067-REVISE MTG HRDWR & ADD SPACER
20010206	2-05	CORRECT SPARE PARTS LIST
20010403	2-06	UPDATED INSTALLATION KIT DRAWING
20010720	3-43, 51	ECN # 8723 - #5 73540044 WAS 73054936
20010726	3-44,45, 38, 39	ECN # 8733 - REVISED DRAWINGS
20011126	3-24-28, 30,32	ECN 8709 - CAST IRON HEAD & PISTON ON OUTRIGGER DN CYLINDER
20011126	4-1,14	ECN 8780 - WARRANTY
20011217	3-53	RMV BATTERY HOUSING FROM 70733354-1
	3-55	ECN 8827 - NEW CHASSIS WIRING HARNESS INSTALLATION
20020204	3-29	ECN 8726 - ITEM 8 NOW HEX
20020311	2-6, 3-18	ECN 8860 - CHANGES TO INSTALLATION KIT
20020514	3-5	CORRECTED ITEM 3, SEAL, PART NUMBER. WAS 76395168. NOW 70395076.
	3-56,57	ADDED 99900855 AND 09713879 TO SPARE PARTS MANUAL.
20020711	3-21	ADDED WELDMENT SPARE PARTS TO 18-GAL RESERVOIR ASM (51707798)
20020906	3-24, 35	ECN 8993 - NEW VALVEBANK 51714812
	3-32	CHANGE TO 3B205010 ITEM 13 - NOW 7T2N4035
20021024	3-53	ECN 9036 - CHANGED CHARGER ON 73733354
20021118	3-36	ECN 8733 - CHANGED RAD RMT BACKUP
20030916	3-38	51716912 BACKUP HANDSET - ADDED NOTE TO UNPLUG RADIO REMOTE
	3-44	73733383 - VALVEBANK - ADDED PLASTIC NUT PART NO.
	3-45-47, 54,55, 60	ECN 9211 - UPDATES TO CABLE ASM, 99900855 ELEC. SCHEM.
20031020	3-26, 35	ECN 9265 - CHANGE TO O/R 31712740, NEW VB 51714813
20040323	3-44,51	ECN 9397 - HYDRAULIC KIT CHANGES, 91715652-3 AND 91715633-3
20040827	3-37,44-50	ECN 9524 - NEW RADIO REMOTE, UPDATES TO HYD AND CONTROL KITS.
20040920	3-30	ECN 9569 - 31718953 REPLACED 31712733
20050712	3-6	ECN 9774 - REMOVED THREAD LOCK FROM #3 ON 41715305
	3-22	ECN 9776 - REMOVED HOOK HOLDER FROM 51706910 RESERVOIR
20051020	3-37	ECN 9931 - ADDED 2-SPEED WINCH SWITCH TO 90718833
20060112	3-4	ECN 9942 - CHANGE MOOR FROM 73051919 TO 73511070

INTRODUCTION

This volume deals with information applicable to your particular crane. For operating, maintenance and repair instructions, refer to Volume 1, OPERATION, MAINTENANCE AND REPAIR.

We recommend that this volume be kept in a safe place in the office.

This manual is provided to assist you with ordering parts for your IMT crane. It also contains additional instructions regarding your particular installation.

It is the user's responsibility to maintain and operate this unit in a manner that will result in the safest working conditions possible.

Warranty of this unit will be void on any part of the unit subjected to misuse due to overloading, abuse, lack of maintenance and unauthorized modifications. No warranty - verbal, written or implied - other than the official, published IMT new machinery and equipment warranty will be valid with this unit.

In addition, it is also the user's responsibility to be aware of existing Federal, State and Local codes and regulations governing the safe use and maintenance of this unit. Listed below is a publication that the user should thoroughly read and understand.

ANSI/ASME B30.5
MOBILE and LOCOMOTIVE CRANES
The American Society of Mechanical Engineers
United Engineering Center
345 East 47th Street
New York, NY 10017

Three means are used throughout this manual to gain the attention of personnel. They are NOTE's, CAUTION's and WARNING's and are defined as follows:

NOTE

A NOTE is used to either convey additional information or to provide further emphasis for a previous point.

CAUTION

A CAUTION is used when there is the very strong possibility of damage to the equipment or premature equipment failure.

WARNING

A WARNING is used when there is the potential for personal injury or death.

Treat this equipment with respect and service it regularly. These two things can add up to a safer working environment.

**Read and familiarize yourself with the
IMT OPERATOR'S CRANE SAFETY MANUAL
before operating or performing any maintenance
on your crane.**

SECTION 1. MODEL 6020 CRANE SPECIFICATIONS

GENERAL SPECIFICATIONS	3
PERFORMANCE CHARACTERISTICS	4
POWER SOURCE	4
ROTATION SYSTEM	4
CYLINDER HOLDING VALVES	4
EXCESSIVE LOAD LIMIT SYSTEM (ELLS)	4
WINCH	4
HYDRAULIC SYSTEM	4
MINIMUM CHASSIS SPECIFICATIONS	5
GEOMETRIC CONFIGURATION	5
CAPACITY CHART	6

MODEL 6020 CRANE SPECIFICATIONS

GENERAL SPECIFICATIONS

CRANE RATING	60,000 ft-lbs (8.4 ton-meters)
REACH - from centerline of rotation	20'-0" (6.10m)
HYDRAULIC EXTENSION	60" (152.4cm)
MANUAL EXTENSION	48" (121.9cm)
LIFTING HEIGHT - from base of crane	22'-1" (6.73m)
WEIGHT OF CRANE	1825 lbs (828 kg)
OUTRIGGER SPAN (required option) crane side from centerline of chassis	90" (228.6cm)
opposite crane side from centerline of chassis	48" (121.9cm)
STORAGE HEIGHT - crane only	37" (94cm)
MOUNTING SPACE REQUIRED (crane base)	20" x 21" (50.8cm x 53.3cm)
TIE-DOWN BOLT PATTERN	See Mounting Hole Pattern Drawing
HORIZONTAL CENTER OF GRAVITY - from centerline of rotation	34.5" (87.6cm)
VERTICAL CENTER OF GRAVITY - from bottom of crane base	21.5" (54.6cm)
OPTIMUM PUMP CAPACITY	10 U.S. Gallons/minute (38 liters/minute)
SYSTEM PRESSURE	3000 PSI (207 bar)
ROTATIONAL TORQUE	9000 ft-lbs (1245 kg-m)

PERFORMANCE CHARACTERISTICS

ROTATION:	400° (6.98 Rad.)	33 seconds
LOWER BOOM ELEVATION:	-10° to +80° (-0.17 Rad. to +1.40 Rad.)	11 seconds
EXTENSION CYLINDER:	60" (152.4cm)	8 seconds

POWER SOURCE

Integral-mounted hydraulic pump and PTO application. Other standard power sources may be used - minimum power required is 23.5 horsepower based on 10 GPM at 3000 PSI (38 liters/min. at 207 bar).

ROTATION SYSTEM

Turntable bearing powered by a high-torque hydraulic motor through a self-locking worm. Total gear reduction is 85 to 1.

CYLINDER HOLDING VALVES

The base end of the extension cylinder is equipped with a pilot operated locking holding valve to prevent sudden cylinder collapse in the event of a hose breakage or other hydraulic component failure.

The extend side of the lower boom cylinder is equipped with a counter balance valve. The counter balance valve serves several functions. First, it is a holding valve. Secondly, it is designed to control the speed at which the lowering function operates, and allows that motion to be metered under load. Finally, it prevents the loss of an excess amount of oil in the event of a hose failure. Only the oil in the hose, at the time of the failure, will be lost.

EXCESSIVE LOAD LIMIT SYSTEM (ELLS)

Overloading of the crane is limited by the ELLS. This is done by disarming the crane functions which make possible the application of greater than allowable stress to the crane structure and components. Functions controlled by the ELLS are winch up, extension out and lower boom down. To relieve the situation, the operator may set the load down (winch down) or retract the extension boom (extension in).

WINCH

The winch is powered by means of a hydraulic motor driving a 27:1 worm gear arrangement with a mechanical brake. Maximum single line lifting capacity of the winch, achieved on the second layer of wire rope, is 5500 lbs. (2495 kg.). Maximum two-part line winch capacity is 10,400 lbs. (4717 kgs). The winch is equipped with 100 ft. (30.5 m) 7/16 in. (1.1 cm) 6 x 25 FW PRF RRL IWRC XIPS wire rope. Nylon sheaves are located at the tip of the extension boom. The ratio of winch drum and sheave pitch diameter to wire rope diameter is 18.7:1 for the winch drum and 18:1 for the load block and boom tip sheave. An anti-two block device is included to prevent the lower block or hook assembly from coming in contact with the boom sheave assembly.

SINGLE LINE SPEED

1st Layer - 25 ft/min
 2nd Layer - 27 ft/min
 3rd Layer - 30 ft/min

HYDRAULIC SYSTEM

The hydraulic system is an open center, full pressure system requiring maximum flow of 10 GPM (38 liters/min.) at 3000 psi (207 bar). It is equipped with a four section, electric remote, stack type control valve with a 30 ft. (9.14 m) control cable. The system includes a separate hydraulic oil reservoir, suction line filter, return line filter and control valve.

MINIMUM CHASSIS SPECIFICATIONS

BODY STYLE	Conventional Cab	Conventional Cab
WHEEL BASE	154"	391cm
CAB TO AXLE	84"	213cm
FRAME SECTION MODULUS	12 cubic inches	196.7cc
RBM	600,000 in-lbs	6913 kg-meter
FRONT AXLE RATING	7000 lbs	3175 kg
REAR AXLE RATING	17500 lbs	7938 kg
GROSS VEHICLE RATING	24500 lbs	11113 kg
TRANSMISSION	5 speed	5 speed

In addition to these specifications, heavy duty electrical and cooling systems are required. It is recommended that the vehicle be equipped with an engine tachometer, auxiliary brake lock, and power steering.

IMT reserves the right to change specifications or design without notice.

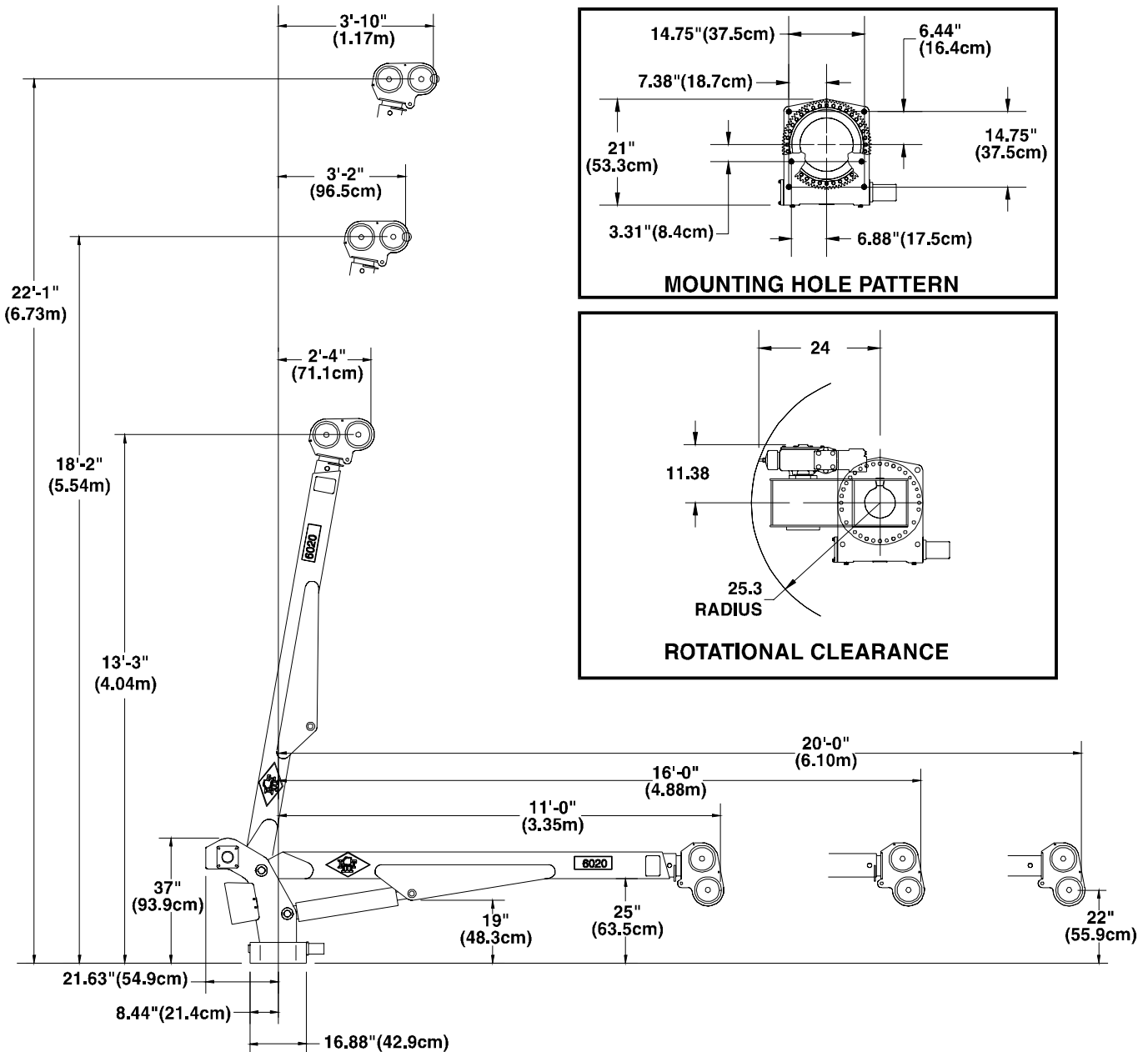

GEOMETRIC CONFIGURATION

6020 CAPACITY CHART

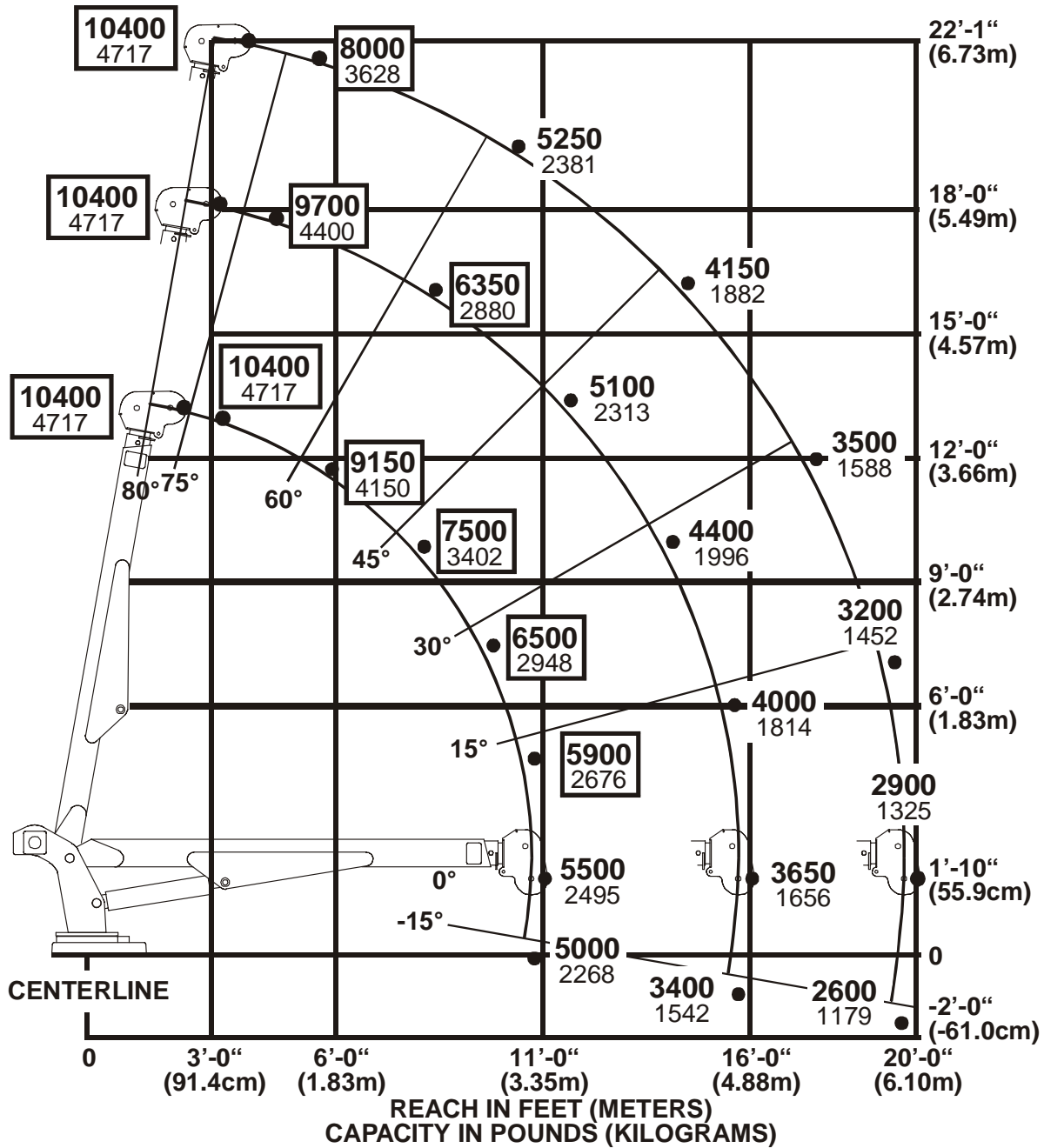

Maximum 1-part line capacity is 5500 lbs (2495 kgs).
 For greater loads, use 2-part line.

Weight of load handling devices are part of the load lifted and must be deducted from the capacity.



IOWA MOLD TOOLING CO., INC.

BOX 189, GARNER, IA 50438-0189

TEL: 641-923-3711 FAX: 641-923-2424

70395099

SECTION 2. MODEL 6020 CRANE REFERENCE

MAJOR CRANE ASSEMBLIES	3
WELDMENT PART NUMBER LOCATIONS	3
GREASE ZERK LOCATIONS & LUBRICANT REQUIREMENTS	4
RECOMMENDED SPARE PARTS LIST	5
CONTROL VALVE TROUBLESHOOTING	8
RELAY BOARD OPERATION	10
FLIP-UP BOOM SHEAVE	16
WINCH TROUBLESHOOTING	18
ANTI TWO-BLOCKING DEVICE	19
Excessive Load Limit System (ELLS) TEST PROCEDURE	21
ELLS TROUBLESHOOTING PROCEDURE	26

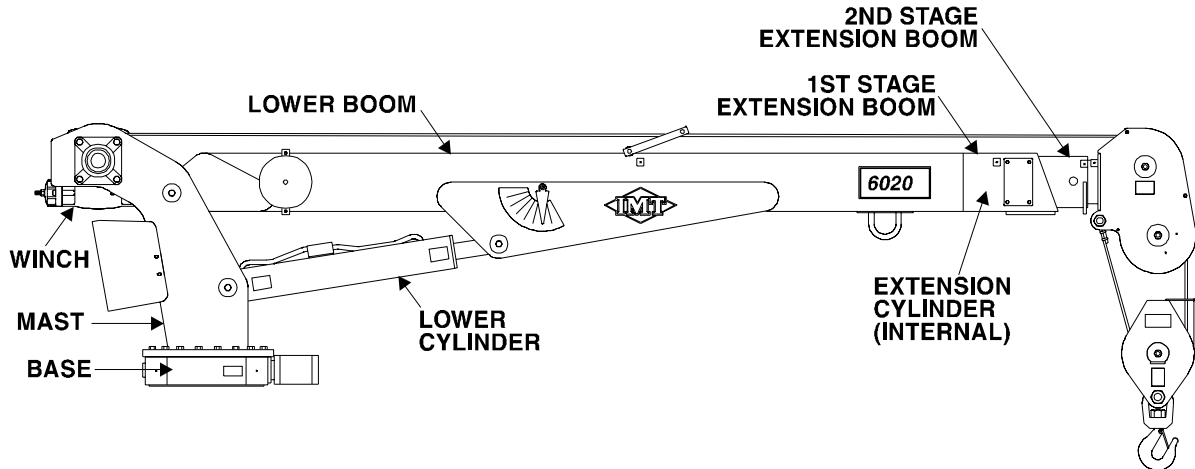

MAJOR CRANE ASSEMBLIES

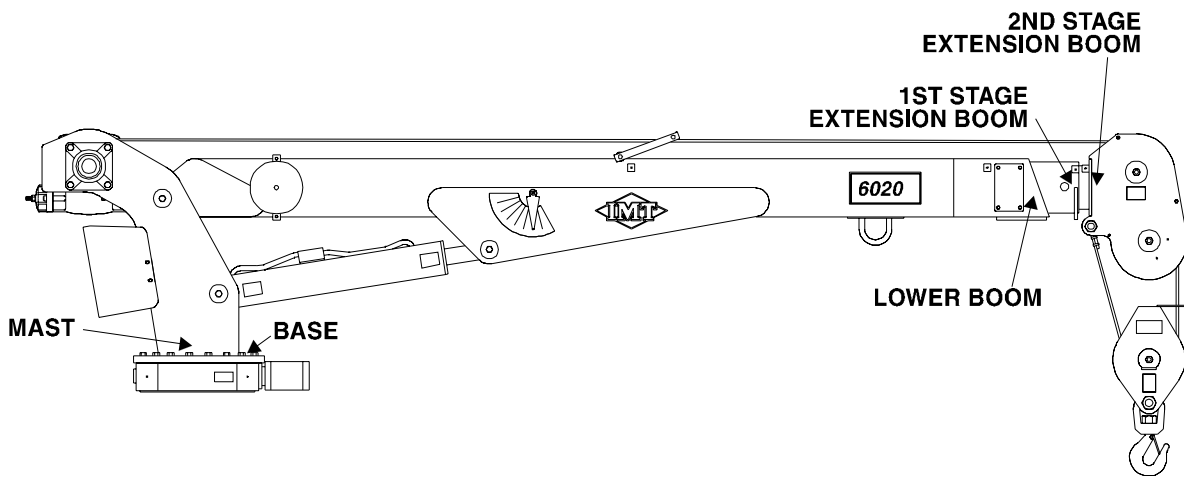

WELDMENT PART NUMBER LOCATIONS

GREASE ZERK LOCATIONS & LUBRICANT REQUIREMENTS

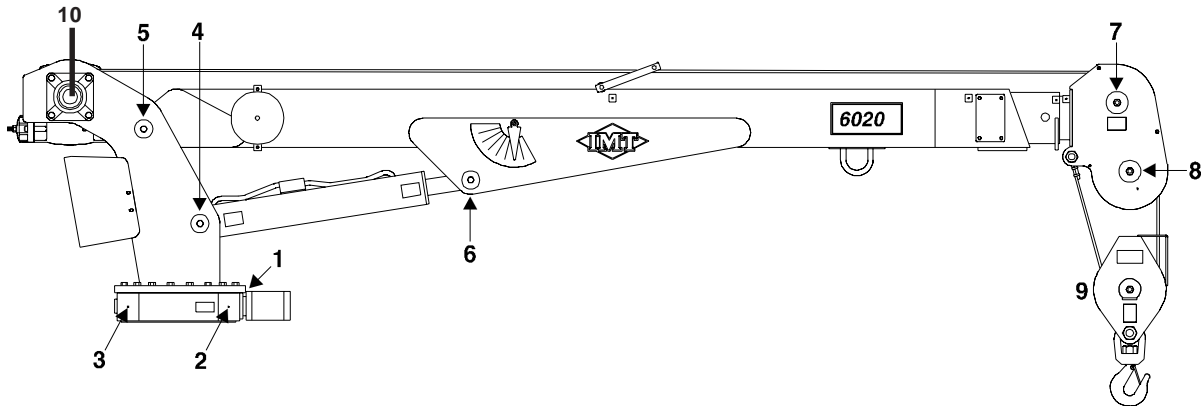

ITEM	LOCATION DESCRIPTION	LUBRICANT	FREQUENCY
1. 4. 5. 6. 7. 8. 9. 10.	TURNTABLE/BEARING GREASE EXTENSION *ROTATE CRANE WHILE GREASING LOWER CYLINDER BASE MAST/LOWER BOOM HINGE PIN LOWER CYLINDER ROD UPPER SHEAVE PIN LOWER SHEAVE PIN SNATCH BLOCK PIN WINCH BEARING	SHELL ALVANIA 2EP OR SHELL RETINAX "A"	WEEKLY
2. 3.	WORM GEAR (FWD)* WORM GEAR (REAR)* * Apply 3 "pumps" the rotate crane fully	EXTREME PRESSURE EP2 GREASE	EVERY 3 MONTHS

NOTE: All application points except 2 & 3 must be greased weekly under normal work loads and moderate weather conditions. Under severe operating conditions, lubrication should be performed more frequently. See Volume 1; Operation, Maintenance and Repair for additional lubrication requirements.

RECOMMENDED SPARE PARTS LIST**1 YEAR SUPPLY****MODEL 6020 TELESCOPING CRANE****FOR MANUAL: 99901220**

This spare parts list does not necessarily indicate that the items can be expected to fail in the course of a year. It is intended to provide the user with a stock of parts sufficient to keep the unit operating with the minimal down-time waiting for parts. There may be parts failures not covered by this list. Parts not listed are considered as not being Critical or Normal Wear items during the first year of operations and you need to contact the distributor or manufacturer for availability.

ASSEMBLY DESIGNATION	ITEM NO.	PART NO.	DESCRIPTION	QTY	CODE	SHELF LIFE (MO)	ORDER QTY
41715069.01.19990104	BASE ASM						
	2	73051919	HYD MOTOR	1	C		
71056551.01.19990104	GEAR ROTATOR						
	2	70395074	O-RING	1	W		
	3	76395168	SEAL	2	W		
	4	70145846	SNAP RING	1	W		
	5	70055271	BRG-CONE	2	W		
	6	70055281	BRG-CUP	2	W		
	7	70145501	BRG RETAINER	1	W		
	8	70056550	WORM	1	C		
	15	73145506	SHIM .005	2	W		
	16	73145505	SHIM .015	2	W		
	17	73145504	SHIM .030	2	W		
	18	76039295	GASKET	1	W		
41712180.01.19990104	LOWER BOOM ASM						
	5	7BF81520	BUSHING	4	W		
	6	60030015	WEAR PAD	2	W		
	7	60030139	WEAR PAD	1	W		
3C126990.01.19991216	LOWER BOOM CYLINDER						
	3	7BF81520	BUSHING	6	W		
	6	6I503181	PISTON	1	W		
	7	6H050025	HEAD	1	W		
	8	9B043920	SEAL KIT	1	W		
	21	73540035	C'BAL VALVE	1	W		
41707663.01.19990104	EXTENSION BOOM ASM						
	5	60030189	WEAR PAD	1	W		
3B309820.01.19990104	EXTENSION BOOM CYLINDER						
	4	6H025015	HEAD	1	W		
	5	6IX02512	PISTON	1	W		
	9	73054900	HOLDING VALVE	1	C		
	10	9B101220	SEAL KIT	1	W		
41709440.01.19990104	EXTENSION BOOM W/FLIP SHEAVE						
	5	60030189	WEAR PAD	1	W		
73054900.01.19990104	LOCKING HOLDING VALVE						
	2	73054999	C'BALANCE VALVE	1	C		
	3	7Q072112	O-RING	3	W		
41712179.01.19990104	WINCH/CABLE/HOOK KIT						
	6	60030255	SHEAVE	3	W		
	12	70055117	FLANGE BEARING	1	W		
	16	70732882	HOOK	1	C		
	42	51713168	CORD REEL	1	W		
31712207.01.19990104	WINCH/CABLE/HOOK KIT-FLIP SHEAVE						
	6	60030255	SHEAVE	3	W		
	12	70055117	FLANGE BEARING	1	W		
	16	70732882	HOOK	1	C		
	42	51713168	CORD REEL	1	W		
70570198.01.19990104	WINCH						
	11	76393419	OIL SEAL	1	W		
	12	70143948	BUSHING	1	W		
	13	70143949	BUSHING	1	W		
	17	76393420	O-RING	1	W		
	23	76394300	GASKET	1	W		
	25	76393171	GASKET	1	W		
51713182.01.19990104	PROPORTIONAL REMOTE HANDLE ASM						
	16	77040371	TOGGLE SWITCH SPST	2	W		
	17	77040372	TOGGLE SWITCH SPDT	4	W		
	18	77040373	TOGGLE SWITCH SPST	2	W		
	19	77040374	TOGGLE SWITCH SPDT	1	W		
	REF	73052006	ELEMENT-RET. FILTER 10MIC	6	P		

INSTALLATION

GENERAL

This section contains instructions for the installation of your crane. Prior to installing the crane and hydraulic components, make sure that the chassis is ready to receive the crane (refer to Section 5, Volume 1). Reinforce the chassis frame, as necessary, and install the PTO and pump.

Each installation may vary in components used. It is important to use hoses of proper length, pumps of correct size, and PTO's of adequate speed. Study the applicable installation kit in the parts section before attempting any installation.

CRANE INSTALLATION

In addition to meeting Minimum Chassis Specifications in Section 1, there must be sufficient room for mounting the crane and the platform must be strong enough to support the crane and rated load. Install the crane only on an IMT designed and approved truck body. The body must be designed to sustain the forces imposed by the crane when lifting the full rated load. In addition, an IMT designed body is designed to take full advantage of the standard reservoir placement. This reservoir is installed in the cargo area of the body. Before attempting to install the crane, the body must be installed. To install the crane:

1. Use a lifting device capable of lifting the weight of the crane. See Specifications Section for crane weight. Attach fabric slings to the crane lower boom, centered approximately 18 inches from the mast hinge. Make certain the crane is well balanced on the slings by slowly lifting approximately 6" off the ground. Lift the crane, apply a bead of waterproof compound, such as silicon based caulk, to the bottom of the base. Move the chassis under the crane and lower the crane into the desired position.

2. Install the 1-8x3" mounting cap screws (use Permanent Thread Lock) and 1" washers to secure the crane base to the truck body (see Figure below). Torque the cap screws to 680 ft-lbs (94 kg-m).

CAUTION

The 3" bolts supplied for use on bodies with a crane box top plate thickness of 7/8-1" only. Determine the crane box top plate thickness prior to mounting. If different length bolts are required, they must be 1-8, grade 8, zinc coated of the proper length. Failure to use proper length bolts may cause the bolts under the worm housing to bottom out before torquing. Insure a minimum of 1-1/2" thread engagement.

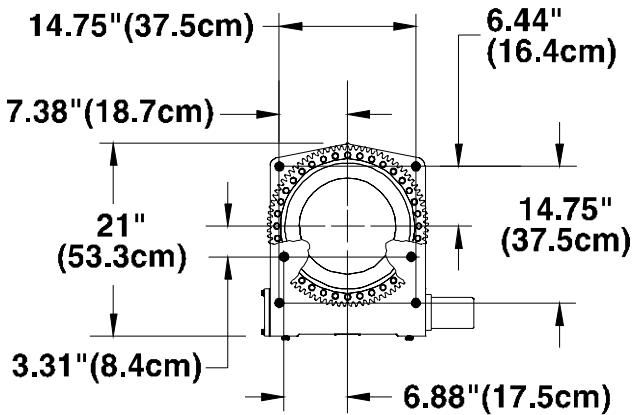

MOUNTING HOLE PATTERN

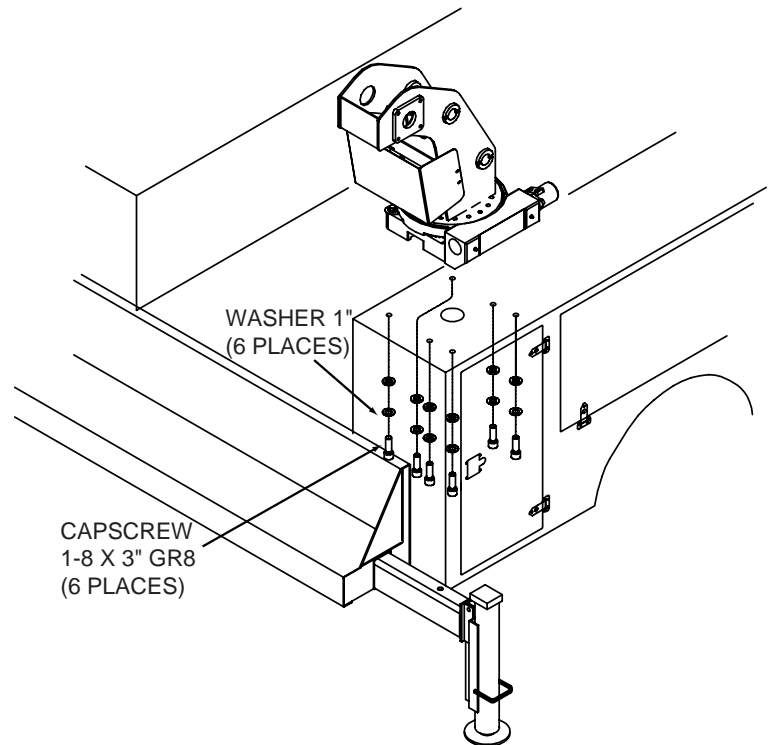

CRANE INSTALLATION

HYDRAULIC INSTALLATION

Before installation, familiarize yourself with the installation kit drawing in the parts section for specific hydraulic components used. The figure below is used to show major components and general hose routings only.

1. Plumb the hydraulic components as shown in the applicable installation kit in the parts section. Make certain all fittings are securely tightened and that hoses are free of possible chafing or contact with hot or sharp edges which could cause damage.

2. Refer to Volume 1 for hydraulic oil specifications. Fill the hydraulic reservoir.

3. Check all connections for leaks.

4. Start the vehicle engine and test each crane function individually. Conduct a visual inspection to make certain that there are no leaks and that everything is operating properly.

5. Check oil level in the reservoir and add oil if necessary.

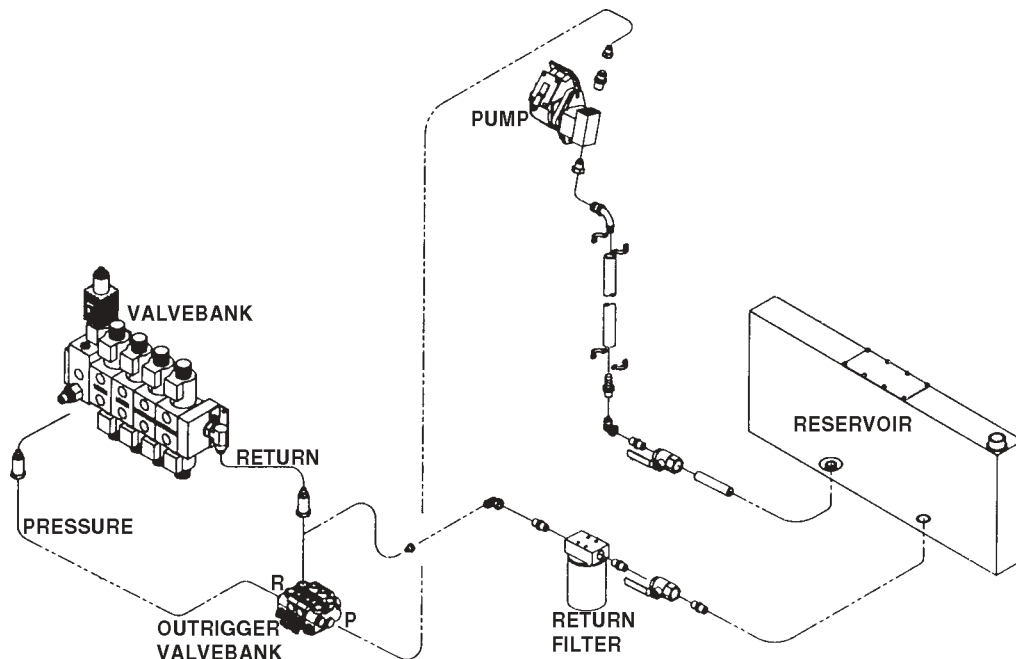

HYDRAULIC INSTALLATION

CONTROL VALVE TROUBLESHOOTING

GENERAL

This section describes the operating characteristics of the main control valvebank used on this model of crane. It also provides troubleshooting information which applies to this valvebank. See figure on following page for reference.

ELECTRICAL-AMP DRIVER

POWER LED

The Power LED illuminates red while power is being applied to the valve amplifier. If the LED is not illuminated, no power is being applied to the valve amplifier.

If the Power LED does not function as described, inspect input wiring and repair or replace as necessary. When input power is applied, the LED should illuminate.

PMW% LED

The PMW% LED indicates the condition of the output current flowing to the proportional valve. The LED will change colors from, red to yellow to green. The change of colors indicates the variance of current flowing to the proportional valve. Red indicates minimum current and green indicates maximum current. This represents the flow condition going from low flow (red) to maximum flow (green), thus varying the speed of crane functions.

If the LED stays red, as the speed control trigger is activated, a dead short is present in the circuit. This could be the result of a wiring problem, shorted out proportional coil, etc. Inspect the wiring and replace the proportional coil, if required.

MIN POTENTIOMETER

The Min adjustment pot will be used to set the minimum amount of movement of an individual function at the valvebank when the corresponding function switch at the handset is depressed. To adjust, set engine at high speed control setting. Depress the "Rotation" function switch at the handset. Adjust the Min pot at the AMP driver card clockwise until crane begins to rotate or counterclockwise until motion begins to stop. No other electrical adjustments are required to properly operate the crane.

HYDRAULICS-VALVEBANK

RELIEF VALVE

The relief valve limits the maximum system pressure. Pressure limits the amount of torque or force an actuator will see. This pressure is preset to 3000 psi at 10 gpm. If the relief valve should fail, it would likely stick open. This would prevent system pressure from developing and cause a lack of torque/force at the actuator. The relief valve can be changed easily by screwing it out and replacing with a new one.

PROPORTIONAL VALVE

The proportional valve varies the oil flow to the individual crane functions. Doing so dictates the speed of the crane functions. As the electrical current increases to the valve, by using the trigger on the control handle, more oil is ported downstream to the crane function. If the valve coil burns out, the operator would be unable to vary the flow to the crane functions. If the valve spool becomes stuck, the operator would be unable to vary the downstream flow. If speed control is the problem, it is likely an indication of a proportional valve problem. It is necessary to verify that current is flowing to the coil correctly, and that it is not an electrical problem.

The proportional valve can also be operated manually for test purposes. The valve stem can be screwed in manually to port oil downstream. Doing so will manually position the valve spool and hold it in the manually commanded position.

DIRECTIONAL VALVES

The directional valves (4) control the direction of the crane functions. When one of the solenoids is energized, it shifts the valve spool. This allows oil to flow out one of the valve ports. If a function does not work, a directional valve may be to blame.

These valves have a standard manual override. You may manually shift the valve by pushing the pin, located in the middle of the solenoid.

CAUTION

MANUALLY OVERRIDING A DIRECTIONAL VALVE WILL PORT OIL IMMEDIATELY TO THE VALVE FUNCTION. THIS WILL CAUSE A SUDDEN MOVEMENT OF THE ACTUATOR. OPERATORS AND MAINTENANCE PERSONNEL MUST KEEP THE WORK AREA CLEAR OF OTHER PERSONNEL WHEN OVERRIDING A DIRECTIONAL VALVE.

If the valve shifts using manual overrides, the problem is of an electrical nature. Valve coils are interchangeable and may be changed by removing the coil nut. This allows maintenance personnel to isolate individual coil failures. If the valve cannot be actuated manually or electrically, it is necessary to replace the section.

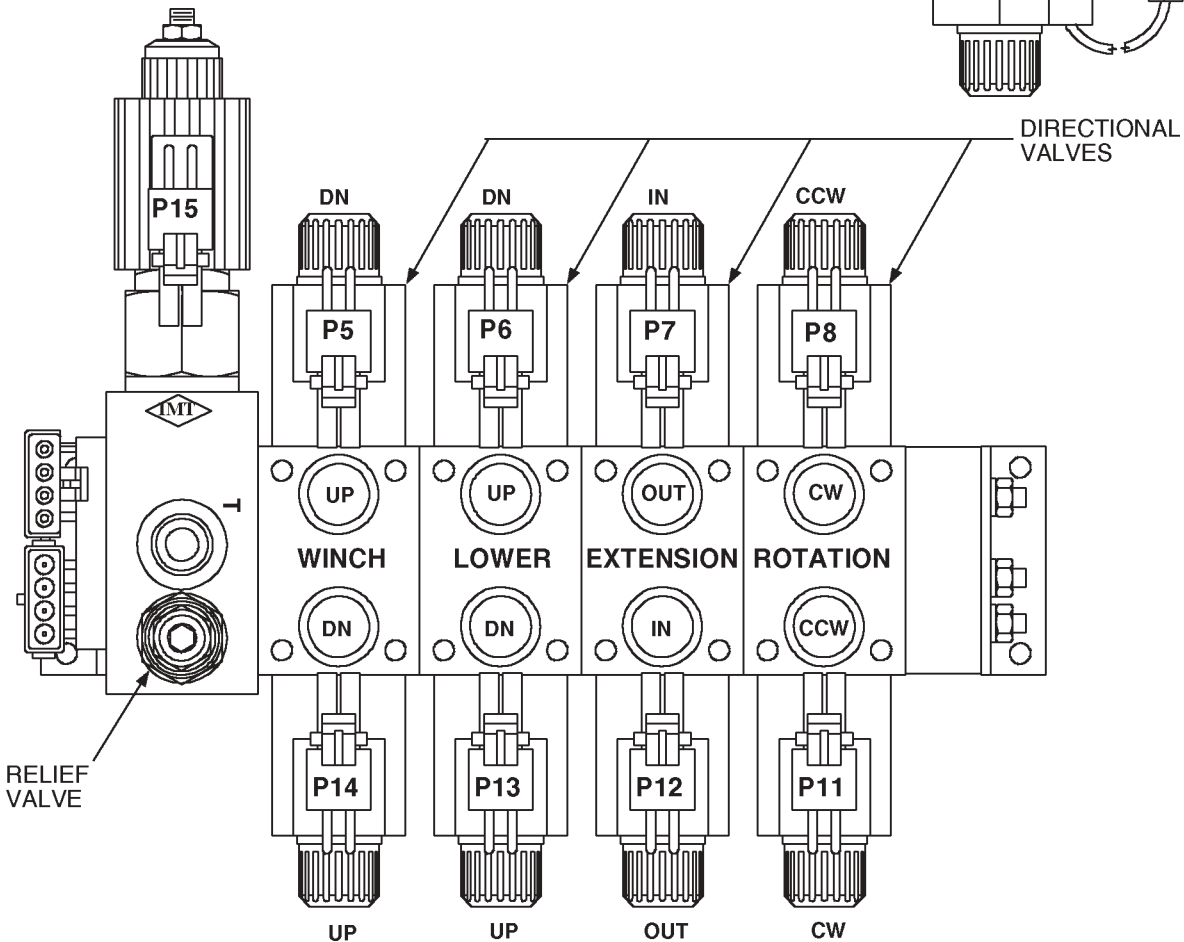
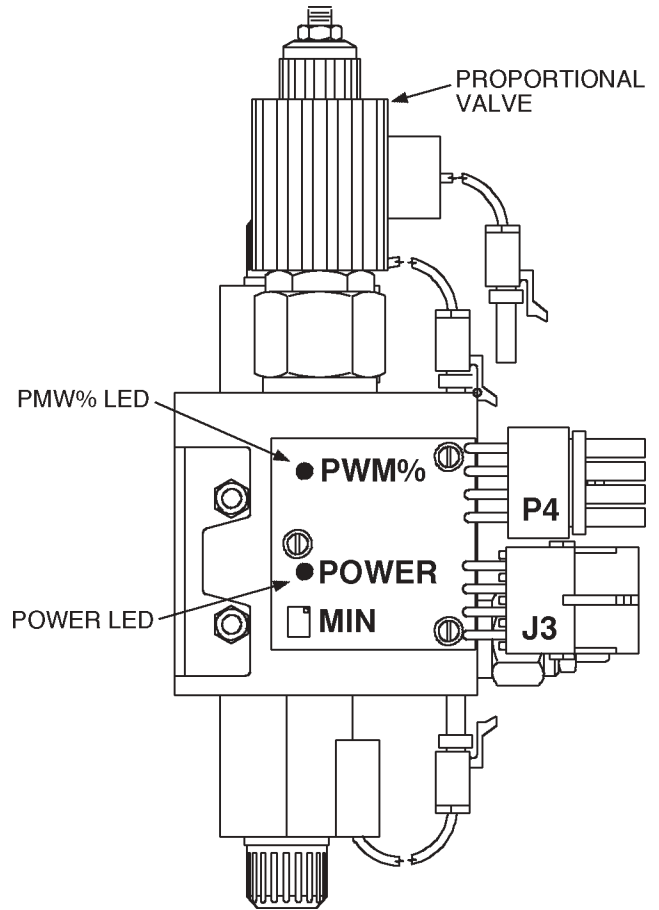

VALVEBANK

RELAY BOARD OPERATION

INTRODUCTION

To understand how the relay board operates, it is necessary to understand how the individual relays function.

The Bosch relay (part number 77041251) is a normally open relay between terminals 30 and 87 and normally closed between terminals 30 and 87a. Terminals 85 and 86 energize the relay through the coil. See Figure 1 and 2.

Figure 3 shows the relay board with eight relays identified with the letters "A" through "G" and by their basic function. Example: Relay "A" is the "Power ON/OFF" relay, "C" is the "Compressor Speed Control", etc. The small numbers shown on the individual terminals of the relay indicate where that terminal is connected through the circuit board, to the terminal bar. Example: Relay "A" top terminal (#9) is connected to terminal 9 of the terminal bar. The terminal bar is provided with 16 individual terminals of which the last two (15 and 16) are not used. Wires connected to the terminal bar have been identified according to their function in the circuit. The number of terminals used vary with each application. Solid lines between relay terminals indicate existing wiring connections, through the circuit board.

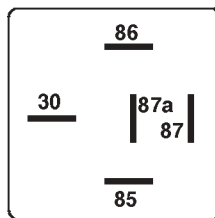

FIGURE 1. BOTTOM VIEW OF RELAY

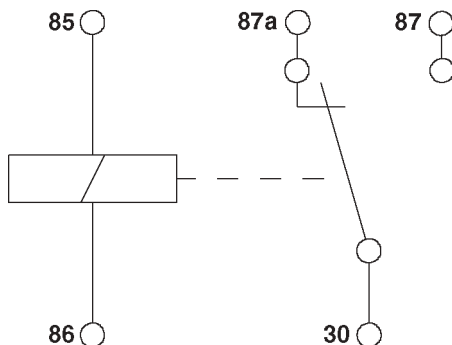

FIGURE 2. INTERNAL WIRING

The relay board is primarily used on vehicles with remote controlled cranes and remote control cranes and compressors. The circuitry prevents remote starting of the truck engine unless the brakes are applied and the PTO is engaged. It also isolates the crane speed control from the compressor speed control.

OPERATION

IGNITION "ON"

When the ignition switch of the vehicle is turned "ON", terminal 9 of the terminal bar is "HOT". The coil of relay "A" is energized and voltage from terminal 1 of the terminal bar becomes present at terminals "A", "B", "E" and "H". See Figure 3.

REMOTE STARTING THE VEHICLE

The vehicle can be remotely started from the remote control handle by toggling the "Crane-OFF-Compressor" switch to the "Crane" position.

To start the vehicle, the engine start switch at the handle must be depressed. When this is accomplished, terminal 11 of the terminal block becomes "HOT". See Figure 5.

The truck starter is energized when terminals 11 and 12 of the terminal bar are connected through the relay board. When terminal 11 is "HOT", the coil in relay "F" is energized connecting relay terminal 12 and "B" on relays "F" and "G". If terminal 14 of relay "H" and terminal 13 of relay "G" are grounded (brakes and PTO engaged) terminals "B" of relays "F" and "G" are "HOT". Since terminal "B" of relay "F" is "HOT", the truck starter solenoid is activated. Energized circuits are shown as bold in Figure 5.

REMOTE ENGINE STOP

When the engine stop button is depressed on the remote control handle, voltage is applied to terminal 6 of the terminal block and of relay "D". The coil in relay "D" is energized and the ground of the fuel solenoid/distributor coil is interrupted because current can no longer flow from terminal 7 to 8. Relay "D" is normally closed between terminals 7 and 8. See Figure 3.

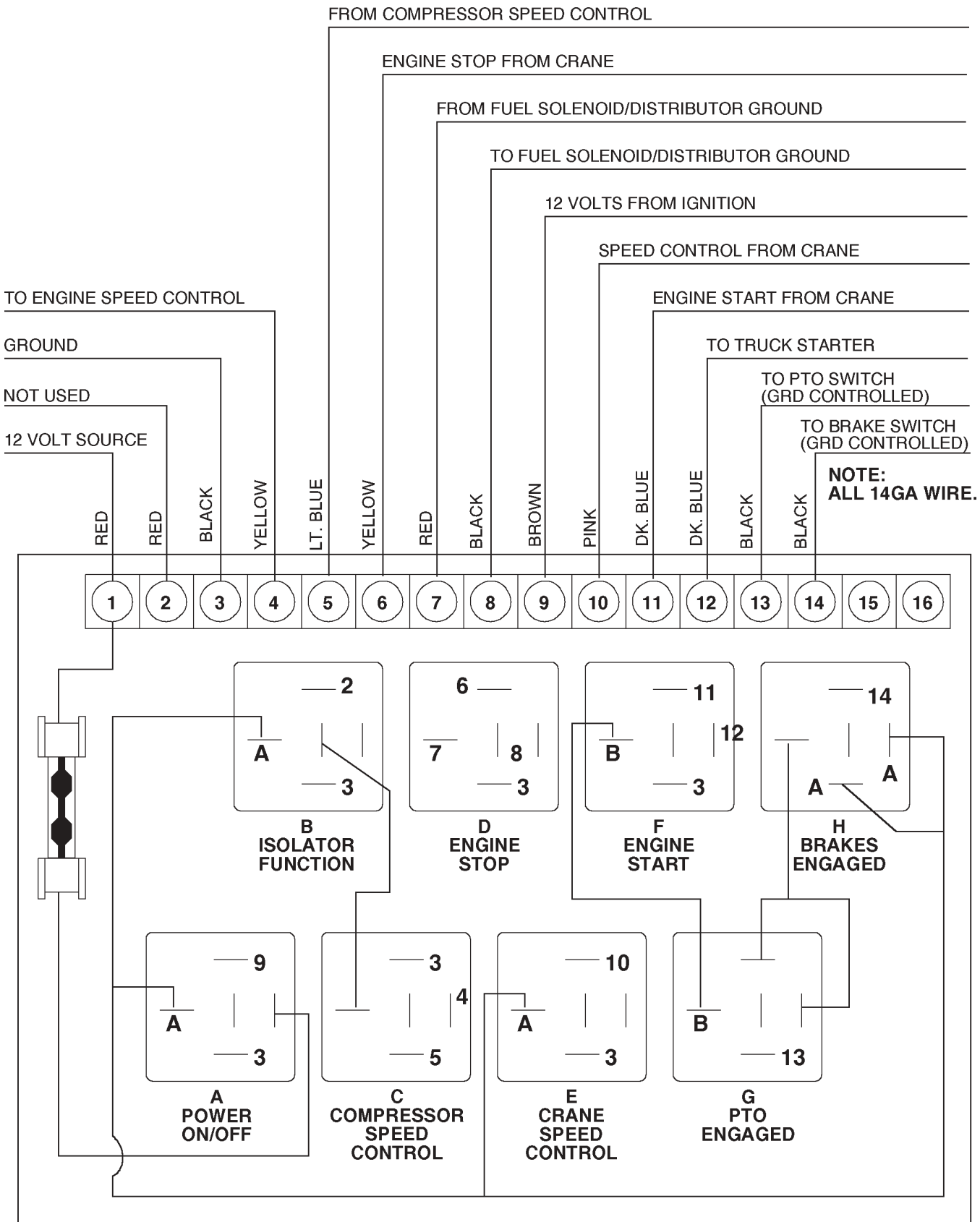

FIGURE 3. RELAY BOARD - COMPONENTS & WIRING

REMOTE ENGINE SPEED (FROM CRANE)

Engine speed can be controlled from the remote control handle. When the engine speed switch is activated, voltage is applied at terminal 10 of relay "E". The coil of relay "E" is energized and current is allowed to flow to the signal input of the speed control currently installed. The speed of the engine will remain higher as long as the engine speed switch in the remote control handle is allowed to remain in the same position. If this switch is returned to its original position, the engine speed control coil will be de-energized through relay "E".

Compressor operation will begin when the "Compressor-OFF-Crane" switch on the handset is toggled to the "Compressor" position. At that time, the power from the handset will provide power to the pressure switch on the compressor. When the pressure switch signals a need for more air pressure, the switch will trip and provide a signal to terminal 5 of the relay board.

Relay "C" energizes the coil in the relay, connecting terminal 4 to terminal "C" of the relay which is "HOT" from relay "B". Reference Figure 6 showing circuits energized (in bold) when engine speed is increased by the compressor. This will provide a "HOT" signal at terminal 4 which then provides a 12-volt signal to input of the speed control currently installed.

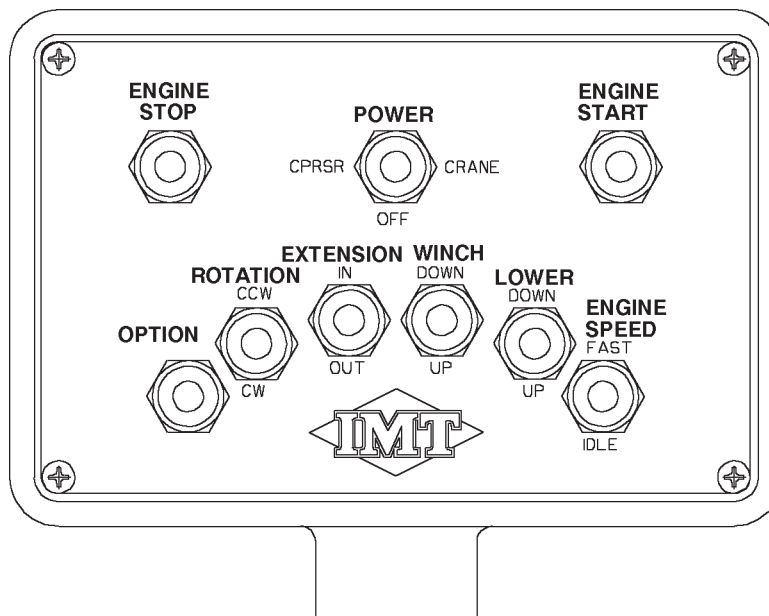

FIGURE 4. REMOTE CONTROL HANDLE

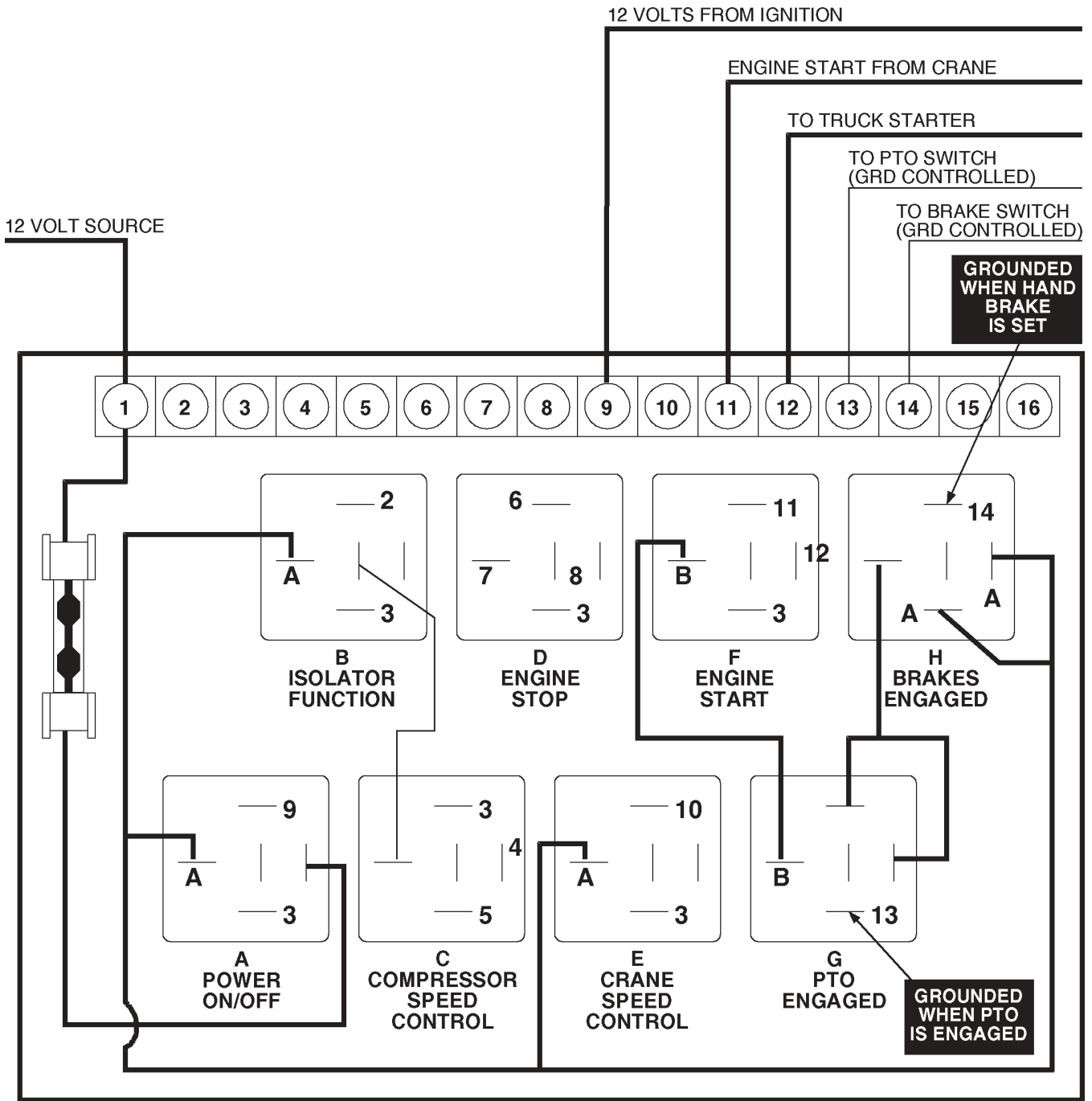

FIGURE 5. REMOTE STARTING OF VEHICLE - IGNITION "ON"

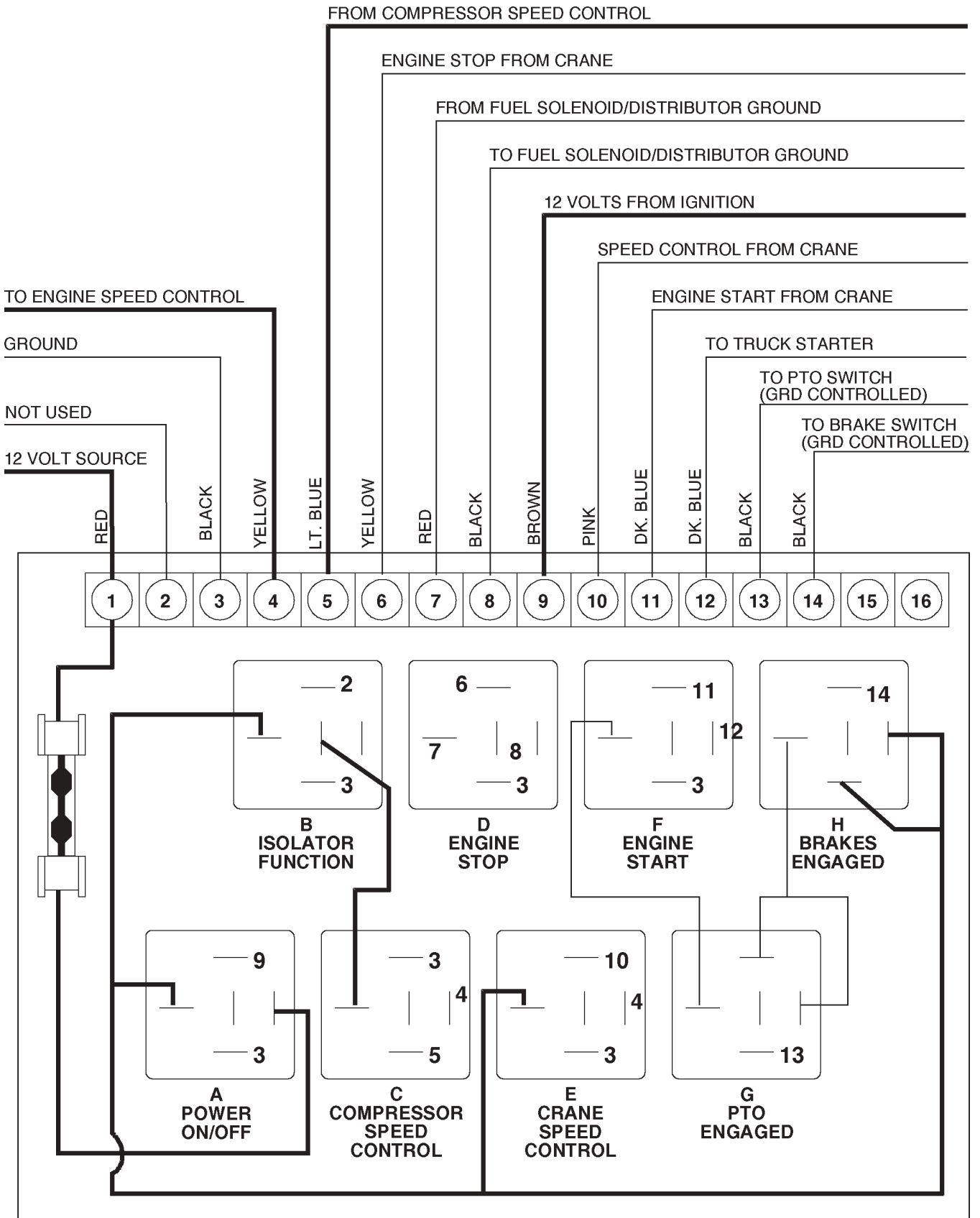

FIGURE 6. SPEED CONTROL - COMPRESSOR ONLY

INSTALLATION

1. Locate an area in the engine compartment that will both provide some protection against damage and accessibility for wiring.

2. Provide adequate space between the mounting surface and the back of the circuit board in order to prevent electrical contact. Failure to do so will cause erratic operation and/or circuit board failure.

3. Connect control wiring as indicated in Wiring Chart.

4. Jumper wires connections:

4-1. Jumper wires must connect J to K, and L to M for 12 volts excited systems. Remove the connecting wires between I to J and M to N.

4-2. Jumper wires must connect I to J, and M to N for ground excited systems*. Remove the connecting wires between J to K and L to M.

WARNING

Failure to remove the extra connecting wire will cause the relay board to fail. Check jumper wire connections of relay board being replaced. (Most relay boards are wired as stated in item 4-1.)

*** NOTES**

Circuits that could be ground excited are 6 - 10 & 11.
Quick Check: (Before connecting wires to circuit board)
Activate the engine stop switch from the crane. If terminal 6 is hot, wire per 4-1. If not, wire per 4-2.

WIRING CHART

TERM	WIRING CONNECTION
1	12-VOLT
2	NC
3	GROUND
4	TO SPEED CONTROL
5	SPEED CONTROL FROM COMPRESSOR
6	ENGINE STOP FROM CRANE
7	FROM FUEL SOLENOID / DISTRIBUTOR
8	GROUND
9	TO FUEL SOLENOID / DISTRIBUTOR
10	GROUND
11	12-VOLT FROM IGNITION
12	SPEED CONTROL FROM CRANE
13	ENGINE START FROM CRANE
14	TO TRUCK STARTER
15	TO PTO SWITCH, CONTROLLED
16	TO BRAKE SWITCH, CONTROLLED
15	NC
16	NC

RELAY FUNCTION

A	ON / OFF, POWER
B	ISOLATION, SPEED CONTROL
C	COMPRESSOR, SPEED CONTROL
D	ENGINE STOP
E	CRANE SPEED CONTROL
F	ENGINE START
G	PTO SWITCH
H	BRAKE SWITCH, CONTROLLED

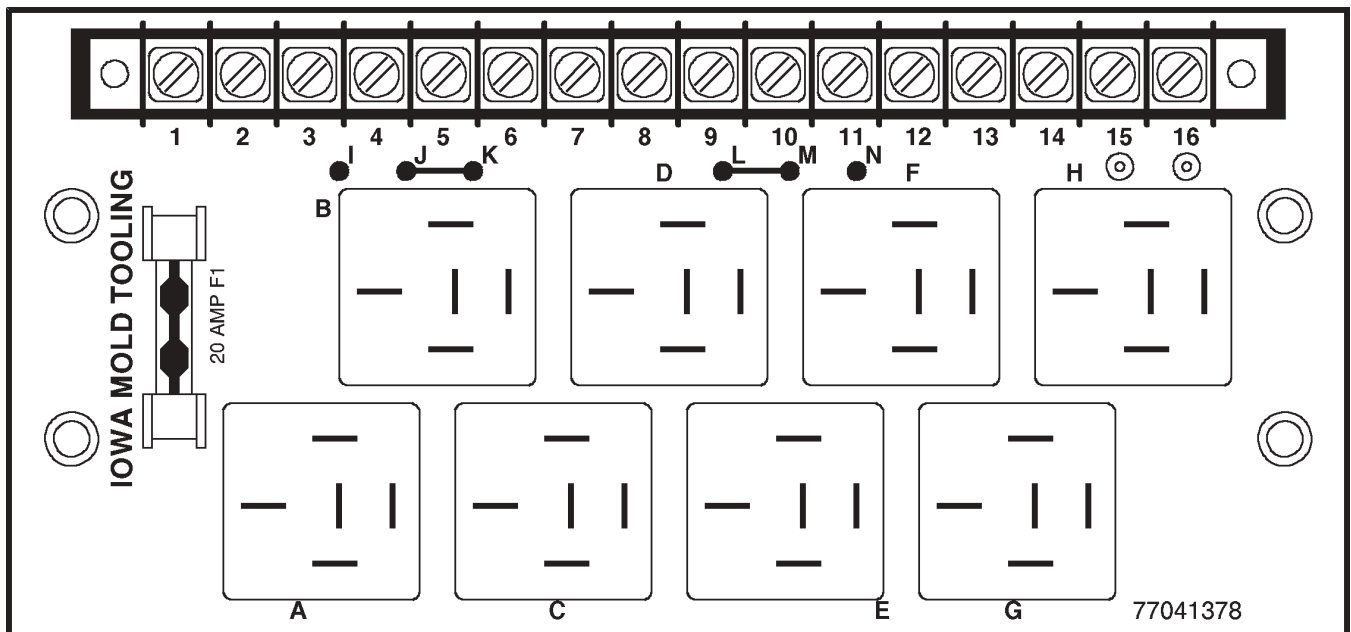

FIGURE 7. RELAY BOARD (77041378) WIRING INSTRUCTIONS

FLIP-UP BOOM SHEAVE

GENERAL

This section contains information regarding the operation of the Flip-up boom sheave which is an available option on the 6020 Crane. Refer to following figure for parts reference.

SINGLE-PART LINE OPERATION

To position the crane for single-line operation:

1. Disconnect the cable wedge socket (item 14) from the boom tip dead end link (item 51) by removing the other pin and keeper (items 53 and 35).
2. Remove the link by removing the other pin and keeper (items 53 and 35) and rotate the flip sheave weldment (item 52) to the horizontal position and insert one of the retaining pins and keepers (items 53 and 35) through the lower hole in the boom tip
3. Remove the two-part line snatch block (item 4) by removing the sheave (item 6) which is held in place by the pin (item 3), retainer plate (item 11) and wing bolt (item 50).
4. After the cable is freed from the snatch block, reassemble the sheave and snatch block. Store the snatch block assembly (items 3, 4 and 6) and the dead end link (item 51) in the chassis cab or a body compartment, if available.
5. Locate the 3-ton hook (item 55) which is stored separately on the chassis. Connect the hook to the cable wedge socket using the pin and keeper (items 53 and 35).

The crane should now be in position for single-part line operation. Note that no change in mounting of the anti two-blocking system is required.

TWO-PART LINE OPERATION

To position the crane for two-part line operation:

1. Disconnect the 3-ton hook (item 55) from the cable wedge socket (item 14) by removal of the pin and keeper (items 53 and 35). Store the hook in the chassis cab or a body compartment if available.
2. Locate the two-part line snatch block assembly (items 3, 4, 6 & 16) and cable dead end link (item 51) which are stored separately on the chassis.
3. Remove the pin and keeper (items 53 and 35) from the boom tip and rotate the flip sheave weldment (item 52) to the vertical position. Position the dead end link (item 51) in position with the sheave weldment (item 52) and insert the pin and keeper (items 53 and 35).
4. Disassemble the snatch block assembly (items 3, 4, 6 & 16) and string the cable through and reassemble the snatch block. Connect the cable wedge socket (item 14) to the dead end link (item 51) by using the other pin and keeper (items 53 and 35).

The crane should now be in position for two-part line operation. Note that no changes in mounting of the anti two-blocking system is required.

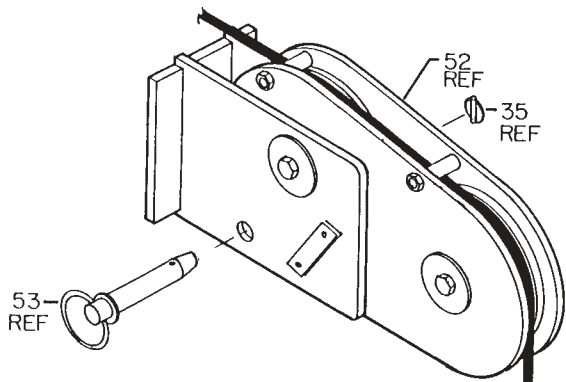

SINGLE-PART LINE OPERATION

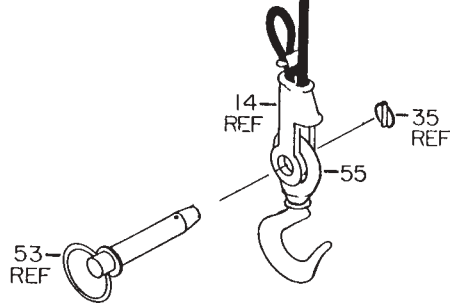

TWO-PART LINE OPERATION

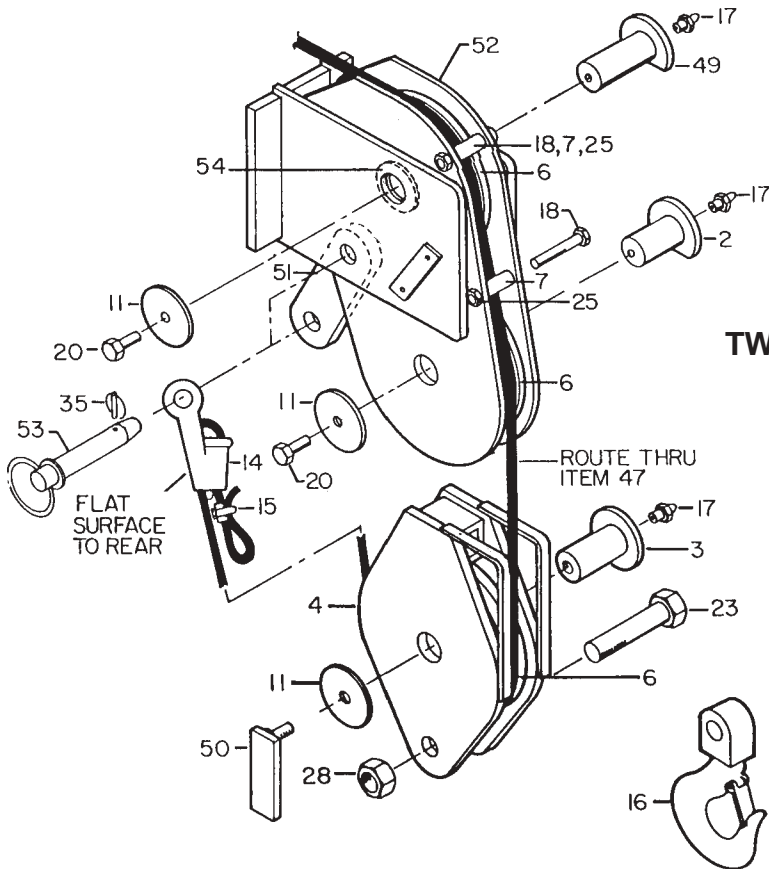

FLIP-UP BOOM SHEAVE OPTION

WINCH TROUBLESHOOTING

POSSIBLE CAUSE	PROBABLE CURE
WINCH WON'T LIFT HEAVY LOADS	
TOO MUCH LOAD	RIG TO REDUCE LOADING ON WINCH
LOW OR NO GEARBOX OIL	CHECK OIL LEVEL AND ADD PROPER OIL IF NECESSARY
MOTOR INLET PRESSURE LESS THAN SPECIFICATIONS WITH LOAD STALLED	TEST HYDRAULIC PUMP CHECK MAIN RELIEF - SHOULD BE 3000 PSI
MOTOR OUTLET PRESSURE TOO HIGH WITH LOAD STALLED	FIND AND REMOVE SOURCE OF RESTRICTION
BRAKE SHOULD ENGAGE IN PAYOUT DIRECTION ONLY	RUN WINCH WITH NO LOAD IN BOTH DIRECTIONS. SYSTEM PRESSURE SHOULD BE SLIGHTLY HIGHER IN PAYOUT DIRECTION.
CHECK FLOW TO WINCH MOTOR WITH WINCH UNDER LOAD	TEST PUMP IF NOT TO SPECIFICATIONS
CHECK END PLAY IN WORM	IF GREATER THAN 0.030", INSPECT WORM BEARINGS FOR WEAR. REPLACE IF NECESSARY.
WINCH WON'T HOLD LOAD	
BRAKE MAY NEED ADJUSTMENT	TURN ADJUSTING SCREW CLOCKWISE 1/4 TURN AT A TIME AND TEST WINCH AGAIN
BRAKE DISKS MAY BE WORN	INSPECT AND REPLACE IF NECESSARY. ADJUST AND RETEST
CAM CLUTCH IN BRAKE MAY BE INSTALLED INCORRECTLY	REVERSE CLUTCH AND RETEST
JOURNAL ON WORM WHERE CAM CLUTCH RUNS MAY BE GALLED OR WORN	INSPECT AND REPLACE WORM IF NECESSARY
WINCH RUNS TOO SLOW	
SYSTEM MAY HAVE LOW FLOW	INSTALL FLOW METER IN SYSTEM AND TEST UNDER LOAD. IF FLOW IS BELOW SPECIFICATIONS, INSPECT PUMP.
MOTOR WORN OUT	REPLACE MOTOR
WINCH WILL NOT RUN UNDER NO LOAD (RELIEF VALVE OPENS WITHOUT WINCH TURNING)	
MOTOR SEIZED UP	REMOVE MOTOR FROM WINCH AND TEST IF OPERABLE. IF NOT, REPLACE MOTOR.
WORM AND GEAR SET DAMAGED	REPAIR GEARBOX

See Section 3 for parts drawing.

ANTI TWO-BLOCKING DEVICE

IMT telescoping cranes using a winch are equipped with an Anti Two-Blocking Device which is designed to provide a method of sensing an approaching Two-Blocking situation and prevent the crane from entering that situation. It is the operator's responsibility to avoid Two-Blocking and not to rely on this device alone. The device must be checked daily for proper operation.

Keeping the system clean and the microswitch in operating condition, the system should function properly. The flexible rod should also be checked for unusual distortion.

NOTE

"Two-Blocking" is the condition in which the lower load block or hook assembly comes in contact with the upper load block or boom point sheave assembly.

Three means are available to relieve a two-blocking condition. The load may be lowered to the ground, the extension boom may be retracted, or the lower boom may be raised, thus reducing the reach of the crane.

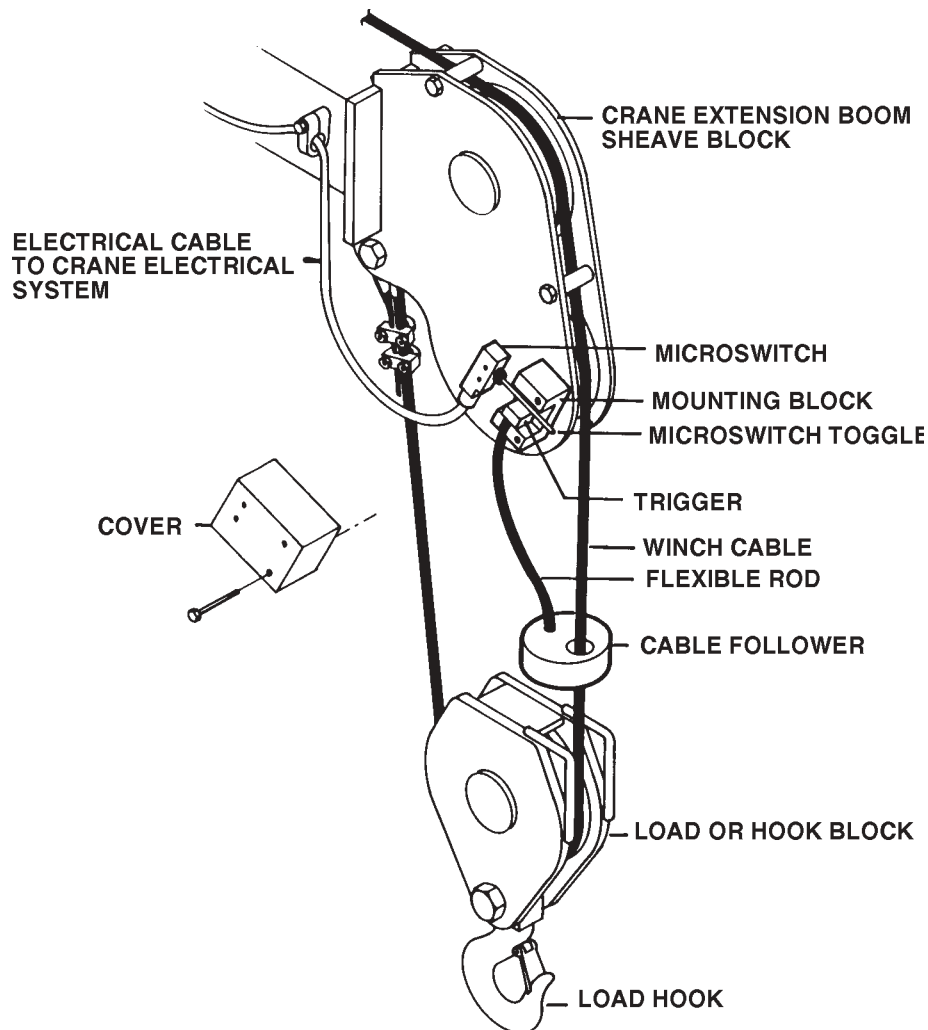

ANTI TWO-BLOCKING DEVICE COMPONENTS

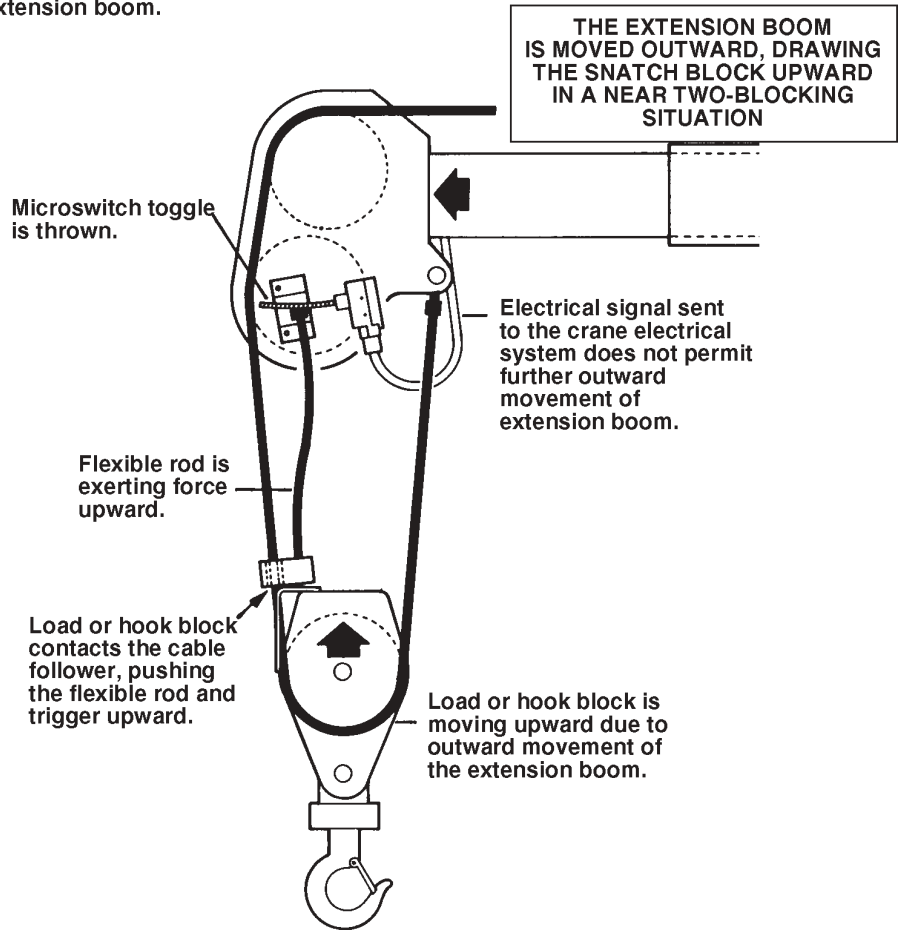
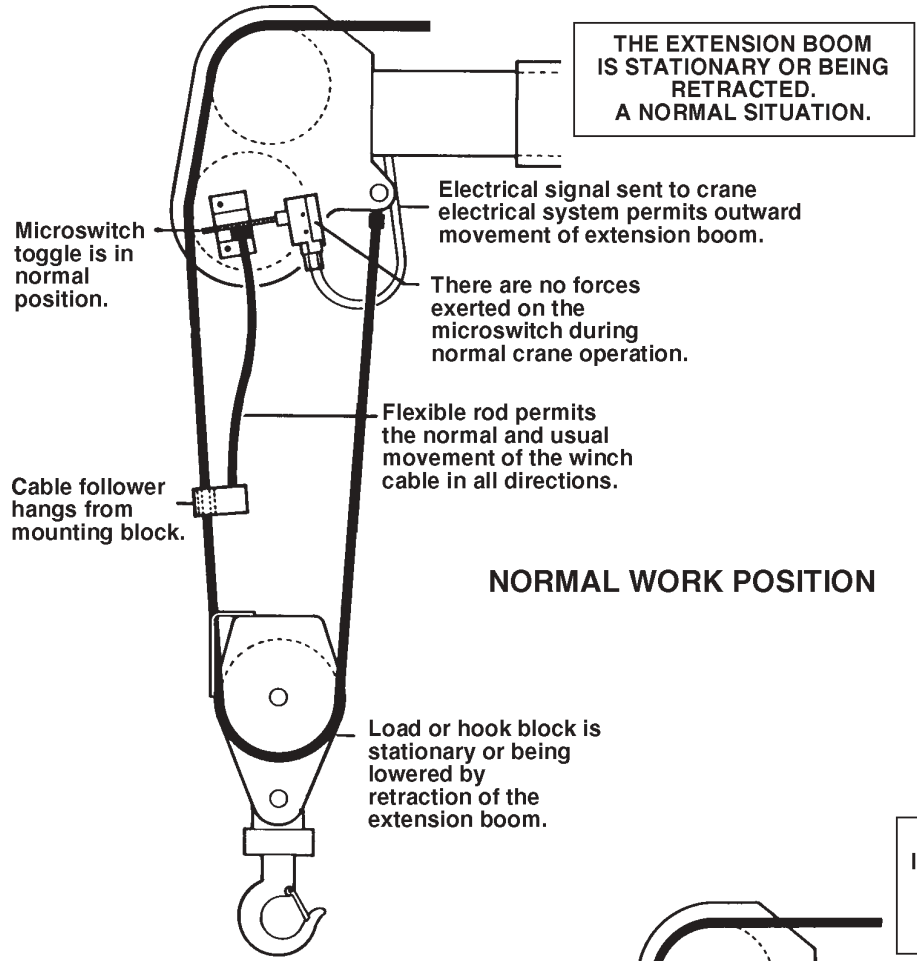

APPROACHING TWO-BLOCKING SITUATION

Excessive Load Limit System (ELLS) TEST PROCEDURE

This procedure is to be used for testing the Excessive Load Limit System (ELLS) used on the IMT Telescoping Crane models. Following this test procedure will ensure the system is currently operable and will not allow the crane to be excessively overloaded.

The purpose of the ELLS is to prohibit the excessive overloading of the crane. It does this by disarming the functions that make it possible for the operator to apply greater than allowable stress to the crane structure and components. The functions which are involved in the ELLS may vary for each crane model (Refer to TABLE 1 for which functions are shut down by the ELLS on each crane).

The load rating of the crane is determined by the pressure induced in the lower boom cylinder. The ELLS senses the pressure in the base end of the lower boom cylinder with a normally closed pressure switch located on the valve block on the top of the cylinder. When the pressure in the base end of the cylinder exceeds the setting of the pressure switch for that particular crane, the pressure switch opens and breaks the ground connection for the solenoids that shift the valve spool on the appropriate functions. Once the ground connection is disengaged, the solenoids that shift the valve spools for the appropriate functions can not be activated using the remote control handle. Only those functions that will not increase the load moment of the crane structure and components will be operable (i.e.- winch down, extension in, lower boom up, rotation). The operator is able to use "WINCH DOWN" to set the weight down to relieve the crane and "EXTENSION IN" to bring the load in for a shorter load radius. Either of these two functions will decrease the load moment of the crane structure and components, thus decreasing the pressure in the main cylinder.

ITEMS REQUIRED TO TEST THE CRANE ELLS (SEE PHOTOS NEXT PAGE)

PRESSURE GAGE ASSEMBLY (GAGE & PIPE-JIC ADAPTER)

-5000 PSI LIQUID FILLED PRESSURE GAGE W/ ¼" PIPE THRD		QTY 1
-1/4 PIPE-#6 JIC ADAPTER	(ref) PARKER PART# 0203-4-6	QTY 1

16" HOSE ASSEMBLY (¾" OR ¼" HOSE W/ #6 FEM. JIC FITTINGS & T-FITTING)

-TEE FITTING	(ref) PARKER PART# 653T-6-6	QTY 1
-#6 FJIC FITTING	(ref) PARKER PART# 10643-66	QTY 2
-3/8" SAE 100R16 HOSE	(ref) PARKER PART# 431-6	QTY 16"

4" HOSE ASSEMBLY (¾" OR ¼" HOSE W/ #6 FEM. JIC FITTINGS)

-#6 FJIC FITTING	(ref) PARKER PART# 10643-66	QTY 2
-3/8" SAE 100R16 HOSE	(ref) PARKER PART# 10643-66	QTY 4"

#6 STR-#6 MALE JIC FITTING

(ref) PARKER PART# 0503-6-6	QTY 2
-----------------------------	-------

#6
MALE
STRAIGHT
THREAD



#6
MALE
JIC

#6
MALE
STRAIGHT
THREAD



#6
MALE
JIC

TEE

ADAPTER

#6
MALE
JIC



1/4"
FEMALE
PIPE
THREAD



5000 PSI
LIQUID FILLED
PRESSURE GAUGE

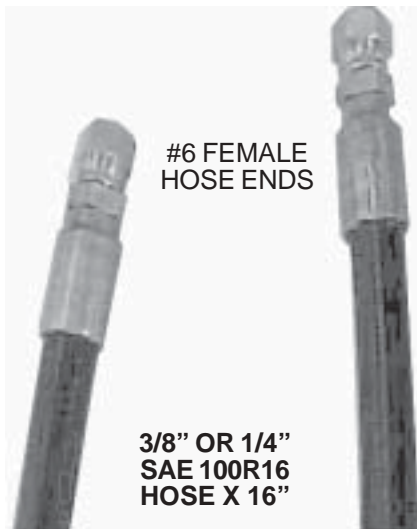

#6 FEMALE
HOSE ENDS

3/8" OR 1/4"
SAE 100R16
HOSE X 16"

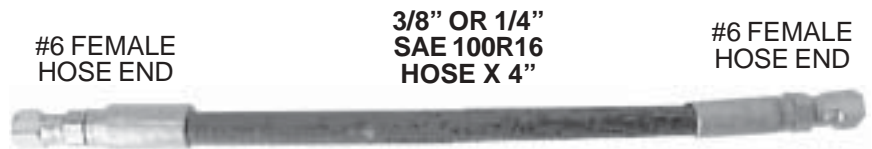

#6 FEMALE
HOSE END

3/8" OR 1/4"
SAE 100R16
HOSE X 4"

#6 FEMALE
HOSE END

TEST PROCEDURE

A. Position Crane Boom

1. Back the truck up to an immovable object to which the crane hook can be securely fastened. The boom tip must be directly over the immovable object when the crane is rotated to the rear of the truck, with the extension extended one foot.
2. Engage the parking brake and PTO.
3. Properly position all outriggers.
4. Rotate crane so it is pointing directly off the rear of the truck. (Most stable position)
5. Extend extension boom one foot.
6. Check to assure that the boom tip is positioned directly over the immovable object to which the crane hook can be securely attached.
7. Lower the lower boom until the lower boom cylinder is fully retracted and bottoms out.
8. After the boom is bottomed out, hold the "LOWER BOOM DOWN" function for two seconds to make sure cylinder is bottomed out.
9. Disengage PTO and turn off the engine in the truck.
10. Turn the truck ignition back on after the engine is stopped. **BE AWARE OF TRAPPED PRESSURE BEHIND THE PLUG IN THIS STEP!! PRESSURIZED OIL MAY CAUSE SERIOUS INJURY!!**
11. Trigger the function for the main boom up and down a few times to relieve trapped pressure in cylinder.

B. Attach Pressure Gauge (Procedure used depends on cylinder block used on crane.)

-Use Procedure 1 for cranes featuring a large valve block with a smaller block attached and the port tubes welded directly to the valve block and cylinder.

-Use Procedure 2 for cranes with only one valve block and the port tubes are removable by use of fittings on the valve block and on the cylinder.

1. **Procedure 1** (Large valve block with smaller block attached – port tubes welded)
 - a. BE AWARE OF TRAPPED PRESSURE BEHIND THE PLUG IN THIS STEP!! PRESSURIZED OIL MAY CAUSE SERIOUS INJURY!! Slowly remove #6 hex plug on the end of the smaller block on the lower boom cylinder.
 - b. Install #6 MJIC fitting into the port that the plug was removed from.
 - c. Attach 5000 PSI liquid-filled pressure gage assembly using 4” hose assembly.
 - d. Be sure to tighten all fittings securely.

PRESSURE GAGE ASSEMBLY & 4” HOSE ASSEMBLY

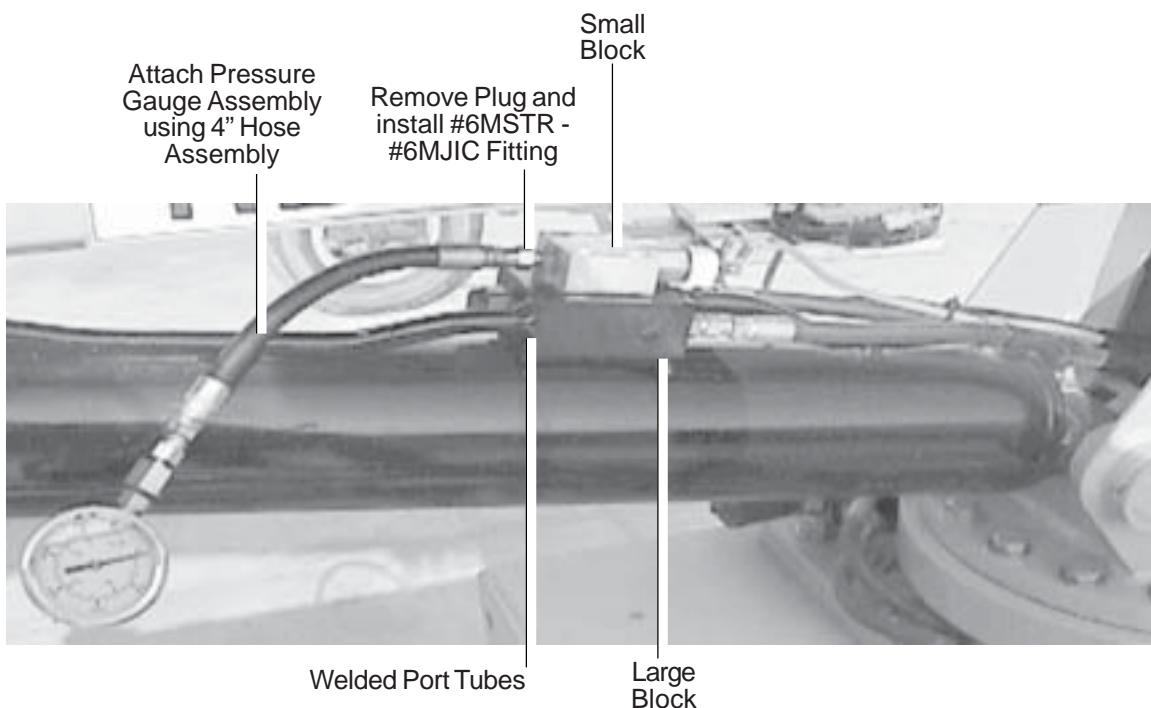

2. Procedure 2 (Large valve block only – port tubes removable)

- a. Remove bolts that attach the valve block to the cylinder
- b. BE AWARE OF TRAPPED PRESSURE BEHIND THE PLUG IN THIS STEP!! PRESSURIZED OIL MAY CAUSE SERIOUS INJURY!! Turn off fitting connecting port tube to base end of cylinder (end closest to crane base).
- c. Turn off fitting connecting port tube to valve block.
- d. Carefully remove port tube that runs from the valve block on the lower boom cylinder to the base end of the lower boom cylinder, being sure not to damage fittings.
- e. Remove fitting from valve block.
- f. Install 16" hose assembly with T-fitting (refer below) between block on lower boom cylinder and base end of lower boom cylinder.
- g. Attach pressure gage assembly to T-fitting using 4" hose assembly (refer to figure below).
- h. Be sure to tighten all fittings securely.

16" HOSE ASSEMBLY WITH T-FITTING & 4" HOSE ASSEMBLY

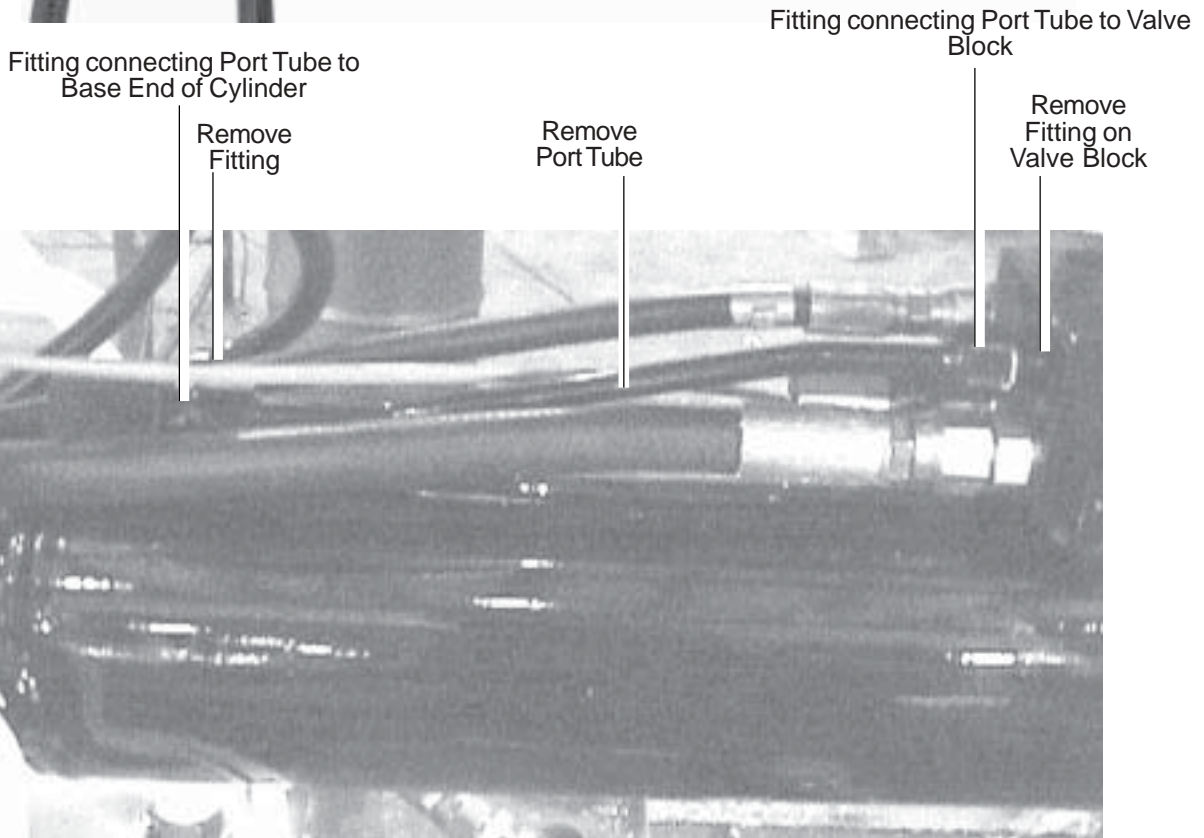

C. Test System

1. Start truck engine.
2. Raise boom up until boom cylinder is fully extended, then lower boom until cylinder is fully retracted to remove air that may have been introduced while installing the gage.
3. Raise boom to 15 degrees above horizontal and securely fasten crane hook to immovable object using a double line attachment.
4. Use the winch up function to take slack out of cable.
5. Refer to TABLE 1 for maximum pressure at which ELLS system should shut down appropriate functions for the particular crane model being tested.
6. While monitoring the pressure gage, use the winch up function to slowly apply down force on end of boom. If the pressure on the gage exceeds the maximum pressure for that particular crane and the ELLS has not shut down the appropriate functions, the ELLS is not working. Do not go any higher.
7. If the system is operating properly, the function should stop working before the gage reaches maximum pressure.
8. While the pressure gage still reads the pressure at which the ELLS shut down the appropriate functions, test the other functions that should be shut down by the ELLS (TABLE 1).
9. If the appropriate functions are not operational, the ELLS system is working
10. If any of the functions in Table 1 are still operational, the ELLS system is not working.
11. Refer to the TROUBLE SHOOTING PROCEDURE (page 6) for instructions to determine the problem with the ELLS.

TABLE 1

IMT CRANE MODEL	FUNCTIONS SHUT DOWN BY ELLS			MAX. TEST GAGE PRESSURE ALLOWED
	WINCH UP	EXTENSION OUT	LOWER DOWN	
1014	X	X	X*	2600
1014A	X	X	X	3000
2015	X	X	X*	3000
2020	X	X	X	3000
3016	X	X	X	3000
3020	X	X	X	3300
3816	X	X	X	3500
5016	X	X	X	3500
5020	X	X	X	3500
6016	X	X	X	3500
6020	X	X	X	3500
7020	X	X	X	3200
7025	X	X	X	3200
315A	X	X	N/A*	3200

* NOTE: Cranes before July 1996 do not have "LOWER BOOM DOWN" function tied into the Excessive Load Limit System.

ELLS TROUBLESHOOTING PROCEDURE

Each function (winch up, winch down, extension in, etc.) is actuated by a solenoid that shifts the valve spool to perform the particular function. The solenoids are located on the valve bank. Each solenoid has two wires protruding with a connector on the end that is plugged into a connector on the wire harness for the crane. There are two wires, one wire is black (ground) and the other wire is colored. The “ground receptacle” is the receptacle that the black wire connects to.

A. Find which solenoid actuates which function

-When a solenoid is actuated, it becomes magnetic. By using a piece of steel to find which solenoid is magnetic, (steel ruler, paper clip, etc.) the solenoids can be matched with which function it controls. It will not be a real strong magnetic pull, but will be detectable with a small piece of metal.

1. Be sure the truck ignition is on, the parking brake is engaged, and power is “on” to the crane. The PTO does not need to be engaged.
2. Activate “LOWER UP” on the remote control handle and use the piece of steel to find which solenoid is magnetic (being actuated).
3. When the correct solenoid is found, unplug the connector protruding from the solenoid.
4. Activate “WINCH UP” on the remote control handle and use the piece of steel to find which solenoid is magnetic (being actuated).
5. When the correct solenoid is found, unplug the connector protruding from the solenoid.
6. Unplug the connector protruding from the pressure switch (Some models may have wire terminals instead of a connection. Detach the wires from the pressure switch.)

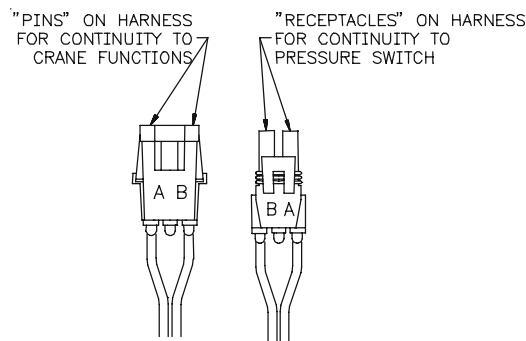

7. Using a multi-meter, check continuity (setting on multi-meter that “beeps” if two wires are connected) between the ground receptacle on the connector that plugs into the connector on the “LOWER UP” solenoid and the ground receptacle on the connector that plugs into the connector that plugs into the connector on the “WINCH UP” solenoid. They should not be continuous. If they are, the harness is the problem, which needs to be either repaired or replaced.
8. Reconnect the pressure switch.
9. Repeat steps 4-8 for each of the functions shut down by the ELLS. Instead of using “WINCH UP”, use the appropriate function and find the controlling solenoid and check for continuity with ground receptacle on the connector that plugs into the connector on the “LOWER UP” solenoid.
10. Activate “WINCH UP” on the remote control handle and use the piece of steel to find which solenoid is magnetic (being actuated).
11. When the correct solenoid is found, unplug the connector protruding from the solenoid.
12. Unplug the connector protruding from the pressure switch (Some models may have wire terminals instead of a connection. In this case, detach the wires and use the ground wire that attaches to the pressure switch for the next step.)
13. Using a multi-meter, check continuity between the ground receptacle on the connector that plugs into connector on the pressure switch and the ground receptacle on the connector that plugs into the connector on the “WINCH UP” solenoid. They should be continuous. If they are not, there is a problem with the harness, which either needs to be repaired or replaced.
14. Reconnect the pressure switch.
15. Repeat steps 10-14 for each of the functions shut down by the ELLS. Instead of using “WINCH UP”, use the appropriate function and find the corresponding solenoid. Each one should be continuous with the ground receptacle on the connector that plugs into the connector on the pressure switch.
16. If there is no problem found with the harness, the pressure switch is the problem and it will need to be replaced.

SECTION 3. MODEL 6020 REPLACEMENT PARTS

PARTS INFORMATION	3
BASE ASM (41715069)	4
GEAR ROTATOR (71056551)	5
MAST ASM (41715305)	6
LOWER BOOM ASM (41712180)	7
LOWER BOOM CYLINDER (3C126990)	8
EXT BOOM ASM (41707663)	9
EXT BOOM CYLINDER (3B309820)	10
LOCKING/HOLDING VALVE (73054900)	11
EXT BOOM W/ FLIP SHEAVE (41709440)	12
WINCH/CABLE/HOOK KIT (41712179)	13
WINCH/CABLE/HOOK KIT W/ FLIP SHEAVE (31712207)	14
WINCH (70570198)	15
CORD REEL ASM (51713168)	16
PROP'L RMT HANDLE ASM (51713182)	17
INSTALLATION KIT (93715067)	18
DECAL KIT (95715068)	19
OPTION-RESERVOIR (51709256)	20
OPTION-RESERVOIR 18 GAL-BULKHEAD (51707798)	21
OPTION-BOOM SUPPORT/RESERVOIR 20 GAL (51706910)	22
OPTION-BOOM SUPPORT (51708161)	23
OPTION-AUX OUTRIGGERS-PO/PD-7x5 (31712739)	24
OPTION-OUTRIGGER KIT-PO/PD-7x5 (31712731)	25
OPTION-AUX OUTRIGGERS-MO/PD-7x5 (31712740) (eff 9-03 - vb 51714813)	26
OPTION-AUX OUTRIGGERS-MO/PD-7x5 (31712740) (THRU 9-03 - VB 51705983)	27
OPTION-OUTRIGGER KIT-MO/PD-7x5 (31712732)	28
OPTION-AUX OUTRIGGERS-MO/CRANK DN-7x5 (31712741)	29
OPTION-OUTRIGGER KIT-MO/CRANK DN-7x5 (31718953)	30
OPTION-OUTRIGGER KIT-ELECTRIC PO/MD-7x5 (31712886)	31
OPTION-AUX OUTRIGGERS-MO/MD-7x5 (31712902)	32
CYLINDER-PWR DN (3B205010)	33
CYLINDER-PWR OUT (3B142860)	34
VALVEBANK ASM-2 SECTION (51705983)	35
VALVEBANK ASM-2 SECTION (51714813)	35
VALVEBANK ASM-3 SECTION OR - PO/PD (51714812)	36
VALVEBANK ASM-3 SECTION (51705984)	36
CONTROL KIT-RADIO RMT (90718833) (EFFECTIVE 8/04)	37
CONTROL KIT-RADIO RMT (90715635-1) (THROUGH 7/04)	38
CONTROL KIT-RADIO RMT (90715635-2) (THROUGH 7/04)	39
HANDLE ASM - RADIO REMOTE BACKUP (51716912) (EFF. 9/01)	40
HANDLE ASM-RADIO RMT (51715567) (THRU 9/01)	41
CABLE ASM-RADIO RMT BACKUP (73733374)	42
HYD KIT-RADIO RMT (91715633-1)	43
HYD KIT-RADIO RMT (91715633-2)	44
HYD KIT-RADIO RMT (91715633-3)	45
VALVEBANK-4 SECTION (73733383) (THROUGH 8-04)	46
VALVEBANK-4 SECTION (73733932) (EFFECTIVE 8-04)	47
WIRING HARNESS, RADIO REMOTE (77441101-1) (EFFECTIVE 8/04)	48
SCHEMATIC, RADIO REMOTE (77441101-2) (EFFECTIVE 8/04)	49
CIRCUIT CHART, RADIO REMOTE (77441101-3) (EFFECTIVE 8/04)	50
CABLE ASM, RADIO REMOTE (70733351-1) (THROUGH 7/04)	51
CABLE ASM (70733351-2) (THROUGH 7/04)	52
CABLE ASM (70733351-3) (THROUGH 7/04)	53
SCHEMATIC (99903131)	54

SECTION 3. MODEL 6020 REPLACEMENT PARTS, CONTINUED

COUNTERBALANCE VALVE (73540035)	55
HYD KIT (91715652-1)	56
HYD KIT (91715652-2)	57
HYD KIT (91715652-3)	58
VALVEBANK (73733396)	59
CABLE ASM (70733394-1)	60
CABLE ASM (70733394-2)	61
RADIO RMT KIT (70733354-1)	62
RADIO RMT KIT (70733354-2)	63
CHASSIS WIRING HARNESS (99903340)	64
WIRE ROUTING, PROP REMOTE CONTROL (90713879)	65
ELECTRICAL SCHEMATIC, PROP REMOTE CONTROL (99900855)	66

PARTS INFORMATION

GENERAL

This section contains the exploded parts drawings and accompanying parts lists for the assemblies used on this crane. These drawings are intended to be used in conjunction with the instructions found in the REPAIR section in Volume 1. For optional equipment, refer to the appropriate manual, or consult your IMT sales representative.

WARNING

DO NOT ATTEMPT TO REPAIR ANY COMPONENT WITHOUT READING THE INFORMATION CONTAINED IN THE REPAIR SECTION IN VOLUME 1. PAY PARTICULAR ATTENTION TO STATEMENTS MARKED WARNING, CAUTION, OR NOTE IN THAT SECTION. FAILURE TO COMPLY WITH THESE INSTRUCTIONS MAY RESULT IN DAMAGE TO THE EQUIPMENT, PERSONAL INJURY, OR DEATH.

CRANE IDENTIFICATION

Every IMT crane has an identification placard attached to the mast or to one of the booms in a prominent location. When ordering parts, communicating warranty information, or referring to the unit in correspondence, always include the serial number and model number. All inquiries should be directed to:

Iowa Mold Tooling Co., Inc.
 Box 189, Garner, IA 50438-0189
 Telephone: 641-923-3711
 Technical Support Fax: 641-923-2424

CYLINDER IDENTIFICATION

To insure that the proper cylinder replacement parts are received, it is necessary to specify the complete number/letter sequence for any part requested. Part numbers must be verified by checking the number stamped on the cylinder case (See figure below) against the information included in the service manual. You must include the part number stamped on the cylinder case when ordering parts.

WELDMENT IDENTIFICATION

Each of the major weldments, base, mast, lower boom, extension boom, and outriggers, have a part number stamped on them. Any time one of the weldments is to be replaced, it is necessary to specify the complete part number as stamped on that weldment. The location of the part numbers are shown Section 2.

ORDERING REPAIR PARTS

When ordering replacement parts it is important to follow the steps as outlined below.

1. Give the model number of the unit.
2. Give the serial number of the unit.
3. Specify the complete part number. When ordering cylinder parts, or one of the main weldments, always give the stamped part number.
4. Give a complete description of the part.
5. Specify the quantity required.

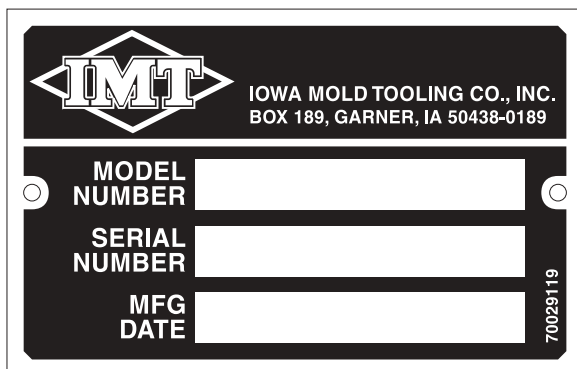

SERIAL NUMBER PLACARD

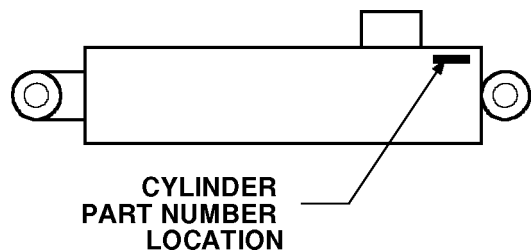

CYLINDER PART NUMBER LOCATION

BASE ASM (41715069)

ITEM	PART NO.	DESCRIPTION	QTY
1.	71056551	GEAR ROTATOR (INCL:11)	1
2.	73511070	HYD MOTOR (WAS 73051919)	1
3.	72060794	CAP SCR 1/2-13X1-1/4 SH	2
4.	60120192	GEAR GUARD	1
5.	60120138	SLIDE-ROT'N STOP	1
6.	70029595	PLUG 1-8	2
7.	51395121	HOSE-AA .13X13.5 #2#2	1REF
8.	72053301	COUPLING 1/8NPT BLK	1
9.	72053508	ZERK 1/8NPT	1
10.	70034382	GREASE CAP	3
11.	72533605	ZERK (PART OF 1)	2REF

NOTES

1. APPLY "MOLUB-ALLOY 936F" TO TURNTABLE BEARING AND WORM TEETH AT ASSEMBLY.
2. USE SERVICEABLE THREAD LOCKER.
3. APPLY THREE PUMPS OF EXTREME PRESSURE (EP2) GREASE TO WORM BEARINGS. ROTATE CRANE FULLY AFTER APPLICATION OF GREASE.

WARNING

Any time the gear-bearing bolts have been removed, they must be replaced with new bolts of identical grade and size. Failure to replace gear-bearing bolts may result in bolt failure due to metal fatigue causing serious injury or death.

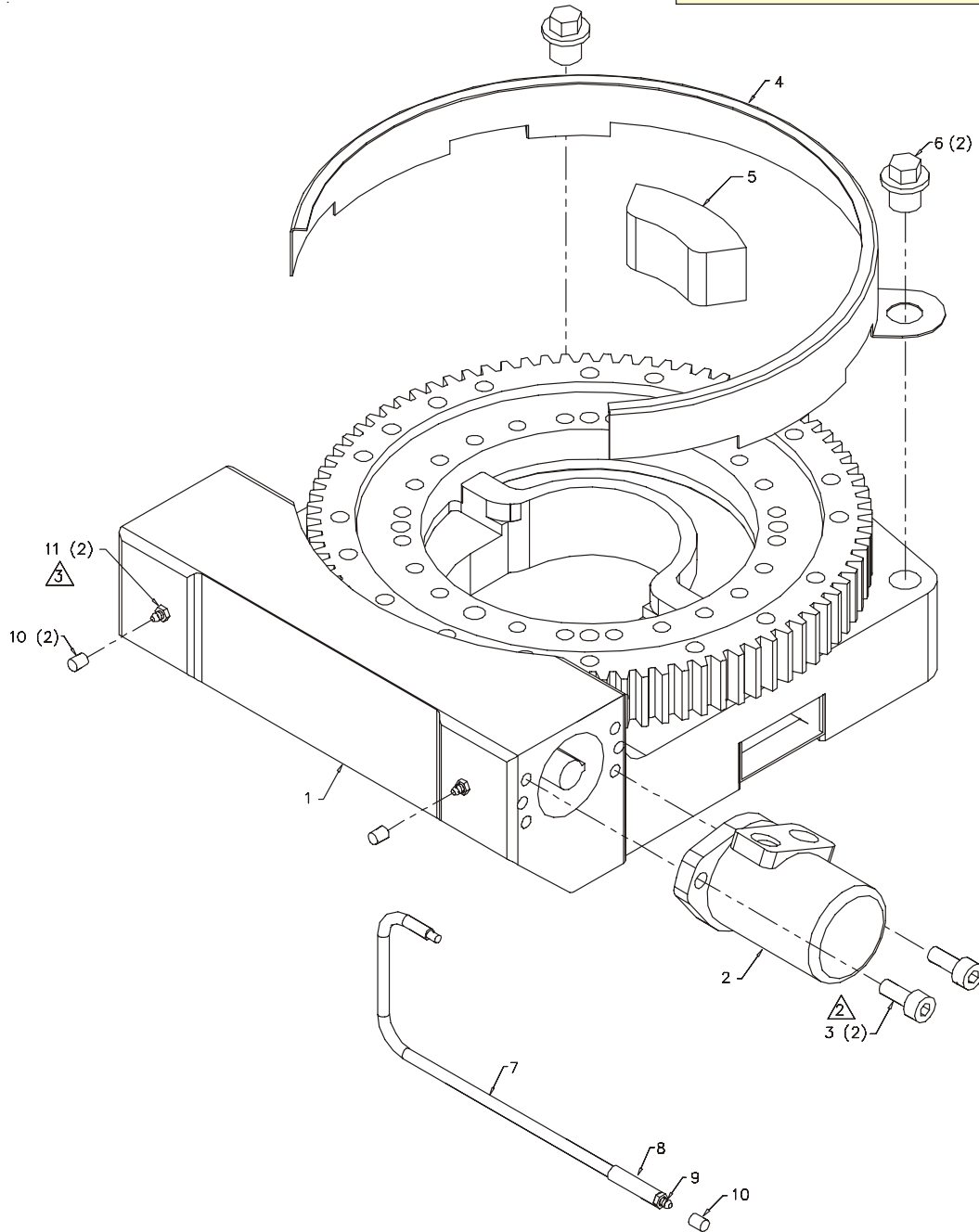

GEAR ROTATOR (71056551)

ITEM	PART NO.	DESCRIPTION	QTY
1.	70056552	SRB	1
2.	70395074	O-RING	1
3.	70395076	SEAL	2
4.	70145846	SNAP RING	1
5.	70055271	BEARING-CONE	2
6.	70055281	BEARING-CUP	2
7.	70145501	BEARING RETAINER	1
8.	70056550	WORM	1
9.	70145849	HOUSING	1
10.	70145847	LABLE PLATE	1
11.	70142375	DRIVE SCREW	2
12.	70145848	HOSE GUIDE	1
13.	72601754	SCR #10-24X3/8 SLTFH	4
14.	72601733	CAP SCR 1/2-13X1-1/4 FERRY1	4
15.	73145506	SHIM-.005	2
16.	73145505	SHIM-.015	2
17.	73145504	SHIM-.030	2
18.	76039295	GASKET	1
19.	72533604	PLUG	1
20.	72661504	DOWEL PIN 3/8X1	2
21.	72601751	CAP SCR 5/8-11X2-3/4 HHGR8	23
22.	72063219	WASHER 5/8 HARD	23
23.	72533605	ZERK	2

ASSEMBLY NOTES

- INSTALL SEALS 3 & 19 USING LOCTITE PLASTIC GASKET (54931) ON O.D. LUBRICATE SEAL SURFACE BEFORE ASSEMBLY.
- PACK CAVITIES WITH EPO GREASE.
- SHIM TO OBTAIN .000-.004 END PLAY ON WORM SHAFT.
- LUBRICATE O-RING 2 WITH WORM GEAR OIL BEFORE INSTALLING.
- SET BACKLASH BETWEEN WORM & ROTATION BEARING AT .005-.012".
- TIGHTEN 5/8-11, GR8 MOUNTING BOLTS AS FOLLOWS:
 - TIGHTENING MUST BE PROGRESSIVE AND AT 180° INTERVALS.
FIRST INTERVAL IS AT 70 FT-LBS.
SECOND INTERVAL IS AT 140 FT-LBS.
THIRD INTERVAL IS AT 210 FT-LBS.
 - TIGHTEN BOLTS IN ORDER AS SHOWN IN DIAMONDS.
 - DO NOT USE LOCTITE ON MOUNTING BOLTS.
- ITEM 23 SHIPS LOOSE.

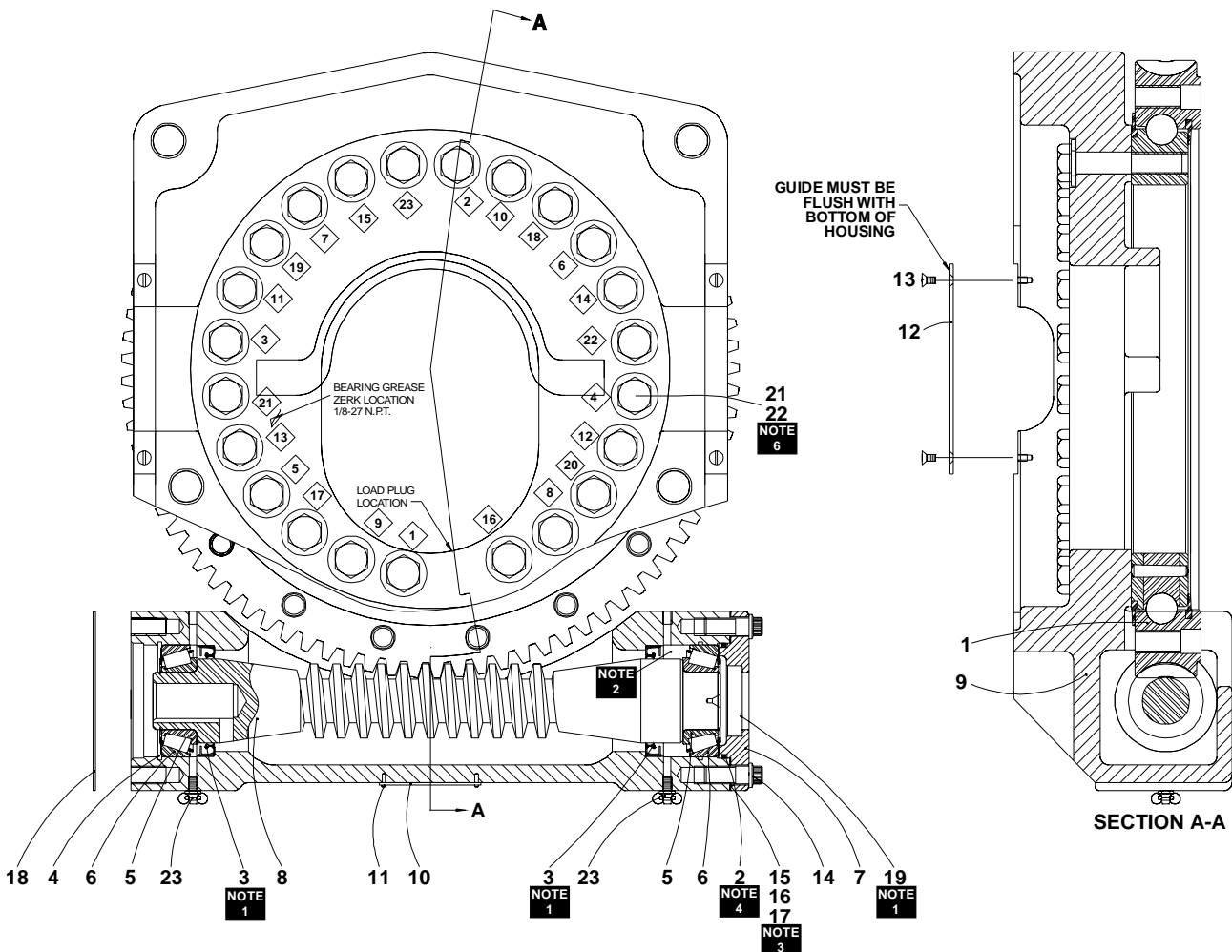

MAST ASM (41715305)

ITEM	PART NO.	DESCRIPTION	QTY
1.	52715304	MAST	1
2.	60119127	COVER-VB	1
3.	72601482	CAP SCR 5/8-11X2-1/2 HHGR8	18
4.	72063119	WASHER 5/8 FLAT HARD	18
5.	72060004	CAP SCR 1/4-20X1 HHGR5	4
6.	72063001	WASHER 1/4 WRT	8
7.	72062104	NUT 1/4-20 HEX LOCK	4
8.	70029119	SERIAL NO. PLACARD	1
9.	72066340	RIVET 1/8X3/8GRIP POP	2

WARNING

Anytime the gear-bearing bolts have been removed, they must be replaced with new bolts of identical grade and size. Failure to replace gear-bearing bolts may result in bolt failure due to metal fatigue, causing serious injury or death.

Note: Do not use thread lock on item #3.

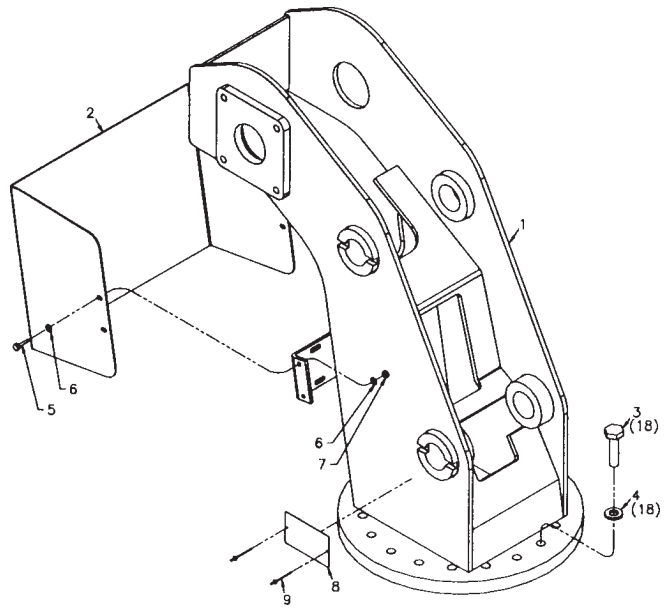

LOWER BOOM ASM (41712180)

1.	3C126990	CYLINDER (INCL. 20)	1
2.	52703748	PIN	1
3.	52703747	PIN	2
4.	52712159	LOWER BOOM (INCL: 5)	1
5.	7BF81520	BUSHING (PART OF 4)	4REF
6.	60030015	WEAR PAD	2
7.	60030139	WEAR PAD	1
8.	60103463	RETAINER PLATE	2
9.	60105544	ANGLE INDICATOR	2
10.	60106331	PIN RETAINER PLATE-3-1/2"	3
11.	72053508	GREASE ZERK 1/8 NPT	1
12.	72060023	CAP SCR 5/16-18X3/4 HHGR5	8
13.	72060147	CAP SCR 5/8-11X1 HHGR5	3
14.	72062103	NUT 3/8-16 LOCK	2
15.	72063003	WASHER 3/8 WRT	2
16.	72063005	WASHER 1/2 WRT	4
17.	72062104	NUT 1/4-20 LOCK	2
18.	72063050	WASHER 5/16 LOCK	8
19.	72601043	CAP SCR 3/8-16X3/4 FLH SOC	2
20.	72053507	GREASE ZERK 1/4-28 (PART 1)	2REF
21.	70034381	CORD GUIDE	2

NOTE

Any time the pin retainer plate bolts have been removed, apply serviceable thread locker to the threads before reassembly.

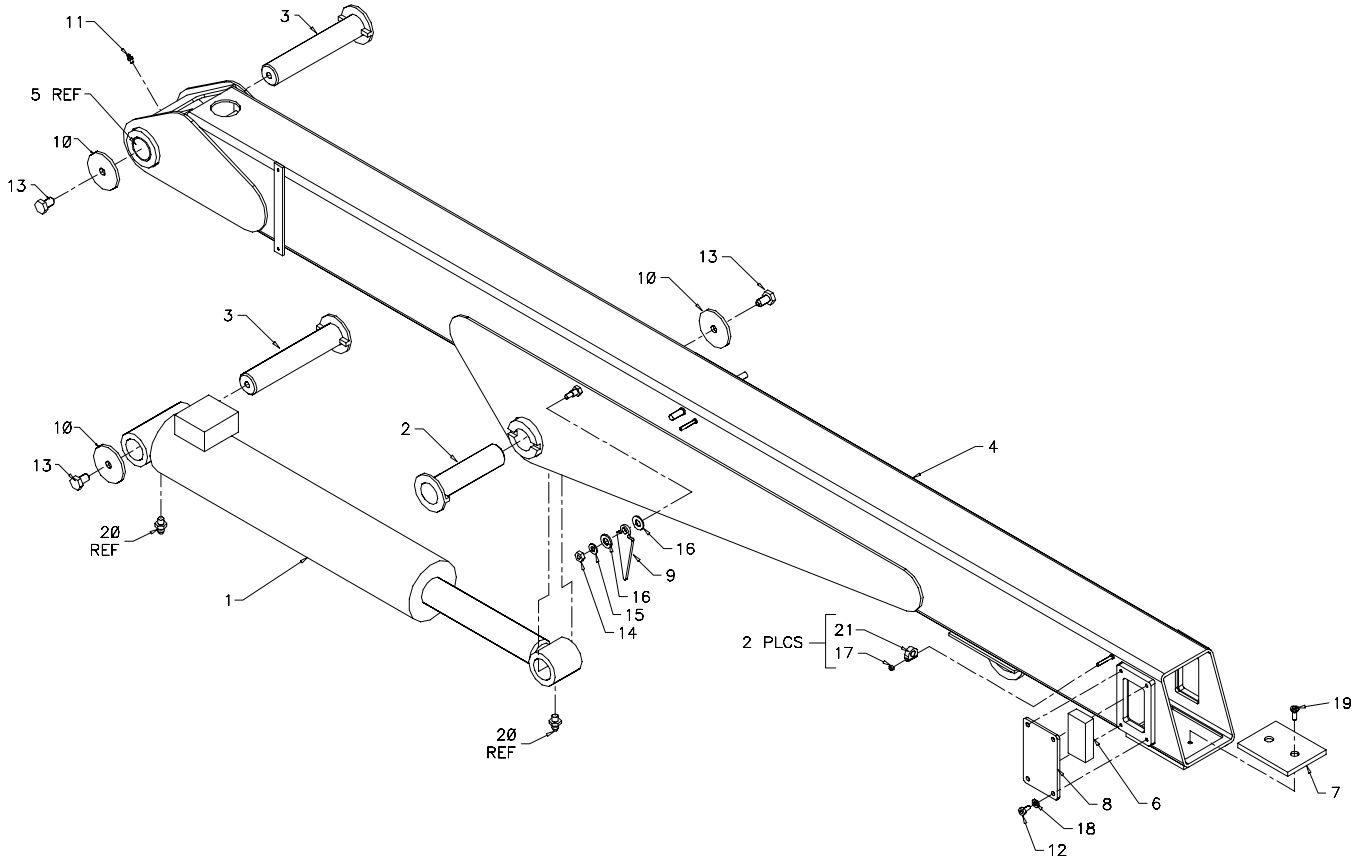

LOWER BOOM CYLINDER (3C126990)

1.	4C126990	CASE ASM (INCL: 3,4,20)	1REF
2.	4G038940	ROD ASM (INCL: 3,20)	1REF
3.	7BF81520	BUSHING (PART OF 1 & 2)	6REF
4.	72533186	ADAPTER #6MFACE #6MSTR	4
6.	6I503181	PISTON	1REF
7.	6H050025	HEAD	1REF
8.	9B043920	SEAL KIT (INCL: 9-17)	1REF
9.	7Q072350	O-RING (PART OF 8)	1REF
10.	7Q10P350	BACKUP RING (PART OF 8)	1REF
11.	7T2N8027	WEAR RING (PART OF 8)	1REF
12.	7R546025	U-CUP (PART OF 8)	1REF
13.	7R14P025	ROD WIPER (PART OF 8)	1REF
14.	7T61N181	LOCK RING (PART OF 8)	1REF
15.	7T66P500	PISTON SEAL (PART OF 8)	1REF
16.	7T2N4050	WEAR RING (PART OF 8)	2REF
17.	6A025025	WAFER LOCK (PART OF 8)	1REF
18.	6C150025	STOP TUBE	1REF
19.	6C075025	STOP TUBE	1REF
20.	72053507	GREASE ZERK (PART OF 1 & 2)	2REF
21.	73540035	C'BAL VALVE (INCL:22,27)	1REF
22.	73540052	C'BAL VALVE (PART OF 21)	1REF
	73540039	C'BAL VALVE BEFORE 2-15-00	1REF
23.	72060037	CAP SCR 5/16-18X4 HHGR5	2
24.	72063002	WASHER 5/16 WRT	4
25.	72062109	NUT 5/16-18 LOCK	2
26.	70145927	TUBE ASM	1
27.	77041561	PR. SWITCH (PART OF 21)	1REF
28.	70145753	TUBE ASM	1
29.	3C126990	CYLINDER	1

NOTE

IT IS RECOMMENDED THAT ALL COMPONENTS OF THE SEAL KIT BE REPLACED WHENEVER THE CYLINDER IS DISASSEMBLED. THIS WILL REDUCE FUTURE DOWNTIME.

APPLY "LUBRIPLATE #630-2" MEDIUM HEAVY, MULTI-PURPOSE LUBRICANT OR EQUIVALENT TO ALL PISTON, HEAD GLAND, AND HOLDING VALVE SEALS, NYLON LOCK RING, CAST IRON PISTON RINGS, AND ROD STINGER THREADS.

APPLY "NEVER-SEEZ" REGULAR GRADE ANTI-SEIZE AND LUBRICATING COMPOUND TO CYLINDER HEAD AND CASE THREADS.

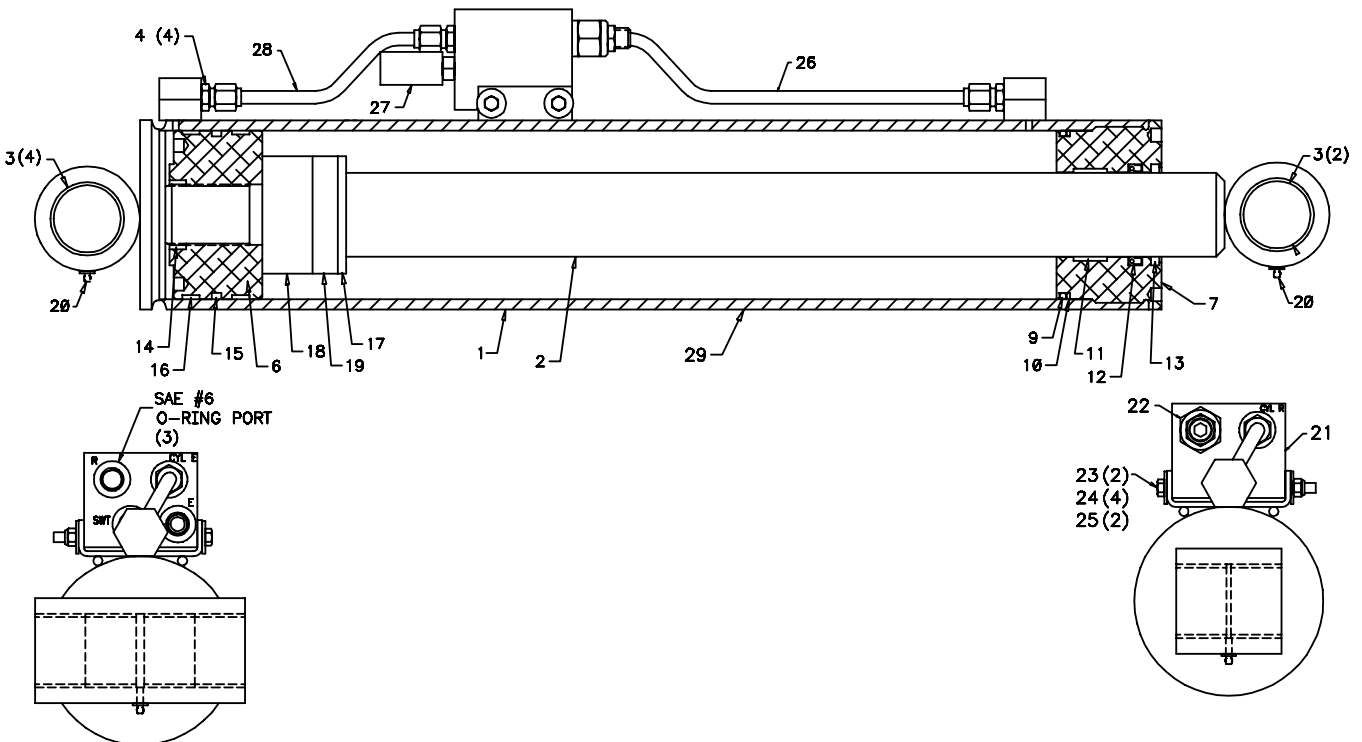

00006020: 41707663.01.19990104

3-9

EXT BOOM ASM (41707663)

ITEM	PART NO.	DESCRIPTION	QTY
1.	3B309820	EXTENSION CYLINDER	1
2.	73733171	PIN 1X6 LOCK W/HAIRPIN	1
3.	52707723	1ST STAGE EXT BOOM	1
4.	52707724	2ND STAGE EXT BOOM	1
5.	60030189	WEAR PAD	1
6.	60101905	PIN	1
7.	60121447	STROKE STOP	1
8.	72060092	CAP SCR 1/2-13X1-1/4 HHGR5	4
9.	72063034	MACH BUSHING 1X10GA	1
10.	72063053	WASHER 1/2 LOCK	4
11.	72066125	RETAINING RING 1 HD EXT	1
12.	72066145	HAIR PIN .19	1
13.	72601750	CAP SCR 3/8-16X1/2BHDSOC	2
14.	70034381	CORD GUIDE	2
15.	72060006	CAP SCR 1/4-20X1-1/2 HHGR5	2
16.	72063049	WASHER 1/4 LOCK	2

NOTE

CORD GUIDE (70034381) SHOULD BE INSTALLED WITH GUIDE HOLE UP.

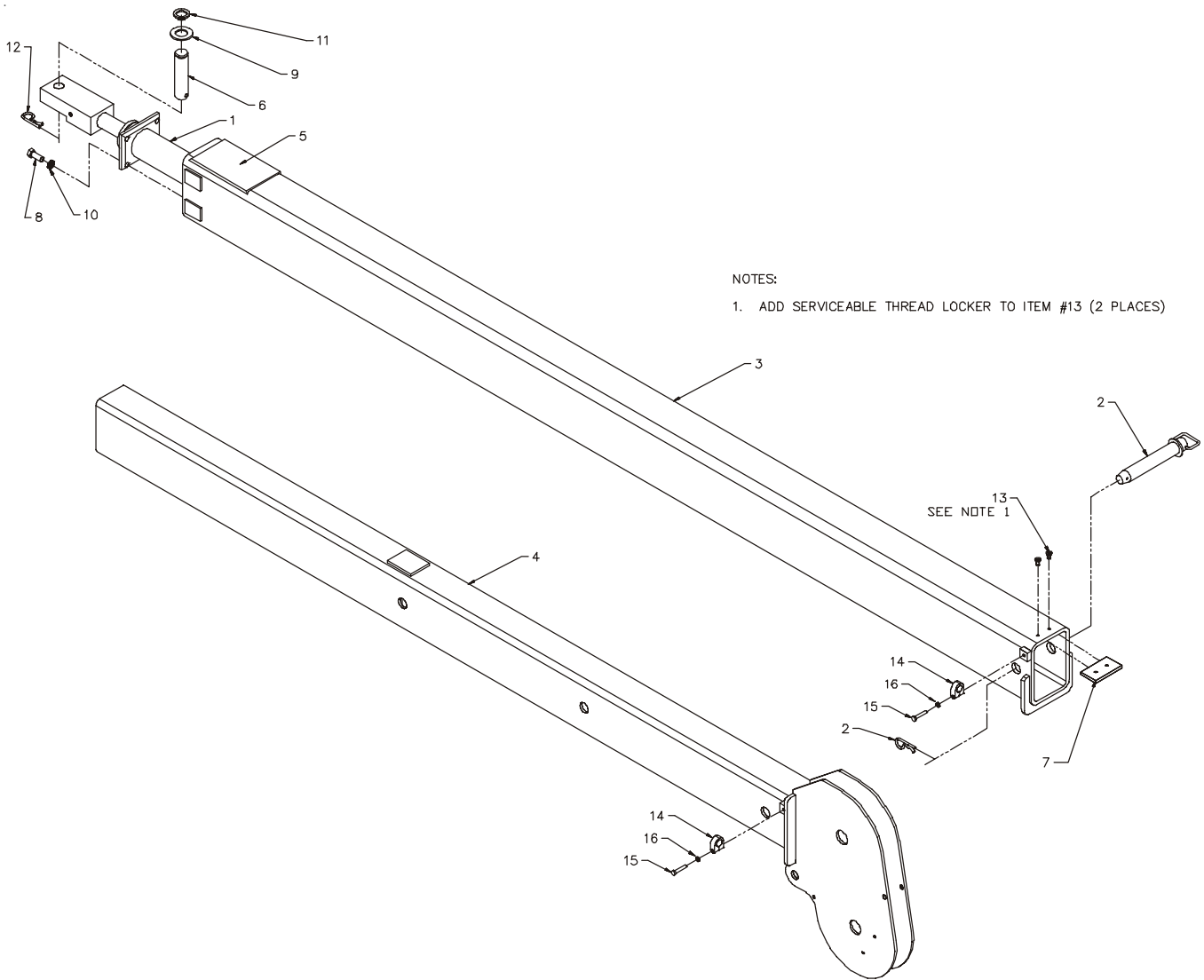

EXT BOOM CYLINDER (3B309820)

NOTE

ITEM	PART NO.	DESCRIPTION	QTY
1.	4B309820	CASE (INCL:3)	1
2.	4H309820	ROD (INCL:)	1
3.	7PNPXT02	PLUG (PART OF 1)	3REF
4.	6H025015	HEAD	1
5.	6IX02512	PISTON	1
6.	6C300015	STOP TUBE	1
7.	6C309820	STOP TUBE	1
8.	72060713	CAP SCR 1/4-20X2-1/2 SH	6
9.	73054900	HOLDING VALVE	1
10.	9B101220	SEAL KIT (INCL: 11-19)	1
11.	7T61N125	LOCK RING SEAL (PART OF 10)	1REF
12.	7T66P025	PISTON SEAL (PART OF 10)	1REF
13.	7Q072137	O-RING (PART OF 10)	1REF
14.	6A025015	WAFER LOCK RING(PART OF10)	1REF
15.	7Q072228	O-RING (PART OF 10)	1REF
16.	7Q10P228	BACK-UP RING (PART OF 10)	1REF
17.	7R546015	ROD SEAL (PART OF 10)	1REF
18.	7R14P015	ROD WIPER (PART OF 10)	1REF
19.	7T2N8015	WEAR RING (PART OF 10)	1REF

IT IS RECOMMENDED THAT ALL COMPONENTS OF THE SEAL KIT BE REPLACED WHENEVER THE CYLINDER IS DISASSEMBLED. THIS WILL REDUCE FUTURE DOWNTIME.

APPLY "LUBRIPLATE #630-2" MEDIUM HEAVY, MULTI-PURPOSE LUBRICANT OR EQUIVALENT TO ALL PISTON, HEAD GLAND, AND HOLDING VALVE SEALS, NYLON LOCK RING, CAST IRON PISTON RINGS, AND ROD STINGER THREADS.

APPLY "NEVER-SEEZ" REGULAR GRADE ANTI-SEIZE AND LUBRICATING COMPOUND TO CYLINDER HEAD AND CASE THREADS.

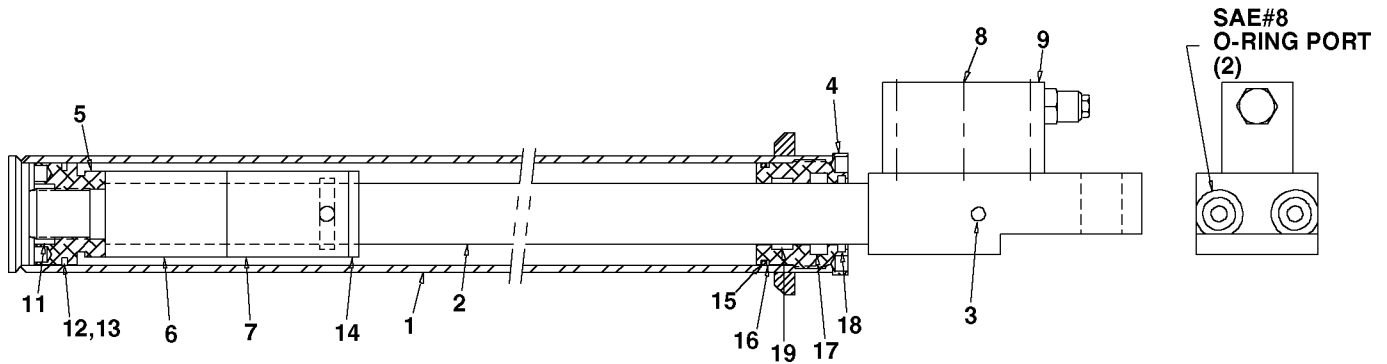

LOCKING/HOLDING VALVE (73054900)

ITEM	PART NO.	DESCRIPTION	QTY
1.	5V245940	VALVE BODY	1
2.	73054999	COUNTERBALANCE VALVE	1
3.	7Q072112	O-RING	3

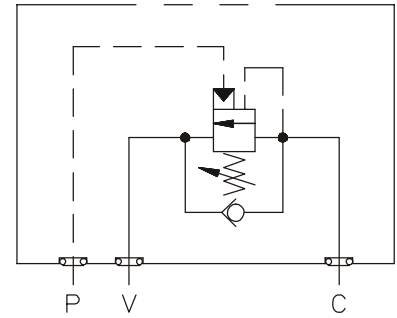
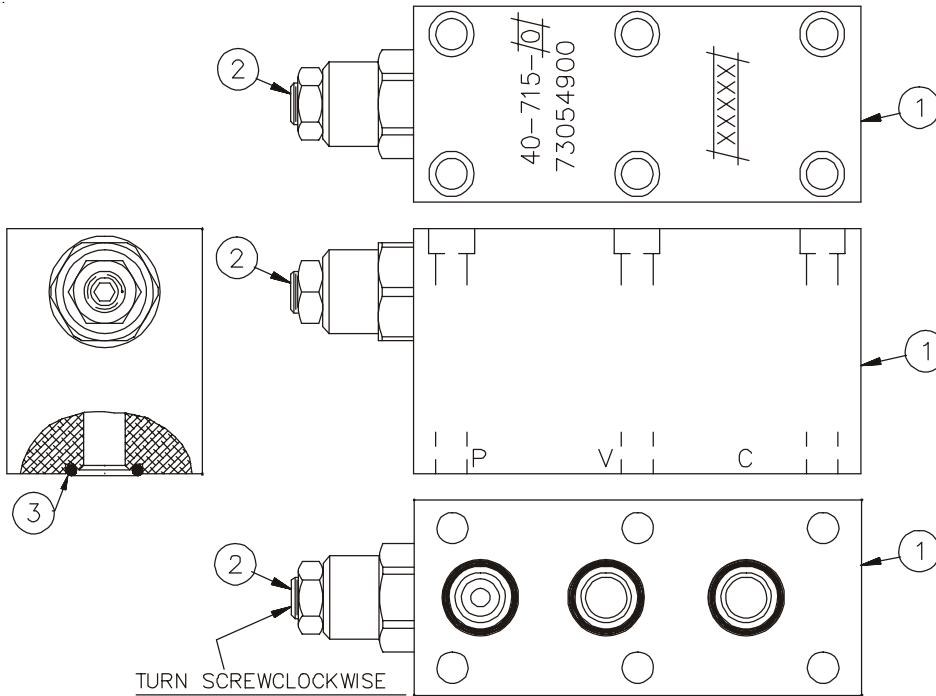

SYMBOL

INSTALLATION TORQUE
FOR ITEM 2
TO BE 30-35 FT.LBS.

TURN SCREWCLOCKWISE
TO REDUCE SETTING
AND RELEASE LOAD

EXT BOOM W/ FLIP SHEAVE (41709440)

NOTE

CORD GUIDE (70034381) SHOULD BE INSTALLED WITH GUIDE HOLE UP.

ITEM	PART NO.	DESCRIPTION	QTY
1.	3B309820	EXTENSION CYLINDER	1
2.	73733171	PIN 1X6 LOCK W/HAIRPIN	1
3.	52707723	1ST STAGE EXT BOOM	1
4.	52709456	2ND STAGE EXT BOOM	1
5.	60030189	WEAR PAD	1
6.	60101905	PIN	1
7.	60121447	STROKE STOP	1
8.	72060092	CAP SCR 1/2-13X1-1/4 HHGR5	4
9.	72063034	MACH BUSHING 1 X 10GA	1
10.	72063053	WASHER 1/2 LOCK	4
11.	72066125	RETAINING RING 1 HD EXT	1
12.	72066145	HAIR PIN .19	1
13.	72601750	CAP SCR 3/8-16X1/2 BHDSOC	2
14.	70034381	CORD GUIDE	2
15.	72060006	CAP SCR 1/4-20X1-1/2 HHGR5	2
16.	72063049	WASHER 1/4 LOCK	2

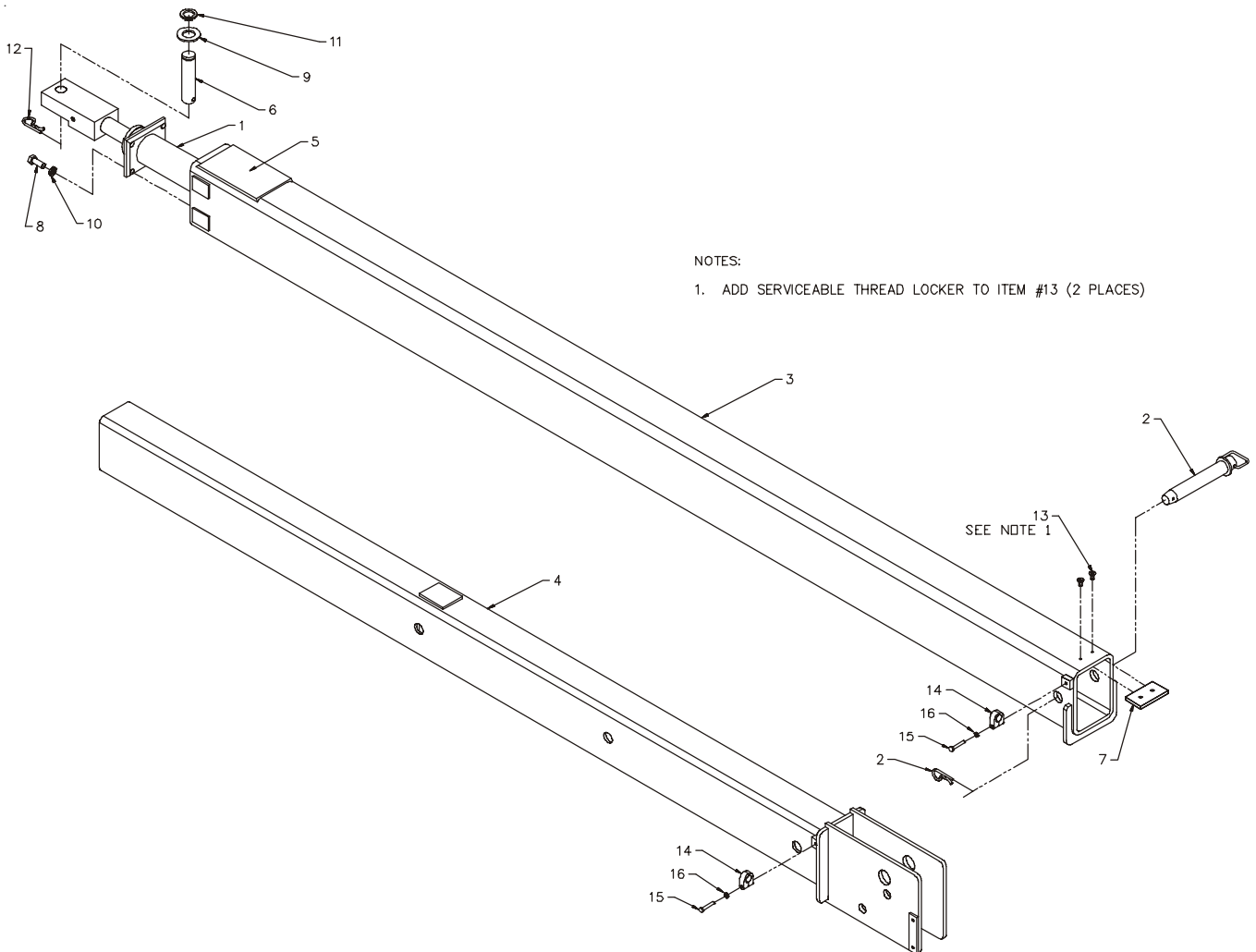

NOTES:

1. ADD SERVICEABLE THREAD LOCKER TO ITEM #13 (2 PLACES)

WINCH/CABLE/HOOK KIT (41712179)

ITEM	PART NO.	DESCRIPTION	QTY
1.	52712162	WINCH DRUM	1
2.	52707730	PIN	2
3.	52707731	PIN	1
4.	52707735	SNATCH BLOCK	1
5.	60030108	ROLLER - CABLE GUIDE	1
6.	60030255	SHEAVE	3
7.	60102596	SPACER	2
8.	60105538	STUD- CABLE GUIDE	1
9.	60105540	CABLE GUIDE SIDE BAR	2
10.	70580089	CABLE 7/16 x 100' IWRC-XIP	1
11.	60109337	PIN RETAINER PLATE 3"	3
12.	70055117	BEARING, FLANGE	1
13.	70570198	WINCH	1
16.	70732882	HOOK-SWVL POS LOCK 5.9TON	1
17.	72053508	ZERK 1/8 NPT	3
18.	72060893	CAP SCR 3/8-16X3-1/4 HHGR5	2
19.	72060921	CAP SCR 1/2-13X3-3/4 HHGR5	4
20.	72060147	CAP SCR 5/8-11X1 HHGR5	3
21.	72060148	CAP SCR 5/8-11X1-1/4 HHGR5	4

22.	72060217	CAP SCR 7/8-9X4 HHGR5	1
23.	52712181	PIN	1
24.	72060596	SET SCREW 1/2-13X3/4 SH	1
25.	72062103	NUT 3/8-16 LOCK	2
26.	72062080	NUT 1/2-13 LOCK	4
27.	72062120	NUT 7/8-9 LOCK	1
28.	52712183	RETAINER 3/4-10 HEX	1
29.	72063005	WASHER 1/2 WRT	4
30.	72063053	WASHER 1/2 LOCK	4
31.	72063055	WASHER 5/8 LOCK	4
32.	73051513	HYDRAULIC MOTOR	1
33.	72060064	CAP SCR 7/16-14X1-1/2 HHGR5	2
36.	60113593	COVER	1
37.	60113594	MOUNTING BLOCK	1
38.	72060008	CAP SCR 1/4-20X2 HHGR5	2
39.	72063049	WASHER 1/4 LOCK	4
40.	72063001	WASHER 1/4 FLAT	4
41.	77044468	STRAIN RELIEF	1
42.	51713168	CORD REEL	1
43.	72060000	CAP SCR 1/4-20X1/2 HHGR5	2
44.	77041291	SWITCH	1
45.	77040047	TERMINAL	1
46.	77040186	TERMINAL	1
47.	52709413	ANTI 2-BLOCK CABLE	1
48.	77040051	TERMINAL	2
49.	72063098	WASHER .16 FLAT	2
50.	72063047	WASHER #10 LOCK	2

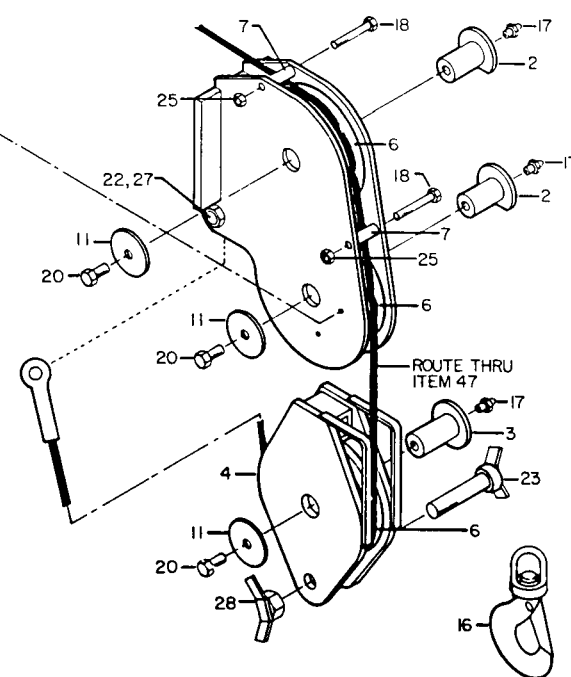
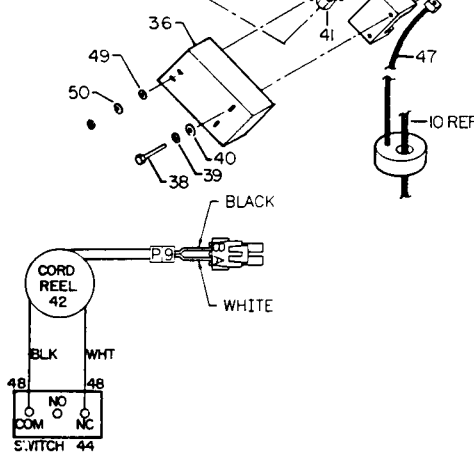
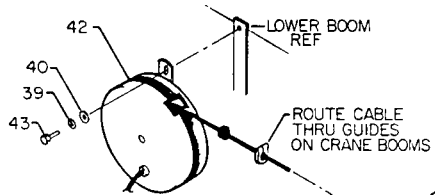
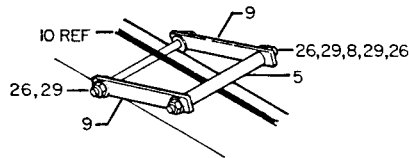
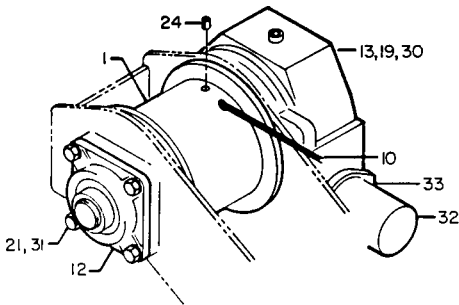

NOTE

Anytime the pin retainer bolts have been removed, apply serviceable thread locker to the threads before reassembly.

WINCH/CABLE/HOOK KIT W/ FLIP SHEAVE (31712207)

ITEM	PART NO.	DESCRIPTION	QTY
1.	52712162	WINCH DRUM	1
2.	52707730	PIN	1
3.	52707731	PIN	1
4.	52707735	SNATCH BLOCK	1
5.	60030108	ROLLER - CABLE GUIDE	1
6.	60030255	SHEAVE	3
7.	60102596	SPACER	2
8.	60105538	STUD- CABLE GUIDE	1
9.	60105540	CABLE GUIDE SIDE BAR	2
10.	70580089	CABLE 7/16 x 100' IWRC-XIP	1
11.	60109337	PIN RETAINER PLATE 3"	3
12.	70055117	BEARING, FLANGE	1
13.	70570198	WINCH	1
16.	70732882	HOOK-SW/VL POS LOCK 5.9TON	1
17.	72053508	ZERK 1/8 NPT	3
18.	72060893	CAP SCR 3/8-16X3-1/4 HHGR5	2
19.	72060921	CAP SCR 1/2-13X3-3/4 HHGR5	4
20.	72060147	CAP SCR 5/8-11X1 HHGR5	2
21.	72060148	CAP SCR 5/8-11X1-1/4 HHGR5	4
23.	52712181	PIN	1
24.	72060596	SET SCREW 1/2-13X3/4 SH	1
25.	72062103	NUT 3/8-16 LOCK	2
26.	72062080	NUT 1/2-13 LOCK	4
28.	52712183	RETAINER 3/4-10 HEX	1
29.	72063005	WASHER 1/2 WRT	4
30.	72063053	WASHER 1/2 LOCK	4
31.	72063055	WASHER 5/8 LOCK	4
32.	73051513	HYDRAULIC MOTOR	1
33.	72060064	CAP SCR 7/16-14X1-1/2 HHGR5	2

35.	72661367	PIN-QUICK	2
36.	60113593	COVER	1
37.	60113594	MOUNTING BLOCK	1
38.	72060008	CAP SCR 1/4-20X2 HHGR5	2
39.	72063049	WASHER 1/4 LOCK	4
40.	72063001	WASHER 1/4 FLAT	4
41.	77044468	STRAIN RELIEF	1
42.	51713168	CORD REEL	1
43.	72060000	CAP SCR 1/4-20X1/2 HHGR5	2
44.	77041291	SWITCH	1
45.	77040047	TERMINAL	1
46.	77040186	TERMINAL	1
47.	52709413	ANTI 2-BLOCK CABLE	1
48.	77040051	TERMINAL	2
49.	52709438	PIN	1
50.	52709458	WING BOLT	1
51.	60113679	LINK	1
52.	52709455	FLIP SHEAVE	1
53.	72661365	PIN W/HANDLE	2
54.	72063037	MACH BUSHING 1-1/2 10GA	2
55.	71073920	HOOK-3 TON SWIVEL	1
	70074000	SAFETY LATCH	REF
56.	72063098	WASHER .16 FLAT	2
57.	72063047	WASHER #10 LOCK	2

NOTE

Anytime the pin retainer bolts have been removed, apply serviceable thread locker to the threads before reassembly.

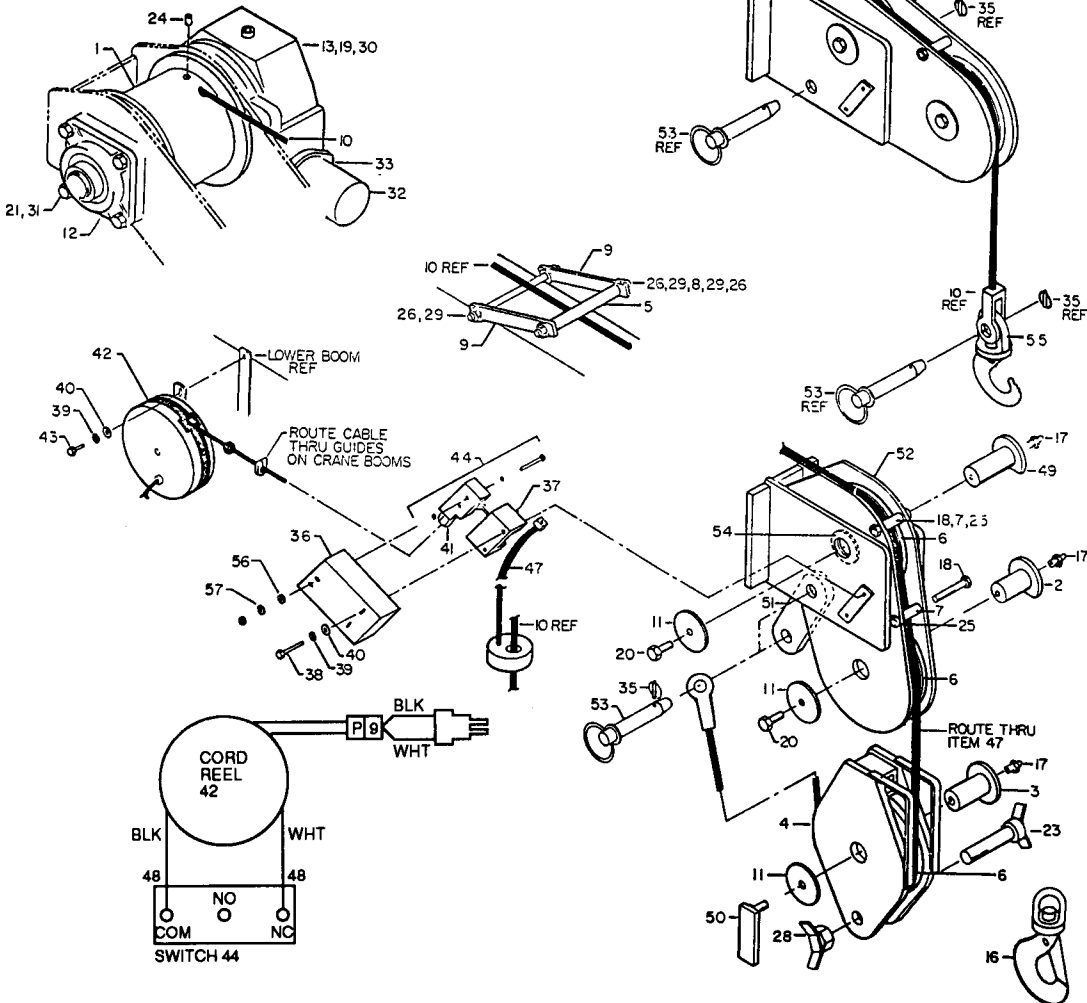

WINCH (70570198)

ITEM	PART NO.	DESCRIPTION	QTY
1.	72601568	CAP SCREW	8
2.	70143945	RETAINING RING	1
3.	70055220	BALL BEARING	2
4.	72661403	RETAINING RING	2
5.	70056522	WORM-SR	1
6.	70143865	PIPE PLUG	2
7.	70143946	THRUST WASHER	1
8.	70145384	OUTPUT SHAFT	1
9.	72601567	CAP SCREW	2
10.	70733135	BRAKE KIT (INCL:32-45)	1
11.	76393419	OIL SEAL	1
12.	70143948	BUSHING	1
13.	70143949	BUSHING	1
14.	70056521	WORM GEAR-SR	1
15.	70048156	BREATHER	1
16.	70143950	HOUSING	1
17.	76393420	O-RING	1
18.	70143951	COVER	1
19.	70029559	TAG-NAMEPLATE	1
22.	70143952	WASHER	1
23.	76394300	GASKET	1
24.	70143861	PIPE BUSHING	1
25.	76393171	GASKET	1
26.	—	PROTECTOR (DISCARD)	REF

30.	70145383	SPACER	1
31.	70145382	KEY	1
32.	70145381	*STATOR PLATE	3REF
33.	70145380	*FRICTION DISC	2REF
34.	70145379	*BRAKE HUB	1REF
35.	70143662	*CAM CLUTCH	1REF
36.	70145377	*WASHER	1REF
37.	72063188	*LOCKWASHER	1REF
38.	72601724	*CAP SCREW	1REF
39.	70145376	*BRAKE SPRING	1REF
40.	70143660	*THRUST WASHER	1REF
41.	70143666	*BRAKE HOUSING	1REF
42.	72601721	*CAP SCREW	2REF
43.	76393172	*WASHER-SEAL	1REF
44.	72601722	*LOCKNUT-SEAL	1REF
45.	72601723	*SET SCREW	8REF

* PART OF ITEM 10.

GEAR RATIO: 27:1
 OUTPUT TORQUE: 27328 IN-LBS
 MAX INPUT TORQUE: 2249 IN-LBS
 MAX INPUT SPEED: 316 RPM
 INSTALLED WEIGHT: 62 LBS
 LUBRICATION: EP 140

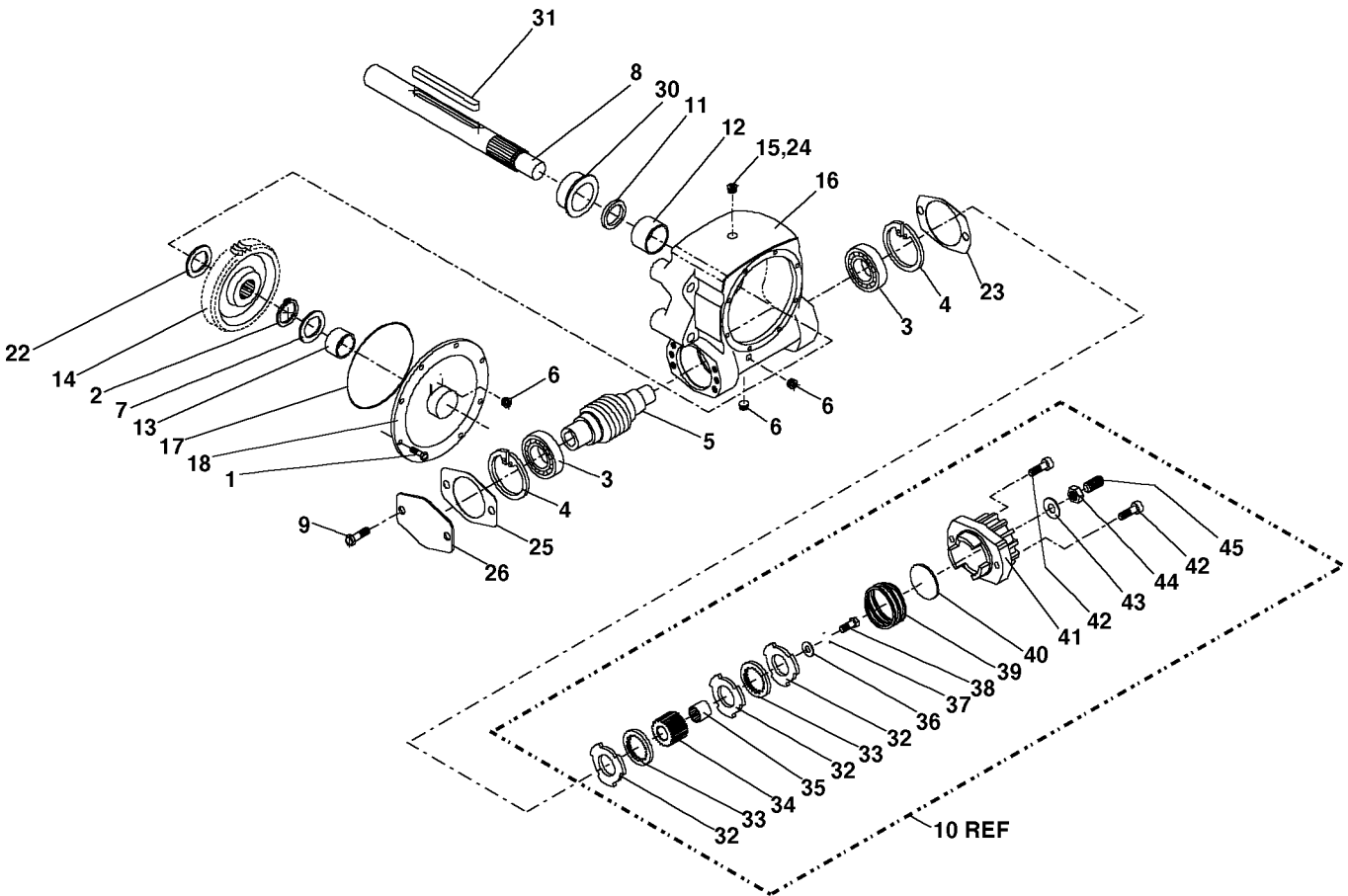

CORD REEL ASM (51713168)

ITEM	PART NO.	DESCRIPTION	QTY
1.	77044574	TOWER CONNECTOR	1
2.	77044552	PIN 18-20GA	2
3.	70394069	CABLE SEAL	2
4.	70732193	CORD REEL	1
5.	77041493	WIRE MARKER-PA2-P-YEL	1
6.	77041491	WIRE MARKER-PA2-9-YEL	1

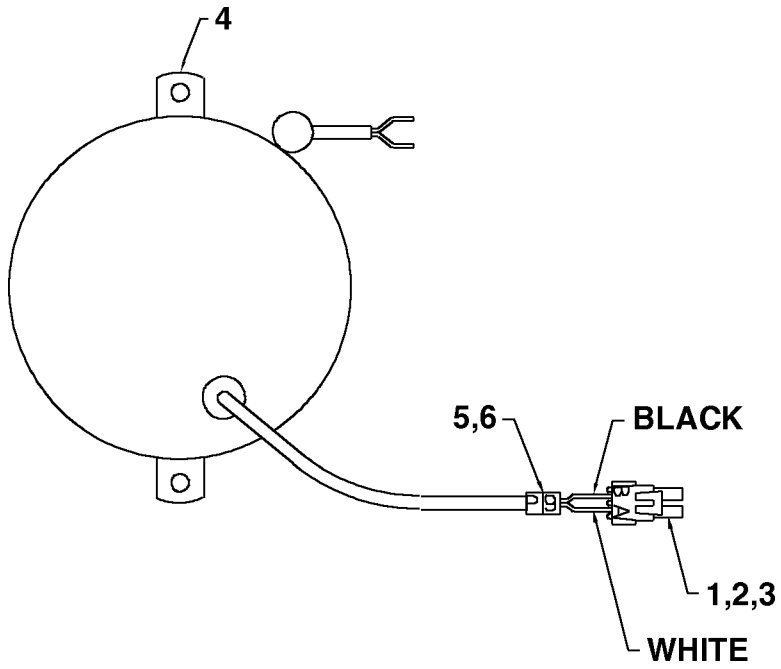

PROP'L RMT HANDLE ASM (51713182)

- 1. 89044214 WIRE 18GA GRN 1.61FT
- 2. 60119335 CONTROL HANDLE 1
- 3. 60111141 TRIGGER (PART OF 11) 1REF
- 4. 60119277 COVER 1
- 5. 70034306 BACK COVER 1
- 7. 77044196 STRAIN RELIEF 3/4 1
- 8. 77044621 PIN 23
- 9. 70394447 DECAL-DGR RC ELECTRO SM 1
- 10. 70394142 DECAL-CTRL 1
- 11. 70394183 TRIGGER ASM (INCL:3) 1

- 14. 72061009 SHT MTL SCR #6X3/4 PH 8
- 15. 77040051 TERM-SPRSPD #8 16-14GA 31
- 16. 77040371 TOGGLE SWITCH SPST 2
- 17. 77040372 TOGGLE SWITCH SPDT 4
- 18. 77040373 TOGGLE SWITCH SPST 2
- 19. 77040374 TOGGLE SWITCH SPDT 1
- 20. 77044579 CONNECTOR 1
- 21. 89044100 CABLE 18GA 24WIRE 30FT
- 22. 77040147 TERM-FSLPON 1/4TAB 22-18 3
- 23. 77040047 TERM-MSLPON 1/4TAB 16-14 3
- 24. 72060602 MACH SCR #6-32X3/8 RDHD 4
- 25. 70145495 TUBING-HEAT SHRINK .5FT

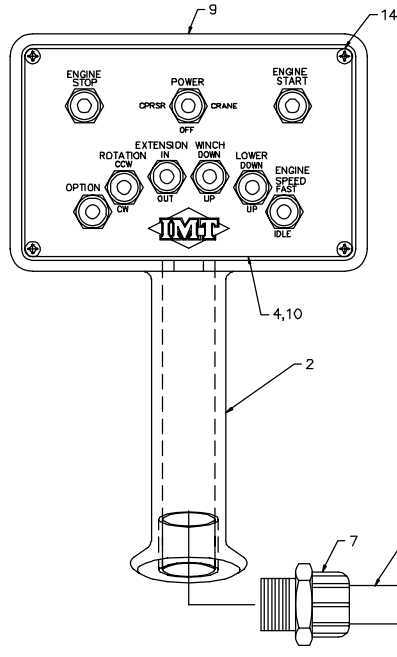

ASSEMBLY OF PROPORTIONAL TRIGGER

- 1) POSITION TRIGGER ASSEMBLY INTO HANDLE ASSEMBLY.
- 2) LOOKING FROM THE BACKSIDE OF THE HANDLE, INSTALL ONLY THE TWO SCREWS LOCATED ON THE LEFT-HAND SIDE OF THE TRIGGER ASSEMBLY. (TWO SCREWS ARE SUFFICIENT FOR HOLDING THE ASSEMBLY IN PLACE.) DO NOT FULLY TIGHTEN AT THIS POINT.
- 3) PUSH THE TRIGGER ASSEMBLY TOWARDS THE FRONT OF THE HOUSING, AS THE MOUNTING SCREW HOLES WILL ALLOW. TIGHTEN THE SCREWS FULLY AT THIS POINT.
- 4) CONNECT OHMMETER TO GREEN AND BLACK WIRES TO CHECK OHM READING. ALLOWABLE SETTING IS FROM 100 TO 320 OHMS. IF OTHER THAN THIS CONTACT QA.
- 5) FILL THE RIGHT HAND SCREWS WITH SILICONE, BLACK (IF AVAILABLE) OR CLEAR. (THIS WILL ELIMINATE THE CONCERN BY THE CUSTOMER THAT THE UNIT IS MISSING THE TWO SCREWS ON THE RIGHT SIDE.)
- 6) ASSEMBLY THE REST OF THE HANDLE.

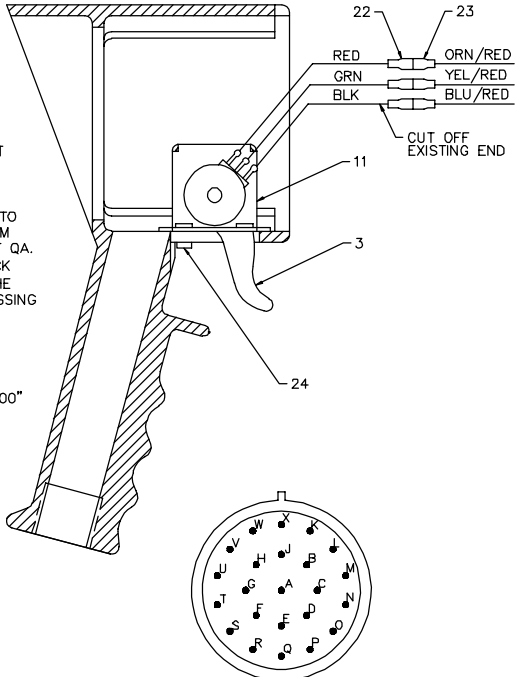

INSTALLATION NOTE:
 1) CUT WIRE CABLE OUTSIDE JACKET BACK 5.00"
 2) SLIP ON HEAT SHRINK
 3) MAKE WIRE CONNECTIONS
 4) PUSH HEAT SHRINK UP AND HEAT.

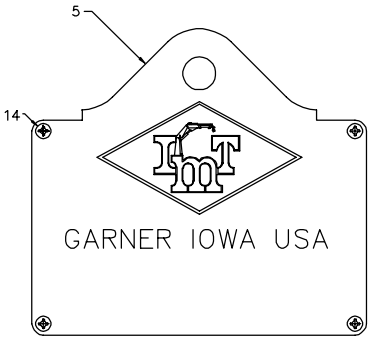
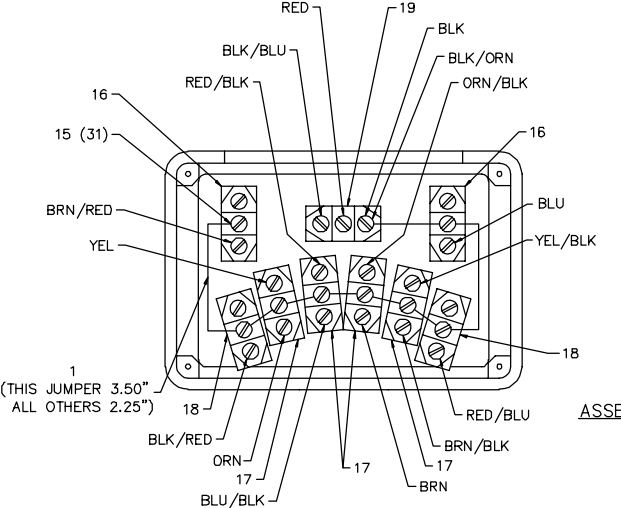

ASSEMBLY OF SWITCHES ONTO FACE PLATE.

- 1) INSTALL (1) STAR WASHER BETWEEN SWITCH & FACE PLATE.
- 2) INSTALL (1) LOCK NUT ON FRONT OF FACE PLATE TO RETAIN SWITCH.
- 3) DISCARD ALL OTHER MOUNTING HARDWARE.

SOLID/STRIPE	FUNCTION
A YEL/BLK	ROT CW
B ORN/BLK	EXT OUT
C BLU/BLK	WINCH DN
D RED/BLK	WINCH UP
E ORN/RED	-
F BRN	EXT IN
G BRN/RED	ENG START
H BLU/RED	-
J BLK/RED	ENG SPEED
K BRN/BLK	ROT CCW
L RED	POWER
M BLU	ENG STOP
N ORN	LOWER DN
O BLK/ORN	SOL POWER
P YEL	LOWER UP
Q BRN/BLU	-
R YEL/RED	-
S BLK	CRANE
T BLK/BLU	CRSR
U RED/BLU	OPTION
V BLU/ORN	-
W ORN/BLU	-
X YEL/BLU	-
- RED/ORN	-

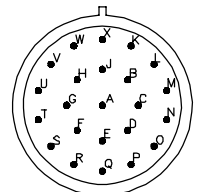

INSTALLATION KIT (93715067)

1.	72601748	CAP SCR 1-8X3 SHGR8	6
2.	72063066	WASHER 1" HI-STRGTH	12
3.	73052091	RETURN FILTER 10MIC (NOT SHOWN)	1
4.	60123848	WASHER-SPECIAL 1.0X2.0X1/4	6

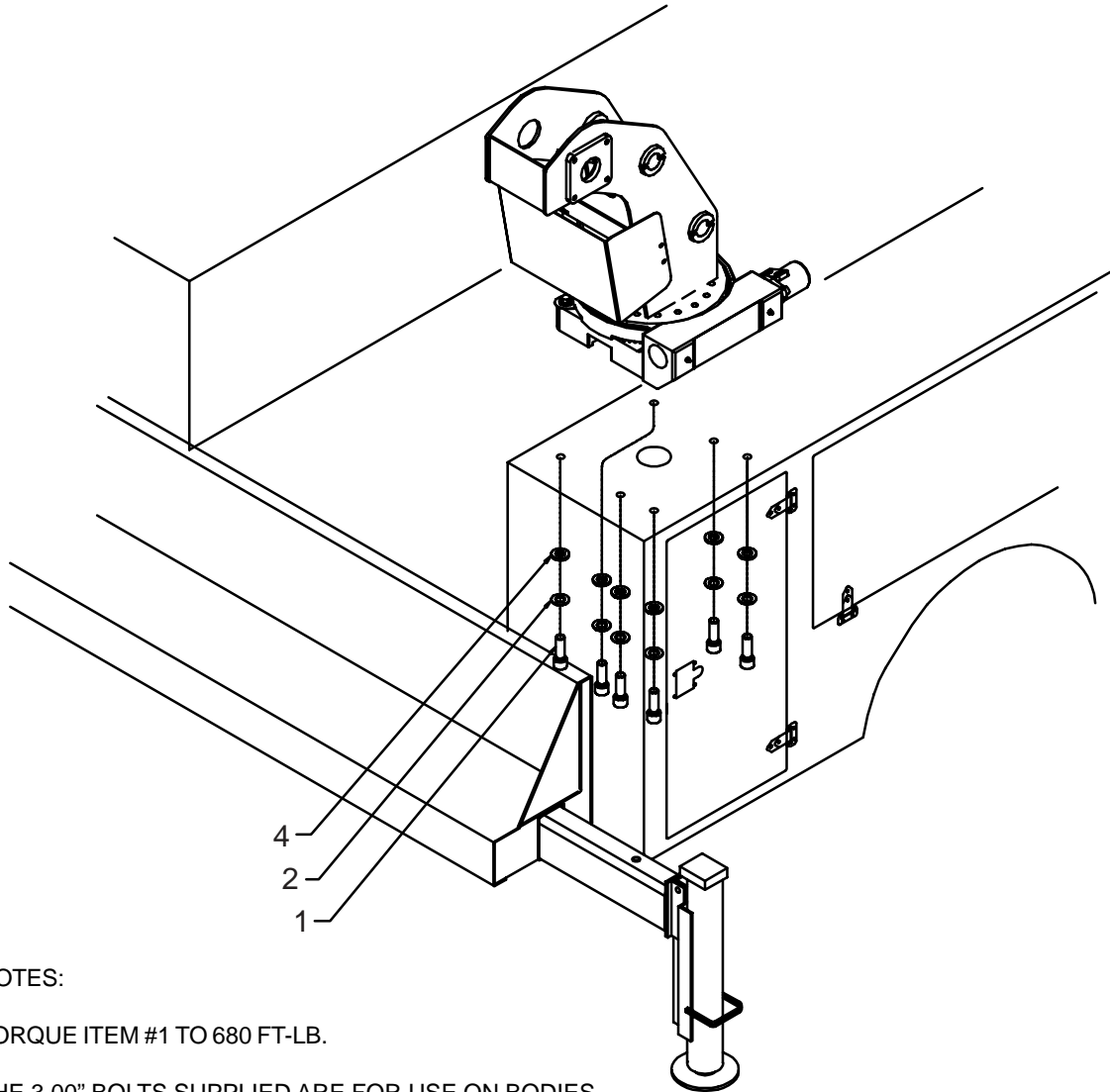
**NOTES:**

TORQUE ITEM #1 TO 680 FT-LB.

THE 3.00" BOLTS SUPPLIED ARE FOR USE ON BODIES WITH A CRANE BOX TOP PLATE THICKNESS OF 0.88 - 1.00" **ONLY!** ON SHIP-OUT CRANES, DETERMINE THE CRANE BOX TOP PLATE THICKNESS PRIOR TO MOUNTING THE CRANE. IF BOLTS OTHER THAN THE 3.00" SUPPLIED ARE REQUIRED, THEY MUST BE 1.00-8 GRADE 8 AND BE THE APPROPRIATE LENGTH.

FAILURE TO USE PROPER LENGTH BOLT MAY CAUSE THE CAP SCREWS UNDER THE WORM HOUSING TO BOTTOM OUT BEFORE BEING TORQUED. DURING TORQUEING, CHECK TO SEE THAT THE BOLTS GET TORQUED AND THAT THEY DO NOT BOTTOM OUT ON THE WORM HOUSING.

SIZE CAPSCREWS TO ENSURE A MINIMUM OF 1.50" THREAD ENGAGEMENT.

DECAL KIT (95715068)

- | | | | | | |
|--------------|---------------------------|---|--------------|--------------------------|---|
| 1. 70391598 | DECAL-WARNING OUTRIGGER | 2 | 18. 70392868 | DECAL-DANGER LOADLINE | 4 |
| 2. 70391612 | DECAL-GREASE WEEKLY LH | 3 | 19. 70029251 | DECAL-IMT DIAMOND | 2 |
| 3. 70391613 | DECAL-GREASE WEEKLY RH | 2 | 20. 70392888 | DECAL-DANGER RESTRICTION | 1 |
| 4. 70392108 | DECAL-SUCTION LINE | 1 | 21. 70394446 | DECAL-DANGER RC ELECTRO | 1 |
| 5. 70392109 | DECAL-RETURN LINE | 1 | 22. 70392891 | DECAL-DANGER DRIVELINE | 1 |
| 6. 70392213 | DECAL-CAUTION WASH/WAX | 1 | 23. 70392982 | DECAL-CONTACT IMT | 1 |
| 7. 70392524 | DECAL-ROTATE/GREASE | 1 | 24. 71039134 | DECAL-CAUTION OIL LEVEL | 1 |
| 8. 70395100 | DECAL-6020 IDENTIFICATION | 2 | 25. 71391522 | DECAL-ANGLE CHART RH | 1 |
| 9. 70394444 | DECAL-DGR ELECTROCUTION | 1 | 26. 71391523 | DECAL-ANGLE CHART LH | 1 |
| 10. 70392814 | DECAL-DANGER TRAINING | 1 | 27. 70395099 | CAPACITY CHART | 2 |
| 11. 70392815 | DECAL-DANGER OPERATION | 1 | 28. 70393860 | DECAL-LOAD BLOCK RATING | 2 |
| 12. 70392861 | DECAL-DANGER 2-BLOCKING | 1 | 29. 70394166 | DECAL-MANUAL OPERATION | 1 |
| 13. 70392863 | DECAL-DANGER HOIST PERS | 1 | 30. 70394189 | DECAL-RECOMMEND HYD OIL | 1 |
| 14. 70392864 | DECAL-DGR OR STAND CLEAR | 2 | 31. 70394443 | DECAL-DGR FREEFALL BOOM | 1 |
| 15. 70394445 | DECAL-DGR ELECTROCUTION | 4 | 32. 70392399 | DECAL-LUBE WORM | 1 |
| 16. 70392866 | DECAL-DANGER OPER COND | 1 | 33. 70395090 | DECAL-GREASE WORM DR | 1 |
| 17. 70392867 | DECAL-DANGER OR MOVING | 1 | 34. 70395324 | DECAL-ASME/ANSI B30.5 | 1 |

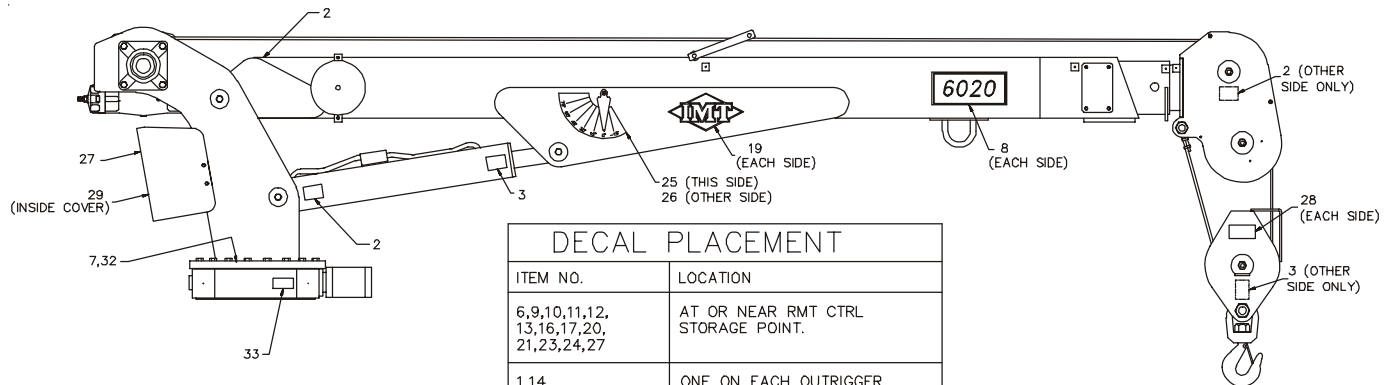

DECAL PLACEMENT	
ITEM NO.	LOCATION
6,9,10,11,12, 13,16,17,20, 21,23,24,27	AT OR NEAR RMT CTRL STORAGE POINT.
1,14	ONE ON EACH OUTRIGGER.
15,18	ONE ON EACH SIDE OF CARRIER VEHICLE.
5	ON RESERVOIR AT RETURN LINE.
4	ON RESERVOIR SUCTION LINE.
30	AT OR NEAR THE HYDRAULIC RESERVOIR.
22	AT OR NEAR THE DRIVELINE.
31	AT OR NEAR THE MANUAL BOOM EXT. RETENTION MECHANISM
34	PLACE UNDER SERIAL TAG

00006020: 51709256.01.19990104

OPTION-RESERVOIR (51709256)

FOR SHIPOUT APPLICATIONS ONLY

ITEM	PART NO.	DESCRIPTION	QTY
1.	52703440	RESERVOIR, 12 GAL.	1
2.	72053415	PLUG, 3/4 NPT	1
3.	72532261	PLUG, SIGHT GAUGE, 3/4 NPT	1
4.	73014671	CAP, FILL	1
5.	73141276	SCREEN, FILL NECK	1
6.	72060046	CAP SCREW, 3/8 X 1 GR5	6
7.	72062103	NUT, SELF LOCKING, 3/8	6
8.	73052012	SUCTION FILTER	1*
9.	72053211	PIPE NIPPLE	1*

* ITEMS 8 & 9 ARE SHIPPED LOOSE.

3-20

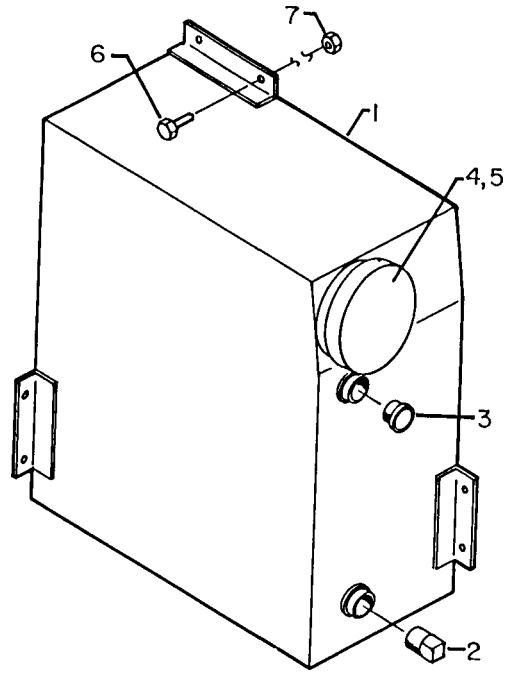

**OPTION-RESERVOIR 18 GAL-BULKHEAD
(51707798)**

1. 52711432	RESERVOIR WELDMENT	1
2. 72060104	CAP SCR 1/2-13X6-1/2 HHGR5	2
3. 72063005	WASHER 1/2 WRT	8
4. 72062080	NUT 1/2-13 LOCK	2
5. 70394189	DECAL-OIL RECOMMENDED	1
6. 70142482	FILL NECK STRAINER	1
7. 70142483	FILL CAP	1
8. 70393233	PLUG 3/4NPT	1

9. 72601004	PLUG 1-1/4NPT SQHD	1
10. 60119158	COVER PLATE	1
11. 76394152	GASKET 1/4X4.63X11.63 60 DUR.	1
12. 72061151	SCR, SELF-TAP W/SEAL 1/4X1.00 10	10
13. 70733058	DIFFUSER 33 GPM	1
14. 70394754	PLUG, PLASTIC 3/4 NPT	1
15. 72053305	COUPLING 3/4 STL	1
16. 70394753	PLUG, PLASTIC 1-1/4 NPT	1
17. 72053307	COUPLING, 1-1/4 STL	1
18. 70733059	STRAINER 20 GPM BYPASS	1

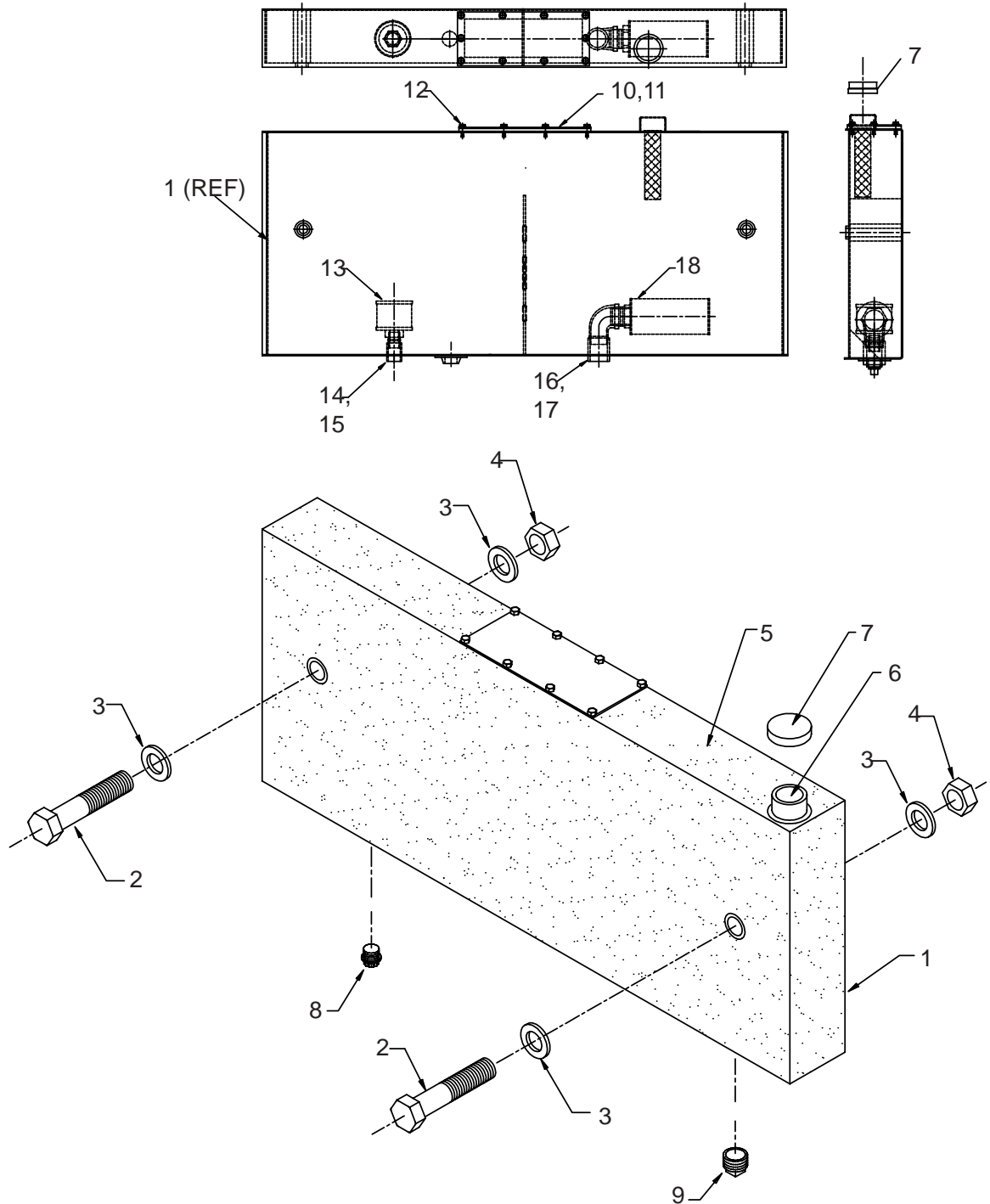

**OPTION-BOOM SUPPORT/RESERVOIR
20 GAL (51706910)**

ITEM	PART NO.	DESCRIPTION	QTY
1.	52705061	SADDLE	1
2.	52706909	RESERVOIR, 20 GAL.	1
3.	72060092	CAP SCREW, 1/2 X 1 1/4 GR5	4
4.	72063053	WASHER, LOCK, 1/2	4
5.	73014671	CAP, FILL	1
6.	73052001	PLUG, MAGNETIC, 3/4 NPT	1
7.	73141276	SCREEN, FILL NECK	1
8.	60030162	PAD, WEAR	1
9.	70086054	TAPE	12"
10.	60109252	TUBE, SADDLE	1
11.	72060195	CAP SCREW, 3/4 X 7 GR5	1
12.	72062114	NUT, SELF LOCKING, 3/4	1
13.	72532261	PLUG, SIGHT GAUGE, 3/4	1
14.	72060046	CAP SCREW, 3/8 X 1 GR5	4
15.	72062103	NUT, SELF LOCKING, 3/8	4
16.	72063003	WASHER, FLAT, 3/8	4
17.	76392821	SEAL, THREAD, 3/8	4
18.	73052012	SUCTION FILTER	1
19.	72053211	PIPE NIPPLE	1
20.	70394189	PLACARD-MOBOILOIL	1

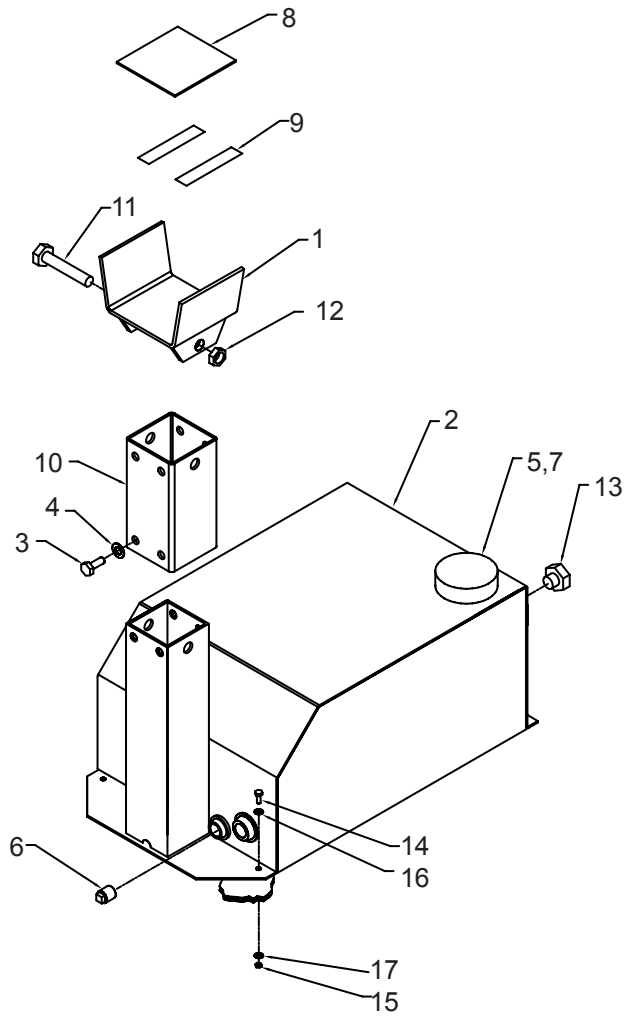

NOTE: ITEMS #18 AND 19 ARE SHIPPED
LOOSE WITH CRANE INSTALLATION KIT.

00006020: 51708161.01.19990104

OPTION-BOOM SUPPORT (51708161)

ITEM	PART NO.	DESCRIPTION	QTY
1.	52712318	SADDLE	1
2.	52708159	PEDESTAL	1
3.	60030294	WEAR PAD	1
4.	60112040	TUBE	1
5.	72060025	CAP SCR 5/16-18X1 HHGR5	2
6.	72060047	CAP SCR 3/8-16X1-1/4 HHGR5	4
7.	72060195	CAP SCR 3/4-10X7 HHGR5	1
8.	72062080	NUT 1/2-13 LOCK	2
9.	72062103	NUT 3/8-16 LOCK	4
10.	72062114	NUT 3/4-10 LOCK	1
11.	72063003	WASHER 3/8 WRT	4
12.	72063005	WASHER 1/2 WRT	2
13.	72063008	WASHER 3/4 WRT	2
14.	52708158	U-BOLT	1
15.	76392821	WASHER 3/8 BONDED	4
16.	72063001	WASHER 1/4 WRT	2
17.	72062109	NUT 5/16-18 LOCK	2

3-23

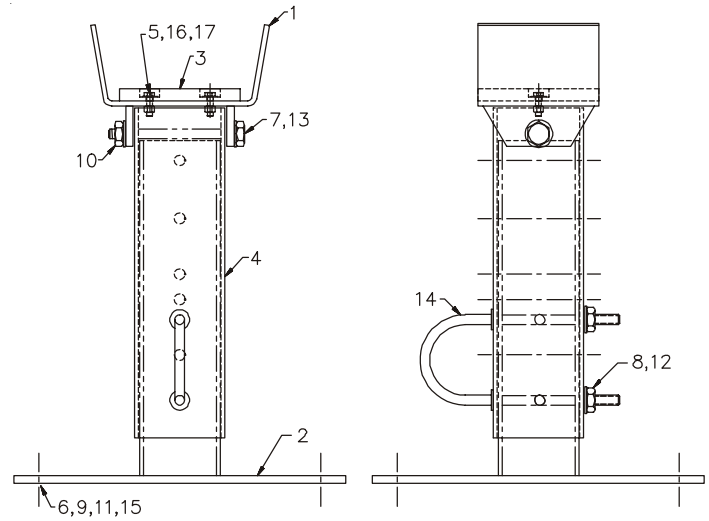

OPTION-AUX OUTRIGGERS-PO/PD-7X5 (31712739)

(Non-IMT Mechanic Service Body Application)

ITEM	PART NO.	DESCRIPTION	QTY
1.	3B205010	CYLINDER	2
2.	51396184	HOSE ASM 1/2X159 FF	1REF
3.	51395164	HOSE ASM 1/4X135 FJ	2REF
4.	51396280	HOSE ASM 1/4X96 FF	2REF
5.	51714812	VALVE BANK (INCL: 40)	1
6.	60118680	TUBE	1
7.	3B142860	POWER OUT CYLINDER	1
8.	52712735	ARM-ADJUSTABLE	1
9.	52712736	ARM-STATIONARY	1
10.	51396281	HOSE ASM 1/4X107 FJ	2REF
11.	72661472	PIN-SPRING 1/2X4	1
12.	51396282	HOSE ASM 3/4X51 FF	1REF
13.	72053758	ELBOW #4MSTR #4MJIC 90°	2
15.	72060025	CAP SCR 5/16-18X1 HHGR5	3
16.	72060107	CAP SCR 1/2-13X8 HHGR5	1
17.	72060155	CAP SCR 5/8-11X3-1/2 HHGR5	4
18.	72060833	SCR-5/16-18X3/4THRDCGTG(NOTE)	2
19.	72062080	NUT 1/2-13 HEX NYLOCK	2
20.	72062091	NUT 5/8-11 HEX NYLOCK	4
21.	72063002	WASHER 5/16W FLAT	5
22.	72063005	WASHER 1/2W FLAT	2
23.	72532351	ADPTR #4MSTR #4MJIC	4
24.	72601297	CAP SCR 1/2-13X5-3/4 HHGR5	1
25.	72066582	CLAMP (SEE NOTE)	2

28.	72531205	TEE-MALE JIC 3/4-16 1/2 TUBE	1
29.	72532658	ELBOW #8MJIC #8FJIC SW	1
30.	72532690	ELBOW #4MJIC #4FJIC SW	2
35.	72533623	ELBOW #8MSTR #12MJIC 90°	1
36.	71392277	DECAL-OUTRG POWER OUT	1
37.	76391511	DECAL-UP & DOWN STAB. R&L	1
38.	89034049	SPIRAL WRAP-BLK (SEE NOTE)	4'
39.	99900644	MANUAL-AUX OUTRG	1
40.	51731580	HANDLE ASM (INCLS: 34-41) (PART OF 5)	2REF
41.	70142648	PIVOT LEVER (PART OF 40)	2REF
42.	70142650	LEVER SUPPORT (PART OF 40)	2REF
43.	70142651	LEVER-CTRL HDL (PART OF 40)	2REF
44.	71392269	KNOB-CTRL HDL (PART OF 40)	2REF
45.	72062021	NUT 5/16-18 HEX (PART OF 40)	2REF
46.	72062024	NUT 1/2-13 HEX (PART OF 40)	2REF
47.	72066162	COTTER PIN (PART OF 40)	4REF
48.	72661204	PIN-CLEVIS (PART OF 40)	4REF
49.	51395431	HOSE ASM 1/2X96 FF	1REF
50.	72532972	ADPTR #8MJIC #12FJIC	1
51.	70392864	DECAL-DGR OUTRG STD CLR	2
52.	70392867	DECAL-DGR OUTRG (MOVING)	1
53.	71392257	DECAL-OUTRG PWR DWN SS	1
54.	72533567	ELBOW #4MSTR #4MJIC XLG	2
55.	51717834	HOSE KIT OR PO/PD (7X5 AUX KIT)	1

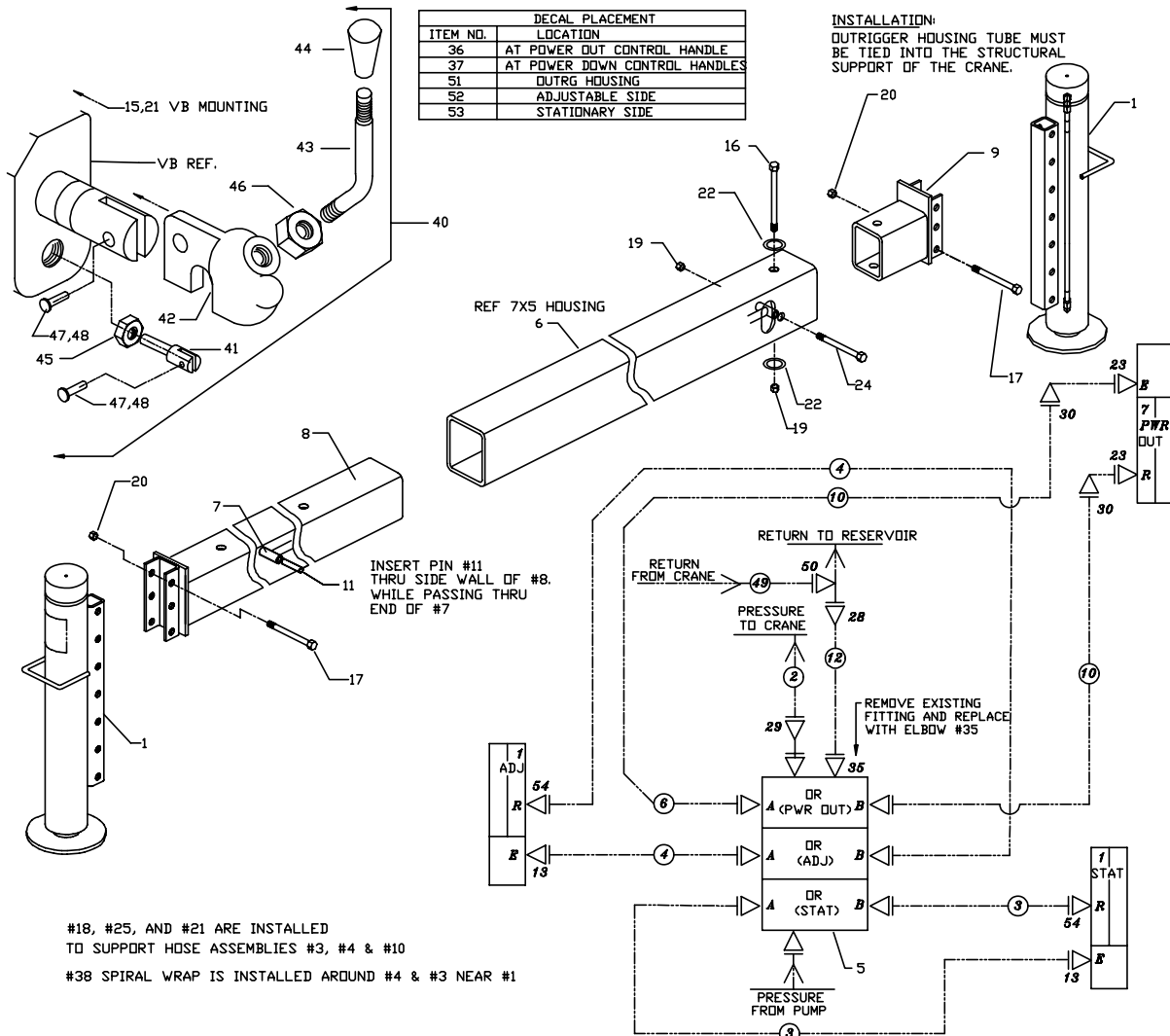

**OPTION-OUTRIGGER KIT-PO/PD-7X5
(31712731)**

ITEM	PART NO.	DESCRIPTION	QTY
1.	3B205010	CYLINDER	2
2.	51394690	HOSE 1/2X153 8F8F (PART OF 55)	1REF
3.	51394693	HOSE 1/4X130-1/2 4F4F (PART 55)	2REF
4.	51394691	HOSE 1/4X38-1/2 4F4F(PART OF 55)	2REF
5.	51705984	VALVEBANK 3-SECT (INCL:40)	1
6.	60118680	TUBE	1REF
7.	3B142860	CYLINDER-PWR OUT	1
8.	52712735	ARM-ADJUSTABLE	1
9.	52712736	ARM-STATIONARY	1
10.	51394914	HOSE 1/4X108 4F4F (PART OF 55)	2REF
11.	72661472	PIN	1
12.	51394915	HOSE 3/4X48 12F12F (PART OF 55)	1REF
13.	72053758	ELBOW #4MSTR #4MJIC 90°	2
14.	72053764	ELBOW #10MSTR #8MJIC 90°	1
15.	72060025	CAP SCR 5/16-18X1 HHGR5	3
16.	72060107	CAP SCR 1/2-13X8 HHGR5	1
17.	72060155	CAP SCR 5/8-11X3-1/2 HHGR5	4
18.	72060833	SCR 5/16-18X3/4 THRDCTG (NOTE)	2
19.	72062080	NUT 1/2-13 LOCK	2
20.	72062091	NUT 5/8-11 LOCK	4
21.	72063002	WASHER 5/16 WRT	5
22.	72063005	WASHER 1/2 WRT	2
23.	72532351	ADAPTER #4MSTR #4MJIC	2
24.	72601297	CAP SCR 1/2-13X5-3/4 HHGR5	1
25.	72066582	CLAMP (SEE NOTE)	2
26.	72532358	ADAPTER #8MSTR #8MJIC	1
27.	72532365	ADAPTER #10MSTR #12MJIC	1

28.	72531205	TEE 3/4MJIC 1/2TUBE	1
29.	72532658	ELBOW #8MJIC #8FJIC SW	1
30.	72532690	ELBOW #4MJIC #4FJIC SW	2
31.	72532699	ELBOW #6MSTR #4MJIC 90°	3
32.	72532700	ELBOW #6MSTR #6MJIC 90° XLG	3
33.	72532707	ADAPTER #4MJIC #6FJIC	3
34.	72532722	ADAPTER #10MSTR #6FSTR	6
35.	72532696	ELBOW #12MJIC #12FJIC SW	1
36.	71392277	DECAL-PWR OUT	1
37.	76391511	DECAL-STABILIZER	1
38.	89034049	SPIRAL WRAP (SEE NOTE)	4
39.	99900644	MANUAL-OUTRIGGER	1
40.	51731580	HANDLE (INCL:41-48,PART OF 5)	2REF
41.	70142648	PIVOT-LEVER (PART OF 40)	2REF
42.	70142650	LEVER SUPPORT (PART OF 40)	2REF
43.	70142651	LEVER-CTRL (PART OF 40)	2REF
44.	71392269	KNOB (PART OF 40)	2REF
45.	72062021	NUT 5/16-18 HEXJAM (PART OF 40)	2REF
46.	72062024	NUT 1/2-13 HEXJAM (PART OF 40)	2REF
47.	72066162	COTTER PIN (PART OF 40)	4REF
48.	72661204	CLEVIS PIN (PART OF 40)	4REF
49.	51394916	HOSE 1/2X99 8F8F (PART OF 55)	1REF
50.	72532972	ADAPTER #8MJIC #12FJIC	1
51.	72532980	ADAPTER #8JIC PR SW IN-LINE	1
52.	51394115	HOSE 1/4X59 4F4F (PART OF 55)	2REF
53.	72532690	ELBOW #4MJIC #4FJIC SW	4
54.	72533024	UNION-BULKHD #4JIC	2
55.	51714497	HOSE KIT-7X5 PO/PD OUTRG KIT (INCLS: 2,3,4,10,12,49,52)	1
56.	72533567	ELBOW #4MSTR #4MJIC XLG	2

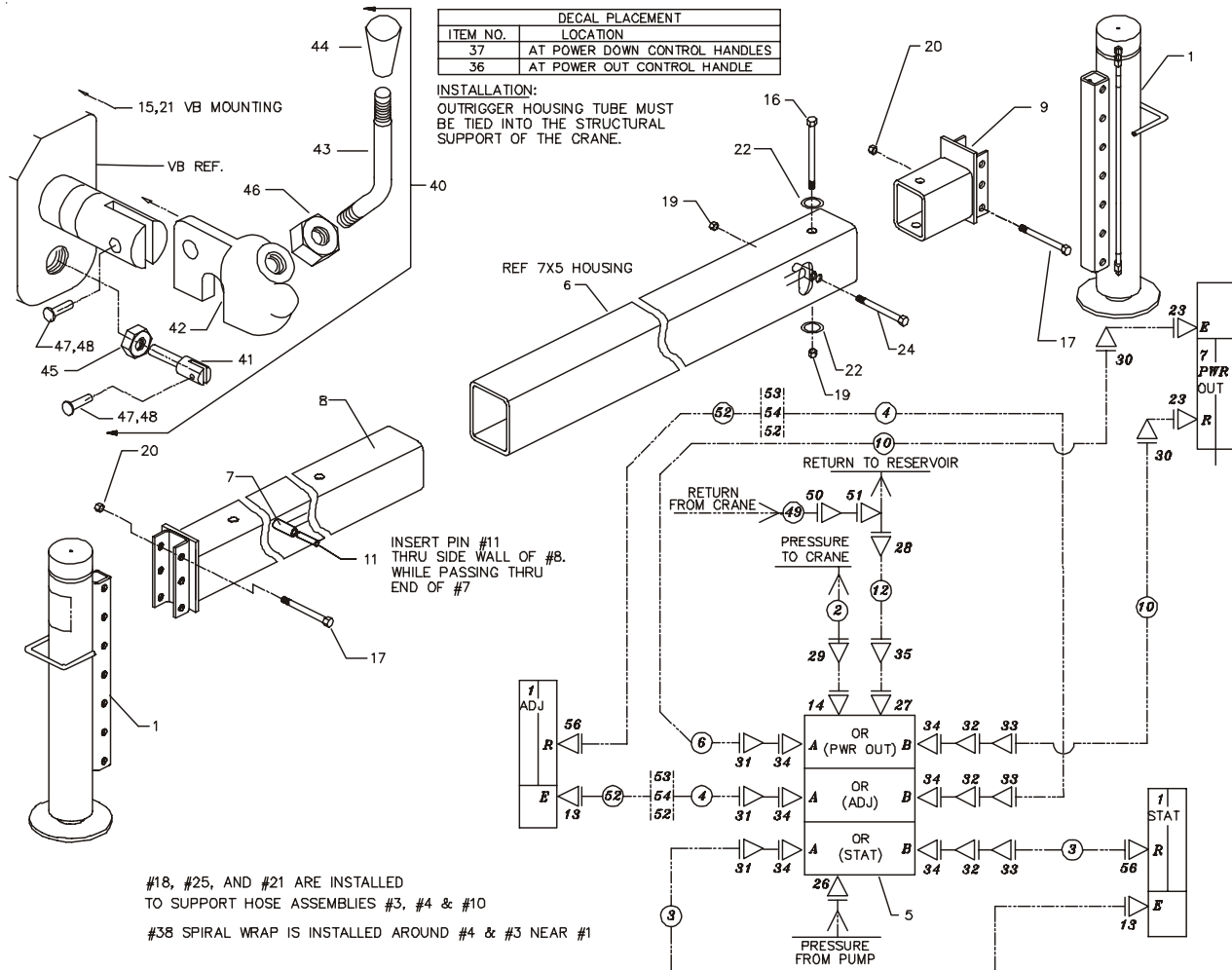

**OPTION-AUX OUTRIGGERS-MO/PD-7X5
(31712740) (EFF 9-03 - VB 51714813)**

- 1. 3B205010 CYLINDER 2
- 2. 51395431 HOSE-FF .50X 98.00 OAL(8- 8) 1
- 3. 51395552 HOSE-FJ .25X135.00 OAL(4- 4) 2
- 5. 51714813 VBASM 1
- 6. 51396280 HOSE-FJ .25X 96.00 OAL(4- 4) 2
- 7. 52070138 PIN-WLDMT - T 1
- 8. 52712735 ARM-OUTRG ADJ PWR DN 7X5 1
- 9. 52712736 ARM-OUTRG STAT PWR DN 7X5 1
- 10. 60010351 SPRING-"T" PIN 1
- 11. 51396184 HOSE-FF .50X159.00 OAL(8- 8) 1
- 12. 51396282 HOSE-FF .75X 51 OAL(12-12) 1
- 13. 72053758 ELBOW-M STR/90/M JIC 4 4 2
- 14. 72053764 ELBOW-M STR/90/M JIC 10 8 1
- 15. 72060025 CAP SCR .31-18X 1.00 HHGR5Z 3
- 16. 72060107 CAP SCR .50-13X 8.00 HHGR8Z 1
- 17. 72060155 CAP SCR .62-11X 3.50 HHGR5Z 4
- 18. 72060833 SCR-THD.CUT .31-18X.75 HWH-1 2
- 19. 72062080 NUT .50-13 HEX NYLOC ZINC 1
- 20. 72062091 NUT .62-11 HEX NYLOC ZINC 4
- 21. 72063002 WASHER .31 W FLAT 5
- 22. 72063005 WASHER .50 W FLAT 2
- 23. 72063027 MACHY BUSHING .62X14 GA NR 2
- 24. 72066185 COTTER PIN .16X1.00 PLAIN 1
- 25. 72066582 CLAMP-UMP20 S464-G20 2

- 26. 72532358 ADPTR-M STR/M JIC 8 8 1
- 27. 72532365 ADPTR-M STR/M JIC 10 12 1
- 28. 72531205 TEE-MALE JIC .75-16 .50 TUBE 1
- 29. 72532658 ELBOW-M JIC/F JIC SW 8 8 1
- 35. 72532696 ELBOW-M JIC/F JIC SW 12 12 1
- 37. 76391511 DECAL-UP & DOWN STAB 1
- 38. 89034049 SPIRAL WRAP-BLACK 4
- 39. 99900644 MANUAL-AUX OUTRIGGERS 1
- 40. 51731580 HANDLE ASM (INCL. 34-41) 2REF
- 41. 70142648 PIVOT-LEVER 2REF
- 42. 70142650 LEVER SUPPORT 2REF
- 43. 70142651 LEVER-CONTROL HANDLE 2REF
- 44. 71392269 KNOB-CONTROL HANDLE 2REF
- 45. 72062021 NUT 5/16-18 HEX JAM 2REF
- 46. 72062024 NUT 1/2-13 HEX JAM 2REF
- 47. 72066162 COTTER PIN 4REF
- 48. 72661204 PIN, CLEVIS 4REF
- 49. 72532972 ADPTR #8MJIC #12FJIC 1
- 50. 72532980 SWIVEL-M JIC/F JIC 8 8 IN-LINE 1
- 51. 52712734 HOUSING-OUTRG AUX 7X5 1
- 52. 70392864 DECAL-DANGER OUTRG STAND 2
- 53. 70392867 DECAL-DANGER OUTRG (MOV) 1
- 54. 71392257 DECAL-OUTRG POWER DN SS 1
- 56. 72533567 ELBOW-M STR/M JIC XLG 4 4 2

DECAL PLACEMENT	
ITEM NO.	LOCATION
37	AT PWR DN CTRL HANDLES
52	OUTRG HOUSING
53	ADJUSTABLE SIDE
54	STATIONARY SIDE
55	AT PWR OUT CTRL HANDLE

INSTALLATION:
OUTRIGGER HOUSING TUBE MUST BE TIED INTO THE STRUCTURAL SUPPORT OF THE CRANE.

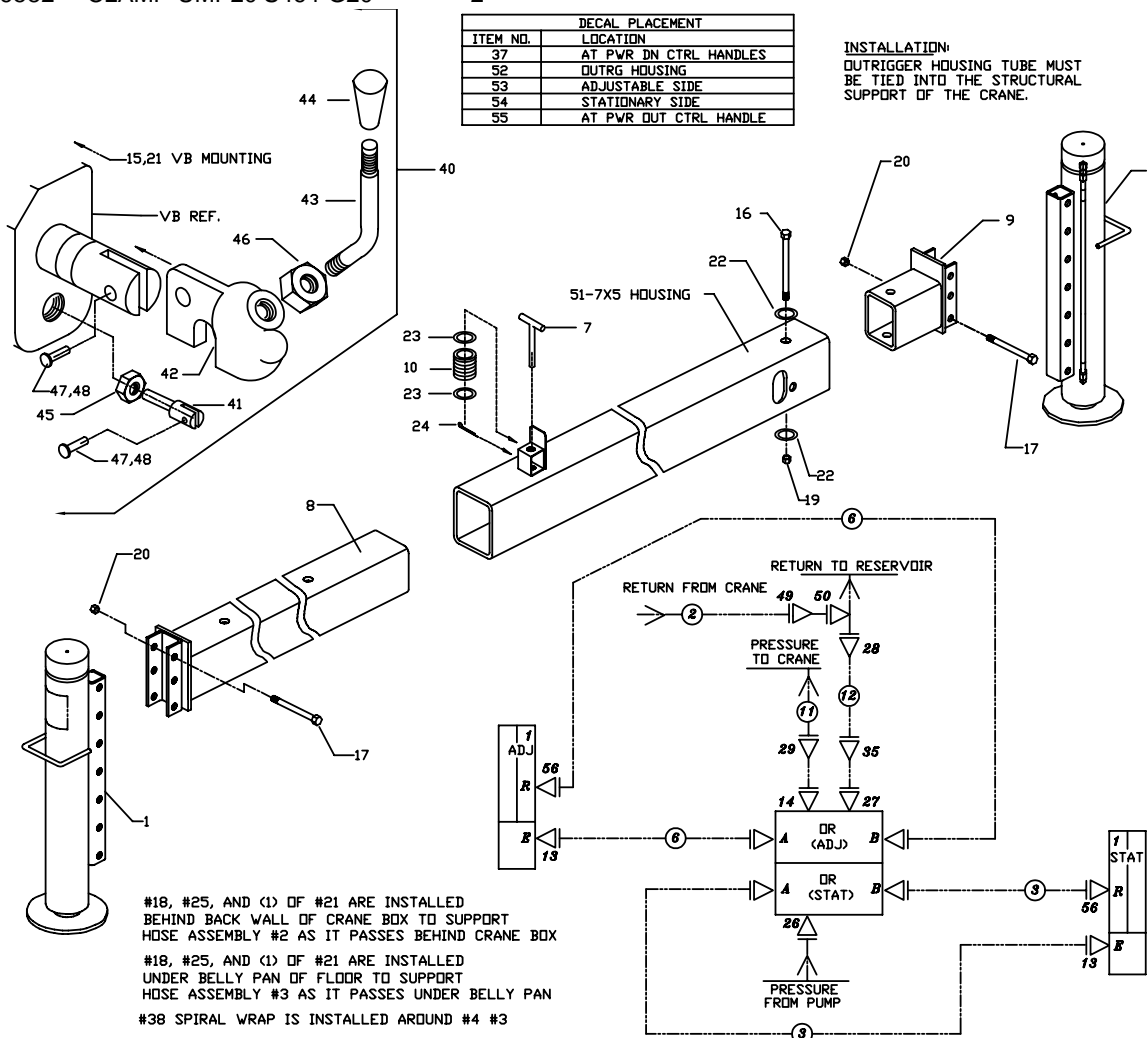

**OPTION-AUX OUTRIGGERS-MO/PD-7X5
(31712740) (THRU 9-03 - VB 51705983)**

(Non-IMT Mechanic Service Body Application)

ITEM	PART NO.	DESCRIPTION	QTY
1.	3B205010	CYLINDER	2
2.	51703939	HOSE 1/2X96 FF	1
3.	51705364	HOSE 1/4X128 FF	2
4.	51705365	HOSE 1/4X56 FF	2
5.	51705983	VALVEBANK 2-SECT (INCLS: 40)	1
6.	51706152	HOSE 1/4X36 FF	2
7.	52070138	T-PIN	1
8.	52712735	ARM-ADJUSTABLE	1
9.	52712736	ARM-STATIONARY	1
10.	60010351	SPRING	1
11.	51705639	HOSE 1/2X150 FF	1
12.	51703296	HOSE 3/4X48 FF	1
13.	72053758	ELBOW #4MSTR #4MJIC 90°	2
14.	72053764	ELBOW #10MSTR #8MJIC 90°	1
15.	72060025	CAP SCR 5/16-18X1 HHGR5	3
16.	72060107	CAP SCR 1/2-13X8 HHGR5	1
17.	72060155	CAP SCR 5/8-11X3-1/2 HHGR5	4
18.	72060833	SCR 5/16-18X3/4THRDCTG(NOTE)	2
19.	72062080	NUT 1/2-13 LOCK	1
20.	72062091	NUT 5/8-11 LOCK	4
21.	72063002	WASHER 5/16W FLAT	5
22.	72063005	WASHER 1/2W FLAT	2
23.	72063027	BUSHING-MACH	2
24.	72066185	COTTER PIN 5/32X1	1
25.	72066582	CLAMP (SEE NOTE)	2
26.	72532358	ADPTR #8MSTR #8MJIC	1

27.	72532365	ADPTR #10MSTR #12MJIC	1
28.	72531205	TEE-MJIC 3/4-16 1/2TUBE	1
29.	72532658	ELBOW #8MJIC #8FJIC SW	1
30.	72532690	ELBOW #4MJIC #4FJIC SW	4
31.	72532699	ELBOW #6MSTR #4MJIC 90°	2
32.	72532700	ELBOW #6MSTR #6MJIC XLG 90°	2
33.	72532707	ADPTR #4MJIC #6FJIC	2
34.	72532722	ADPTR #10MSTR #6FSTR	4
35.	72532696	ELBOW #12MJIC #12FJIC SW	1
36.	72533024	UNION	2
37.	76391511	DECAL-UP & DOWN STAB R&L	1
38.	89034049	SPIRAL WRAP-BLK (SEE NOTE)	4'
39.	99900644	MANUAL-AUX OUTRGS	1
40.	51731580	HANDLE ASM (INCL:34-41) (PART OF 5)	2REF
41.	70142648	LEVER PIVOT (PART OF 40)	2REF
42.	70142650	LEVER SUPPORT (PART OF 40)	2REF
43.	70142651	LEVER (PART OF 40)	2REF
44.	71392269	KNOB (PART OF 40)	2REF
45.	72062021	NUT 5/16-18 JAM (PART OF 40)	2REF
46.	72062024	NUT 1/2-13 JAM (PART OF 40)	2REF
47.	72066162	COTTER PIN (PART OF 40)	4REF
48.	72661204	CLEVIS PIN (PART OF 40)	4REF
49.	72532972	ADPTR #8MJIC #12FJIC	1
50.	72532980	ADPTR PR SW IN-LINE 3/4JIC	1
51.	52712734	OUTRG HSG 7X5	1
52.	70392864	DECAL-DGR STAND CLEAR	2
53.	70392867	DECAL-DGR OUTRG MOVING	1
54.	71392257	DECAL-OUTRG PWR DWN SS	1
55.	71392277	DECAL-OUTRG PWR OUT	1
56.	72533567	ELBOW #4MSTR #4MJIC XLG	2

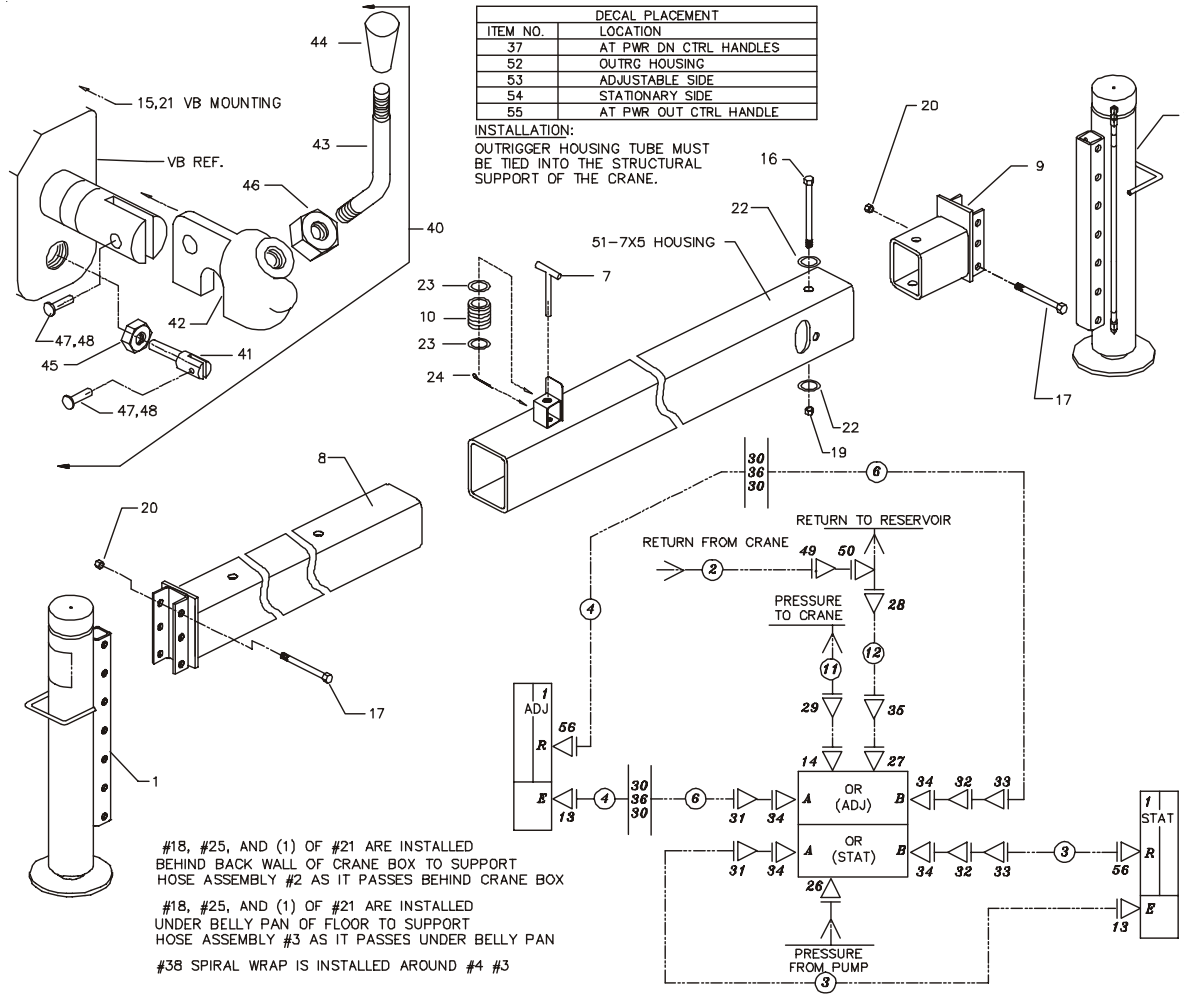

**OPTION-OUTRIGGER KIT-MO/PD-7X5
(31712732)**

ITEM	PART NO.	DESCRIPTION	QTY
1.	3B205010	CYLINDER	2
2.	51394916	HOSE 1/2X99 8F8F (PART OF 51)	1
3.	51394693	HOSE 1/4X130-1/2 4F4F (PART 51)	2
4.	51394115	HOSE 1/4X59 4F4F (PART OF 51)	2
5.	51705983	VALVEBANK 2-SECT (INCL:40)	1
6.	51394691	HOSE 1/4X38-1/2 4F4F (PART 51)	2
7.	52070138	T-PIN	1
8.	52712735	ARM-ADJUSTABLE	1
9.	52712736	ARM-STATIONARY	1
10.	60010351	SPRING	1
11.	51394690	HOSE 1/2X153 8F8F (PART OF 51)	1
12.	51394689	HOSE 3/4X51 12F12F (PART OF 51)	1
13.	72053758	ELBOW #4MSTR #4MJIC 90°	2
14.	72053764	ELBOW #10MSTR #8MJIC 90°	3
15.	72060025	CAP SCR 5/16-18X1 HHGR5	1
16.	72060107	CAP SCR 1/2-13X8 HHGR5	1
17.	72060155	CAP SCR 5/8-11X3-1/2 HHGR5	4
18.	72060833	SCR-5/16-18X3/4THRDCTG(NOTE)	2
19.	72062080	NUT 1/2-13 LOCK	1
20.	72062091	NUT 5/8-11 LOCK	4
21.	72063002	WASHER 5/16W FLAT	5
22.	72063005	WASHER 1/2W FLAT	2
23.	72063027	BUSHING-MACHY 5/8X14GA	2
24.	72066185	COTTER PIN 5/32X1	1
25.	72066582	CLAMP (SEE NOTE)	2

26.	72532358	ADAPTER MSTR MJIC	1
27.	72532365	ADPTR #10MSTR #12MJIC	1
28.	72531205	TEE MJIC 3/4-16 1/2TUBE	1
29.	72532658	ELBOW #8MJIC #8FJIC SWVL	1
30.	72532690	ELBOW #4MJIC #4FJIC SWVL	4
31.	72532699	ELBOW #6MSTR #4MJIC 90°	2
32.	72532700	ELBOW #6MSTR #6MJIC XLG 90°	2
33.	72532707	ADPTR #4MJIC #6FJIC	2
34.	72532722	ADPTR #10MSTR #6FSTR	4
35.	72532696	ELBOW #12MJIC #12FJIC SWVL	1
36.	72533024	BULKHEAD UNION #4JIC	2
37.	76391511	DECAL-UP & DWN STAB R&L	1
38.	89034049	SPIRAL WRAP-BLK (SEE NOTE)	4
39.	99900644	MANUAL-AUX OUTRGS HANDLE ASM	1
40.	51731580	(INCL:34-41)(PART OF 5)	2REF
41.	70142648	LEVER PIVOT (PART OF 40)	2REF
42.	70142650	LEVER SUPPORT (PART OF 40)	2REF
43.	70142651	LEVER (PART OF 40)	2REF
44.	71392269	KNOB (PART OF 40)	2REF
45.	72062021	NUT 5/16-18 JAM (PART OF 40)	2REF
46.	72062024	NUT 1/2-13 JAM (PART OF 40)	2REF
47.	72066162	COTTER PIN (PART OF 40)	4REF
48.	72661204	CLEVIS PIN (PART OF 40)	4REF
49.	72532972	ADPTR #8MJIC #12FJIC	1
50.	72532980	ADAPTER 3/4JIC IN-LINE PR SW	1
51.	51714498	HOSE KIT (INCL: 2,3,4,6,11,12)	1
52.	72533567	ELBOW #4MSTR #4MJIC XLG	2

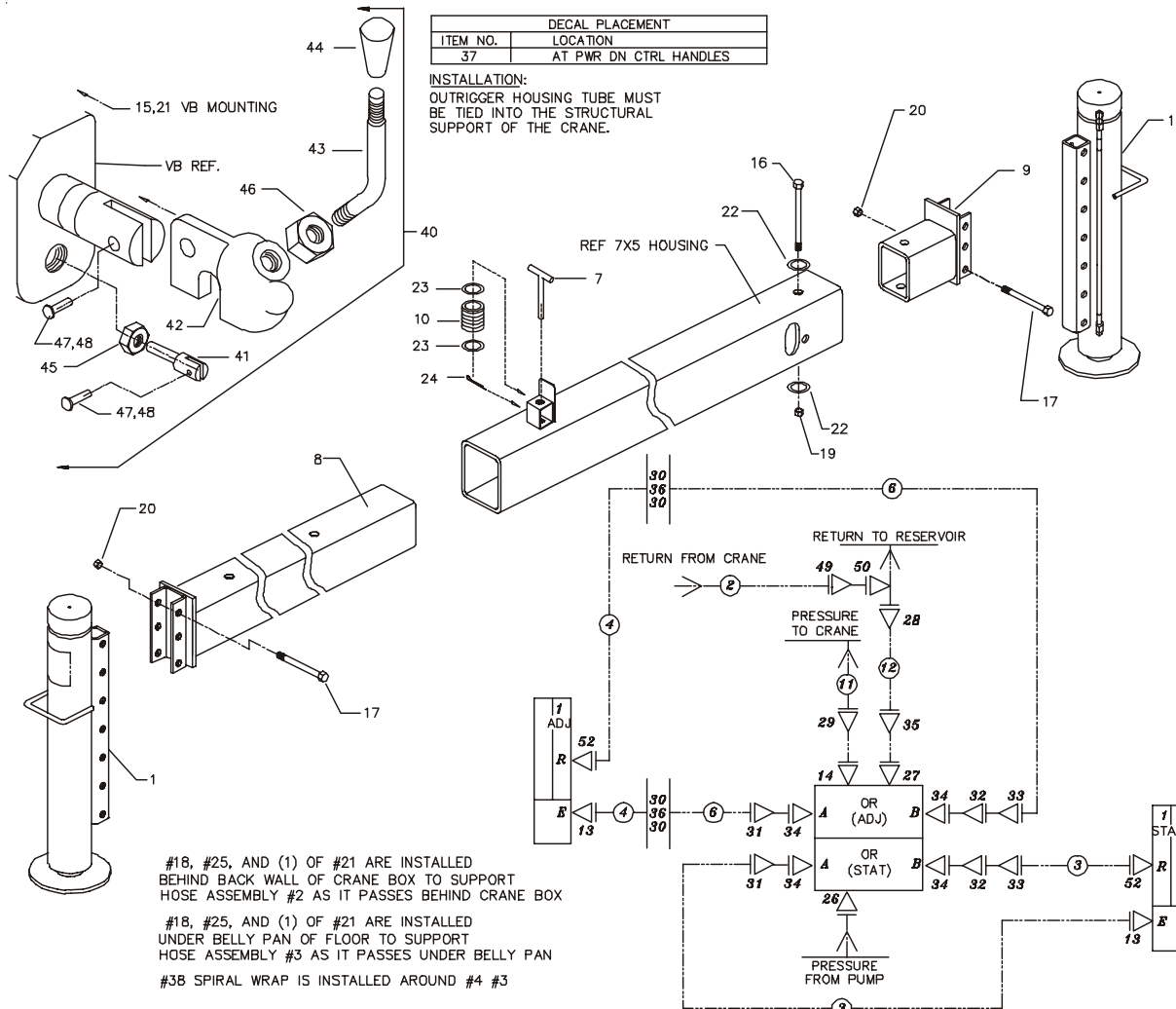

**OPTION-AUX OUTRIGGERS-MO/CRANK
DN-7X5 (31712741)**

INSTALLATION NOTE

OUTRIGGER HOUSING TUBE MUST BE TIED INTO THE STRUCTURAL SUPPORT OF THE CRANE.

(Non-IMT Mechanic Service Body Application)

ITEM	PART NO.	DESCRIPTION	QTY
1.	51705040	CRANK ASM (INCL:11-14)	1
2.	52070138	T-PIN	1
3.	52712734	OUTRIGGER HOUSING 7X5	1
4.	52712737	ARM-ADJUSTABLE	1
5.	52712738	ARM-STATIONARY	1
6.	60010351	SPRING	1
7.	72060107	CAP SCR 1/2-13X8 HHGR5	1
8.	72062080	NUT 1/2-13 LOCK	1
9.	72063007	WASHER 5/8 WRT	2
10.	72066185	COTTER PIN 5/32X1	1
11.	52705039	CRANK (PART OF 1)	1REF
12.	60030099	ROLLER (PART OF 1)	1REF
13.	72063003	WASHER 3/8 WRT (PART OF 1)	2REF
14.	72062103	NUT 3/8-16 LOCK (PART OF 1)	1REF
15.	52703319	CRANK HANDLE	1
16.	71039096	KNOB	1
17.	70392864	DECAL-DANGER STAND CLEAR	2

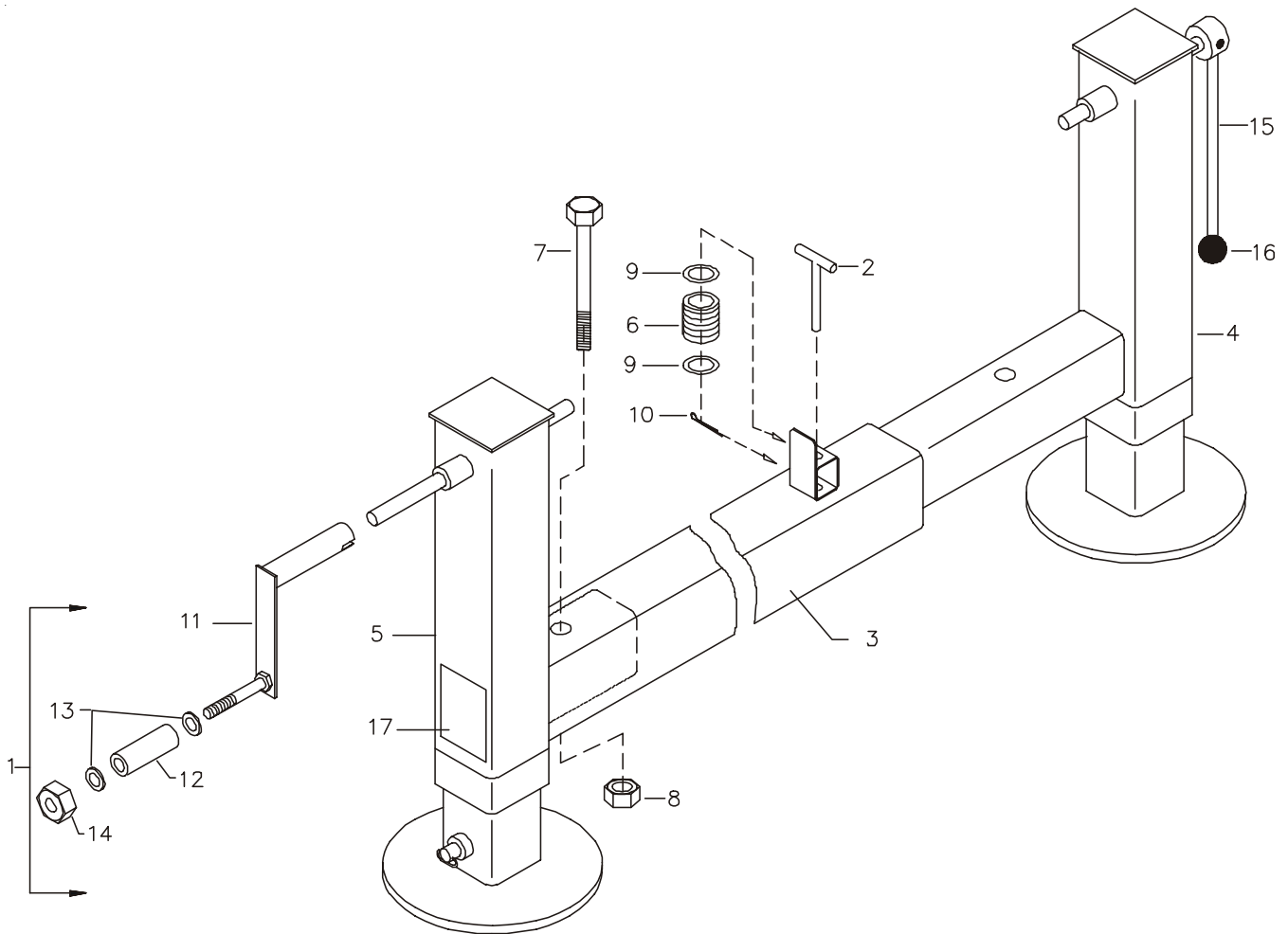

**OPTION-OUTRIGGER KIT-MO/CRANK
DN-7X5 (31718953)**

ITEM	PART NO.	DESCRIPTION	QTY
1.	52712737	ARM, ORADJ MAN CRANK	1
2.	5212738	ARM, OR STAT MAN CRANK	1
3.	60106314	PIN	1
4.	60030053	ROLLER	1
5.	52705039	CRANK, WELDMENT	1
6.	52703319	CRANK HANDLE, WLDMT	1
7.	71039096	KNOB, CONTROL	1
8.	60030099	ROLLER	1
9.	52718725	PIN WELDMENT	1

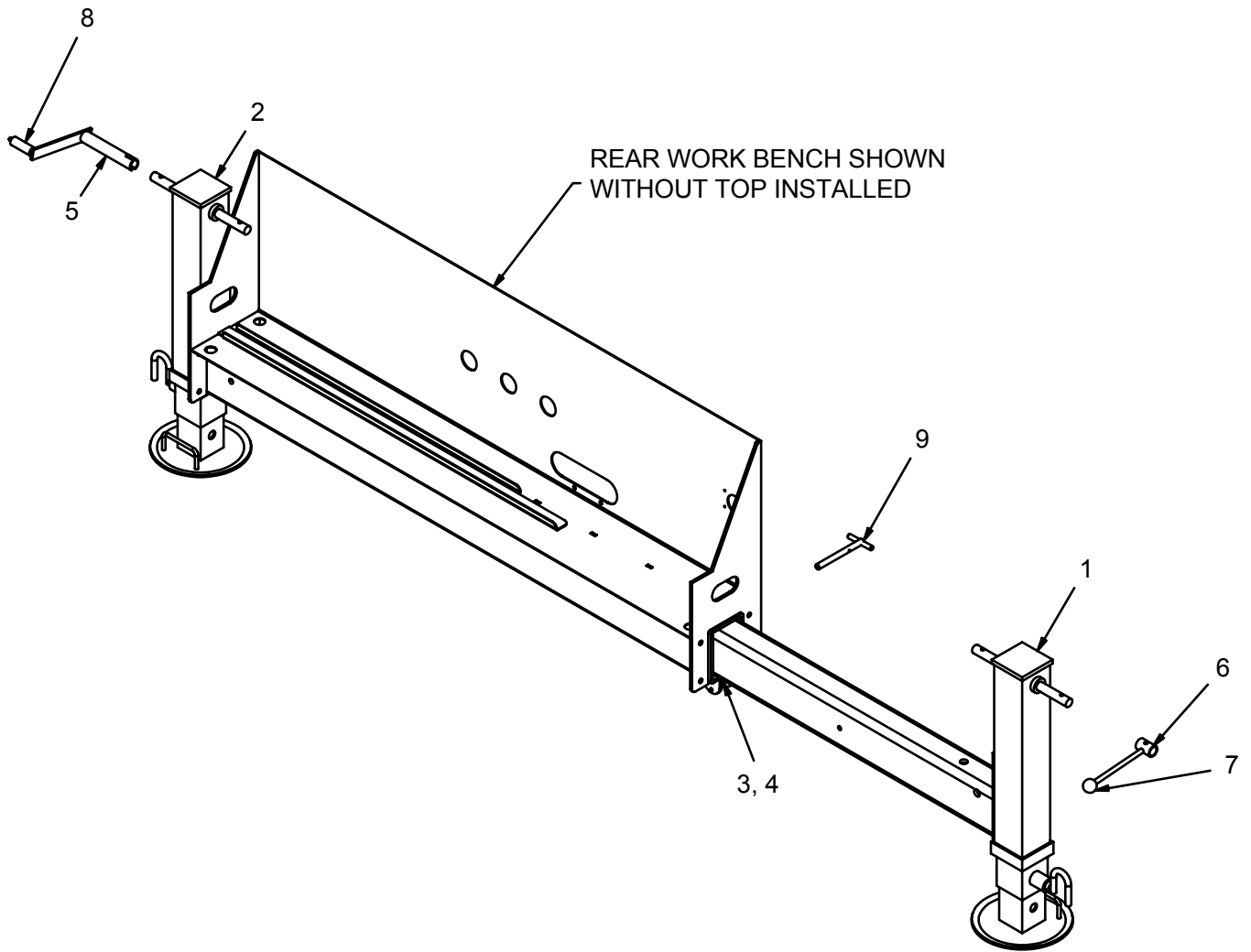

OPTION-OUTRIGGER KIT-ELECTRIC PO/ MD-7X5 (31712886)

ITEM	PART NO.	DESCRIPTION	QTY
1.	3B205010	CYLINDER	2
2.	51710569	HOSE ASM 1/4X36 FF	2
3.	51704024	HOSE ASM 1/4X54 FF	2
4.	51705364	HOSE ASM 1/4X128 FF	2
5.	51703939	HOSE ASM 1/2X96 FF	1
6.	51707005	HOSE ASM 3/4X39 FF	1
7.	73732445	VALVEBANK 2-SECT 7GPM	1
8.	60114313	GUARD-SWITCH BOX	1*
9.	52712735	ARM-ADJUSTABLE	1
10.	52712736	ARM-STATIONARY	1
11.		OUTRIGGER HOUSING	REF
12.	72532980	ADAPTER #8JIC IN-LINE PR SW	1
13.	72060107	CAP SCR 1/2-13X8 HHGR5	1
14.	72060155	CAP SCR 5/8-11X3-1/2 HHGR5	4
15.	72062080	NUT 1/2-13 LOCK	1
16.	72062091	NUT 5/8-11 LOCK	4
17.	72063005	WASHER 1/2 WRT	2
18.	72532695	TEE #12MJIC 3/4TUBE	1
20.	72533024	UNION #4JIC 37° W/NUT	2
21.	72532365	ADAPTER #10MSTR #12MJIC	1
22.	72532722	ADAPTER #10MSTR #6FSTR	4
23.	72532358	ADAPTER #8MSTR #8MJIC	1

24.	72532707	ADAPTER #4MJIC #6MJIC	2
25.	72053764	ELBOW #10MSTR #8MJIC 90°	1
26.	72532700	ELBOW #6MSTR #6MJIC XLG 90°	2
27.	72053758	ELBOW #4MSTR #4MJIC 90°	2
28.	72532699	ELBOW #6MSTR #4MJIC 90°	2
29.	72532690	ELBOW #4MJIC #4FJIC SWVL	4
30.	70392864	DECAL-DANGER STAND CLEAR	2
31.	70392867	DECAL-DGR OUTRGR MOVING	1
32.	71392257	DECAL-CONTROL PD SS	1
33.	70393467	DECAL-SELECTOR VALVE	1
34.	71392971	DECAL-CTRL LH	1
35.	71392972	DECAL-CTRL RH	1
36.	73054420	SELECTOR VALVE 24GPM	1*
37.	77040137	TERMINAL 1/4 FSLPON 12-10GA	4*
38.	77040186	TERMINAL 1/4 FSLPON 16-14GA	6*
39.	77041197	JIC BOX	1*
40.	77041345	TOGGLE SWITCH-SGL THROW	1*
41.	77041346	TOGGLE SWITCH-DBL THROW	2*
42.	89044354	CABLE-14GA 6WIRE	5*
43.	72066185	COTTER PIN .16X1	1
44.	72063027	MACH BUSHING 5/8	2
45.	60010351	SPRING	1
46.	52070138	T-PIN	1
47.	72533567	ELBOW #4MSTR #4MJIC XLG	2

* NOT SHOWN

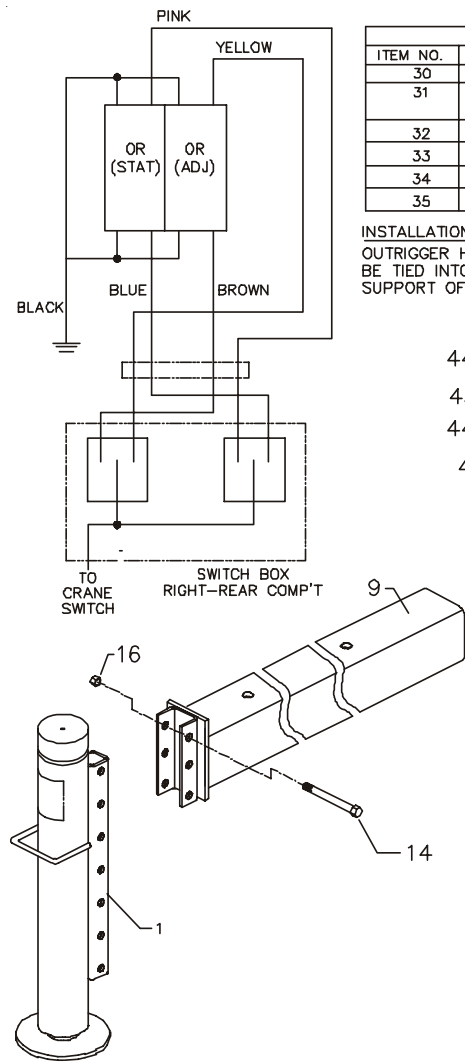

DECAL PLACEMENT	
ITEM NO.	LOCATION
30	ONE ON EACH OUTRIGGER
31	AT OR NEAR THE NORMAL OPERATING STATION
32	AT PWR DN CTRL HANDLES
33	NEAR SELECTOR VALVE
34	ON SWITCH BOX
35	ON SWITCH BOX

INSTALLATION:
OUTRIGGER HOUSING TUBE MUST BE TIED INTO THE STRUCTURAL SUPPORT OF THE CRANE.

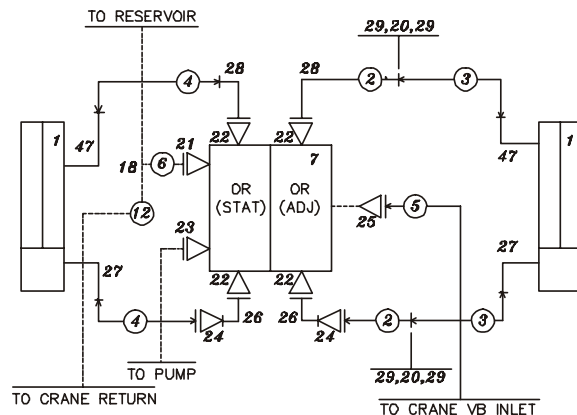
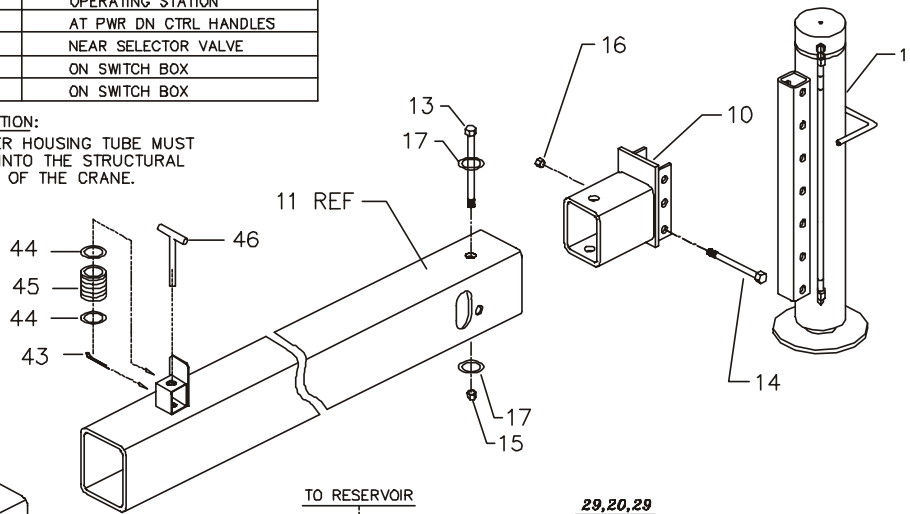

**OPTION-AUX OUTRIGGERS-MO/MD-7X5
(31712902)**

INSTALLATION NOTE

OUTRIGGER HOUSING TUBE MUST BE TIED INTO THE STRUCTURAL SUPPORT OF THE CRANE.

(Non-IMT Mechanic Service Body Application)

ITEM	PART NO.	DESCRIPTION	QTY
1.	52070138	T-PIN	1
2.	52712889	ARM-ADJUSTABLE	1
3.	52712890	ARM-STATIONARY	1
4.	52703353	LEG	2
5.	60010351	SPRING	1
6.	71731361	T-PIN-QUICK RELEASE	2
7.	72060107	CAP SCR 1/2-13X8 HHGR5	1
8.	72062080	NUT 1/2-13 LOCK	1
9.	72063007	WASHER 5/8 WRT	1
10.	72066185	COTTER PIN 1/16X1	1
11.	52712734	OUTRIGGER HOUSING 7X5	1

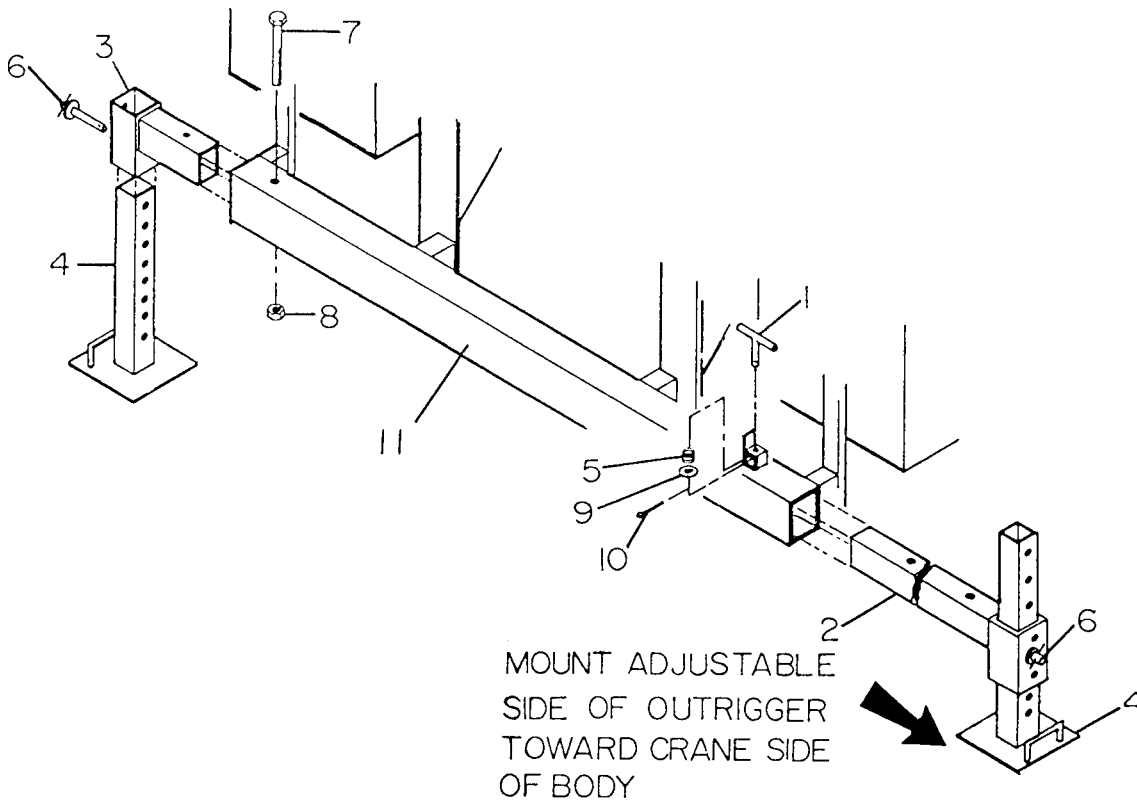

CYLINDER-PWR DN (3B205010)

ITEM	PART NO.	DESCRIPTION	QTY
1.	4B205010	CASE ASY	1
2.	4G048870	ROD ASY	1
3.	72053763	ELL #8MSTR #8MJIC 90°	1
4.	73054681	CHECK VALVE	1
5.	5P288970	PORT TUBE	1
6.	6HD35025	HEAD	1
7.	6ID35125	PISTON	1
8.	7Q072338	O-RING	1REF
9.	7Q10P338	BACKUP RING	1REF
10.	7T2NX427	WEAR RING	2REF
11.	7R546025	U-CUP SEAL	1REF
12.	7R14P025	ROD WIPER	1REF
13.	7T2N4035	PISTON RING	2REF
14.	7T61N125	NYLON LOCK RING	1REF
15.	7T66P035	PISTON SEAL	1REF
16.	6A025025	WAFER LOCK	1REF
17.	7Q072151	O-RING	1REF
18.	9D142020	SEAL KIT (INCL. 8-17)	1
19.	6C015025	STOP TUBE	1

NOTE

IT IS RECOMMENDED THAT ALL COMPONENTS OF THE SEAL KIT BE REPLACED WHENEVER THE CYLINDER IS DISASSEMBLED. THIS WILL REDUCE FUTURE DOWNTIME.

APPLY "LUBRIPLATE #630-2" MEDIUM HEAVY, MULTI-PURPOSE LUBRICANT OR EQUIVALENT TO ALL PISTON AND HEAD GLANDS, LOCK RING AND ROD THREADS BEFORE ASSEMBLY.

USE "NEVER-SEEZ" OR EQUIVALENT BETWEEN THE HEAD AND THE CASE WHEN ASSEMBLING THE CYLINDER.

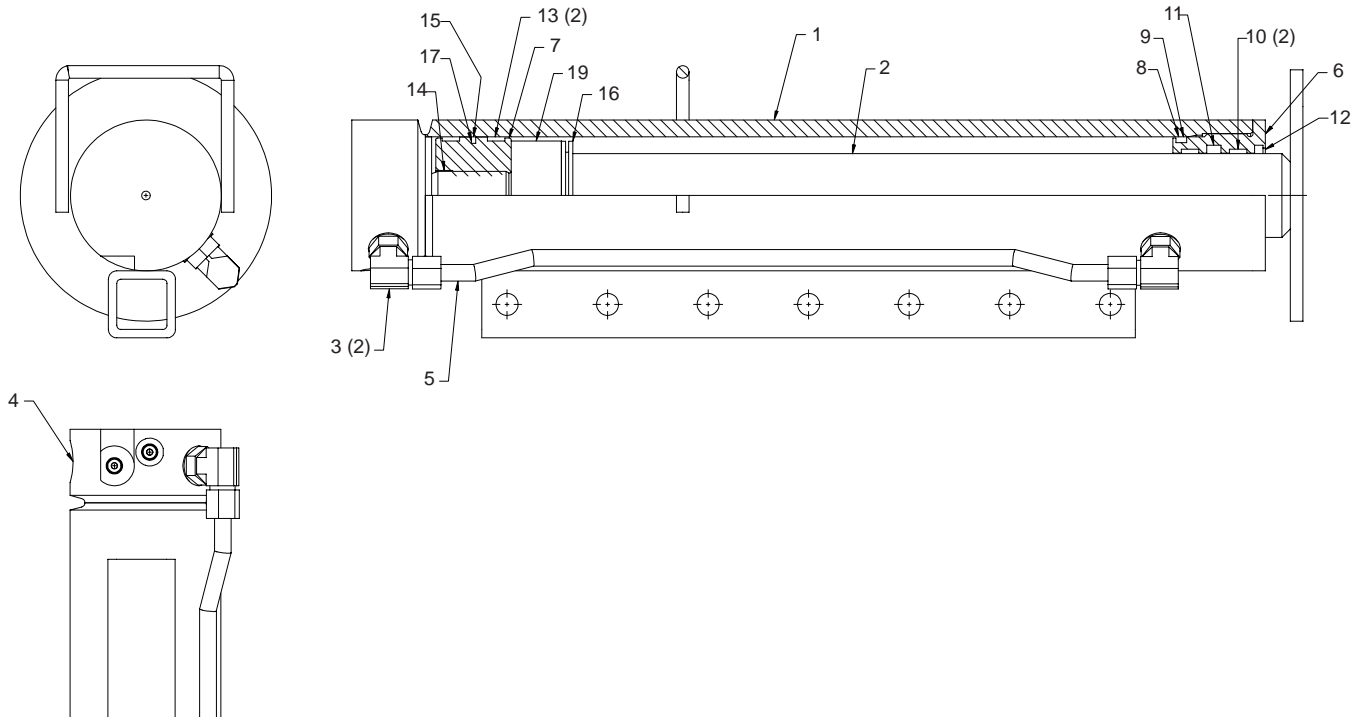

CYLINDER-PWR OUT (3B142860)

1.	4B142860	CASE ASM	1
2.	4G142860	ROD ASM	1
3.	6C125007	STOP TUBE	1
4.	6H012007	HEAD	1
5.	6I012050	PISTON	1
6.	9B050608	SEAL KIT (INCL:7-13)	1
7.	7Q072021	O-RING (PART OF 6)	1REF
8.	7Q072214	O-RING (PART OF 6)	1REF
9.	7Q10P214	BACK-UP RING (PART OF 6)	1REF
10.	7R100750	ROD SEAL (PART OF 6)	1REF
11.	7R13P007	ROD WIPER (PART OF 6)	1REF
12.	7T66P012	PISTON SEAL (PART OF 6)	1REF
13.	72066029	RETAINING RING	1

NOTE

IT IS RECOMMENDED THAT ALL COMPONENTS OF THE SEAL KIT BE REPLACED WHENEVER THE CYLINDER IS DISASSEMBLED. THIS WILL REDUCE FUTURE DOWNTIME.

APPLY "LUBRIPLATE #630-2" MEDIUM HEAVY, MULTI-PURPOSE LUBRICANT OR EQUIVALENT TO ALL PISTON AND HEAD GLANDS, LOCK RING AND ROD THREADS BEFORE ASSEMBLY.

USE "NEVER-SEEZ" OR EQUIVALENT BETWEEN THE HEAD AND THE CASE WHEN ASSEMBLING THE CYLINDER. KEEP AWAY FROM ALL SEALS.

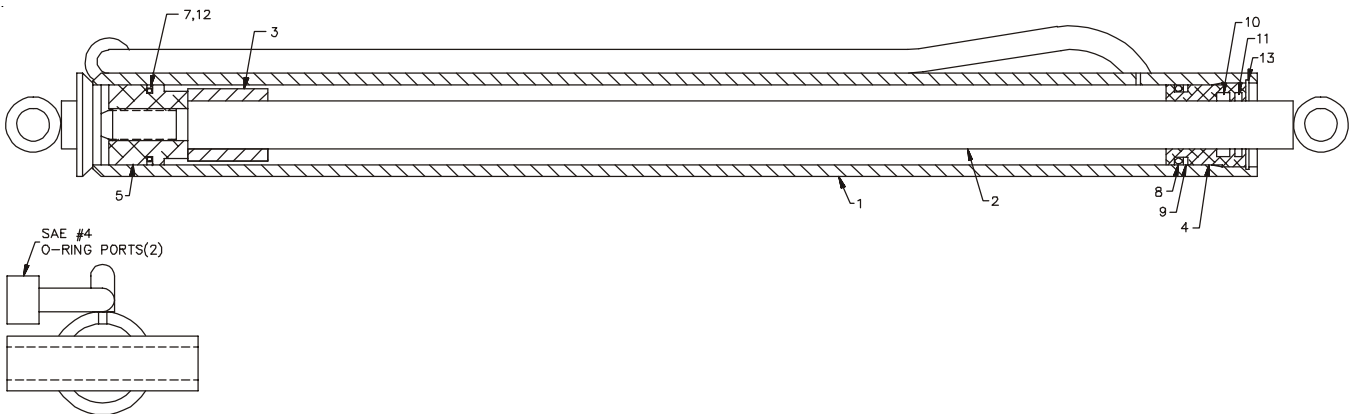

VALVEBANK ASM-2 SECTION (51705983)

EFFECTIVE PREVIOUS TO 1-1-00:

1. 51731580	LEVER ASM	2
2. 7Q072017	O-RING SM	3
3. 7Q072018	O-RING MED	6
4. 7Q072021	O-RING LG	3
5. 73054490	TANDEM VALVE SECTION	2
6. 73540010	END COVER RH	1
7. 73731763	POWER BEYOND ADAPTER	1
8. 94731590	TIE ROD KIT (2 SECT)	1
9. 73054488	END COVER-LH	1
10. 7Q072114	O-RING	4

EFFECTIVE FROM 1-1-00:

1. 73540073	LEVER ASM	2
2. 7Q072017	O-RING SM	3
3. 7Q072018	O-RING MED	6
4. 7Q072021	O-RING LG	3
5. 73540074	VALVE SECTION 4-WAY	2
6. 73540075	END COVER RH	1
7. 73540076	POWER BEYOND ADAPTER	1
8. 73540078	TIE ROD KIT (2 SECT)	1
9. 73540077	END COVER-LH	1
10. 7Q072114	O-RING	4

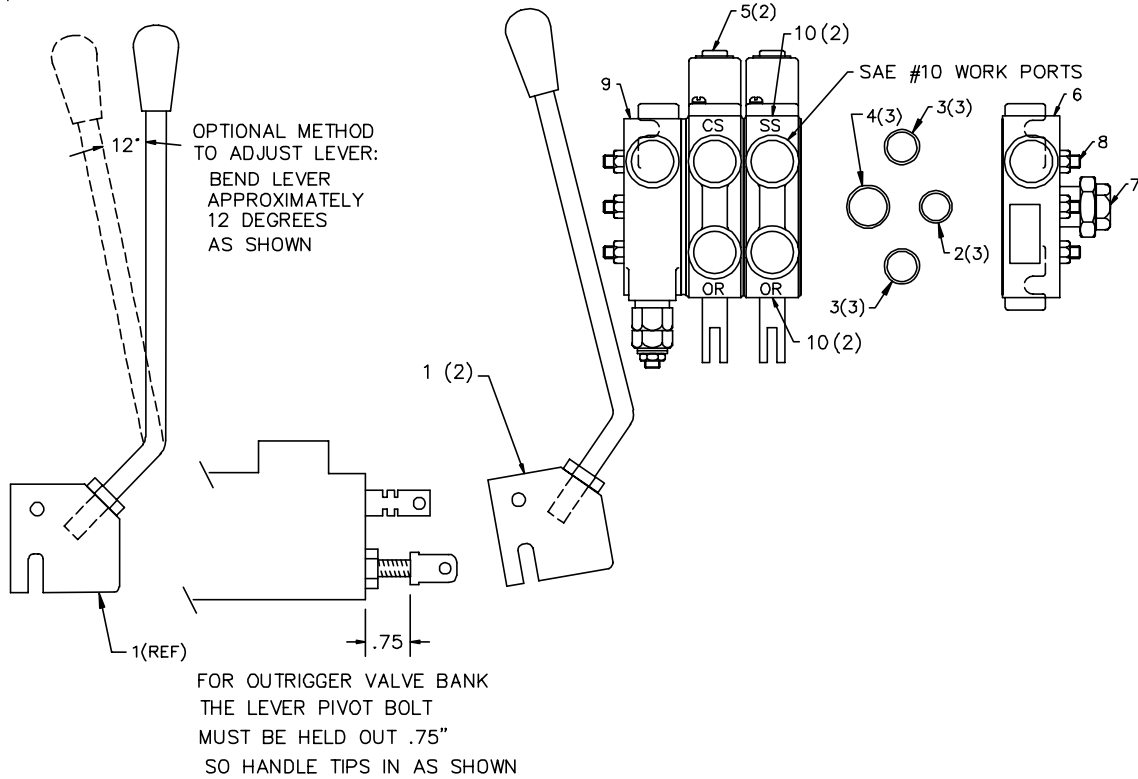

51714813.01.REV A 20031017

VALVEBANK ASM-2 SECTION (51714813)

1. 51705983	VALVEBANK, 2 SECTION	1
2. 72053763	ELBOW #8MSTR #8MJIC 90°	1
3. 72532358	ADPTR #8MSTR #8MJIC	1
4. 72532358	ADPTR #8MSTR #8MJIC	1
5. 72532792	ADPTR #8MSTR #4MJIC	4

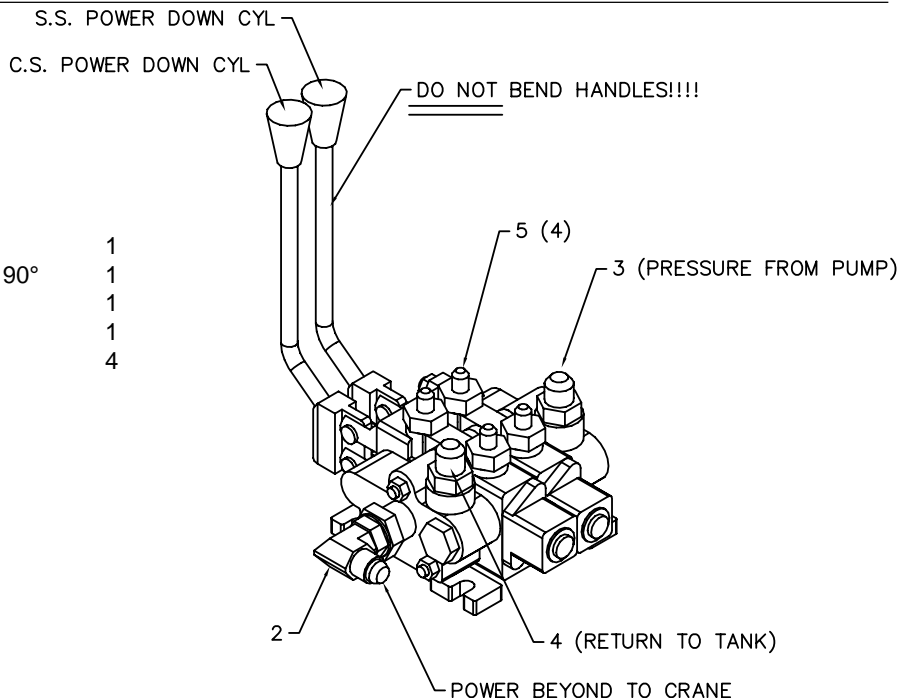

VALVEBANK ASM-3 SECTION OR - PO/PD (51714812)

- | | | | |
|----|----------|--|---|
| 1. | 51705984 | VALVEBANK - 3 SECTION | 1 |
| 2. | 72053763 | ELBOW #8MSTR #8MJIC 90°
(WAS 72053764 - ELBOW #10MSTR #8MJIC 90°) | 1 |
| 3. | 72532358 | ADPTR-#8MSTR #8MJIC | 1 |
| 4. | 72532358 | ADPTR-#8MSTR #8MJIC
(WAS 72532359-ADPTR #10MSTR #8MJIC) | 1 |
| 5. | 72532792 | ADPTR #8MSTR #4MJIC
(WAS 72533589-ADPTR #10MSTR #4MJIC) | 6 |

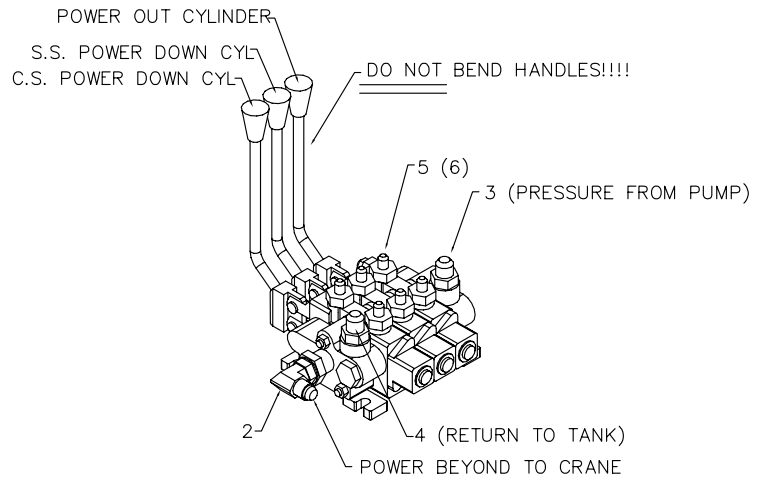

CAP FITTINGS PRIOR TO SHIPPING AND HANDLING

51705984.01.20001206

VALVEBANK ASM-3 SECTION (51705984)

EFFECTIVE PREVIOUS TO 1-1-00:

- | | | | |
|-----|----------|------------------------|---|
| 1. | 51731580 | HANDLE ASM (NOT SHOWN) | 3 |
| 2. | 7Q072017 | O-RING SM | 4 |
| 3. | 7Q072018 | O-RING MED | 8 |
| 4. | 7Q072021 | O-RING LG | 4 |
| 5. | 73054490 | TANDEM VALVE SECTION | 3 |
| 6. | 73540010 | END COVER RH | 1 |
| 7. | 73731763 | POWER BEYOND ADAPTER | 1 |
| 8. | 94731764 | TIE ROD KIT | 1 |
| 9. | 73054488 | END COVER LH | 1 |
| 10. | 7Q072114 | O-RING | 6 |

EFFECTIVE FROM 1-1-00:

- | | | | |
|-----|----------|----------------------|---|
| 1. | 73540073 | HANDLE ASM | 3 |
| 2. | 7Q072017 | O-RING SM | 4 |
| 3. | 7Q072018 | O-RING MED | 8 |
| 4. | 7Q072021 | O-RING LG | 4 |
| 5. | 73540074 | VALVE SECTION | 3 |
| 6. | 73540075 | END COVER RH | 1 |
| 7. | 73540076 | POWER BEYOND ADAPTER | 1 |
| 8. | 73540079 | TIE ROD KIT | 1 |
| 9. | 73540077 | END COVER LH | 1 |
| 10. | 7Q072114 | O-RING | 6 |

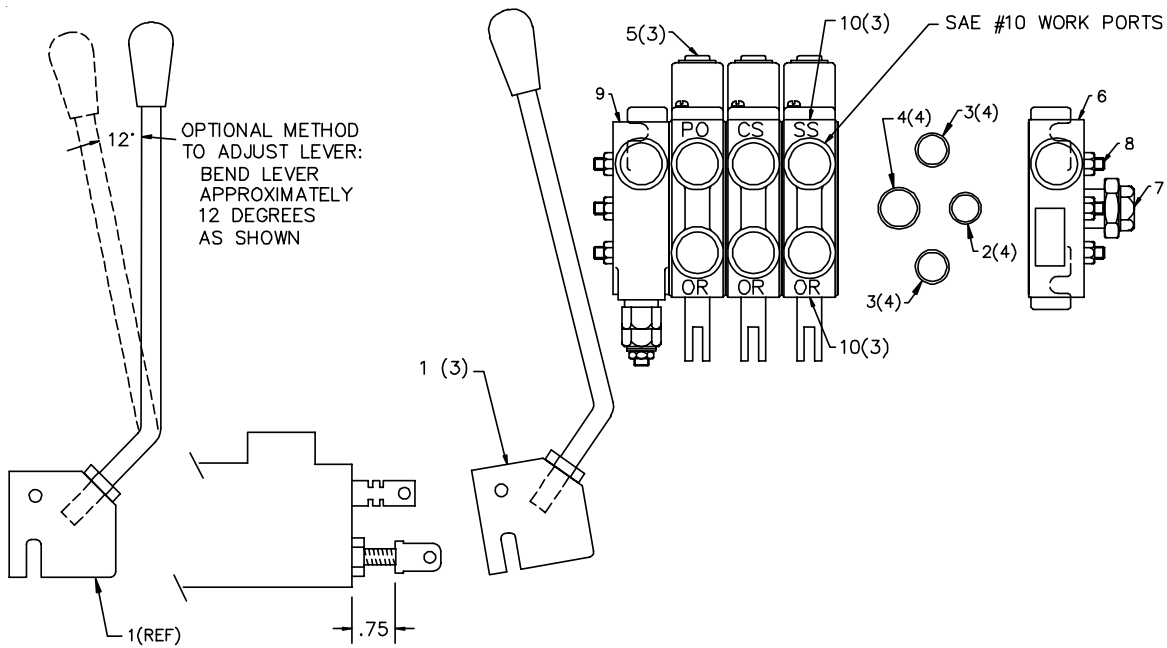

FOR OUTRIGGER VALVE BANK
THE LEVER PIVOT BOLT
MUST BE HELD OUT .75"
SO HANDLE TIPS IN AS SHOWN

CONTROL KIT-RADIO RMT (90718833)
(EFFECTIVE 8/04)

1.	70034439	LOCK WIRE, LEAD SEAL, 8"	2
2.	70733921	RECEIVER, RADIO REMOTE	1
4.	70733883	TRANSMITTER, RADIO REMOTE	1
6.	60125959	BRACKET, TETHER CONNECTOR	1
7.	72066340	RIVET, POPAL. 1/8X3/8 GRIP	1
8.	72601846	CAP SCR, SS 1/4-20 X 1-1/4 HH	2
9.	72062194	NUT, SS 1/4-20 NYLOC	2
10.	99903628	INSTRUCTIONAL DWG, RADIO REMOTE	1
11.	93719637	KIT, SWITCH, 2-SPEED	1
13.	99903629	INSTALLATION DWG, RADIO REMOTE	1

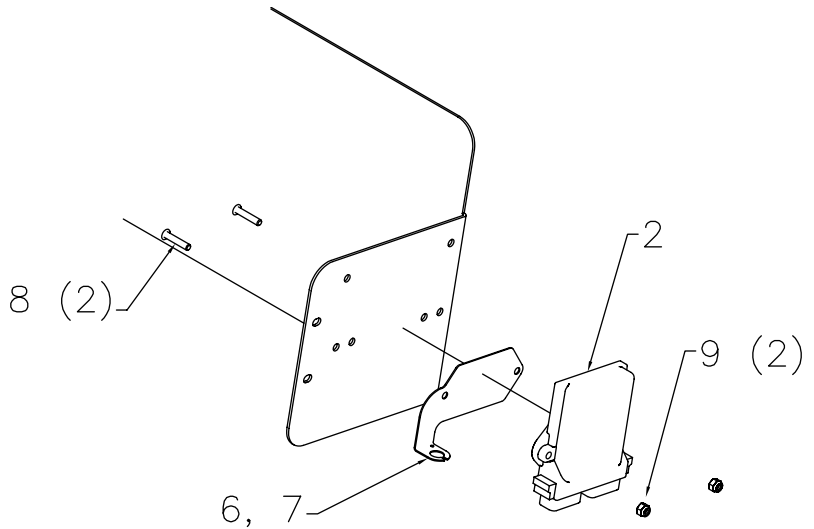
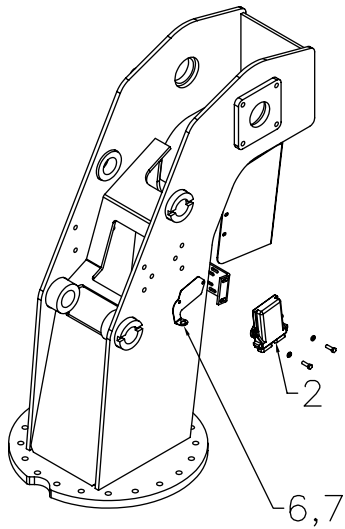

RECEIVER ASSEMBLY DETAIL

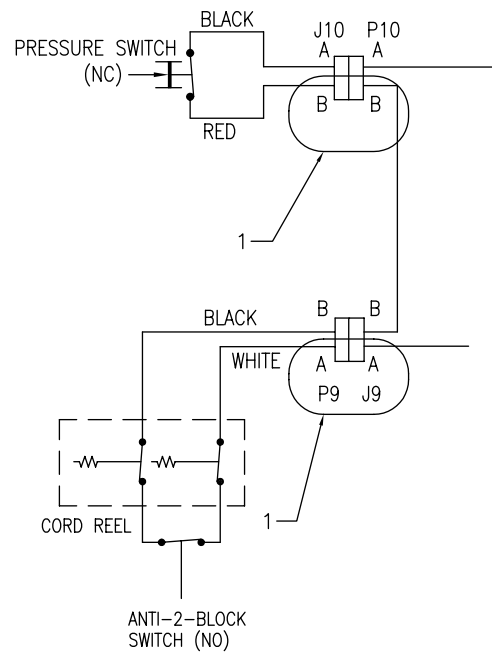
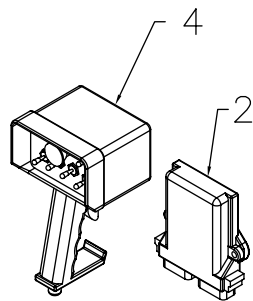

**CONTROL KIT-RADIO RMT (90715635-1)
(THROUGH 7/04)**

CONTINUED ON FOLLOWING PAGE

1.	70733354	RADIO RMT (INCL:5&6)	1
2.	72060025	CAP SCR 5/16-18X1 HHGR5	4
3.	72063050	WASHER 5/16 LOCK	4
4.	51716912	HANDLE ASM-RR B-UP (EFF 9/01)	1
	51715567	HANDLE ASM-RR BACKUP (THRU 9/01)	1
5.	73733392	RADIO RMT-RCVR (PART OF 1)	1REF
6.	73733393	RADIO RMT-XMTR (PART OF 1)	1REF
7.	70034439	LOCK WIRE LEAD SEAL 8"	2

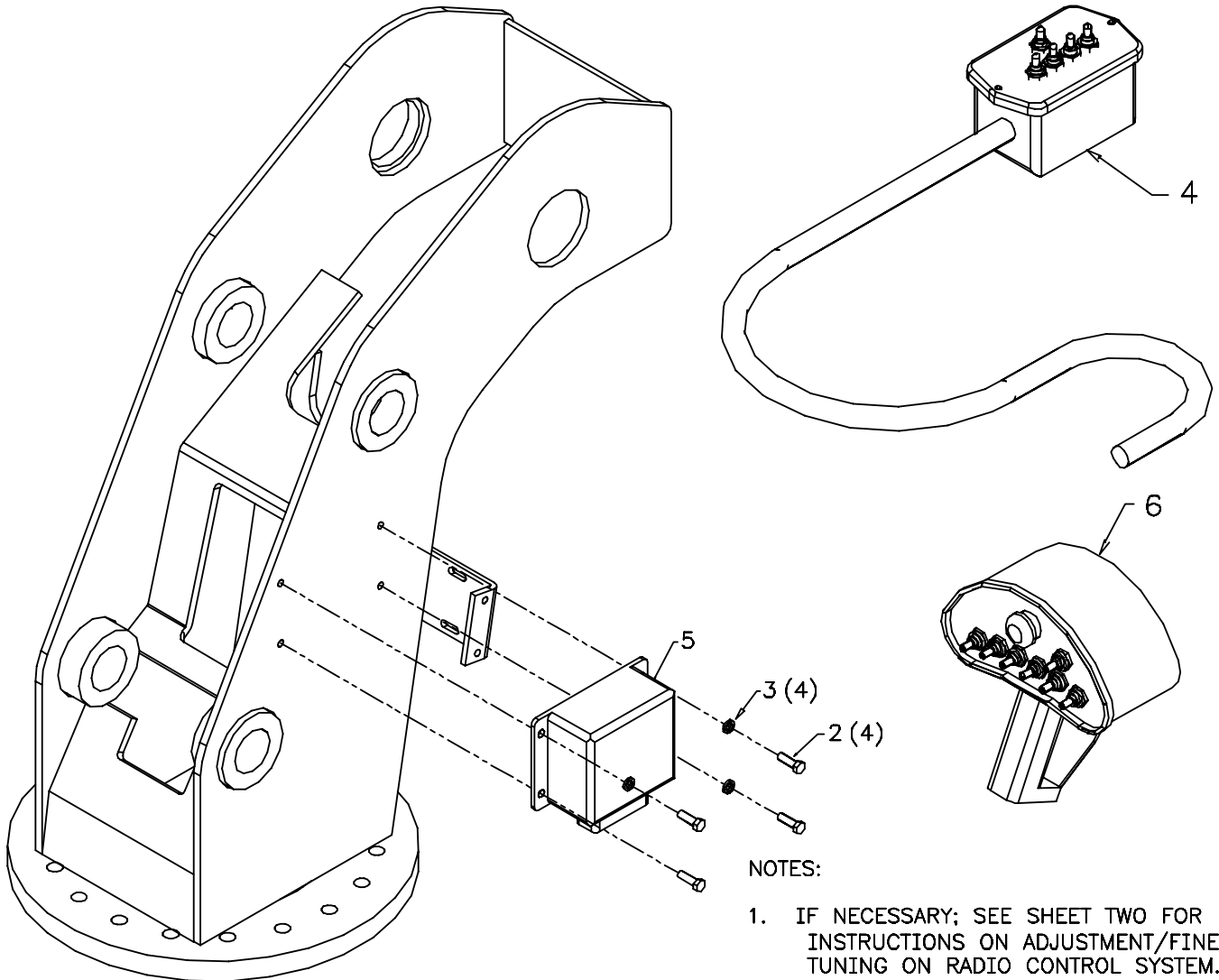

NOTES:

1. IF NECESSARY; SEE SHEET TWO FOR INSTRUCTIONS ON ADJUSTMENT/FINE TUNING ON RADIO CONTROL SYSTEM.
2. SEE SCHEMATIC (DRAWING NUMBER 99903131) FOR PLACEMENT OF ITEM NUMBER 7.

**CONTROL KIT-RADIO RMT (90715635-2)
(THROUGH 7/04)**

CONNECTOR PIN LETTER	IMT ASSIGNED FUNCTION
A1	ROT CW
A2	EXT OUT
A3	WINCH DN
A4	WINCH UP
A5	PROP VALVE +
A6	EXT IN
A7	ENGINE START
A8	RADIO GND
A9	SPEED RELAY
B1	NOT USED
B2	ROT CCW
B3	RADIO POWER
B4	KILL RELAY
B5	LOW DN
B6	NOT USED
B7	LOWER UP
B8	NOT USED
B9	NOT USED
C1	PROP VALVE -
C2	NOT USED
C3	COMPRESSOR
C4	WINCH 2 SPD
C5	NOT USED
C6	NOT USED
C7	NOT USED
C8	NOT USED
C9	NOT USED

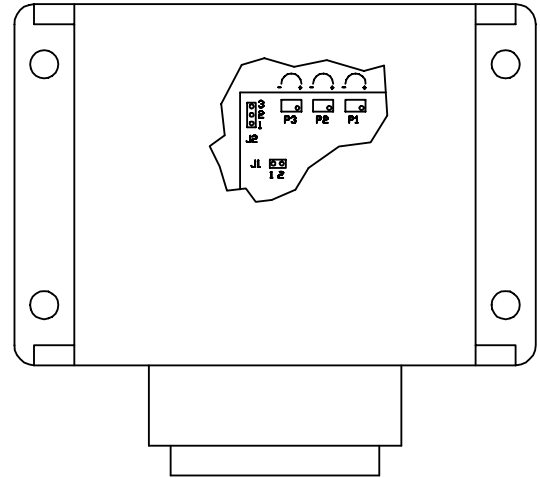
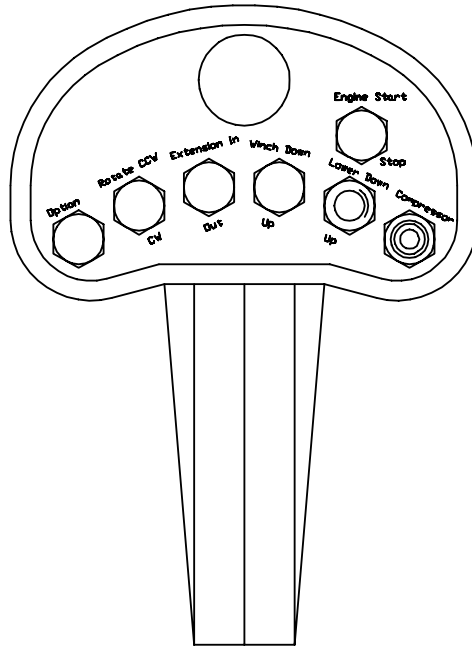

JUMPER CONNECTIONS INSIDE RECEIVER

J1: PULSE/DITHER FREQUENCY
- NO JUMPER

J2: CONTROL RANGE OF OUTPUT CURRENT (ONLY
CURRENT-CONTROL)
- PIN 2/3 CONNECTED: 0-2A

- P1: TRIMMING POTENTIOMETER FOR MAXIMUM VALUES. ON TRANSMITTER HANDLE, ENGAGE ROTATION CW OR CCW FUNCTION SWITCH AND PULL TRIGGER FULLY ON. CRANE MAY OR MAY NOT BEGIN TO MOVE AT THIS TIME DUE TO P1 INITIAL SETTING. TURN P1 POTENTIOMETER COUNTERCLOCKWISE UNTIL DESIRED MAXIMUM SPEED IS OBTAINED OR UNTIL SPEED NO LONGER CONTINUES TO INCREASE.
- P2: TRIMMING POTENTIOMETER FOR INITIAL VALUE ADJUSTMENT. ON TRANSMITTER, ENGAGE ROTATION CW OR CCW FUNCTION SWITCH. WITHOUT PULLING TRIGGER, ADJUST P2 COUNTERCLOCKWISE UNTIL CRANE BEGINS TO MOVE. AT THIS TIME, ADJUST P2 CLOCKWISE UNTIL NO MOVEMENT IS DETECTED. SLIGHTLY ENGAGE TRIGGER AND ADJUST P2 TO FINE TUNE.
- P3: TRIMMING POTENTIOMETER TO ADJUST DITHERAMPLITUDE: ADJUST CLOCKWISE OR COUNTERCLOCKWISE FOR SMOOTHNESS OF OPERATION.

HANDLE ASM - RADIO REMOTE BACKUP (51716912) (EFF. 9/01)

- | | | | |
|-----|----------|--------------------------------|----|
| 1. | 73733374 | CABLE ASM | 1 |
| 2. | 77041404 | TOGGLE SWITCH, ON-OFF-ON | 1 |
| 3. | 77041346 | TOGGLE SWITCH, (ON)-OFF-(ON) | 4 |
| 4. | 60121724 | JIC BOX | 1 |
| 5. | 77040186 | TERMINAL-FSLPON 1/4TAB | 15 |
| 6. | 60045031 | WIRE-GREEN 4" LONG | 4 |
| 7. | 77044018 | CONNECTOR 1/2 STR RLF 3/8-1/21 | 1 |
| 8. | 77044201 | NUT-ELEC 1/2 | 1 |
| 9. | 70395537 | DECAL-CONTROL | 1 |
| 10. | 77040282 | TEM-PIGBAK 16/14 GA 1/4TAB | 1 |

NOTE: UNPLUG RADIO RECEIVER BEFORE PLUGGING IN BACKUP HANDSET.

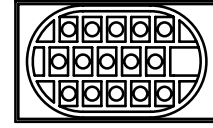
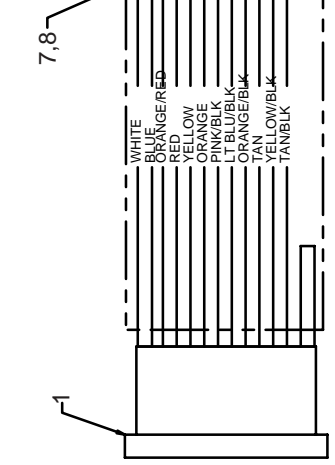
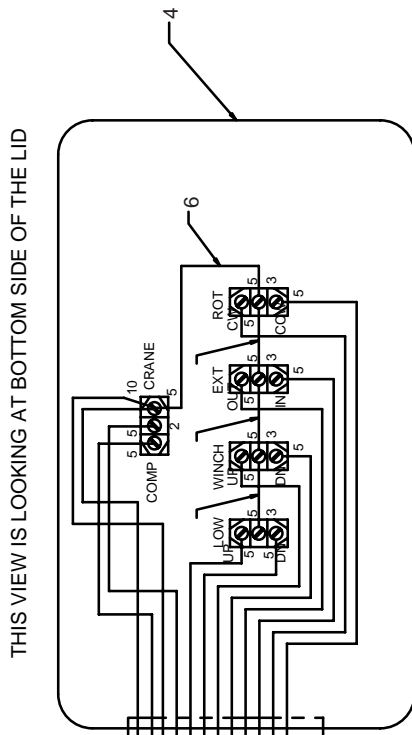

CAV.	COLOR	FUNCTION
A1	BLACK	JUMPER TO PIN B1 (GND)
A2	LT BLUE/BLACK	WINCH DOWN
A3	TAN	EXT BOOM IN
A4	ORANGE	LOWER BOOM DN
A5	TAN/BLACK	ROT CCW
B5	ORANGE/RED	PROP VALVE (*)
B1	BLACK	JUMPER TO PIN A1 (GND)
C5	YELLOW/BLACK	ROT CW
C4	YELLOW	LOWER BOOM UP
C3	ORANGE/BLACK	EXT BOOM OUT
C2	PINK/BLACK	WINCH UP
C1	RED	MAIN POWER
B2	WHITE	SOLENOID POWER
B3	BLUE	COMPRESSOR

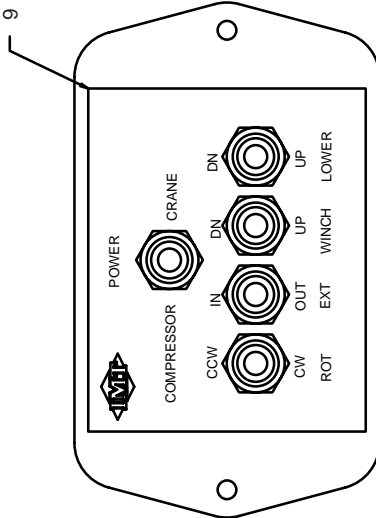

THIS VIEW IS LOOKING AT TOP SIDE OF THE LID

**HANDLE ASM-RADIO RMT (51715567)
(THRU 9/01)**

- | | | | |
|-----|----------|-------------------------|----|
| 1. | 73733374 | CABLE ASM | 1 |
| 2. | 77041345 | SWITCH-TOGGLE SGL-THRW | 1 |
| 3. | 77041346 | SWITCH-TOGGLE DBL-THRW | 4 |
| 4. | 60121724 | JIC BOX | 1 |
| 5. | 77040186 | TERMINAL 1/4FSLPON | 14 |
| 6. | 60045031 | WIRE 4" GRN | 4 |
| 7. | 77044018 | STRAIN RELIEF 1/2 | 1 |
| 8. | 77044201 | NUT 1/2 ELEC | 1 |
| 9. | 70395536 | DECAL-RMT CTRL | 1 |
| 10. | 77040282 | TERM-1/4 PIGBAC 16-14GA | 4 |

CAV	COLOR	FUNCTION
A1	BLACK	JUMPER TO PIN B1 (GND)
A2	LTBLUE/BLACK	WINCH DOWN
A3	TAN	EXT BOOM IN
A4	ORANGE	LOWER BOOM DN
A5	TAN/BLACK	ROT CCW
B5	ORANGE/RED	PROP VALVE (+)
B1	BLACK	JUMPER TO PIN A1 (GND)
C6	YELLOW/BLACK	ROT CW
C4	YELLOW	LOWER BOOM UP
C3	ORANGE/BLACK	EXT BOOM OUT
C2	PINK/BLACK	WINCH UP
C1	RED	MAIN POWER
B2	WHITE	SOLENOID POWER
B3	BLUE	COMPRESSOR

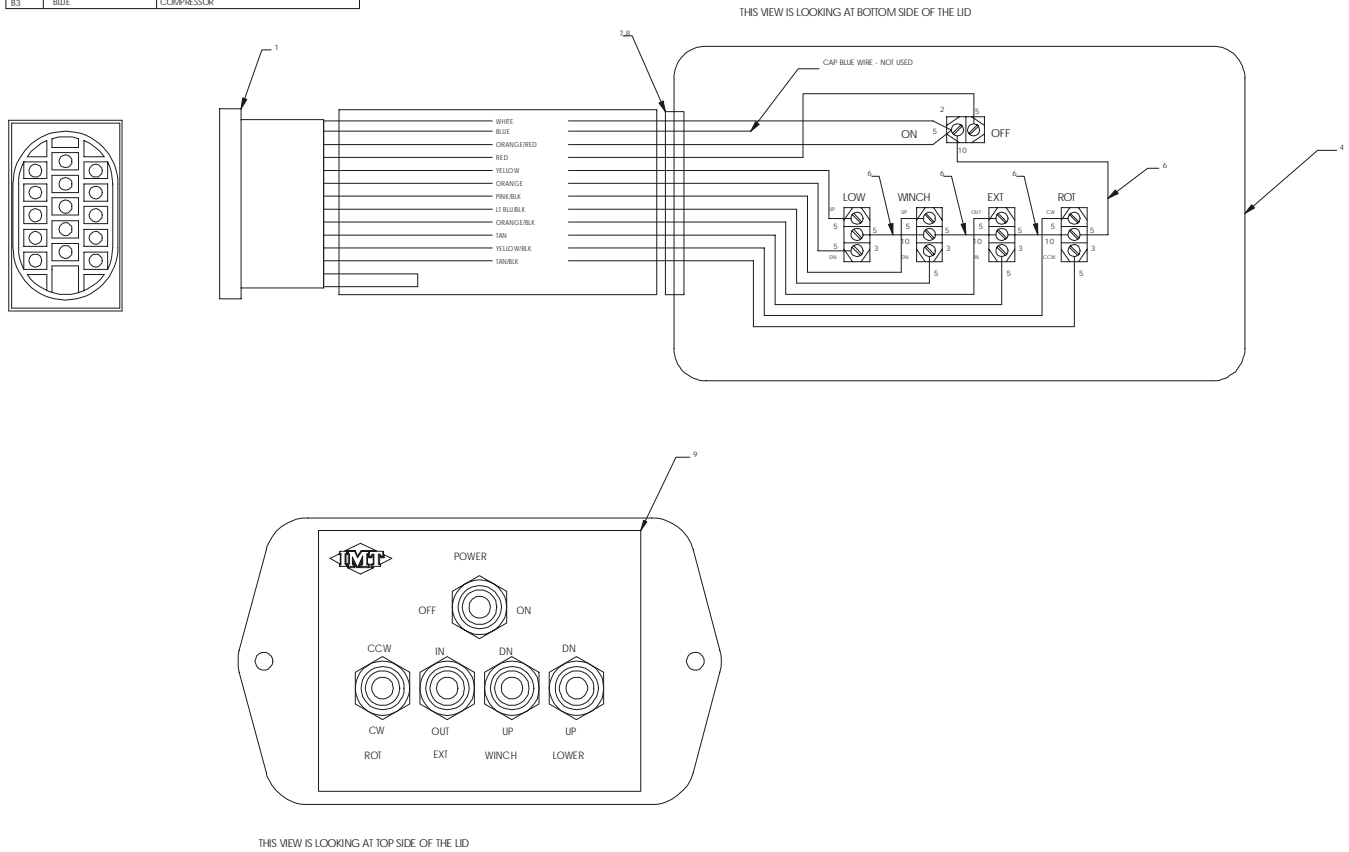

CABLE ASM-RADIO RMT BACKUP (73733374)

CAV.	COLOR	GA.	FUNCTION-TELESCOPIC	LABELING	FUNCTION-ARTICULATING
*A1	BLACK	16	RADIO GROUND	RADIO GND	JUMPER TO PIN B1 (GND)
A2	LT BLU/BLK	16	WINCH DOWN	WIN DN	INNER BOOM DOWN
A4	ORANGE	16	LOWER DOWN	LOW DN	OUTER BOOM DOWN
A3	TAN	16	EXTENSION IN	EXT IN	ROT CCW
A5	TAN/BLK	16	ROTATE CCW	ROT CCW	EXT BOOM IN
B5	ORANGE/RED	16	PROP VALVE +	PROP VALVE +	PROP VALVE (+)
*B1	BLACK	16	PROP GROUND	PROP GND	JUMPER TO PIN A1 (GND)
C5	YELLOW/BLK	16	ROTATE CW	ROT CW	EXT BOOM OUT
C3	ORANGE/BLK	16	EXTENSION OUT	EXT OUT	ROT CW
C4	YELLOW	16	LOWER UP	LOW UP	OUTER BOOM UP
C2	PINK/BLACK	16	WINCH UP	WIN UP	INNER BOOM UP
C1	RED	16	RADIO POWER	RAD PWR	MAIN POWER
B2	WHITE	16	SOLENOID POWER	SOL PWR	SOLENOID POWER
B3	BLUE	16	COMPRESSOR	COMP	COMPRESSOR ON

* CAVITIES A1 AND B1 ARE JUMPED.

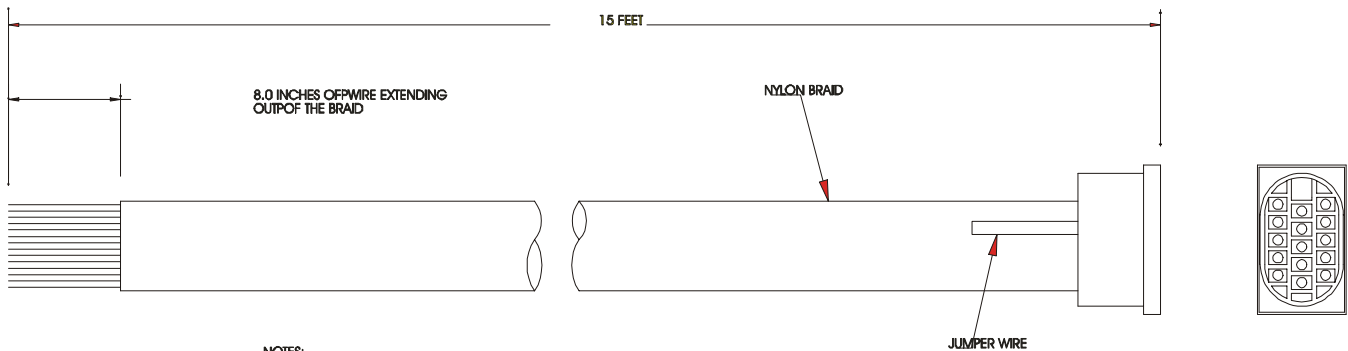

NOTES:

1. BRAID SHOULD BE WITHIN 1" TO THE BACK OF THE RECEPTACLE.
2. ALL WIRE TO BE GXL
3. LABELING SHALL APPEAR ON WIRES EVERY 2" TYPICAL.
4. CONNECTOR: METRI-PACK (12161187)
 TERMINAL: METRI-PACK (12124977)
 CABLE SEALS: METRI-PACK (12015323)
 CAVITY PLUG: METRI-PACK (12010300)

WIRE SPECIFICATIONS			
PART #	SIZE (AWG)	# OF STRANDS	INSULATION THICKNESS
GXL16	16	19/29	.023 MILS-NOM.
- HEAT RESISTANCE IN ACCORDANCE WITH SAE J-1128 - TEMPERATURE RANGE: -51 C TO +125 C - MEETS FORD SPEC (M1L-658) & CHRYSLER (MS-8900)			

HYD KIT-RADIO RMT (91715633-1)

CONTINUED ON FOLLOWING PAGE

- | | | | |
|-----|----------|-----------------------------------|--------|
| 1. | 73733932 | VALVEBANK(INCL:10,11,15,16,20,21) | 1 |
| | | (WAS 73733383) | |
| 2. | 72060005 | CAP SCR 1/4-20X1-1/4 HHGR5 | 4 |
| 3. | 72062104 | NUT 1/4-20 LOCK | 4 |
| 4. | 72063001 | WASHER 1/4 WRT | 4 |
| 5. | 51715066 | HOSE KIT (INCL:6-9,22) | 1 |
| 6. | 51395555 | HOSE ASM FF .38X34 #8#8 | 1REF |
| 7. | 51395309 | HOSE ASM FF .38X36 #8#8 | 2REF |
| 8. | 51395307 | HOSE ASM FF .38X23 #6#8 | 2REF |
| 9. | 51395306 | HOSE ASM FJ .25X48 #6#6 | 2REF |
| 10. | 72053763 | ELBOW #8MSTR #8MJIC 90° | 3REF |
| 11. | 72532666 | ELBOW #8MSTR #8MJIC 90° | 2REF |
| 12. | 72053764 | ELBOW #10MSTR #8MJIC 90° | 1 |
| 13. | 72532358 | ADAPTER #8MSTR #8MJIC | 2,1REF |
| 14. | 72533613 | ADAPTER #10MSTR #6MJIC | 2 |
| 15. | 72532700 | ELBOW #6MSTR #6MJIC XLG | 2REF |
| 16. | 72053761 | ELBOW #8MSTR #6MJIC 90° | 2REF |
| 17. | 72532670 | ELBOW #8MJIC #8FJIC 45° | 2 |
| 18. | 72532658 | ELBOW #8MJIC #8FJIC SWVL | 1 |
| 19. | 72532359 | ADAPTER #10MSTR #8MJIC | 1 |
| 20. | 72533052 | ADAPTER #8MSTR #6FSTR | 3REF |
| 21. | 72053760 | ELBOW #6MSTR #6MJIC 90° | 1REF |
| 22. | 51395556 | HOSE ASM FF .38X32 #8#8 | 1REF |
| 23. | 72532357 | ADAPTER #6MSTR #8MJIC | 2 |

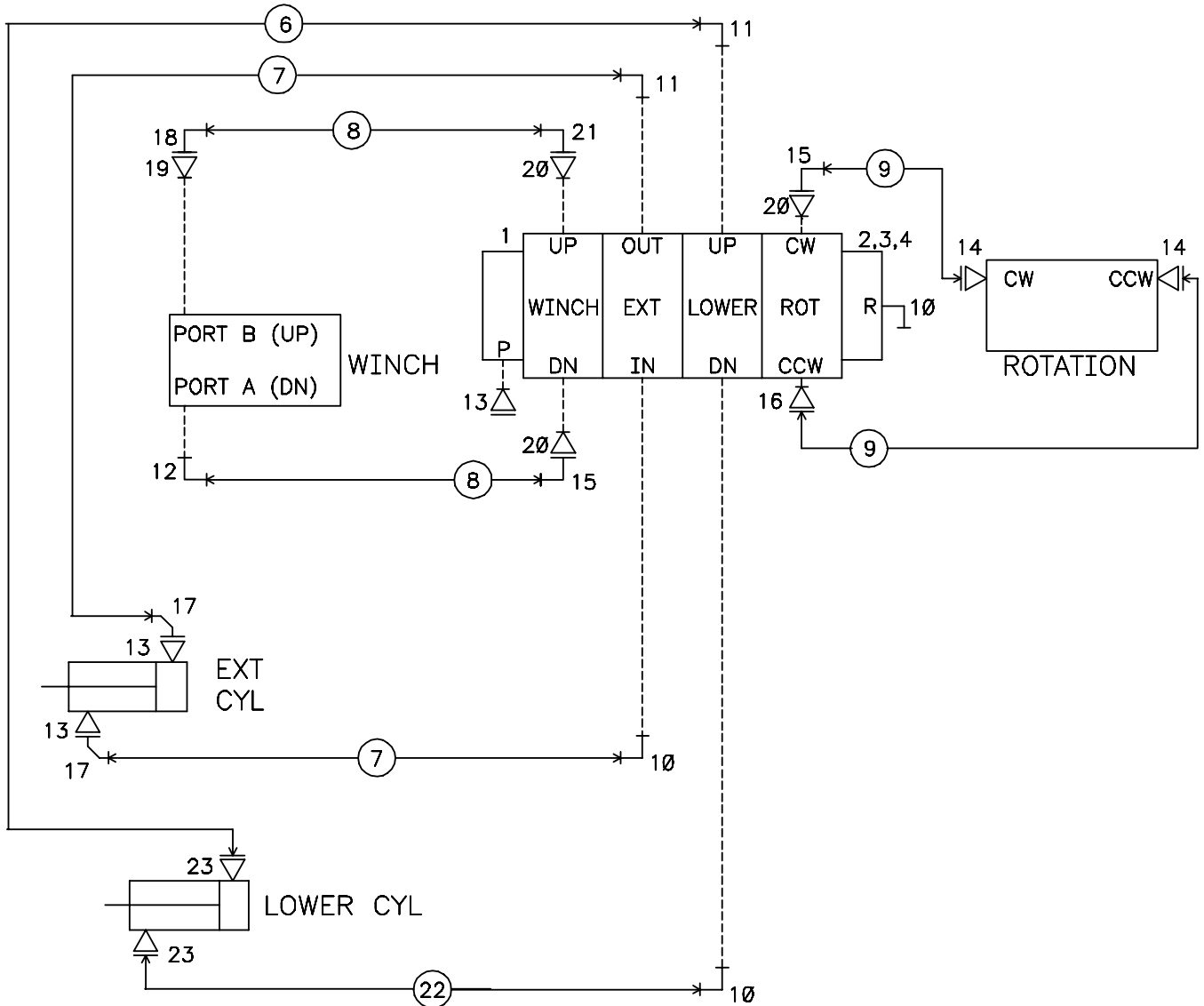

HYD KIT-RADIO RMT (91715633-2)

CONTINUED ON FOLLOWING PAGE

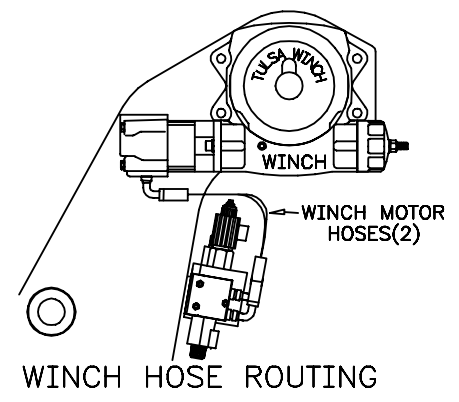
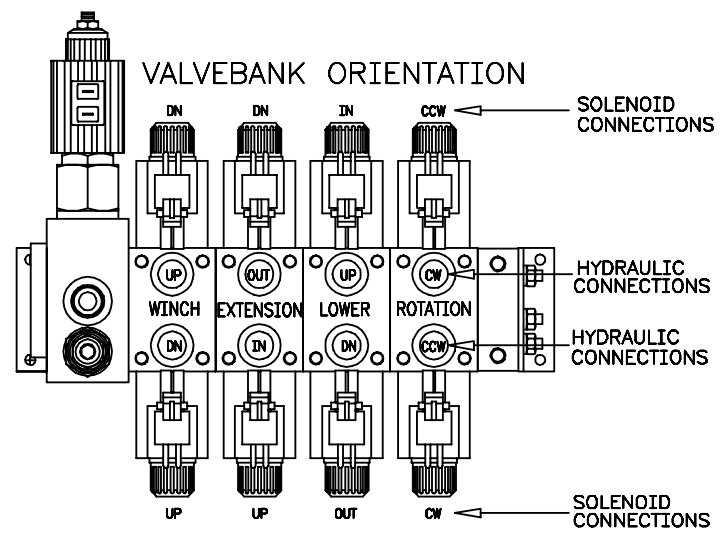
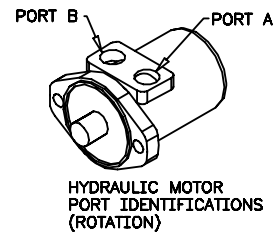
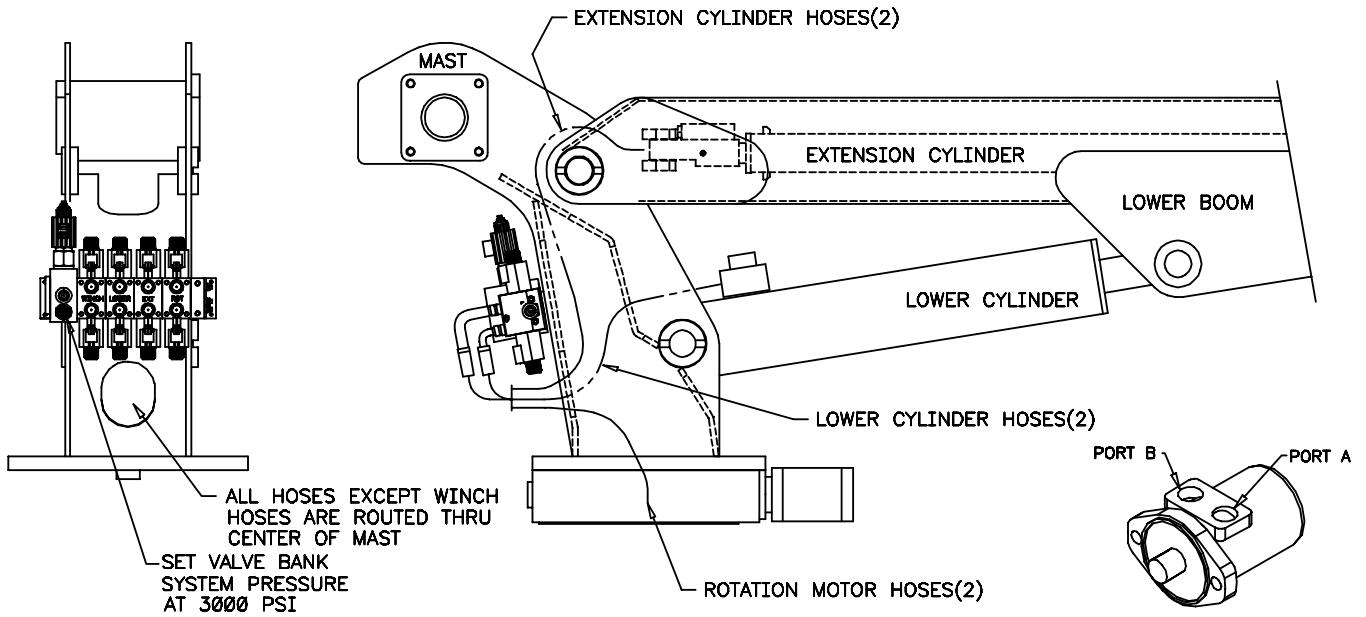

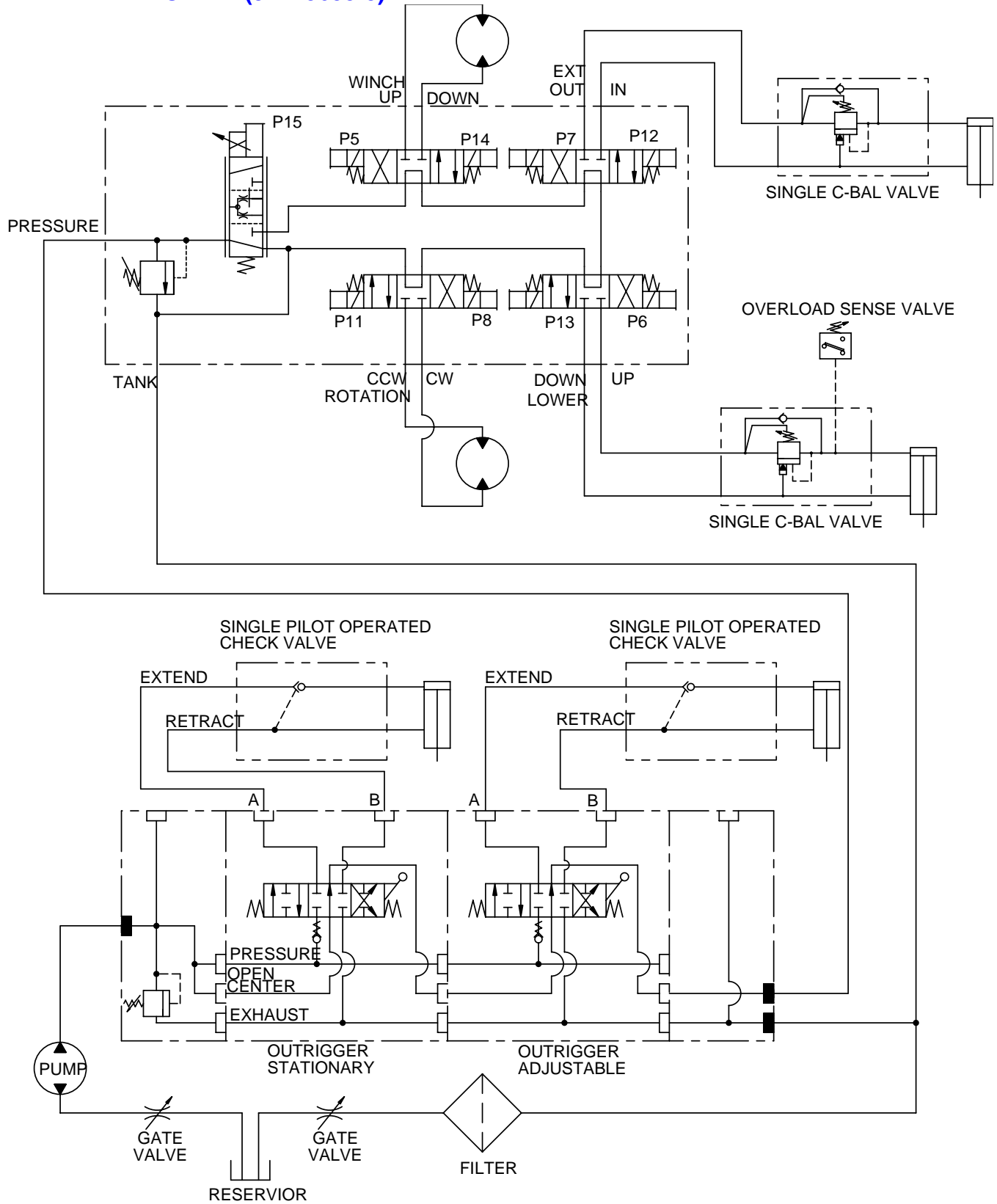

VALVEBANK-4 SECTION (73733383)
(THROUGH 8-04)

1.	73540028	BLOCK-INLET	1
2.	73540027	ENDCAP	1
3.	73054934	VALVE-PROPL FLOW CTRL	1
	77041556	PROPL VALVE-COIL ONLY	REF
4.	73054935	VALVE-RELIEF	1
5.	73540044	VALVE SECTION	4
	77041518	COIL-SOLENOID	REF
6.	7Q072013	O-RING	10
7.	72533477	PLUG 7/16STR HOLHEX	1
8.	70145829	EXPANDER PLUG	4
9.	60119363	ROD 1/4-20X12-1/2	2
10.	60119354	ROD 1/4-20X10-9/16	1
11.	72062000	NUT 1/4-20 HEX	5

12.	72063047	WASHER #10 LOCK	5
13.	77044574	CONNECTOR	9
14.	77044550	TERMINAL-FEM 18-20GA	18
15.	70394069	CABLE SEAL	2
16.	70145830	MTG BRACKET	2
20.	77044594	CABLE SEAL	16
21.	70733351	CABLE ASM	1
22.	72053763	ELBOW #8MSTR #8MJIC 90°	3
23.	72532666	ELBOW #8MSTR #8MJIC 90°	2
24.	72533603	PLUG 9/16STR HOLHEX	1
25.	72533052	ADAPTER #8MSTR #6FSTR	3
26.	72532700	ELBOW #6MSTR #6MJIC XLG	2
27.	72053760	ELBOW #6MSTR #6MJIC 90°	1
28.	72053761	ELBOW #8MSTR #6MJIC 90°	1
29.	72532356	ADAPTER #8MSTR #8MJIC	1
	70733875	NUT, PLASTIC, WITH O-RING SEAL (FOR USE ON VALVEBANK COIL)	REF

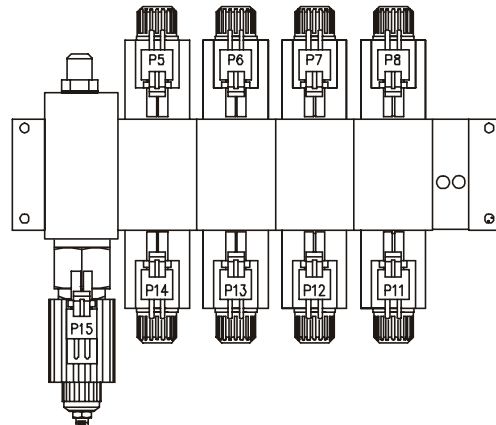
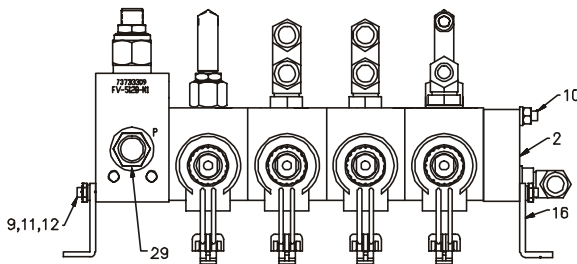
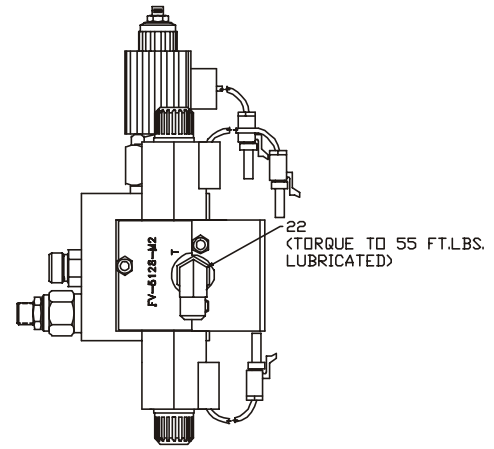
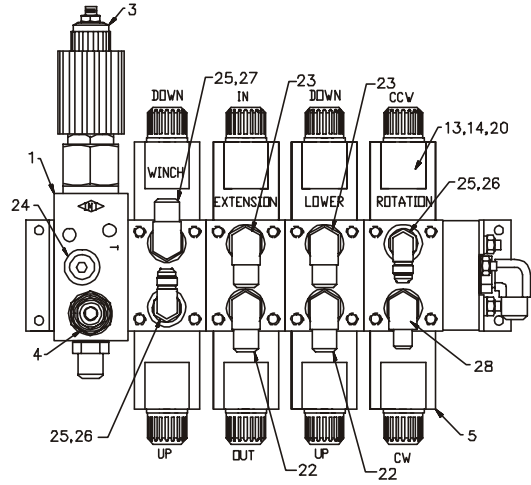
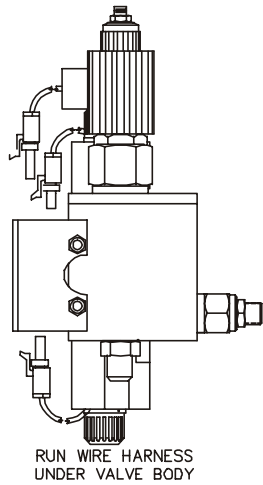
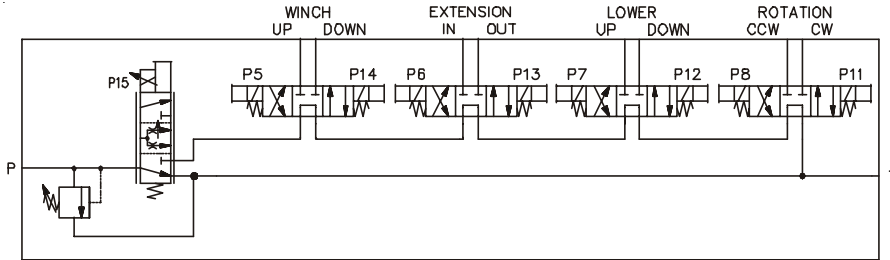

VALVEBANK-4 SECTION (73733932)
(EFFECTIVE 8-04)

1.	73540028	BLOCK-INLET	1
2.	73540027	ENDCAP	1
3.	73054934	VALVE-PROPL FLOW CTRL	1
	77041556	PROPL VALVE-COIL ONLY	REF
4.	73054935	VALVE-RELIEF	1
5.	73540044	VALVE SECTION	4
	77041518	COIL-SOLENOID	REF
6.	7Q072013	O-RING	10
7.	72533477	PLUG 7/16STR HOLHEX	1
8.	70145829	EXPANDER PLUG	4
9.	60119363	ROD 1/4-20X12-1/2	2
10.	60119364	ROD 1/4-20X10-9/16	1
11.	72062000	NUT 1/4-20 HEX	5

12.	72063047	WASHER #10 LOCK	5
13.	77044574	CONNECTOR	9
14.	77044550	TERMINAL-FEM 18-20GA	18
15.	70394069	CABLE SEAL	2
16.	70145830	MTG BRACKET	2
20.	77044594	CABLE SEAL	16
21.	77441101	CABLE ASM	1
22.	72053763	ELBOW #8MSTR #8MJIC 90°	3
23.	72532666	ELBOW #8MSTR #8MJIC 90°	2
24.	72533603	PLUG 9/16STR HOLHEX	1
25.	72533052	ADAPTER #8MSTR #6FSTR	3
26.	72532700	ELBOW #6MSTR #6MJIC XLG	2
27.	72053760	ELBOW #6MSTR #6MJIC 90°	1
28.	72053761	ELBOW #8MSTR #6MJIC 90°	1
29.	72532358	ADAPTER #8MSTR #8MJIC	1
	70733875	NUT, PLASTIC, WITH O-RING SEAL (FOR USE ON VALVEBANK COIL)	REF

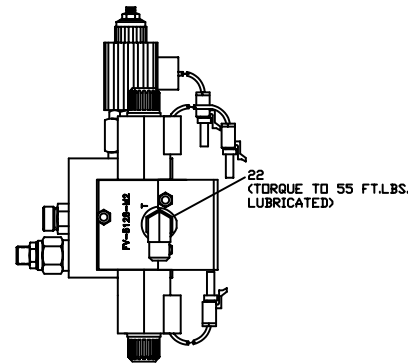
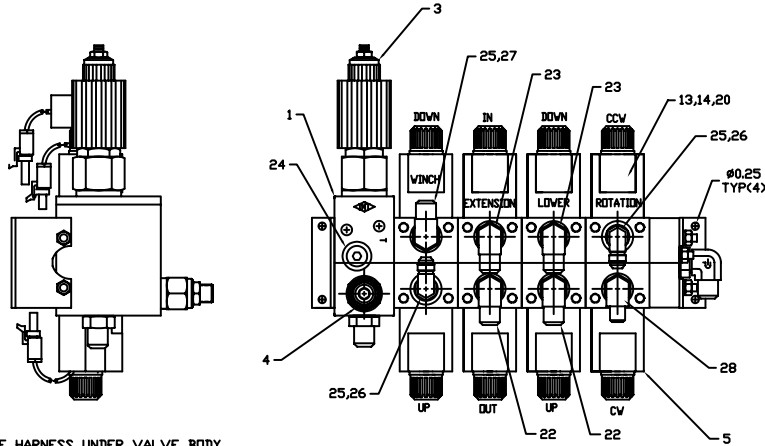

RUN WIRE HARNESS UNDER VALVE BODY

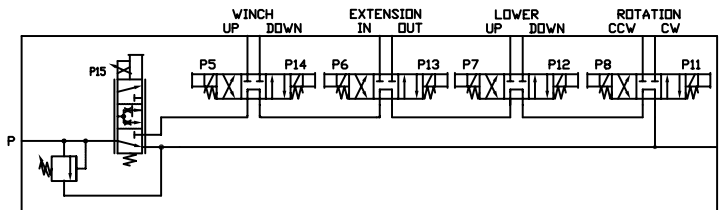
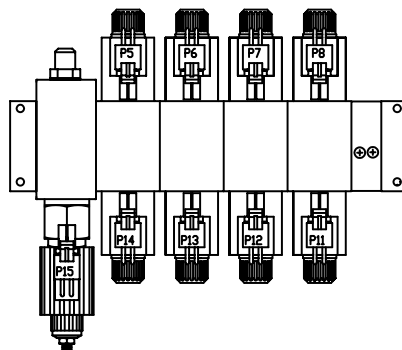
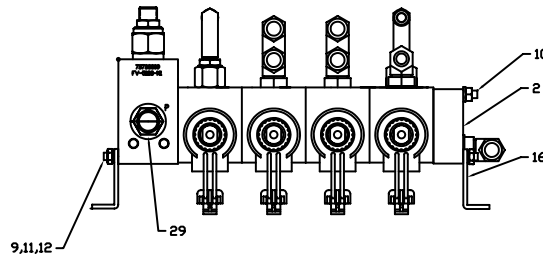

WIRING HARNESS, RADIO REMOTE (77441101-1) (EFFECTIVE 8/04)

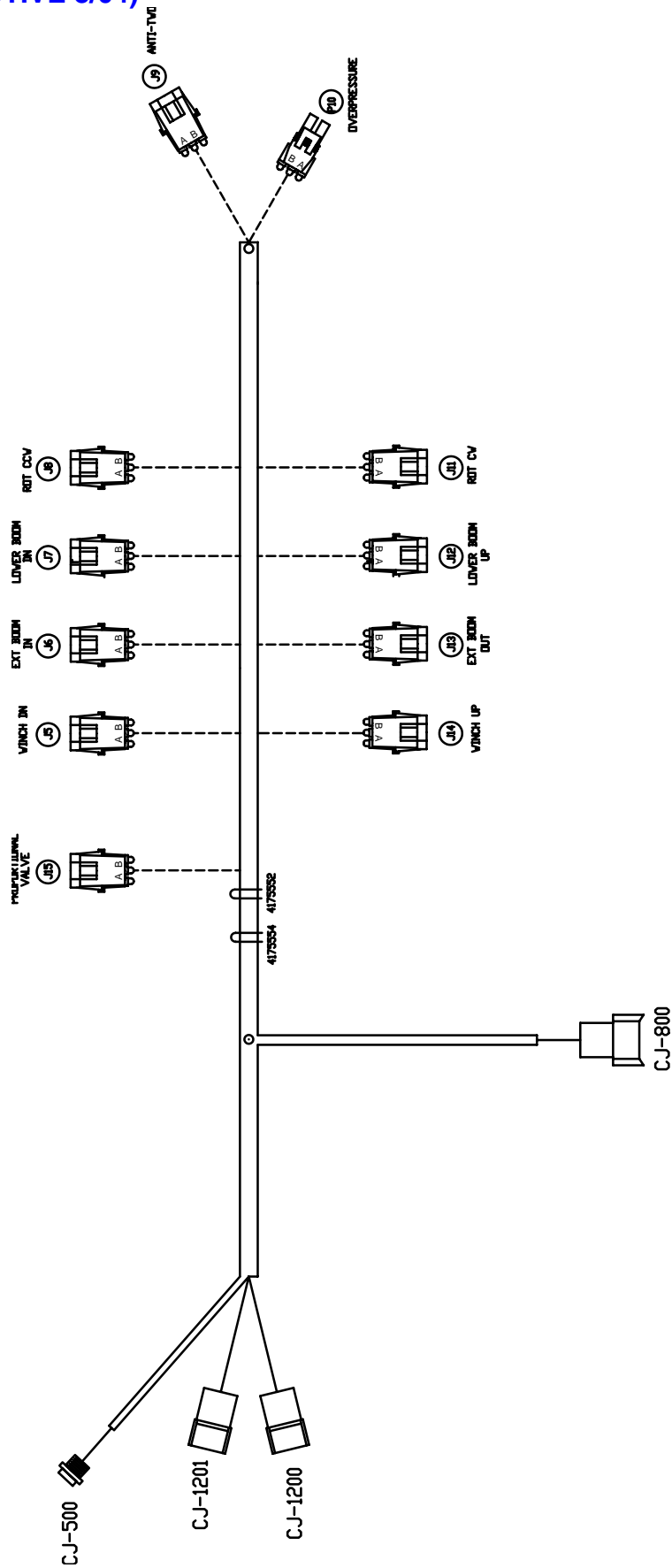

SCHEMATIC, RADIO REMOTE (77441101-2) (EFFECTIVE 8/04)

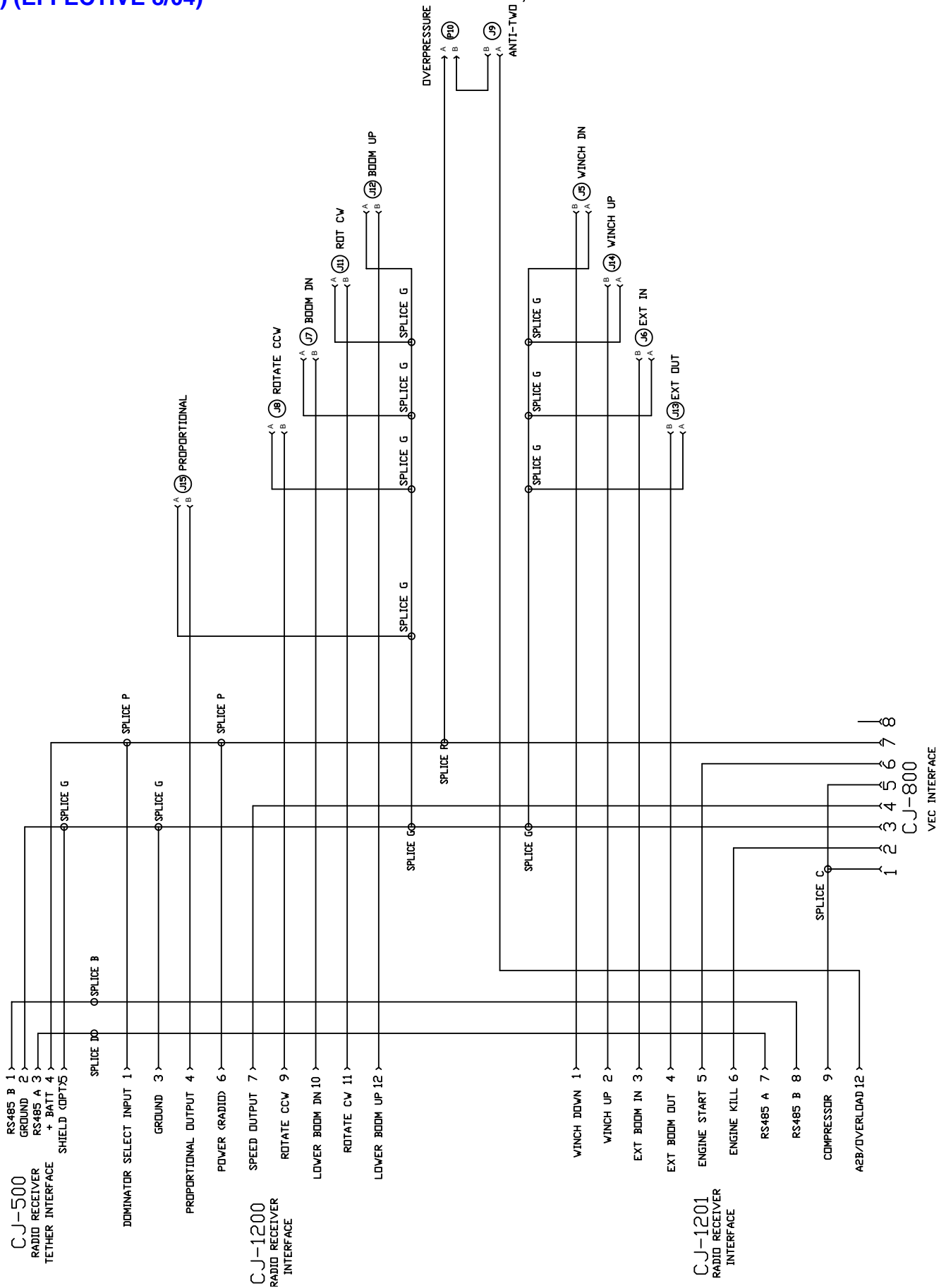

**CIRCUIT CHART, RADIO REMOTE
(77441101-3) (EFFECTIVE 8/04)**

LOCATOR CODE: CJ-500		BRAD/HARRIS: BR5A00A18A120				
TERM: 12124580		SEAL: 12015359				
CAVITY	COLOR	GA.	PRINT LABEL	TO	CON-SPLC	CAVITY
1	BRWN	22	RS485 B	TO	SPL B	-
2	BLK	22	GROUND	TO	SPL G	-
3	BLUE	22	RS485 A	TO	SPL D	-
4	WHT	22	+ BATT	TO	SPL P	-
5	GREY	22	SHIELD (OPTIONAL)	TO	SPL G	-

LOCATOR CODE: CJ-800		DUETSCH DT04-8PA				
TERM: 1060-16-0122		SEAL: 12015359				
CAVITY	COLOR	GA.	PRINT LABEL	TO	CON-SPLC	CAVITY
1	WHT	16	COMP PWR	TO	SPL C	-
2	WHT	16	ENG KILL	TO	CJ-1201	6
3	WHT	16	GROUND	TO	SPL G	-
4	WHT	16	SPEED OUTPUT	TO	CJ-1200	7
5	WHT	16	COMP PWR	TO	SPL C	-
6	WHT	16	ENGINE START	TO	CJ-1201	5
7	WHT	16	POWER	TO	SPL P	-
8	-	-	-	TO	-	-

LOCATOR CODE: CJ-1200		DEUTSCH: DTM06-12SA				
TERM: 1062-20-0122		SEAL: 12015359				
CAVITY	COLOR	GA.	PRINT LABEL	TO	CON-SPLC	CAVITY
1	WHT	16	DOM SEL INPUT	TO	SPL P	-
2	-	-	-	TO	-	-
3	WHT	16	GROUND	TO	SPL G	-
4	WHT	16	PROP VLV PWR	TO	J15	B
5	-	-	-	TO	-	-
6	WHT	16	POWER (RADIO)	TO	SPL P	-
7	WHT	16	SPEED OUTPUT	TO	CJ-800	4
8	-	-	-	TO	-	-
9	WHT	16	ROTATE CCW	TO	J8	B
10	WHT	16	BOOM DN	TO	J7	B
11	WHT	16	ROTATE CW	TO	J11	B
12	WHT	16	BOOM UP	TO	J12	B

LOCATOR CODE: CJ-1201		DEUTSCH: DTM06-12SB				
TERM: 1062-20-0122		SEAL: 12015359				
CAVITY	COLOR	GA.	PRINT LABEL	TO	CON-SPLC	CAVITY
1	WHT	16	WINCH DN	TO	J5	B
2	WHT	16	WINCH UP	TO	J14	B
3	WHT	16	EXTN	TO	J6	B
4	WHT	16	EXT OUT	TO	J13	B
5	WHT	16	ENGINE START	TO	CJ-800	6
6	WHT	16	ENGINE KILL	TO	CJ-800	2
7	WHT	16	RS485 A	TO	SPL D	-
8	WHT	16	RS485 B	TO	SPL B	-
9	WHT	16	COMP PWR	TO	SPL C	-
10	-	-	-	TO	-	-
11	-	-	-	TO	-	-
12	WHT	16	A2B/OVERLOAD	TO	J9	A

LOCATOR CODE: J5		PACKARD: 12010973				
TERM: 12124582		SEAL: 12015359				
CAVITY	COLOR	GA.	PRINT LABEL	TO	CON-SPLC	CAVITY
A	WHT	16	WINCH DN GRND	TO	SPL G	-
B	WHT	16	WINCH DN	TO	CJ-1201	1

LOCATOR CODE: J6		PACKARD: 12010973				
TERM: 12124582		SEAL: 12015359				
CAVITY	COLOR	GA.	PRINT LABEL	TO	CON-SPLC	CAVITY
A	WHT	16	EXT INGRND	TO	SPL G	-
B	WHT	16	EXTN	TO	CJ-1201	3

LOCATOR CODE: J7		PACKARD: 12010973				
TERM: 12124582		SEAL: 12015359				
CAVITY	COLOR	GA.	PRINT LABEL	TO	CON-SPLC	CAVITY
A	WHT	16	BOOM DN GRND	TO	SPL G	-
B	WHT	16	BOOM DN	TO	CJ-1200	10

LOCATOR CODE: J8		PACKARD: 12010973				
TERM: 12124582		SEAL: 12015359				
CAVITY	COLOR	GA.	PRINT LABEL	TO	CON-SPLC	CAVITY
A	WHT	16	ROT CCW GRND	TO	SPL G	-
B	WHT	16	ROTATE CCW	TO	CJ-1200	9

LOCATOR CODE: J9		PACKARD: 12010973				
TERM: 12124582		SEAL: 12015359				
CAVITY	COLOR	GA.	PRINT LABEL	TO	CON-SPLC	CAVITY
A	WHT	16	A2B/OVERLOAD	TO	CJ-1201	12
B	WHT	16	P10B TO J9B	TO	P10	B

LOCATOR CODE: P10		PACKARD: 12015792				
TERM: 12124580		SEAL: 12015359				
CAVITY	COLOR	GA.	PRINT LABEL	TO	CON-SPLC	CAVITY
A	WHT	16	OVR PRESS SW	TO	SPL P	-
B	WHT	16	P10B TO J9B	TO	J9	B

LOCATOR CODE: J11		PACKARD: 12010973				
TERM: 12124582		SEAL: 12015359				
CAVITY	COLOR	GA.	PRINT LABEL	TO	CON-SPLC	CAVITY
A	WHT	16	ROT CW GRND	TO	SPL G	-
B	WHT	16	ROTATE CW	TO	CJ-1200	11

LOCATOR CODE: J12		PACKARD: 12010973				
TERM: 12124582		SEAL: 12015359				
CAVITY	COLOR	GA.	PRINT LABEL	TO	CON-SPLC	CAVITY
A	WHT	16	BOOM UP GRND	TO	SPL G	-
B	WHT	16	BOOM UP	TO	CJ-1200	12

LOCATOR CODE: J13		PACKARD: 12010973				
TERM: 12124582		SEAL: 12015359				
CAVITY	COLOR	GA.	PRINT LABEL	TO	CON-SPLC	CAVITY
A	WHT	16	EX OUT GRND	TO	SPL G	-
B	WHT	16	EX OUT	TO	CJ-1201	4

LOCATOR CODE: J14		PACKARD: 12010973				
TERM: 12124582		SEAL: 12015359				
CAVITY	COLOR	GA.	PRINT LABEL	TO	CON-SPLC	CAVITY
A	WHT	16	WINCH UP GRND	TO	SPL G	-
B	WHT	16	WINCH UP	TO	CJ-1201	2

LOCATOR CODE: J15		PACKARD: 12010973				
TERM: 12124582		SEAL: 12015359				
CAVITY	COLOR	GA.	PRINT LABEL	TO	CON-SPLC	CAVITY
A	WHT	16	PROP VLV GRND	TO	SPL G	-
B	WHT	16	PROP VLV PWR	TO	CJ-1200	4

LOCATOR CODE: -		SPLICE B				
CAVITY	COLOR	GA.	PRINT LABEL	TO	CON-SPLC	CAVITY
-	BRN	22	RS485 B	TO	CJ-500	1
-	WHT	16	RS485 B	TO	CJ-1201	8

LOCATOR CODE: -		SPLICE C				
CAVITY	COLOR	GA.	PRINT LABEL	TO	CON-SPLC	CAVITY
-	WHT	16	COMP PWR	TO	CJ-1201	9
-	WHT	16	COMP PWR	TO	CJ-800	1
-	WHT	16	COMP PWR	TO	CJ-800	5

LOCATOR CODE: -		SPLICE D				
CAVITY	COLOR	GA.	PRINT LABEL	TO	CON-SPLC	CAVITY
-	BLUE	22	RS485 A	TO	CJ-500	3
-	WHT	16	RS485 A	TO	CJ-1201	7

LOCATOR CODE: -		SPLICE G				
CAVITY	COLOR	GA.	PRINT LABEL	TO	CON-SPLC	CAVITY
-	WHT	16	WINCH DN GRND	TO	J5	A
-	WHT	16	EX IN GRND	TO	J6	A
-	WHT	16	BOOM DN GRND	TO	J7	A
-	WHT	16	ROT CCW GRND	TO	J8	A
-	WHT	16	ROT CW GRND	TO	J11	A
-	WHT	16	BOOM UP GRND	TO	J12	A
-	WHT	16	EX OUT GRND	TO	J13	A
-	WHT	16	WINCH UP GRND	TO	J14	A
-	WHT	16	PROP VLV GRND	TO	J15	A
-	WHT	16	GROUND	TO	CJ-500	2
-	WHT	22	SHIELD (OPTIONAL)	TO	CJ-500	5
-	WHT	16	GROUND	TO	CJ-800	3
-	WHT	16	GROUND	TO	CJ-1200	3

LOCATOR CODE: -		SPLICE P				
CAVITY	COLOR	GA.	PRINT LABEL	TO	CON-SPLC	CAVITY
-	WHT	16	POWER	TO	CJ-800	7
-	WHT	16	POWER (RADIO)	TO	CJ-1200	6
-	WHT	16	DOM SEL INPUT	TO	CJ1200	1
-	WHT	22	+ BATT	TO	CJ-500	4
-	WHT	16	OVR PRESS SW	TO	P10	A

CABLE ASM, RADIO REMOTE (70733351-1) (THROUGH 7/04)

ALL QUANTITIES ARE REFERENCE.

1.	77044573	SHROUD CONN 2-CONT	10
2.	77044574	TOWER CONNECTION 2-CONT	2
3.	77045887	TERM-MALE 16GA	20
4.	77045888	TERM-FEM 16GA	4
5.	77044927	CABLE SEAL - GRY 16GA	25
6.	70145941	CONN HOLD - 2 AMP	1
7.	70145942	CONN - 2 AMP	1
8.		SOCKET, RELAY	1
9.		TERMINAL	4
10.		RELAY	1
11.		PLUG	2

CONTINUED ON FOLLOWING PAGE

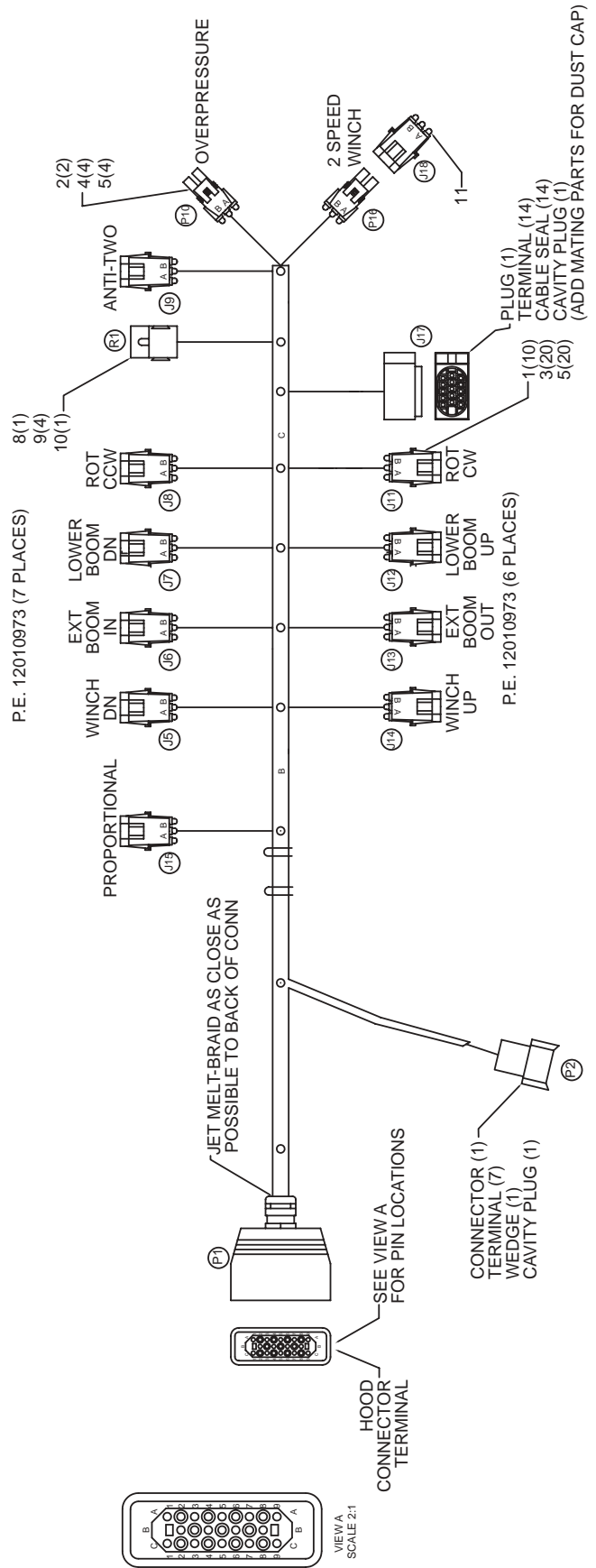

CABLE ASM (70733351-2) (THROUGH 7/04)

CONTINUED ON NEXT PAGE

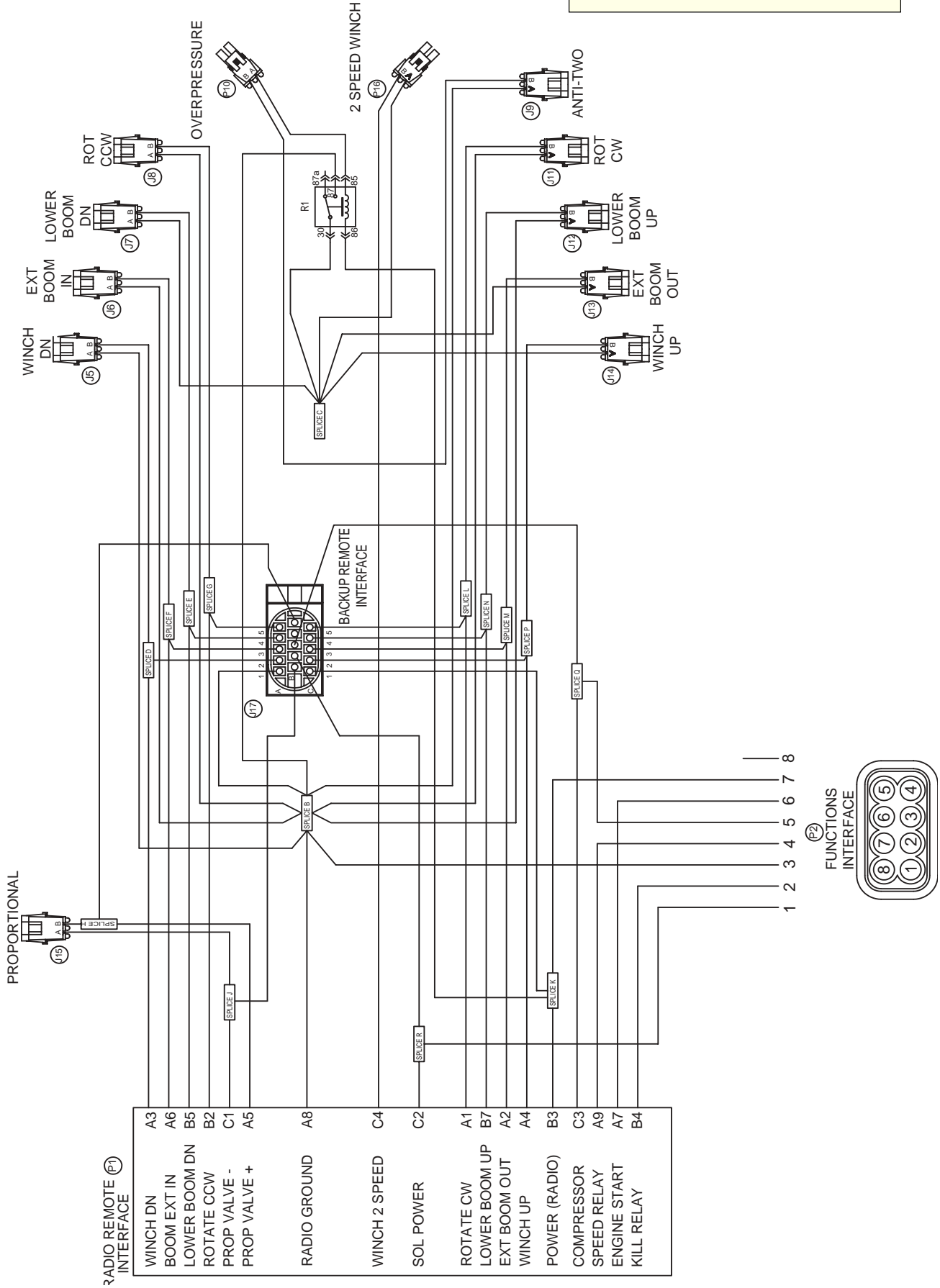

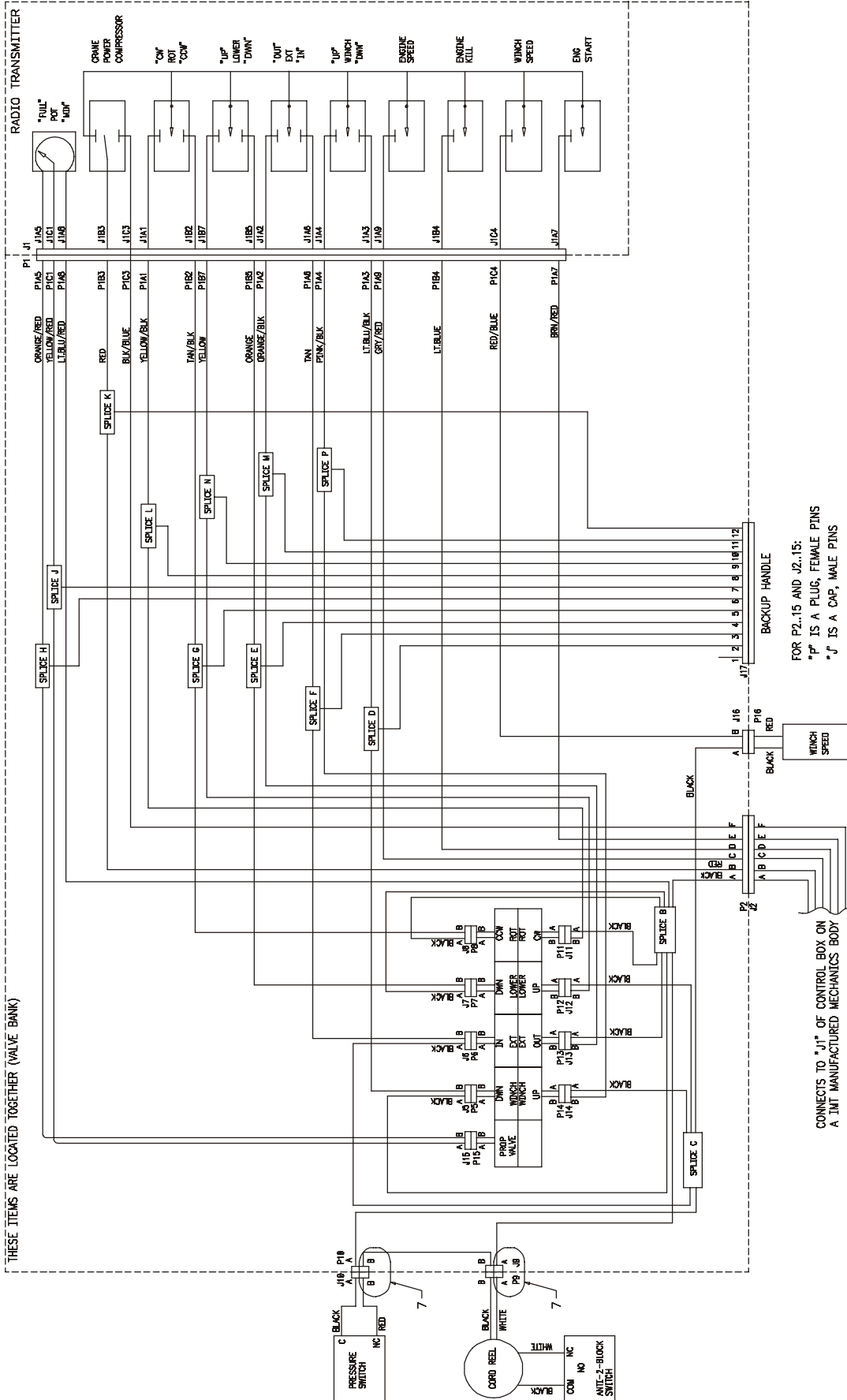

COUNTERBALANCE VALVE (73540035)

- | | | | |
|----|----------|---------------------|---|
| 1. | 73540051 | C'BAL VALVE BLOCK | 1 |
| 2. | 73540052 | C'BAL VALVE | 1 |
| 4. | 70145750 | ORIFICE | 1 |
| 6. | 77041561 | PRESSURE SWITCH | 1 |
| 7. | 72533477 | PLUG 7/16STR HOLHEX | 2 |

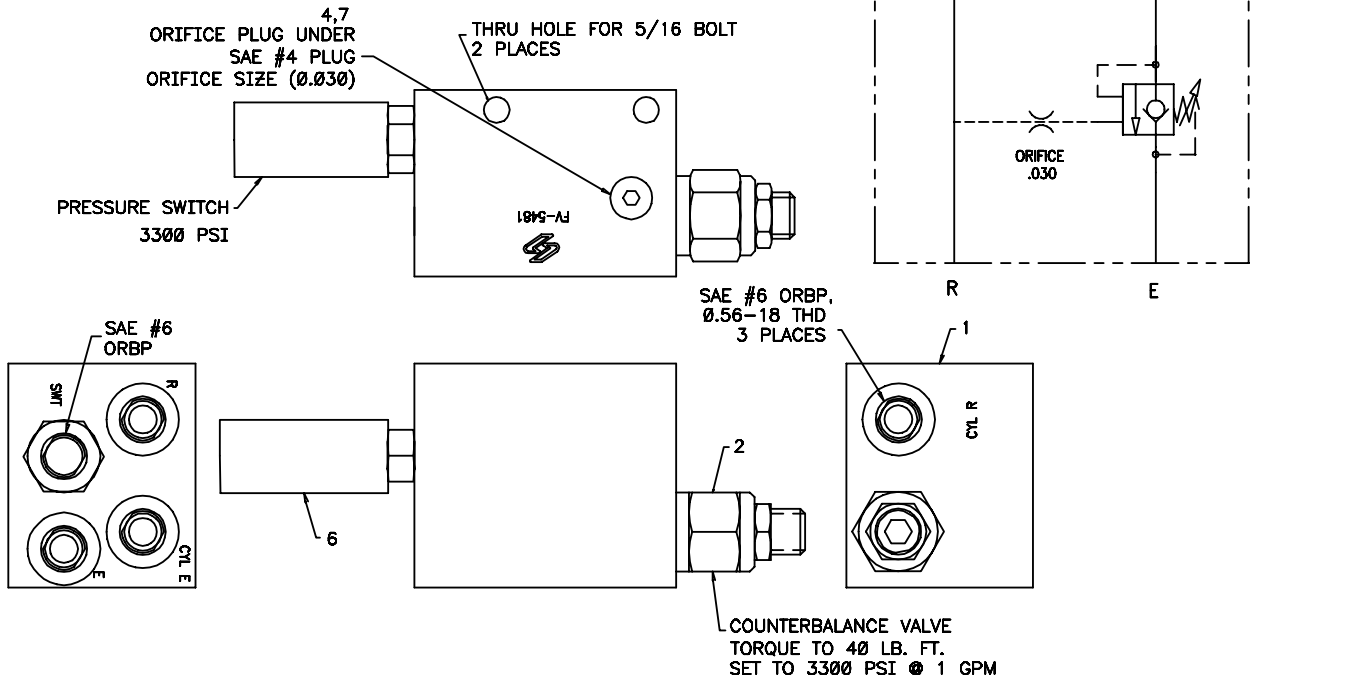

HYD KIT (91715652-1)

CONTINUED ON FOLLOWING PAGE

- | | | | |
|-----|----------|-----------------------------------|--------|
| 1. | 73733396 | VALVEBANK(INCL:10,11,15,16,20,21) | 1 |
| 2. | 72060005 | CAP SCR 1/4-20X1-1/4 HHGR5 | 4 |
| 3. | 72062104 | NUT 1/4-20 LOCK | 4 |
| 4. | 72063001 | WASHER 1/4 WRT | 4 |
| 5. | 51715639 | HOSE KIT (INCL:6-9,22) | 1 |
| 6. | 51395183 | HOSE ASM FF .50X35.5 #8#8 | 1REF |
| 7. | 51395309 | HOSE ASM FF .38X36 #8#8 | 2REF |
| 8. | 51395307 | HOSE ASM FF .38X23 #6#8 | 2REF |
| 9. | 51395306 | HOSE ASM FJ .25X48 #6#6 | 2REF |
| 10. | 72053763 | ELBOW #8MSTR #8MJIC 90° | 3REF |
| 11. | 72532666 | ELBOW #8MSTR #8MJIC 90° | 2REF |
| 12. | 72053764 | ELBOW #10MSTR #8MJIC 90° | 1 |
| 13. | 72532358 | ADAPTER #8MSTR #8MJIC | 2,1REF |
| 14. | 72533613 | ADAPTER #10MSTR #6MJIC | 2 |
| 15. | 72532700 | ELBOW #6MSTR #6MJIC XLG | 2REF |
| 16. | 72053761 | ELBOW #8MSTR #6MJIC 90° | 1REF |
| 17. | 72532670 | ELBOW #8MJIC #8FJIC 45° | 2 |
| 18. | 72532658 | ELBOW #8MJIC #8FJIC SWVL | 1 |
| 19. | 72532359 | ADAPTER #10MSTR #8MJIC | 1 |
| 20. | 72533052 | ADAPTER #8MSTR #6FSTR | 3REF |
| 21. | 72053760 | ELBOW #6MSTR #6MJIC 90° | 1REF |
| 22. | 51395556 | HOSE ASM FF .38X32 #8#8 | 1REF |
| 23. | 72532357 | ADAPTER #6MSTR #8MJIC | 2 |

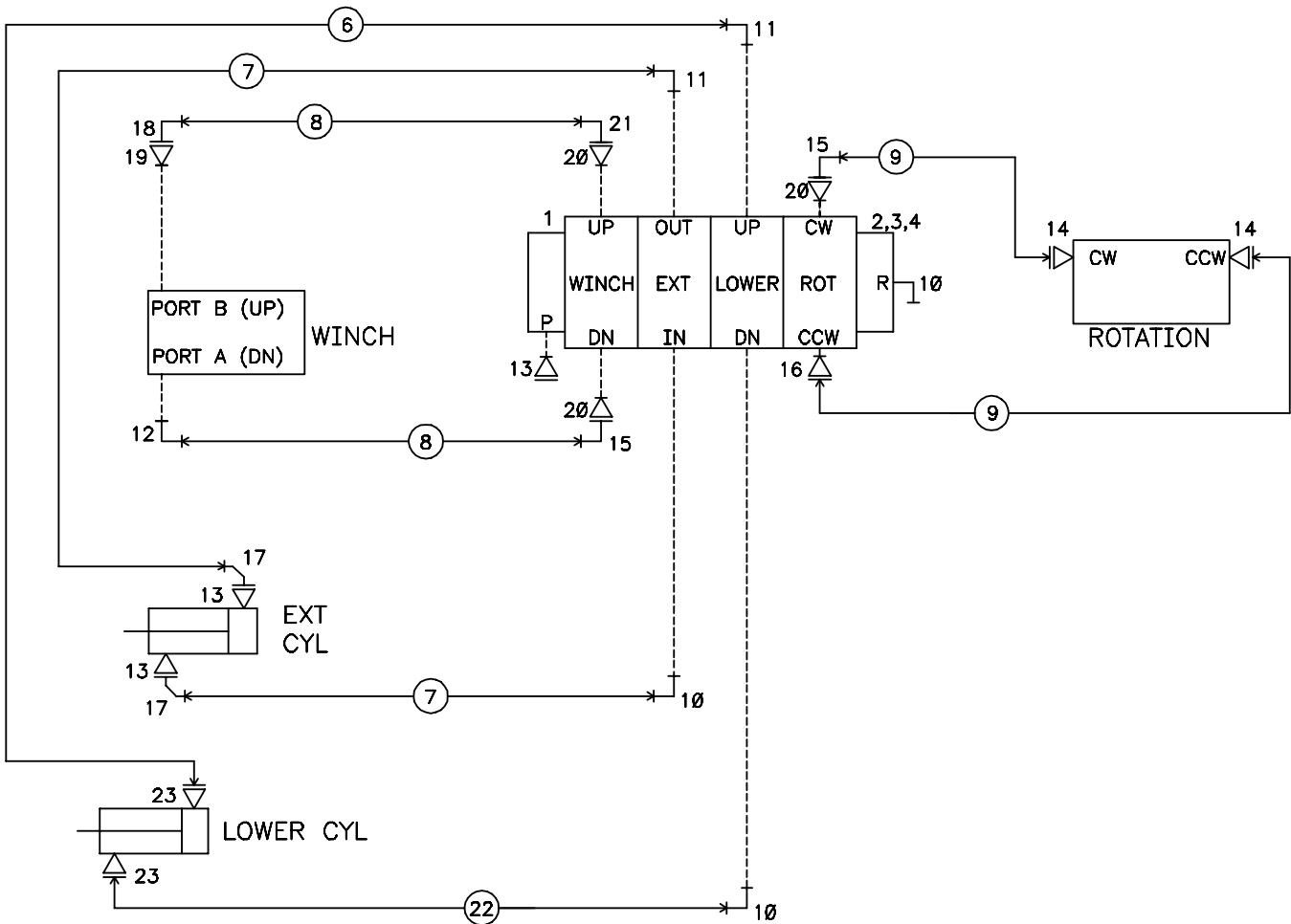

HYD KIT (91715652-2)

CONTINUED ON FOLLOWING PAGE

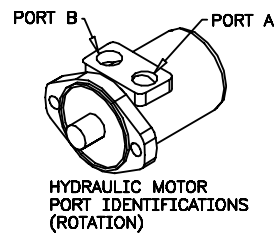
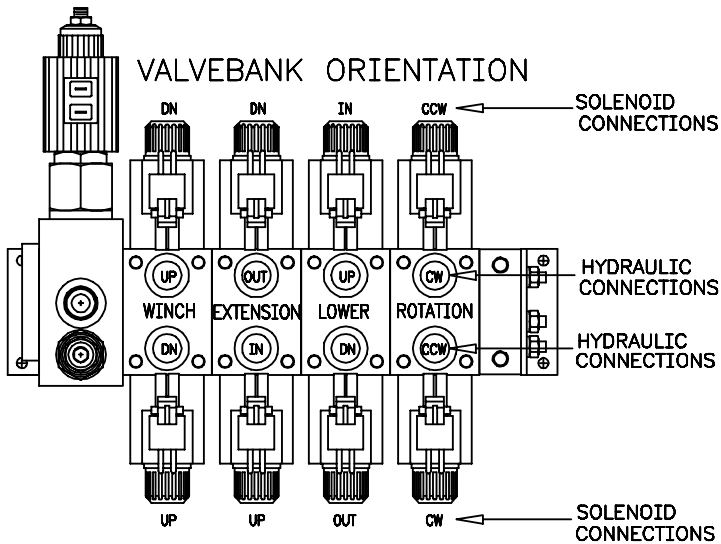
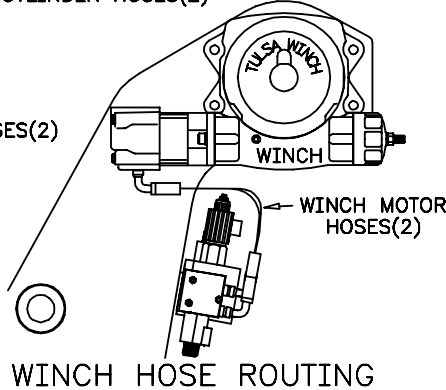
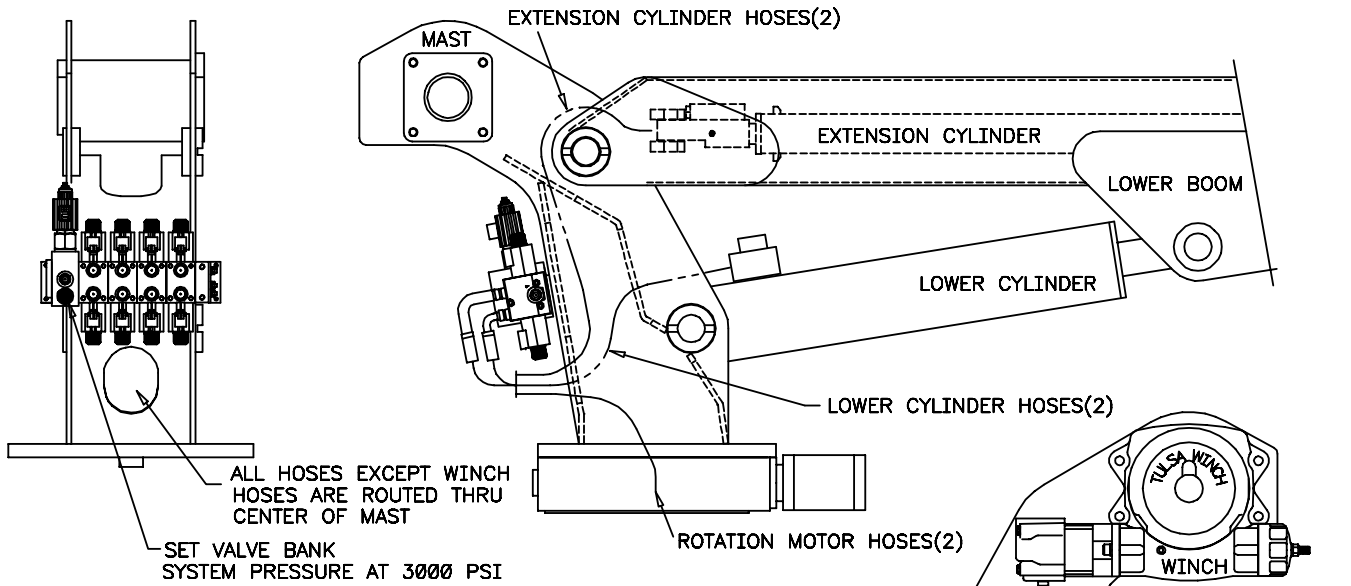

HYD KIT (91715652-3)

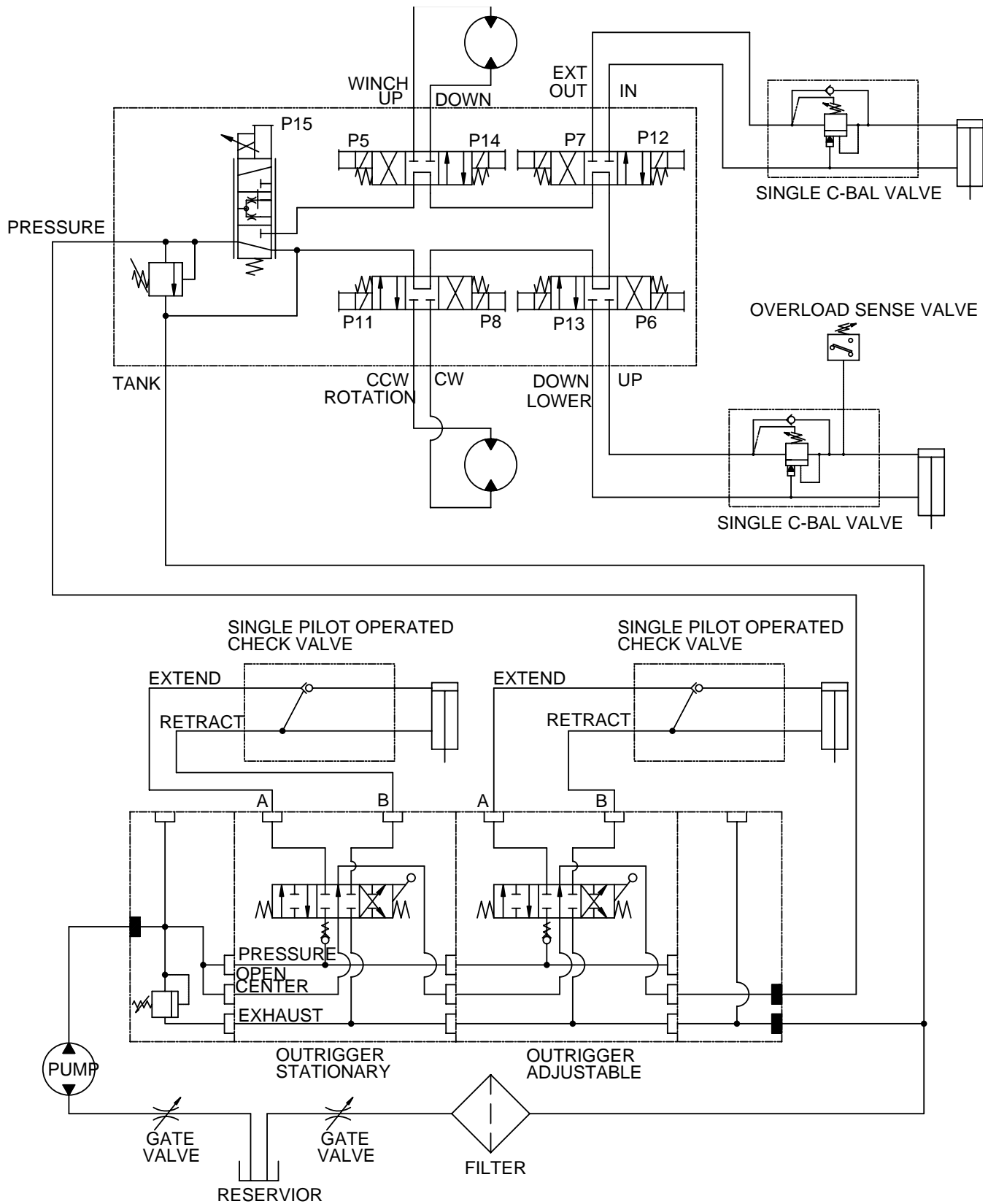

VALVEBANK (73733396)

1. 73540028	BLOCK-INLET	1	14. 77044574	CONNECTOR	9	15. 70394069	CABLE SEAL	2
2. 73540027	END CAP	1	15. 70394069	CABLE SEAL	2	16. 70145830	MTG BRACKET	2
3. 73054934	VALVE-PROPL FLOW CTRL	1	16. 70145830	MTG BRACKET	2	17. 77044595	VALVE DRIVER	1
77041556	PROPL VALVE-COIL ONLY	REF	17. 77044595	VALVE DRIVER	1	18. 72601704	MACH SCR #6-32X3/4 RDHD	3
4. 73054935	VALVE-RELIEF	1	18. 72601704	MACH SCR #6-32X3/4 RDHD	3	19. 72061705	WASHER #6 WRT	3
5. 73540044	VALVE SECTION	4	19. 72061705	WASHER #6 WRT	3	20. 77044594	CABLE SEAL	16
77041518	COIL-SOLENOID	REF	20. 77044594	CABLE SEAL	16	21. 70733394	CABLE ASM	1
6. 7Q072013	O-RING	10	21. 70733394	CABLE ASM	1	22. 72053763	ELBOW #8MSTR #8MJIC 90°	3
7. 72533477	PLUG 7/16STR HOLHEX	1	22. 72053763	ELBOW #8MSTR #8MJIC 90°	3	23. 72532666	ELBOW #8MSTR #8MJIC 90°	2
8. 70145829	EXPANDER PLUG	4	23. 72532666	ELBOW #8MSTR #8MJIC 90°	2	24. 72533603	PLUG 9/16STR HOLHEX	1
9. 60119363	ROD 1/4-20X12-1/2	2	24. 72533603	PLUG 9/16STR HOLHEX	1	25. 72533052	ADAPTER #8MSTR #6FSTR	3
10. 60119364	ROD 1/4-20X10-9/16	1	25. 72533052	ADAPTER #8MSTR #6FSTR	3	26. 72532700	ELBOW #6MSTR #6MJIC XLG	2
11. 72062000	NUT 1/4-20 HEX	5	26. 72532700	ELBOW #6MSTR #6MJIC XLG	2	27. 72053760	ELBOW #6MSTR #6MJIC 90°	1
12. 72063047	WASHER #10 LOCK	5	27. 72053760	ELBOW #6MSTR #6MJIC 90°	1	28. 72053761	ELBOW #8MSTR #6MJIC 90°	1
13. 77044574	CONNECTOR	9	28. 72053761	ELBOW #8MSTR #6MJIC 90°	1	29. 72532358	ADAPTER #8MSTR #8MJIC	1

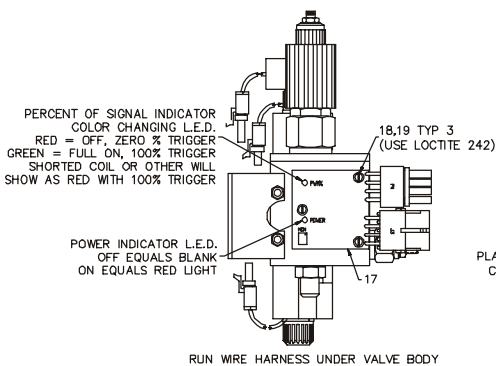
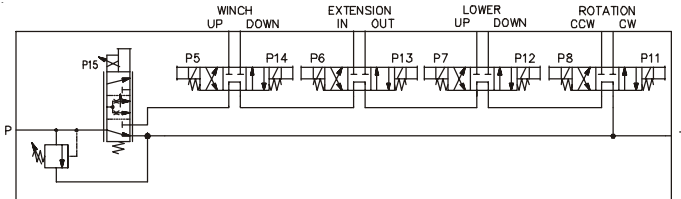

RUN WIRE HARNESS UNDER VALVE BODY

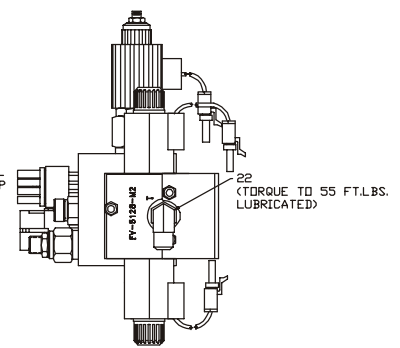
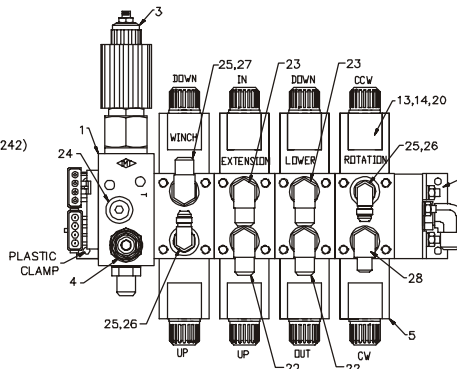

- NOTES:
 1. CONNECT J9 AND P10 TOGETHER
 2. ADD DUSK CAP TO J16

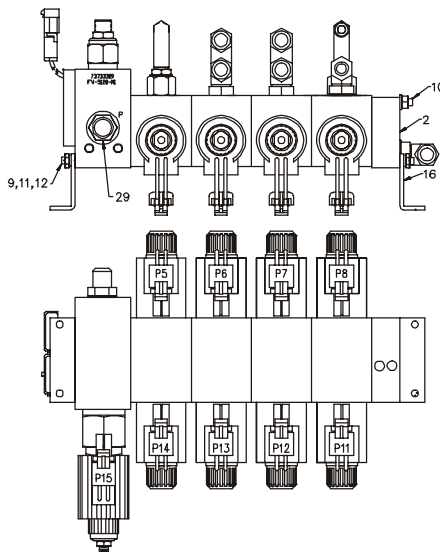

CABLE ASM (70733394-1)

- | | | | |
|-----|----------|-------------------------|-------|
| 1. | 77044573 | SHROUD CONN 2-CONT | 10REF |
| 2. | 77044574 | TOWER CONN 2-CONT | 2REF |
| 3. | 77044576 | TERMINAL-MALE 20-18GA | 24REF |
| 4. | 77044577 | TERMINAL-FEMALE 20-18GA | 8REF |
| 5. | 77044578 | CABLE SEAL GRN 20-18GA | 32REF |
| 6. | 77044620 | CONN RCPT | 1REF |
| 7. | 77044580 | SOCKETS | 23REF |
| 8. | | SOCKET, RELAY | 1REF |
| 9. | 77044623 | TOWER CONN | 1REF |
| 10. | 77044624 | SHROUD, CONN | 1REF |
| 11. | | TERMINAL | 4REF |

CONTINUED ON NEXT PAGE

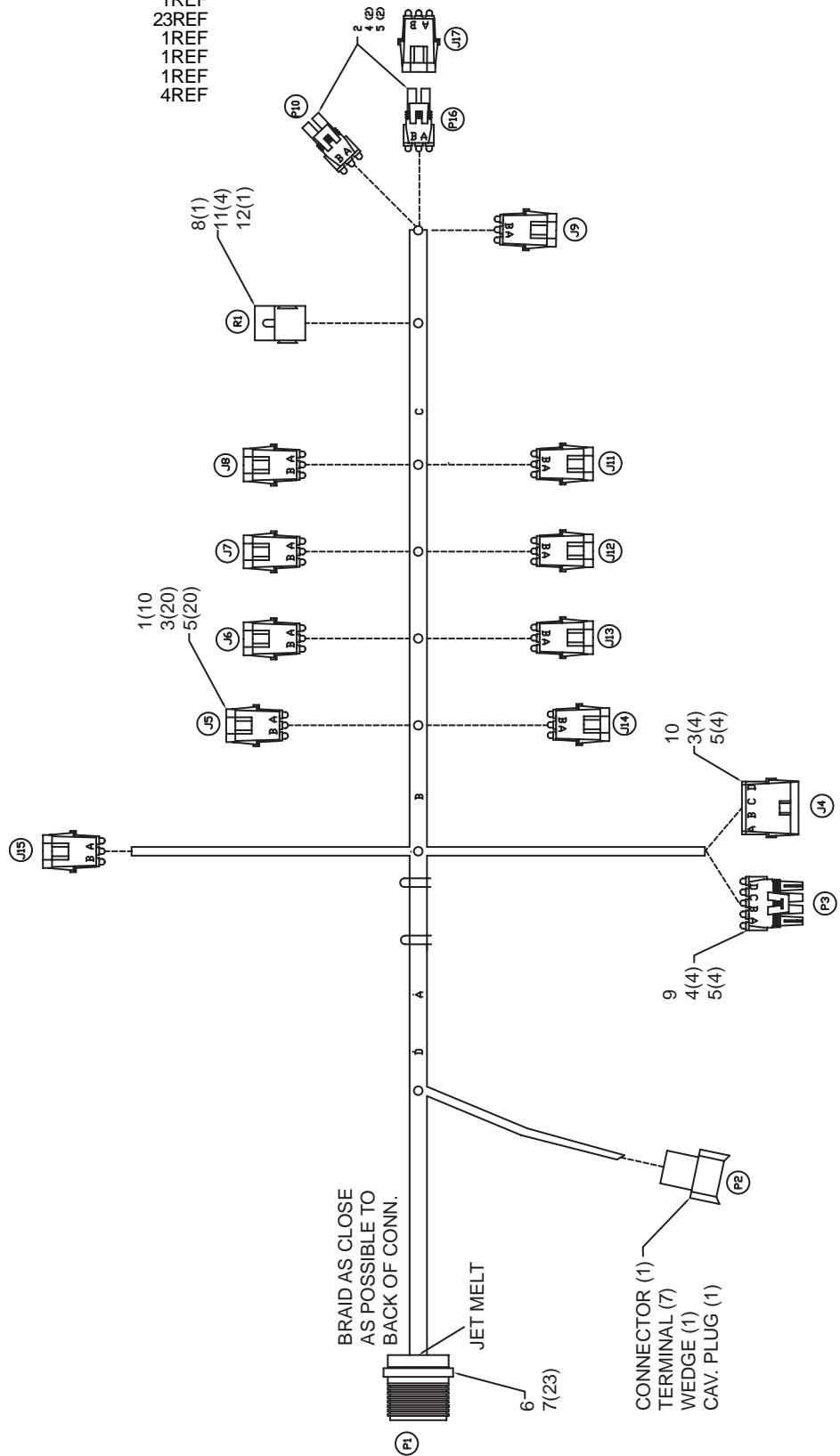

CABLE ASM (70733394-2)

LOCATOR CODE: P1		DEUTSCH: HD34-24-235059				
TERM	0462-201-16141	SEAL	CAVITY PLUG: 114017			
CAVITY	COLOR	GA.	PRINT LABEL	TO	CON-SPLC	CAVITY
A	WHT	18	ROD J11B	TO	J11	B
B	WHT	18	EXT J13B	TO	J13	B
C	WHT	18	WINCH J5B	TO	J5	B
D	WHT	18	WINCH J14B	TO	J14	B
E	WHT	18	J4A REF	TO	J4	A
F	WHT	18	EXT J6B	TO	J6	B
G	WHT	16	P2 6 ENG STRT	TO	P2	6
H	WHT	18	P3B SIG COMM	TO	P3	B
I	-	-	-	TO	-	-
J	WHT	18	P2 4 SPD RLA	TO	P2	4
K	WHT	18	ROD J8B	TO	J8	B
L	WHT	16	PENDANT PWR (+)	TO	SPL A	-
M	WHT	18	P2 2 KILL RLA	TO	P2	2
N	WHT	18	LOWER J7B	TO	J7	B
O	WHT	16	P1 0 SOL PWR	TO	P2	1
P	WHT	18	LOWER J12B	TO	J12	B
Q	-	-	-	TO	-	-
R	WHT	18	J4B VOLTAGE	TO	J4	B
S	WHT	18	P1S DN H	TO	SPL D	-
T	WHT	16	P2 5 COMPR	TO	P2	5
U	WHT	16	WNSPD P16B	TO	P16	B
V	-	-	-	TO	-	-
W	-	-	-	TO	-	-

LOCATOR CODE: P2		DEUTSCH: DT04-8PA				
TERM	1062-16-0122	SEAL	CAVITY PLUG: 114017			
CAVITY	COLOR	GA.	PRINT LABEL	TO	CON-SPLC	CAVITY
1	WHT	16	P1 0 SOL PWR	TO	P1	D
2	WHT	18	P2 2 KILL RLA	TO	P1	M
3	WHT	16	P2 3 BAT (-)	TO	SPL B	-
4	WHT	18	P2 4 SPD RLA	TO	P1	J
5	WHT	16	P2 5 COMPR	TO	P1	T
6	WHT	16	P2 6 ENG STRT	TO	P1	G
7	WHT	16	P2 7 IGN SOL	TO	SPL A	-
8	-	-	-	TO	-	-

LOCATOR CODE: P3		PACKARD: 12015797				
TERM	12089188	SEAL	CAVITY PLUG: 12015323			
CAVITY	COLOR	GA.	PRINT LABEL	TO	CON-SPLC	CAVITY
A	WHT	16	P3A POWER (+)	TO	SPL A	-
B	WHT	18	P3B SIG COMM	TO	P1	H
C	WHT	16	PRPVLV (-)	TO	J15	A
D	WHT	16	PRPVLV (+)	TO	J15	B

LOCATOR CODE: J4		PACKARD: 12010974				
TERM	12089040	SEAL	CAVITY PLUG: 12015323			
CAVITY	COLOR	GA.	PRINT LABEL	TO	CON-SPLC	CAVITY
A	WHT	18	J4A REF	TO	J1	E
B	WHT	18	J4B VOLTAGE	TO	J1	R
C	WHT	18	J4C DN H	TO	SPL D	-
D	WHT	16	J4D PWR COM	TO	SPL B	-

LOCATOR CODE: J5		PACKARD: 12010973				
TERM	12089040	SEAL	CAVITY PLUG: 12015323			
CAVITY	COLOR	GA.	PRINT LABEL	TO	CON-SPLC	CAVITY
A	WHT	16	WINCH J5A	TO	SPL B	-
B	WHT	18	WINCH J5B	TO	P1	C

LOCATOR CODE: J6		PACKARD: 12010973				
TERM	12089040	SEAL	CAVITY PLUG: 12015323			
CAVITY	COLOR	GA.	PRINT LABEL	TO	CON-SPLC	CAVITY
A	WHT	16	EXT J6A	TO	SPL B	-
B	WHT	18	EXT J6B	TO	P1	F

LOCATOR CODE: J7		PACKARD: 12010973				
TERM	12089040	SEAL	CAVITY PLUG: 12015323			
CAVITY	COLOR	GA.	PRINT LABEL	TO	CON-SPLC	CAVITY
A	WHT	16	LOWER J7A	TO	SPL C	-
B	WHT	18	LOWER J7B	TO	P1	N

LOCATOR CODE: J8		PACKARD: 12010973				
TERM	12089040	SEAL	CAVITY PLUG: 12015323			
CAVITY	COLOR	GA.	PRINT LABEL	TO	CON-SPLC	CAVITY
A	WHT	16	ROD J8A	TO	SPL B	-
B	WHT	18	ROD J8B	TO	P1	K

LOCATOR CODE: J9		PACKARD: 12010973				
TERM	12089040	SEAL	CAVITY PLUG: 12015323			
CAVITY	COLOR	GA.	PRINT LABEL	TO	CON-SPLC	CAVITY
A	WHT	16	ATB J9A	TO	SPL B	-
B	WHT	16	P10B & P9B	TO	P10	B

LOCATOR CODE: P10		PACKARD: 12015792				
TERM	12089188	SEAL	CAVITY PLUG: 12015323			
CAVITY	COLOR	GA.	PRINT LABEL	TO	CON-SPLC	CAVITY
A	WHT	16	OPSI P10A	TO	R1	85
B	WHT	16	P10B & J9B	TO	J9	B

LOCATOR CODE: J11		PACKARD: 12010973				
TERM	12089040	SEAL	CAVITY PLUG: 12015323			
CAVITY	COLOR	GA.	PRINT LABEL	TO	CON-SPLC	CAVITY
A	WHT	16	ROD J11A	TO	SPL B	-
B	WHT	18	ROD J11B	TO	P1	A

LOCATOR CODE: J12		PACKARD: 12010973				
TERM	12089040	SEAL	CAVITY PLUG: 12015323			
CAVITY	COLOR	GA.	PRINT LABEL	TO	CON-SPLC	CAVITY
A	WHT	16	LOWER J12A	TO	SPL B	-
B	WHT	18	LOWER J12B	TO	P1	P

LOCATOR CODE: J13		PACKARD: 12010973				
TERM	12089040	SEAL	CAVITY PLUG: 12015323			
CAVITY	COLOR	GA.	PRINT LABEL	TO	CON-SPLC	CAVITY
A	WHT	16	EXT J13A	TO	SPL C	-
B	WHT	18	EXT J13B	TO	P1	B

LOCATOR CODE: J14		PACKARD: 12010973				
TERM	12089040	SEAL	CAVITY PLUG: 12015323			
CAVITY	COLOR	GA.	PRINT LABEL	TO	CON-SPLC	CAVITY
A	WHT	16	WINCH J14A	TO	SPL C	-
B	WHT	18	WINCH J14B	TO	P1	D

LOCATOR CODE: J15		PACKARD: 12010973				
TERM	12089040	SEAL	CAVITY PLUG: 12015323			
CAVITY	COLOR	GA.	PRINT LABEL	TO	CON-SPLC	CAVITY
A	WHT	16	PRPVLV (-)	TO	P3	C
B	WHT	16	PRPVLV (+)	TO	P3	D

LOCATOR CODE: P16		PACKARD: 12015792				
TERM	12089188	SEAL	CAVITY PLUG: 12015323			
CAVITY	COLOR	GA.	PRINT LABEL	TO	CON-SPLC	CAVITY
A	WHT	16	WNSPD P16A	TO	SPL C	-
B	WHT	16	WNSPD P16B	TO	P1	U

LOCATOR CODE: J5		PACKARD: 12010973				
TERM	-	PLUG	12010300			
CAVITY	COLOR	GA.	PRINT LABEL	TO	CON-SPLC	CAVITY
A	-	-	-	TO	P16	-
B	-	-	-	TO	P16	-

LOCATOR CODE: -		SPLICE A				
CAVITY	COLOR	GA.	PRINT LABEL	TO	CON-SPLC	CAVITY
-	WHT	16	PENDANT PWR (+)	TO	P1	L
-	WHT	16	P2 7 IGN SOL	TO	P2	7
-	WHT	16	P3A POWER (+)	TO	P3	A

LOCATOR CODE: -		SPLICE B				
CAVITY	COLOR	GA.	PRINT LABEL	TO	CON-SPLC	CAVITY
-	WHT	16	WINCH J5A	TO	J5	A
-	WHT	16	RELAY GND	TO	R1	87
-	WHT	16	P2 3 BAT (-)	TO	P2	3
-	WHT	16	J4D PWR COM	TO	J4	D
-	WHT	16	ROD J11A	TO	J11	A
-	WHT	16	LOWER J12A	TO	J12	A
-	WHT	16	EXT J6A	TO	J6	A
-	WHT	16	ROD J8A	TO	J8	A
-	WHT	16	ATB J9A	TO	J9	A

LOCATOR CODE: -		SPLICE C				
CAVITY	COLOR	GA.	PRINT LABEL	TO	CON-SPLC	CAVITY
-	WHT	16	LOWER J7A	TO	J7	A
-	WHT	16	ATB & OPRES GRD	TO	R1	30
-	WHT	16	EXT J13A	TO	J13	A
-	WHT	16	WINCH J14A	TO	J14	A
-	WHT	16	WNSPD P16A	TO	P16	A

LOCATOR CODE: -		SPLICE D				
CAVITY	COLOR	GA.	PRINT LABEL	TO	CON-SPLC	CAVITY
-	WHT	18	P1S DN H	TO	P1	S
-	WHT	16	RELAY PWR (+)	TO	R1	86
-	WHT	18	J4C DN H	TO	J4	C

LOCATOR CODE: R1		RELAY SOCKET: PACKARD 12065685, 12052834				
TERM	12066614	RELAY	HELLA 87411 (SEALED)			
CAVITY	COLOR	GA.	PRINT LABEL	TO	CON-SPLC	CAVITY
30	WHT	16	ATB & OPRES GRD	TO	SPL C	-
87	WHT	16	RELAY GRD	TO	SPL B	-
87A	-	-	-	TO	-	-
86	WHT	16	RELAY PWR (+)	TO	SPL D	-
85	WHT	16	OPSI P10A	TO	P10	A

LOCATOR CODE	CAVITY	PRINT LABEL	3000 FUNCTION
P1	B	EXT J13B	INNER BOOM DOWN
P1	C	WINCH J5A	EXTENSION BOOM IN
P1	D	WINCH J14B	EXTENSION BOOM OUT
P1	F	EXT J6B	INNER BOOM UP
P1	N	LOWER J7B	OUTER BOOM UP
P1	P	LOWER J12B	OUTER BOOM DOWN
J5	A	WINCH J5B	EXTENSION BOOM IN
J5	B	WINCH J5B	EXTENSION BOOM IN
J6	A	EXT J6A	INNER BOOM UP
J6	B	EXT J6B	INNER BOOM UP
J7	A	LOWER J7A	OUTER BOOM UP
J7	B	LOWER J7B	OUTER BOOM UP
J12	A	LOWER J12A	OUTER BOOM DOWN
J12	B	LOWER J12B	OUTER BOOM DOWN
J13	A	EXT J13A	INNER BOOM DOWN
J13	B	EXT J13B	INNER BOOM DOWN
J14	A	WINCH J14A	EXTENSION BOOM OUT
J14	B	WINCH J14B	EXTENSION BOOM OUT

RADIO RMT KIT (70733354-1)

- | | | | |
|----|----------|-------------------------------|---|
| 1. | 73733392 | RADIO REMOTE RECEIVER | 1 |
| 2. | 73733393 | TRANSMITTER | 1 |
| 3. | 70146100 | BATTERY-VERSAPACK | 2 |
| 5. | 70146279 | BATTERY CHARGER (EFF 10/02) | 1 |
| | 70146102 | BATTER CHARGER (THRU 9/30/02) | 1 |
| 6. | 70146103 | MAGNET | 1 |

(NOTE: ITEM #5, 70146279, CAN BE PURCHASED AS PART OF KIT 90042094.)

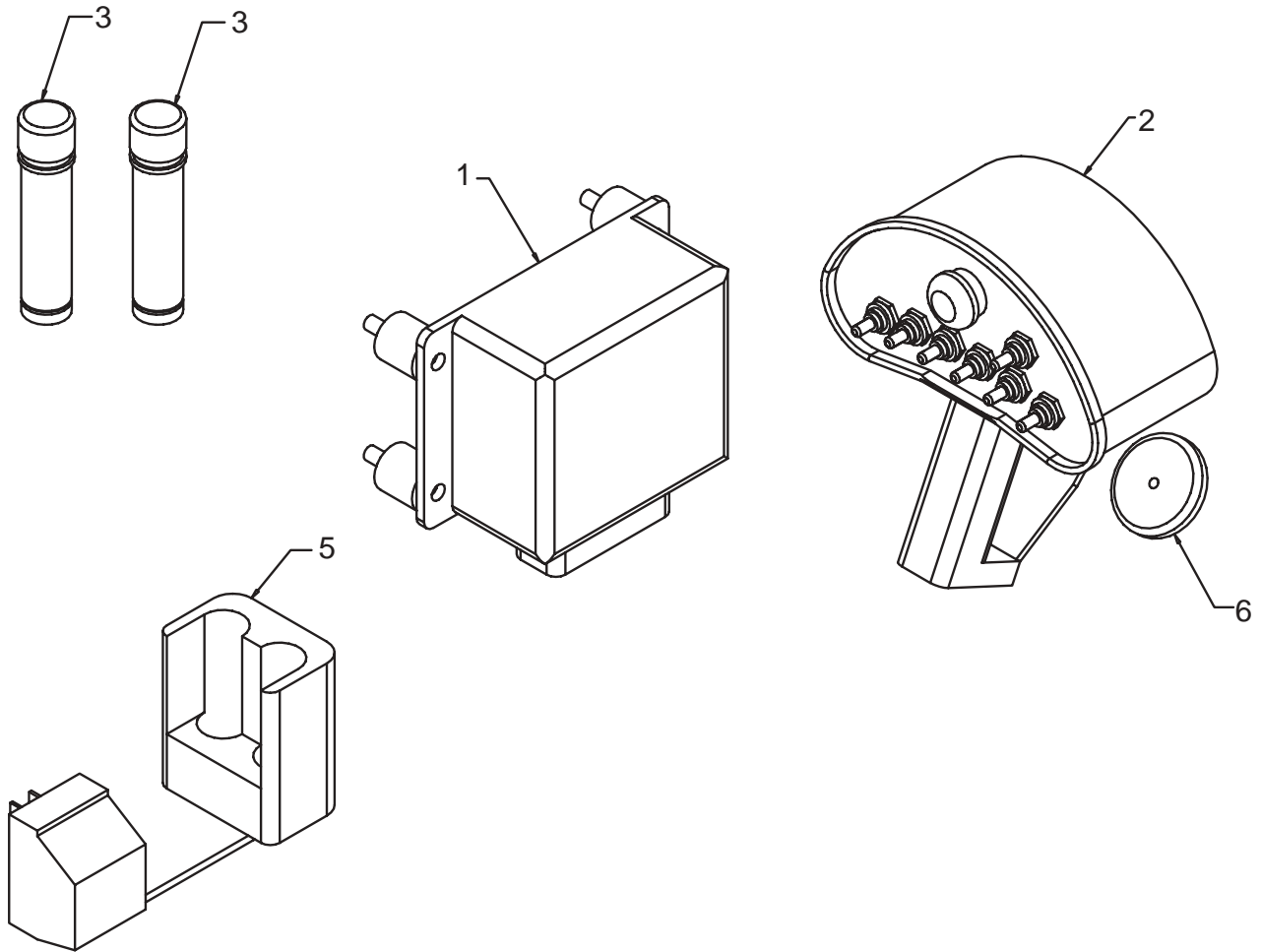

RADIO RMT KIT (70733354-2)

- ALL SWITCHES ARE MOMENTARY UNLATCHED TYPE

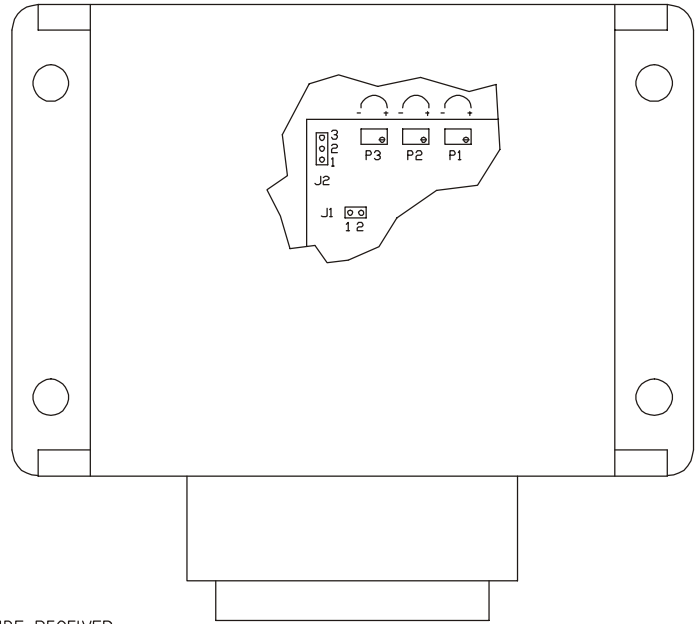
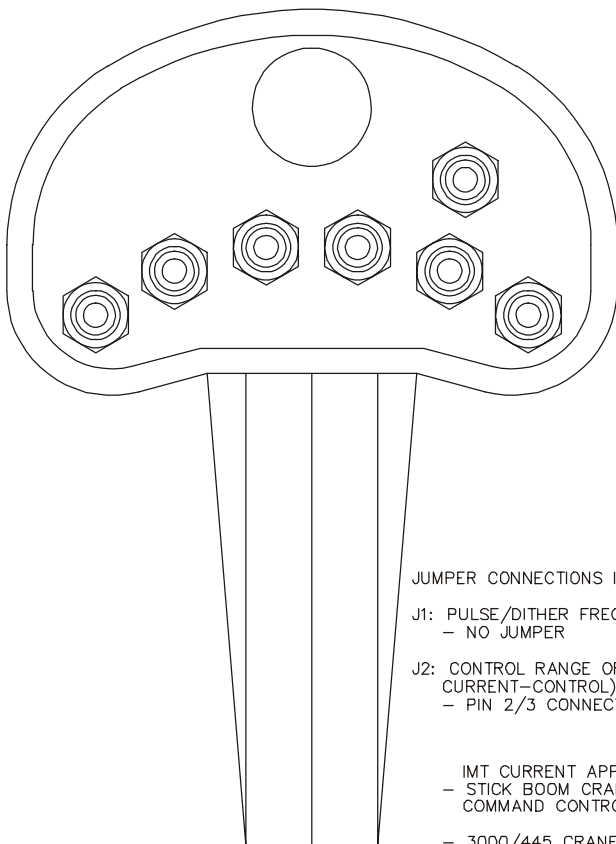

JUMPER CONNECTIONS INSIDE RECEIVER

- J1: PULSE/DITHER FREQUENCY
- NO JUMPER
- J2: CONTROL RANGE OF OUTPUT CURRENT (ONLY CURRENT-CONTROL)
- PIN 2/3 CONNECTED: 0-2A

- IMT CURRENT APPLICATIONS:
- STICK BOOM CRANES (PIN 2/3 CONNECTED: 0-2A)
COMMAND CONTROL PROP VALVE (EHPFD-16-N-0-10-12DL)
 - 3000/445 CRANES (PIN 2/3 CONNECTED: 0-2A)
 - STERLING PROP VALVE (JP04C-31-50-N-IMT)

CONNECTOR PIN LETTER	IMT ASSIGNED FUNCTION
A1	ROT CW
A2	EXT OUT
A3	WINCH DN
A4	WINCH UP
A5	PROP VALVE +
A6	EXT IN
A7	ENGINE START
A8	RADIO GND
A9	SPEED RELAY
B1	NOT USED
B2	ROT CCW
B3	RADIO POWER
B4	KILL RELAY
B5	LOW DN
B6	NOT USED
B7	LOWER UP
B8	NOT USED
B9	NOT USED
C1	PROP VALVE -
C2	NOT USED
C3	COMPRESSOR
C4	WINCH 2 SPD
C5	NOT USED
C6	NOT USED
C7	NOT USED
C8	NOT USED
C9	NOT USED

- P1: TRIMMING POTENTIOMETER FOR MAXIMUM VALUES. ON TRANSMITTER HANDLE, ENGAGE ROTATION CW OR CCW FUNCTION SWITCH AND PULL TRIGGER FULLY ON. CRANE MAY OR MAY NOT BEGIN TO MOVE AT THIS TIME DUE TO P1 INITIAL SETTING. TURN P1 POTENTIOMETER COUNTERCLOCKWISE UNTIL DESIRED MAXIMUM SPEED IS OBTAINED OR UNTIL SPEED NO LONGER CONTINUES TO INCREASE.
- P2: TRIMMING POTENTIOMETER FOR INITIAL VALUE ADJUSTMENT. ON TRANSMITTER, ENGAGE ROTATION CW OR CCW FUNCTION SWITCH. WITHOUT PULLING TRIGGER, ADJUST P2 COUNTERCLOCKWISE UNTIL CRANE BEGINS TO MOVE. AT THIS TIME, ADJUST P2 CLOCKWISE UNTIL NO MOVEMENT IS DETECTED. SLIGHTLY ENGAGE TRIGGER AND ADJUST P2 TO FINE TUNE.
- P3: TRIMMING POTENTIOMETER TO ADJUST DITHERAMPLITUDE: ADJUST CLOCKWISE OR COUNTERCLOCKWISE FOR SMOOTHNESS OF OPERATION.

CHASSIS WIRING HARNESS (99903340)

NOTE:

TO BE USED ONLY ON SHIP-OUT TELESCOPIC CRANES W/O IMT-INSTALLED BODIES.

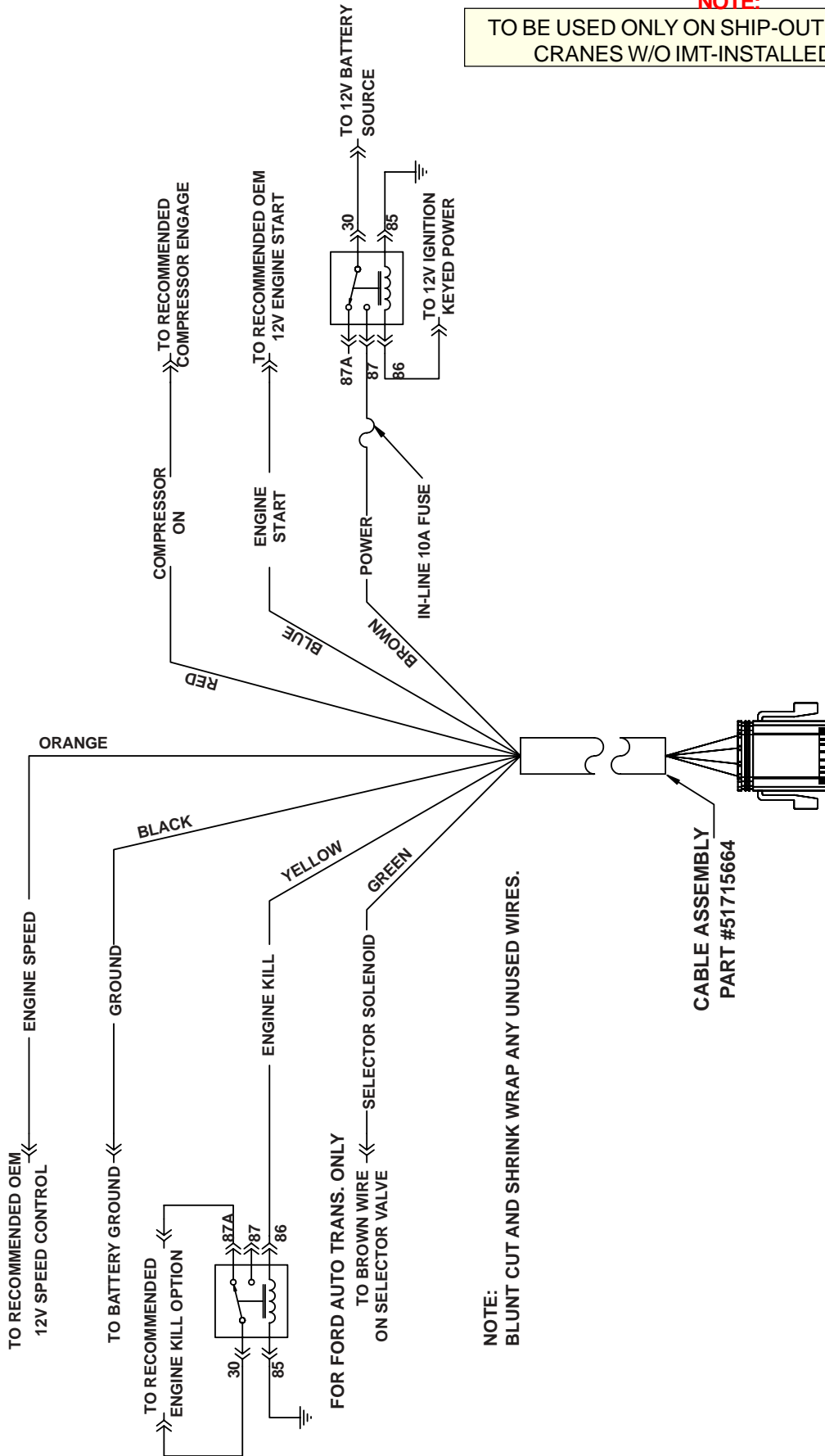

NOTE:
BLUNT CUT AND SHRINK WRAP ANY UNUSED WIRES.

CABLE ASSEMBLY
PART #51715664

WIRE ROUTING, PROP REMOTE CONTROL (90713879)

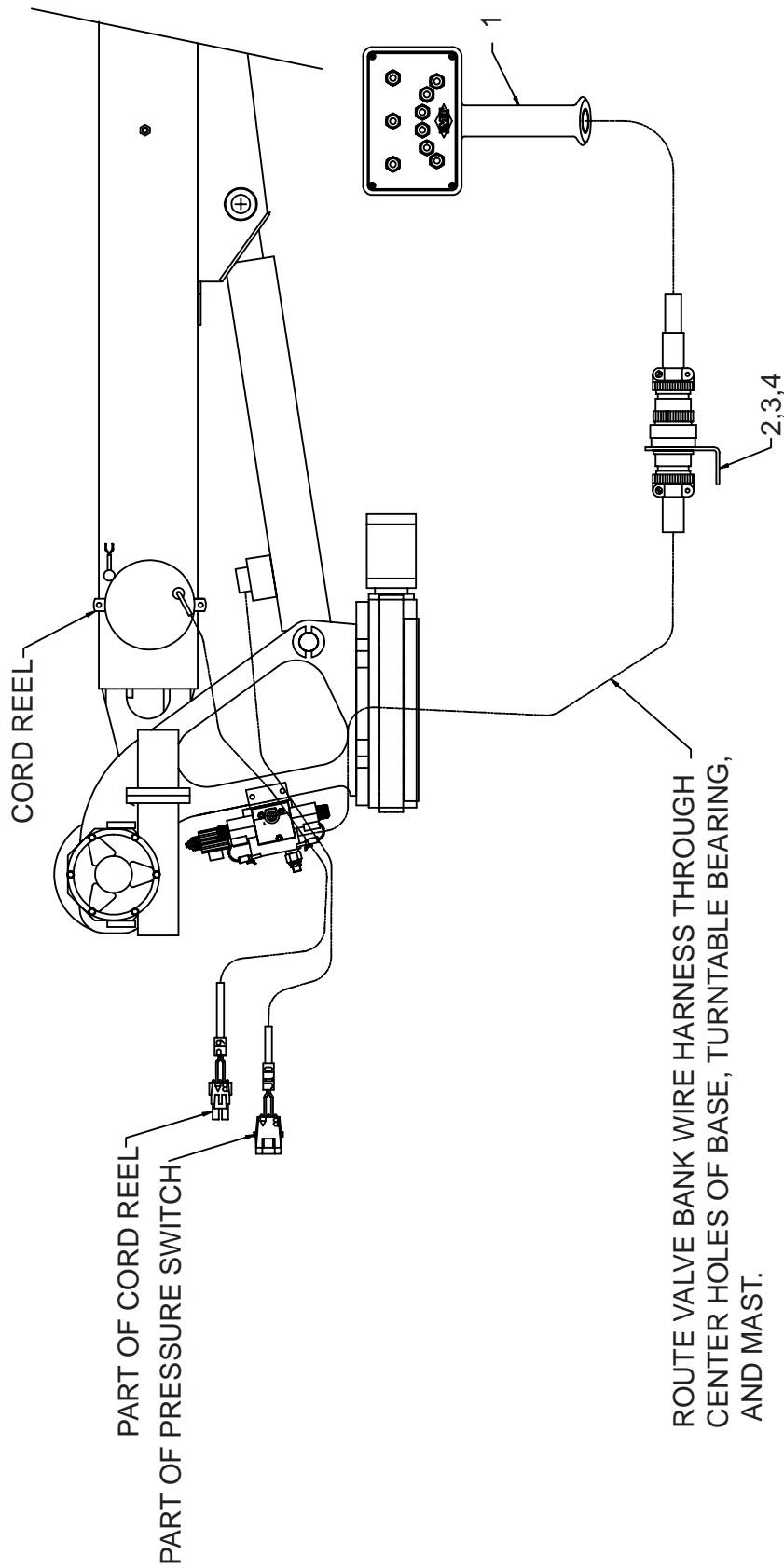

SEE 99900855 FOR WIRE CONNECTIONS, ELECTRICAL SCHEMATIC AND PARTS LIST.

ELECTRICAL SCHEMATIC, PROP RE-MOTE CONTROL (99900855)

- | | | | |
|----|----------|-------------------------|---|
| 1. | 51713182 | HANDLE ASM | 1 |
| 2. | 60119299 | BRACKET | 1 |
| 3. | 77044645 | NUT-DEUTSCH CONNECTOR | 1 |
| 4. | 77044646 | LOCK WASHER -DTSCH CONN | 1 |
| 5. | 51713343 | CABLE ASM 14GA/2 WIRE | 1 |
| 6. | 70034439 | LOCK WIRE LEAD SEAL 8" | 2 |
| 7. | 77041597 | RELAY | 1 |

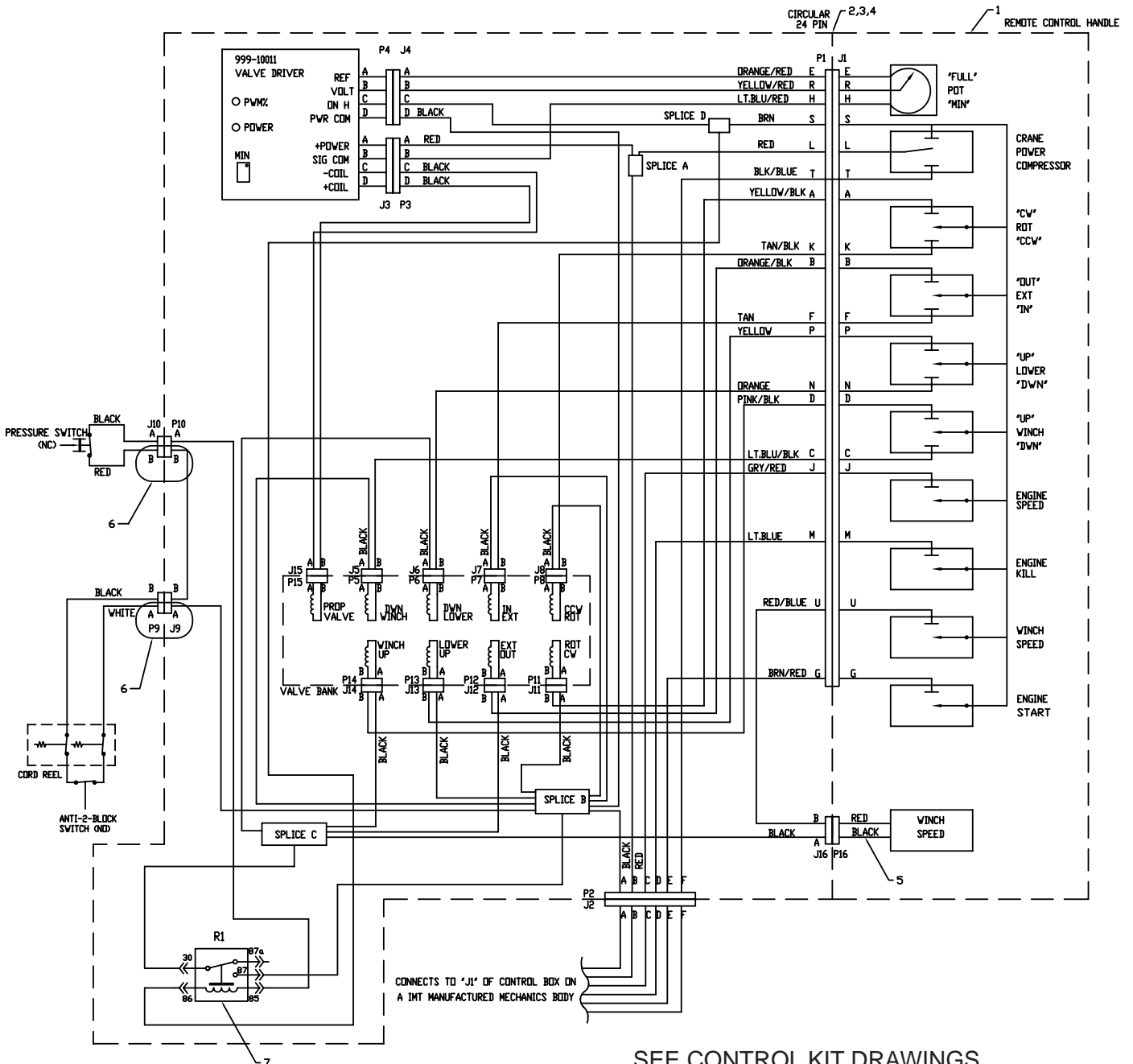

SEE CONTROL KIT DRAWINGS FOR WIRE ROUTINGS.

SECTION 4. GENERAL REFERENCE

INSPECTION CHECKLIST	3
WIRE ROPE INSPECTION	7
HOOK INSPECTION	7
HOLDING VALVE INSPECTION	8
ANTI-TWO BLOCKING DEVICE INSPECTION	8
TORQUE DATA CHART - DOMESTIC	9
TORQUE DATA CHART - METRIC	10
TURNTABLE BEARING FASTENER TIGHTENING SEQUENCE	11
TURNTABLE BEARING INSPECTION FOR REPLACEMENT	12

NOTICE	
The user of this form is responsible in determining that these inspections satisfy all applicable regulatory requirements	
OWNER/COMPANY	
CONTACT PERSON	
CRANE MAKE & MODEL	
CRANE SERIAL NUMBER	
UNIT I.D. NUMBER	
LOCATION OF UNIT	

<i>Inspection Checklist</i>	
CRANES	
TYPE OF INSPECTION (check one) <input type="checkbox"/> DAILY (if deficiency found) <input type="checkbox"/> QUARTERLY <input type="checkbox"/> MONTHLY <input type="checkbox"/> ANNUAL	
DATE INSPECTED	
HOUR METER READING (if applicable)	
INSPECTED BY (print)	
SIGNATURE OF INSPECTOR	

REV. 6-18-99

1

TYPE OF INSPECTION
NOTES:
Daily and monthly inspections are to be performed by a "designated" person, who has been selected or assigned by the employer or the employer's representative as being competent to perform specific duties.
Quarterly and annual inspections are to be performed by a "qualified" person who, by possession of a recognized degree in an applicable field or certificate of professional standing, or who, by extensive knowledge, training and experience has successfully demonstrated the ability to solve or resolve problems related to the subject matter and work.
One hour of normal crane operation assumes 20 complete cycles per hour. If operation exceeds 20 cycles per hour, inspection frequency should be increased accordingly.
Consult Operator / Service Manual for additional inspection items, service bulletins and other information.
Before inspecting and operating crane, crane must be set up away from power lines and leveled with outriggers fully extended.

DAILY (D): Before each day of operation, those items designated with a **(D)** must be inspected. This inspection need not be recorded unless a deficiency (**X**) is found. If the end user chooses to record all daily inspections and those daily inspections include the monthly inspection requirements, there would be no need for a separate monthly inspection.

MONTHLY (M): Monthly inspections or 100 hours of normal operation (which ever comes first) includes all daily inspections plus items designated with an **(M)**. This inspection must be recorded.

QUARTERLY (Q): Every three to four months or 300 hours of normal operation (which ever comes first) includes all daily and monthly inspection items plus items designated with a **(Q)**. This inspection must be recorded.

ANNUAL (A): Each year or 1200 hours of normal operation (which ever comes first) includes all items on this form which encompasses daily, monthly and quarterly inspections plus those items designated by **(A)**. This inspection must be recorded.

FREQUENCY	ITEM	KEY	✓ = SATISFACTORY ✗ = DEFICIENCY (must be corrected prior to operation)	R = RECOMMENDATION (should be considered for corrective action) NA = NOT APPLICABLE	STATUS ✓, ✗, R, NA
			INSPECTION DESCRIPTION		
D	1	Labels	All load charts, safety & warning labels, & control labels are present and legible.		
D	2		Check all safety devices for proper operation.		
D	3	Controls	Control mechanisms for proper operation of all functions, leaks & cracks.		
D	4	Station	Control and operator's station for dirt, contamination by lubricants, & foreign materials.		
D	5	Hyd System	Hydraulic system (hoses, tubes & fittings) for leakage & proper oil level.		
D	6	Hook	Presence & proper operation of hook safety latches.		
D	7	Rope	Proper reeving of wire rope on sheaves & winch drum.		
D	8	Pins	Proper engagement of all connecting pins & pin retaining devices.		
D	9	General	Overall observation of crane for damaged or missing parts, cracked welds & presence of safety covers.		
D	10	Operation	During operation, observe crane for abnormal performance, unusual wear (loose pins, wire rope damage, etc.). If observed, discontinue use & determine cause & severity of hazard.		
D	11	Remote Ctrl	Operate remote control devices to check for proper operation.		
D	12	Electrical	Operate all lights, alarms, etc. to check for proper operation.		
D	13	Anti 2-Blocking	Operate anti 2-blocking device to check for proper operation.		
D	14		Other		
D	15		Other		

<i>Inspection Checklist</i>	CRANES	2
-----------------------------	---------------	----------

FREQUENCY	ITEM	KEY	✓ = SATISFACTORY ✗ = DEFICIENCY (must be corrected prior to operation)	R = RECOMMENDATION (should be considered for corrective action) NA = NOT APPLICABLE	STATUS
			INSPECTION DESCRIPTION	✓, ✗, R, NA	
M	16	Daily	All daily inspection items.		
M	17	Cylinders	Visual inspection of cylinders for leakage at rod, fittings & welds. Damage to rod & case.		
M	18	Valves	Holding valves for proper operation.		
M	19	Valves	Control valve for leaks at fittings & between sections.		
M	20	Valves	Control valve linkages for wear, smoothness of operation & tightness of fasteners.		
M	21	General	Bent, broken or significantly rusted/corroded parts.		
M	22	Electrical	Electrical systems for presence of dirt, moisture & frayed wires.		
M	23	Structure	All structural members for damage.		
M	24	Welds	All welds for breaks & cracks.		
M	25	Pins	All pins for proper installation & condition.		
M	26	Hardware	All bolts, fasteners & retaining rings for tightness, wear & corrosion		
M	27	Wear Pads	Presence of wear pads.		
M	28	Pump & Motor	Hydraulic pumps & motors for leakage at fittings, seals & between sections.		
M	29	PTO	Transmission/PTO for leakage, abnormal vibration & noise.		
M	30	Hyd Fluid	Quality of hydraulic fluid and for presence of water.		
M	31	Hyd Lines	Hoses & tubes for leakage, abrasion damage, blistering, cracking, deterioration, fitting leakage & secured properly.		
M	32	Hook	Load hook for abnormal throat distance, twist, wear & cracks.		
M	33	Rope	Condition of load line.		
M	34	Manual	Presence of operator's manuals with unit.		
M	35		Other		
Q	36	Daily	All daily inspection items.		
Q	37	Monthly	All monthly inspection items.		
Q	38		Condition of wear pads		
Q	39	Rotation Sys	Rotation bearing for proper torque of all accessible mounting bolts.		
Q	40	Hardware	Base mounting bolts for proper torque.		
Q	41	Structure	All structural members for deformation, cracks & corrosion.		
	42		● Base		
	43		● Outrigger beams & legs		
	44		● Mast		
	45		● Inner boom		
	46		● Outer boom		
	47		● Extension(s)		
	48		● Jib boom		
	49		● Jib extension(s)		
	50		● Other		
Q	51	Hardware	Pins, bearings, shafts, gears, rollers, & locking devices for wear, cracks, corrosion & distortion.		
	52		● Rotation bearing(s)		
	53		● Inner boom pivot pin(s) & retainer(s)		
	54		● Outer boom pivot pin(s) & retainer(s)		
	55		● Inner boom cylinder pin(s) & retainer(s)		
	56		● Outer boom cylinder pin(s) & retainer(s)		
	57		● Extension cylinder pin(s) & retainer(s)		
	58		● Jib boom pin(s) & retainer(s)		
	59		● Jib cylinder pin(s) & retainer(s)		
	60		● Jib extension cylinder pin(s) & retainer(s)		
	61		● Boom tip attachments		
	62		● Other		
Q	63	Hyd Lines	Hoses, fittings & tubing for proper routing, leakage, blistering, deformation & excessive abrasion.		
	64		● Pressure line(s) from pump to control valve		
	65		● Return line(s) from control valve to reservoir		
	66		● Suction line(s) from reservoir to pump		
	67		● Pressure line(s) from control valve to each function		
	68		● Load holding valve pipe(s) and hose(s)		
	69		● Other		

WIRE ROPE INSPECTION

Wire rope with any of the deficiencies shown below shall be removed and replaced immediately.

- A. Corrosion can be cause for replacement. Any development of corrosion must be noted and monitored closely.
- B. When there are either 3 broken wires in one strand or a total of six broken wires in all strands in any one rope lay.

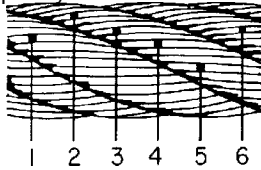

- C. When flat spots on the outer wires appear and those outside wires are less than 2/3 the thickness of the unworn outer wire.

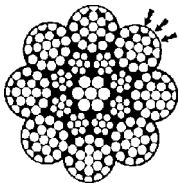

- D. When there is a decrease of diameter indicating a core failure.

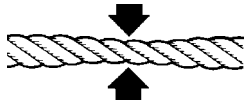

- E. When kinking, crushing, birdcaging or other distortion occurs.

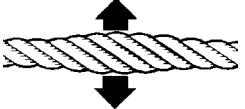

- F. When there is noticeable heat damage (discoloration) of the rope by any means.



- G. When the diameter is reduced from nominal size by 1/32" or more.



- H. If a broken wire protrudes or loops out from the core of the rope.



HOOK INSPECTION

Hooks having any of the listed deficiencies shall be removed from service unless a qualified person approves their continued use and initiates corrective action. Hooks approved for continued use shall be subjected to periodic inspection.

A. DISTORTION

Bending/ Twisting

A bend or twist exceeding 10° from the plane of the unbent hook.

Increased Throat Opening

HOOK WITHOUT LATCH: An increase in throat opening exceeding 15% (Or as recommended by the manufacturer)

HOOK WITH LATCH: An increase of the dimension between a fully-opened latch and the tip section of the hook exceeding 8% (Or as recommended by the manufacturer)

B. WEAR

If wear exceeds 10% of the original sectional dimension. (Or as recommended by the manufacturer)

C. CRACKS, NICKS, GOUGES

Repair of cracks, nicks, and gouges shall be carried out by a designated person by grinding longitudinally, following the contour of the hook, provided that no dimension is reduced more than 10% of its original value. (Or as recommended by the manufacturer) (A qualified person may authorize continued use if the reduced area is not critical.)

D. LATCH

Engagement, Damage & Malfunction

If a latch becomes inoperative because of wear or deformation, and is required for the service involved, it shall be replaced or repaired before the hook is put back into service. If the latch fails to fully close the throat opening, the hook shall be removed from service or "moused" until repairs are made.

E. HOOK ATTACHMENTS & SECURING MEANS

If any indication of distortion, wear, cracks, nicks or gouges are present, unless a qualified person authorizes their use. (Or as recommended by the manufacturer)

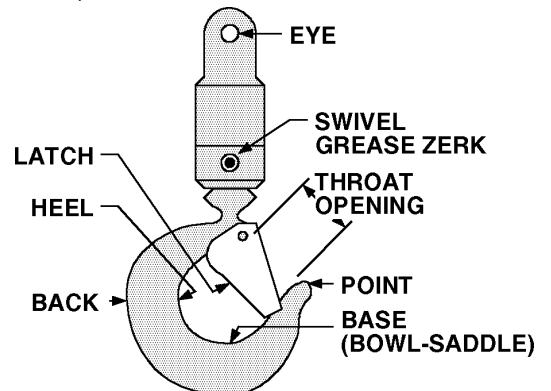

HOLDING VALVE INSPECTION

The cylinders are equipped with holding valves that prevent sudden movement of the cylinder rods in the event of a hydraulic hose or other hydraulic component failure. The valve is checked in the following manner:

1. With a full rated load, extend the cylinder in question and kill the engine.
2. Operate the control valve to retract the cylinder. If the cylinder “creeps”, replace the holding valve. If the cylinder does not “creep”, the valve is serviceable.

ANTI-TWO BLOCKING DEVICE INSPECTION

(See Vol. 1, Operation, Maintenance and Repair for a complete description)



The anti two block system should be checked daily as follows:

1. Examine flexible rod and weight to insure free unrestricted mechanical operation
2. Examine cord for damage, cuts or breaks. Grasp cord and pull to check operation of cord reel. The cord should retract on reel when released.
3. Start vehicle, engage PTO and slowly winch loadline up until anti-two block weight comes in contact with the hook end of the loadline cable. At the moment the weight is fully supported, a marked difference in winch operation should be noted. At this point, the winch up function should become very sluggish or non-functioning and have very little pull capability. Slowly increase truck engine speed while simultaneously actuating the winch up function. The winch characteristics should remain sluggish with little or no tensioning of the cable. If operation other than as described occurs, stop immediately and investigate. Failure to do so will risk damage to the cable or the crane. If all is well at this point, actuate the boom extend function slowly, and gradually increase to full actuation. Once again the function should be sluggish or non-existent with no tightening of the winch cable. If operation other than described occurs, stop immediately and reverse the function.

The final check involves actuating both the winch up and extend functions together and checking for proper operation of the anti two blocking circuit. Once again, start slowly and stop if it appears the cable is being tensioned.

If the anti two block function appears to be functioning normally, winch the cable down until the sensing weight swings free.

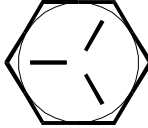
COARSE THREAD BOLTS

SIZE (DIA-TPI)	BOLT DIA (INCHES)	TIGHTENING TORQUE			
		 SAE J429 GRADE 5		 SAE J429 GRADE 8	
		PLAIN (FT-LBS)	PLATED (FT-LBS)	PLAIN (FT-LBS)	PLATED (FT-LBS)
5/16-18	0.3125	17	13	25	18
3/8-16	0.3750	31	23	44	33
7/16-14	0.4375	49	37	70	52
1/2-13	0.5000	75	57	105	80
9/16-12	0.5625	110	82	155	115
5/8-11	0.6250	150	115	220	160
3/4-10	0.7500	265	200	375	280
7/8-9	0.8750	395	295	605	455
1-8	1.0000	590	445	910	680
1 1/8-7	1.1250	795	595	1290	965
1 1/4-7	1.2500	1120	840	1815	1360
1 3/8-6	1.3750	1470	1100	2380	1780
1 1/2-6	1.5000	1950	1460	3160	2370

When using the torque data in the charts above, the following rules should be observed.

1. Bolt manufacturer’s particular specifications should be consulted when provided.
2. Flat washers of equal strength must be used.
3. All torque measurements are given in foot-pounds. To convert to inch-pounds, multiply by 12.
4. Torque values specified are for bolts with residual oils or no special lubricants applied. If special lubricants of high stress ability, such as Never-Seez compound graphite and oil, molybdenum disulphite, colloidal copper or white lead are applied, multiply the torque values in the charts by the factor .90. The use of Loctite does not affect the torque values listed above.
5. Torque values for socket-head capscrews are the same as for Grade 8 capscrews.

WARNING

Anytime a gear-bearing bolt is removed, it must be replaced with a new bolt of the identical grade and size. Once a bolt has been torqued to 75% of its proof load and then removed, the torque coefficient may no longer be the same as when the bolt was new thus giving indeterminate clamp loads after torquing. Failure to replace gear-bearing bolts may result in bolt failure due to metal fatigue causing serious injury or DEATH.

TORQUE DATA CHART - DOMESTIC

FINE THREAD BOLTS

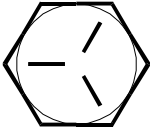
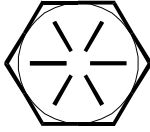
SIZE (DIA-TPI)	BOLT DIA (INCHES)	TIGHTENING TORQUE			
		 SAE J429 GRADE 5		 SAE J429 GRADE 8	
		PLAIN (FT-LBS)	PLATED (FT-LBS)	PLAIN (FT-LBS)	PLATED (FT-LBS)
5/16-24	0.3125	19	14	27	20
3/8-24	0.3750	35	26	49	35
7/16-20	0.4375	55	41	78	58
1/2-20	0.5000	90	64	120	90
9/16-18	0.5625	120	90	170	130
5/8-18	0.6250	170	130	240	180
3/4-16	0.7500	300	225	420	315
7/8-11	0.8750	445	325	670	500
1-12	1.0000	645	485	995	745
1 1/8-12	1.1250	890	670	1445	1085
1 1/4-12	1.2500	1240	930	2010	1510
1 3/8-12	1.3750	1675	1255	2710	2035
1 1/2-12	1.5000	2195	1645	3560	2670

COARSE THREAD BOLTS

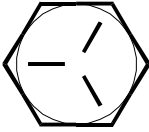
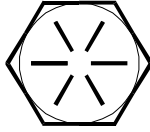
SIZE (DIA-TPI)	BOLT DIA (INCHES)	TIGHTENING TORQUE			
		 SAE J429 GRADE 5		 SAE J429 GRADE 8	
		PLAIN (FT-LBS)	PLATED (FT-LBS)	PLAIN (FT-LBS)	PLATED (FT-LBS)
5/16-18	0.3125	17	13	25	18
3/8-16	0.3750	31	23	44	33
7/16-14	0.4375	49	37	70	52
1/2-13	0.5000	75	57	105	80
9/16-12	0.5625	110	82	155	115
5/8-11	0.6250	150	115	220	160
3/4-10	0.7500	265	200	375	280
7/8-9	0.8750	395	295	605	455
1-8	1.0000	590	445	910	680
1 1/8-7	1.1250	795	595	1290	965
1 1/4-7	1.2500	1120	840	1815	1360
1 3/8-6	1.3750	1470	1100	2380	1780
1 1/2-6	1.5000	1950	1460	3160	2370

When using the torque data in the charts above, the following rules should be observed.

1. Bolt manufacturer's particular specifications should be consulted when provided.
2. Flat washers of equal strength must be used.
3. All torque measurements are given in foot-pounds. To convert to inch-pounds, multiply by 12.
4. Torque values specified are for bolts with residual oils or no special lubricants applied.
If special lubricants of high stress ability, such as Never-Seez compound graphite and oil, molybdenum disulphite, colloidal copper or white lead are applied, multiply the torque values in the charts by the factor .90. The use of Loctite does not affect the torque values listed above.
5. Torque values for socket-head capscrews are the same as for Grade 8 capscrews.

WARNING

Anytime a gear-bearing bolt is removed, it must be replaced with a new bolt of the identical grade and size. Once a bolt has been torqued to 75% of its proof load and then removed, the torque coefficient may no longer be the same as when the bolt was new thus giving indeterminate clamp loads after torquing. Failure to replace gear-bearing bolts may result in bolt failure due to metal fatigue causing serious injury or DEATH.

TORQUE DATA CHART - METRIC

FINE THREAD BOLTS

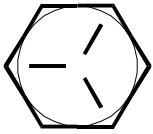
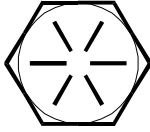
SIZE (DIA-TPI)	BOLT DIA (INCHES)	TIGHTENING TORQUE			
		 SAE J429 GRADE 5		 SAE J429 GRADE 8	
		PLAIN (KG-M)	PLATED (KG-M)	PLAIN (KG-M)	PLATED (KG-M)
5/16-24	0.3125	3	2	4	3
3/8-24	0.3750	5	4	7	5
7/16-20	0.4375	8	6	11	8
1/2-20	0.5000	12	9	17	12
9/16-18	0.5625	17	12	24	18
5/8-18	0.6250	24	18	33	25
3/4-16	0.7500	41	31	58	44
7/8-11	0.8750	62	45	93	69
1-12	1.0000	89	67	138	103
1 1/8-12	1.1250	123	93	200	150
1 1/4-12	1.2500	171	129	278	209
1 3/8-12	1.3750	232	174	375	281
1 1/2-12	1.5000	304	228	492	369

COARSE THREAD BOLTS

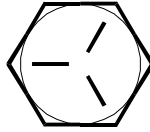
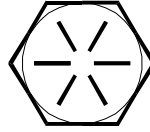
SIZE (DIA-TPI)	BOLT DIA (INCHES)	TIGHTENING TORQUE			
		 SAE J429 GRADE 5		 SAE J429 GRADE 8	
		PLAIN (KG-M)	PLATED (KG-M)	PLAIN (KG-M)	PLATED (KG-M)
5/16-18	0.3125	2	2	3	2
3/8-16	0.3750	4	3	6	5
7/16-14	0.4375	7	5	10	7
1/2-13	0.5000	10	8	15	11
9/16-12	0.5625	15	11	21	16
5/8-11	0.6250	21	16	30	22
3/4-10	0.7500	37	28	52	39
7/8-9	0.8750	55	41	84	63
1-8	1.0000	82	62	126	94
1 1/8-7	1.1250	110	82	178	133
1 1/4-7	1.2500	155	116	251	188
1 3/8-6	1.3750	203	152	329	246
1 1/2-6	1.5000	270	210	438	328

When using the torque data in the charts above, the following rules should be observed.

1. Bolt manufacturer's particular specifications should be consulted when provided.
2. Flat washers of equal strength must be used.
3. All torque measurements are given in kilogram-meters.
4. Torque values specified are for bolts with residual oils or no special lubricants applied.
If special lubricants of high stress ability, such as Never-Seez compound graphite and oil, molybdenum disulphite, colloidal copper or white lead are applied, multiply the torque values in the charts by the factor .90. The use of Loctite does not affect the torque values listed above.
5. Torque values for socket-head capscrews are the same as for Grade 8 capscrews.

WARNING

Anytime a gear-bearing bolt is removed, it must be replaced with a new bolt of the identical grade and size. Once a bolt has been torqued to 75% of its proof load and then removed, the torque coefficient may no longer be the same as when the bolt was new thus giving indeterminate clamp loads after torquing. Failure to replace gear-bearing bolts may result in bolt failure due to metal fatigue causing serious injury or DEATH.

TURNTABLE BEARING INSPECTION FOR REPLACEMENT

Before a bearing is removed from a crane for inspection, one of the following conditions should be evident:

1. Metal particles present in the bearing lubricant.
2. Increased drive power required to rotate the crane.
3. Noise emitting from the bearing during crane rotation.
4. Rough crane rotation.
5. Uneven or excessive wear between the pinion gear and turntable gear.

If none of the above conditions exists, the bearing is functioning properly and need not be replaced. But, if one or more of the above conditions exists, inspection may be required. Limits are measured in "TILT" which is dependent on the internal clearances of the bearing. TILT is the most practical determination of a bearings internal clearance once mounted on a crane.

Periodic readings indicating a steady increase in TILT may be an indicator of bearing wear. Note that a bearing found to have no raceway cracks or other structural irregularities should be reassembled and returned to service.

TEST PROCEDURE

STEP 1.

With the crane horizontal and fully extended, measure between the top and bottom mounting surfaces of the turntable bearing (A1), using a dial indicator for accuracy.

STEP 2.

Reverse the load by applying minimal downward pressure on the boom while the boom is in the boom support or on a solid surface. Again measure A2.

STEP 3.

Subtract A1 from A2 to determine tilt and compare the result with the accompanying chart.

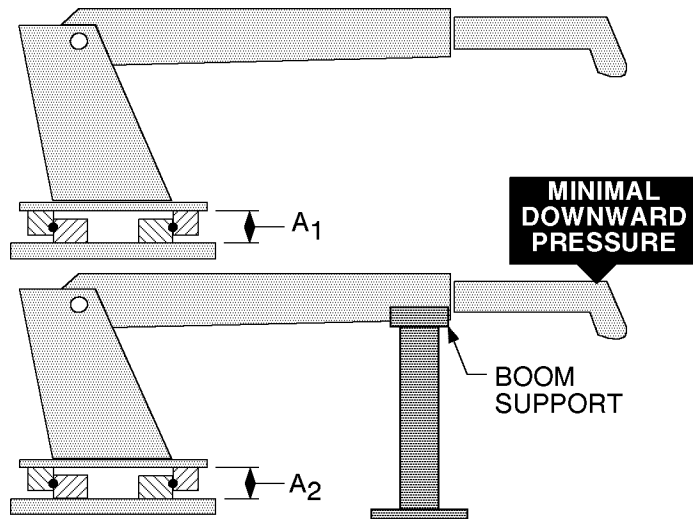

COMPARISON CHART - MODEL TO MEASURED TILT DIMENSION

NOTE	IMT CRANE, LOADER OR TIREHAND MODEL	1007 1014 1014A 1015 2015/2020 2109 3000 3816/3820 3016/3020 421/425 4300 5016/5020 6016/6020 TH7 BODY ROT'N TH1449 BODY ROT'N TH15B CLAMP TH2551B CLAMP TH2557A CLAMP	5200 5200R 5217 5800 7020 7025 7200 7415 9000 TH10 BODY ROT'N TH14 BODY ROT'N	16000 32018 32030 T30 T40	9800 12916 13031 13034 14000 15000 18000 20017 H1200 H1200RR T50 TH2551B BODY ROT'N TH2557B BODY ROT'N TH2557A BODY ROT'N
THE FIGURES LISTED IN THIS CHART ARE SERVICE GUIDELINES AND DO NOT, IN THEMSELVES, REQUIRE THAT THE BEARING BE INSPECTED.					
IF THERE IS REASON TO SUSPECT AN EXCESS OF BEARING WEAR AND THE MEASURED TILT DIMENSION EXCEEDS THE DIMENSION LISTED, REMOVE THE BEARING FOR INSPECTION.					
	BALL DIA. (REF)	.875" (22mm)	1.00" (25mm)	1.18"-1.25" (30-32mm)	1.75" (44mm)
	TILT DIM. (A₁-A₂)	.060" (1.524mm)	.070" (1.778mm)	.075" (1.905mm)	.090" (2.286mm)

20000710

The information within this manual has been compiled and checked but errors do occur. To provide our customers with a method of communicating those errors we have provided the Manual Change Request form below. In addition to error reporting, you are encouraged to suggest changes or additions to the manual which would be of benefit to you. We cannot guarantee that these additions will be made but we do promise to consider them. When completing the form, please write or print clearly. Submit a copy of the completed form to the address listed below.

MANUAL CHANGE REQUEST

DATE	PRODUCT MANUAL	MANUAL PART NO.
SUBMITTED BY		
COMPANY		
ADDRESS		
CITY, STATE, ZIP		
TELEPHONE		

ERROR FOUND

LOCATION OF ERROR (page no.): _____

DESCRIPTION OF ERROR: _____

ERROR FOUND

DESCRIPTION OF ADDITION: _____

REASON FOR ADDITION: _____

MAIL TO:
IOWA MOLD TOOLING CO., INC.
BOX 189
GARNER, IA 50438-0189
ATTN: Technical Publications

This parts manual is provided to the user to assist in servicing the equipment. It is the property of Iowa Mold Tooling Co., Inc. and, as such, may not be reproduced either whole or in part, whether by chemical, electrostatic, mechanical or photographic means without the expressed written permission of an officer of Iowa Mold Tooling Co., Inc. One manual is provided with each piece of new equipment and additional manuals may be obtained at a nominal price. Your distributor may have access to this manual through the IMT web site at www.IMT.com.

IOWA MOLD TOOLING CO., INC.
BOX 189, GARNER, IA 50438-0189
TEL: 641-923-3711

www.imt.com