

Specifications

Lattice Boom Truck Crane

HC-228H

125 Ton (113 metric ton)

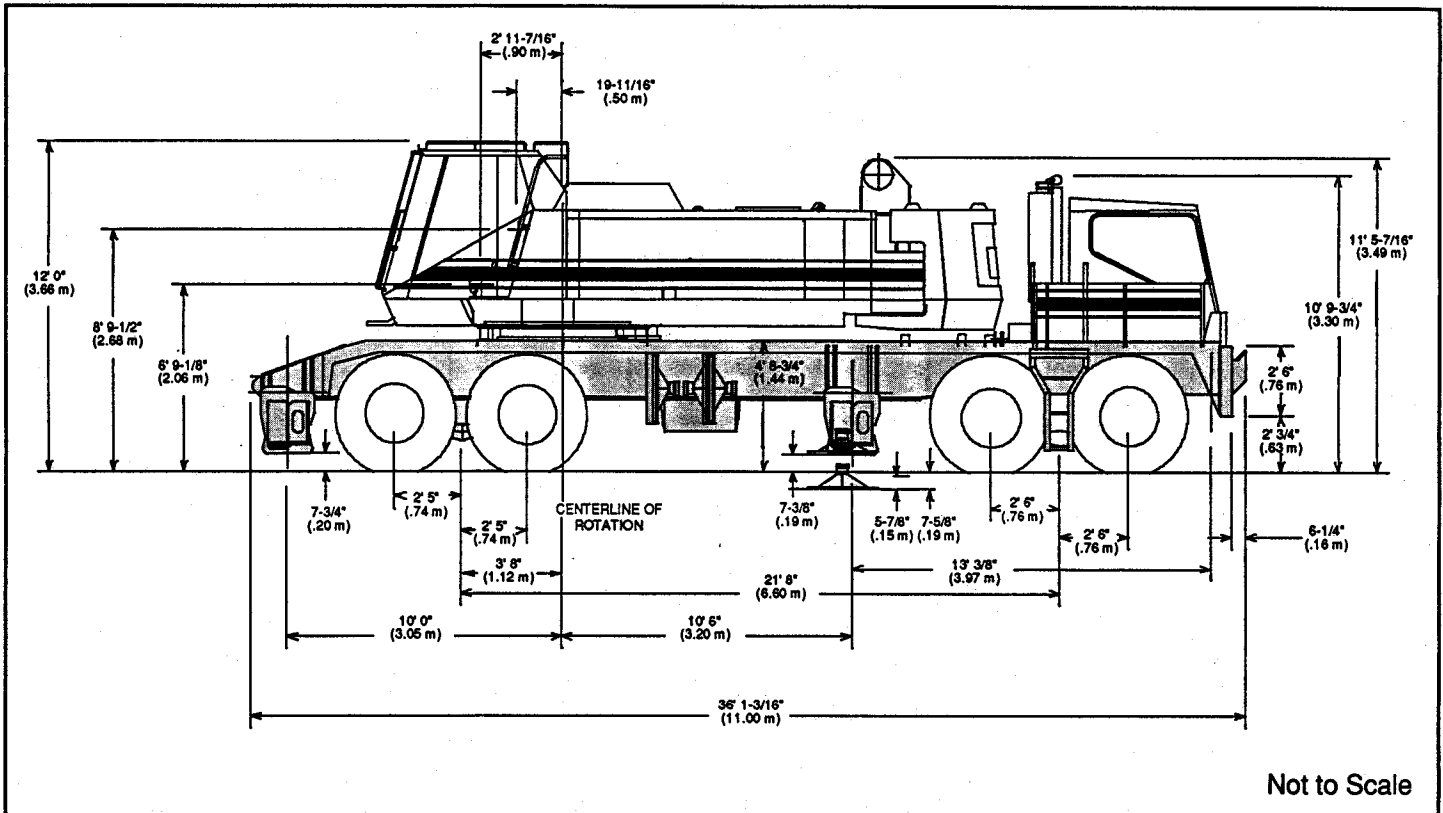

Not to Scale

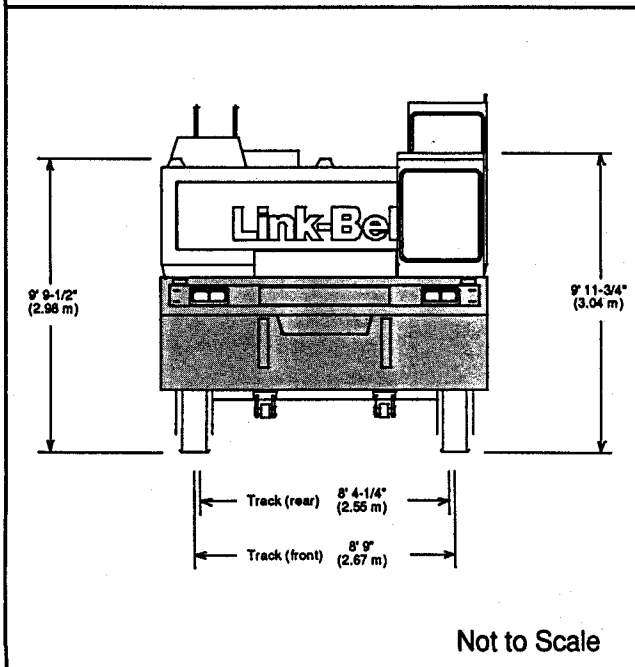

Not to Scale

General dimensions	feet	meters
Overall width, outriggers extended, (over floats)	23' 6"	7.16
Overall width, outriggers extended, (C/L of jacks)	21' 0"	6.40
Overall width, outriggers retracted	11' 0"	3.35
Vehicle clearance circle over outside of front bumper	104' 2"	31.73
Vehicle clearance circle over outside of front bumper counterweight	105' 10"	32.25
Minimum ground clearance (at bottom of front bogie beams)	11"	.28
Counterweight tailswing (at corners)	15' 11"	4.85
Overall cab width (upper)	11' 0"	3.35
Radius of boom hinge pin	35'-7/16"	.90
Height of boom hinge pin	6' 9"	1.98
Ground clearance under counterweight	5' 2"	1.58

GENERAL INFORMATION ONLY

Axle Loads — Calculated

Based on standard HC-228H revolving upperstructure equipped with Isuzu engine, power load lowering on front and rear load hoist drums, no counterweight, mounted on 260" (6.60 m) wheelbase, 8x4 drive carrier, 11' 0" (3.35 m) wide, equipped with DD 8V-92 TAC DDEC diesel engine, front center hydraulic jack, and full fuel.	Basic Machine Gross Weight		Upper facing front				Upper facing rear				
	**	lbs.	kg	lbs.	kg	lbs.	kg	lbs.	kg	lbs.	kg
	A	34,340	15 577	-510	-231	34,850	15 808	12,130	5 502	22,210	10 074
B	42,430	19 246	20,745	9 410	21,685	9 836	20,745	9 410	21,685	9 836	
C	76,770	34 823	20,235	9 179	56,535	25 644	32,875	14 912	43,895	19 911	
Adjust axle weights for adding following components	Component Weights		Front axle		Rear axle		Front axle		Rear axle		
	lbs.	kg	lbs.	kg	lbs.	kg	lbs.	kg	lbs.	kg	
Upperstructure —											
Add for boomhoist rope and live mast :											
folded to rear of upper	5,590	2 536	-2,455	1 114	8,045	3 649	4,345	1 971	1,245	565	
-or-	-or-	-or-	-or-	-or-	-or-	-or-	-or-	-or-	-or-	-or-	
folded forward of boomfoot	5,590	2 536	3,470	1 574	2,120	962	-1,575	-714	7,165	3 250	
Rear drum wire rope —1,000' (305 m) of 1" (25 mm) Type "P"	770	349	-115	-52	885	401	375	170	395	179	
Front drum wire rope —1,000' (305 m) of 1-1/8" (29 mm) Type "N"	1,350	612	50	23	1,300	590	410	186	940	426	
Counterweight "A"	23,000	10 433	-10,580	-4 809	33,580	15 232	18,365	8 330	4,635	2 102	
-or-	-or-	-or-	-or-	-or-	-or-	-or-	-or-	-or-	-or-	-or-	
Counterweight "AB"	42,330	19 201	20,635	9 360	62,965	28 561	34,960	15 858	7,370	3 343	
Carrier—											
Front outrigger box, beams and jacks	7,600	3 447	4,970	2 254	2,630	1 193	4,970	2 254	2,630	1 193	
Rear outrigger box, beams and jacks	7,600	3 447	-2,220	-1 007	9,820	4 454	-2,220	-1 007	9,820	4 454	
Hydraulic pin pullers	430	195	80	36	350	159	80	36	350	159	
5 jack floats	810	368	315	143	495	225	315	143	495	225	
Bumper counterweight "A"	13,500	6 124	17,810	8 079	-4,310	-1 955	17,810	8 079	-4,310	-1 955	
Cummins N14-460E diesel engine	n/a	n/a	n/a	n/a	n/a	n/a	n/a	n/a	n/a	n/a	
Attachment—											
20' (6.10 m) tubular boom base section with hydraulic boomfoot pins — horizontal	3,380	1 533	-	-	-	-	-1,465	-665	4,845	2 198	

** A—Upper, B—Carrier C—Total

GENERAL INFORMATION ONLY

Carrier

■ Type

260" (6.60 m) wheelbase, 8 x 4 drive.
11' 0" (3.35 m) wide.

Frame — Main members heat treated alloy steel, triple-box construction. Machined mounting surface for turntable bearing. Towing shackles front and rear.

Turntable bearing — Inner race, with integral internal tooth swing (ring) gear, bolted to machined surface on carrier deck.

■ Outriggers

Full width, double box, front and rear pin connected to carrier frame. Hydraulically operated beams and jack cylinders individually controlled from each side of carrier. Hydraulic power supplied by belt-driven hydraulic pump. Check valve at each jack cylinder.

Optional - Hydraulic outrigger box pin puller.

Front center hydraulic jack with float

Standard- Single hydraulic jack, with float, mounted at front of the carrier. Jack/float assembly required for handling 360° swing ed capacities.

Floats — Low profile, alloy steel; 30" (0.76 m) square base.

Trailer hitch — *Optional* - Includes air and electric connections at rear of carrier for trailer lights and air brakes.

■ Axles

Front- Tubular; bogie beam mounted tandem axles, single wheels. 105" (2.67 m) track.

Rear- Planetary type, bogie mounted tandem axles, dual wheels. 100" (2.54 m) track.

Suspension — Hendrickson rubber bushed front and bronze bushed rear equalizer beams with rubber bushed torque rods.

Wheels and rims — Front; disc-type. Rear, integral with planetary hubs.

Tag axle — *Optional* - Consult factory.

■ Tires

Single tires on front axles, dual tires on rear axles.

Standard — Front - 14.0 x24J (18-ply rating) transport type tread.

Rear - 14.0 x24L (20-ply rating) transport type tread.

Optional - Consult factory.

■ Brakes

Air brake system

Service — Dual circuit with modulated emergency brakes. Bendix dual circuit 8 wheel air brakes with service chambers on 4 front wheels and spring applied, air released emergency, parking, service chambers on 4 rear wheels. Air dryer standard.

Size

Rear wheels; 20-1/4" x 7" (0.51 x 0.18 m)

Front wheels; 16-1/2" x 6" (0.42 x 0.15 m)

Steering — Sheppard full integral hydraulic power with one master gear, one slave gear and one hydraulic pump for each axle. Steering mounted high on side of frame to minimize exposure to hazards. Separate master and slave for each axle eliminates transfer of steering force from entire system into one axle which could overload and damage linkage. Steering wheel is mechanically connected to axles to allow steering (with increased steering input effort) in the event of hydraulic system failure. Multiple pumps minimize possibility of total hydraulic system failure and only require increase in steering input effort sufficient to compensate for that portion of system that failed. High speed, high power system to maximize maneuverability both on the job site and on the road.

■ Engines

Diesel; 12/24-volt alternator, starter, pressure lubrication, hydraulic pump, dry type air cleaner, and air compressor.

Standard - Detroit Diesel 8V-92 TAC diesel, 8 cylinder. See page 4 for details.

Optional - Cummins N14-460E (available 1991). See page 4 for details.

Clutch — Lipe-Rollway 15-1/2" (0.39 m) 2 plate, dry disc.

Transmissions

Main — Eaton RTX 14708LL; ten speeds forward, three reverse.

Auxiliary — Spicer P-1241-C; 4-speed, midship mounting.

■ Bumper Counterweight

"A" counterweight — 13 500 lbs.

(6 124 kg).

■ Carrier Cab

One-man, offset, fully enclosed. Air suspension mounted bucket seat with seat belt. Noise absorbing insulation with vinyl covering, sound reduction headliner, rubber floor mat; isolated from engine compartment, rubber mounted for sound level reduction. Instrument panel and dash includes speedometer, odometer, voltmeter, and gauges for fuel, engine temperature, air and oil pressures. Low air pressure warning buzzer, key locking switch, starter, tachometer, fire extinguisher, heater and defroster, 2-speed electric windshield wiper, and windshield washer. Tilt and telescope steering column.

■ Electrical System

12-volt; including dual sealed beam headlights, directional signals with 4-way flashing system, stop and tail lights, clearance lights, horn, lighting of instrument panel, dome light, headlight dimmer switch, and four 12-volt, group 31 batteries. Individual switches provide circuit control for hydraulic outrigger solenoid valves; one control station on each side of carrier.

■ Fuel Tank

One 85 gallon (322 liter) capacity tank; side mounted on carrier frame.

Standard auxiliary equipment — West Coast type rear view mirrors, lug wrench, 2-way reading bubble levels. High pressure lube fittings at all bearing points. Hand grab rails, carrier deck access ladder, back-up alarm, skid-resistant finish on carrier deck.

GENERAL INFORMATION ONLY

Engine Specifications	Detroit Diesel 8V-92 TAC DDEC	Cummins N14-460E
Number of cylinders	8	6
Bore	4.84" (0.12 m)	5.5" (0.14 m)
Stroke	5" (0.13 m)	6" (0.15 m)
Piston Displacement	736 cu. in. (12 061 cm ³)	855 cu. in. (14 013 cm ³)
Max. brake h.p. @ r.p.m.	450 (335.56 kw) @ 2,100	460 (343.02 kw) @ 1,700 or 350 (261.00 kw) @ 2,100
Governed load speed r.p.m.	2,100	2,100
Peak torque @ r.p.m.	1,425 ft. lbs. (1 932 j) @ 1,200	1,550 ft. lbs. (2 102 j) @ 1,200
Electrical system	12/24-volt charging/24-volt starting	12/24-volt charging/24-volt starting
Batteries	Four 12-volt	Four 12-volt
Air compressor	Bendix TU-FLO 1000, 24 cfm (68 m ³ /min)	Cummins 30 cfm (85 m ³ /min)

Carrier Speeds

Main — Eaton RTX 14708LL			Auxiliary — Spicer P-1241-C							
			4th (.81)		3rd (1.00)		2nd (1.24)		1st (2.37)	
Gear		Ratio	m.p.h.	km/hr	m.p.h.	km/hr	m.p.h.	km/hr	m.p.h.	km/hr
High	8th	.74	48.0	77.2	47.4	76.3	38.2	61.5	20.0	32.2
	7th	1.00	43.2	69.5	35.1	56.5	28.3	45.5	14.8	23.8
	6th	1.36	31.8	51.2	25.8	41.5	20.8	33.5	10.9	17.5
	5th	1.83	23.6	38.0	19.2	30.9	15.5	24.9	8.1	13.0
Low	4th	2.53	17.1	27.5	13.9	22.4	11.2	18.0	5.9	9.5
	3rd	3.40	12.7	20.4	10.3	16.6	8.3	13.4	4.4	7.1
	2nd	4.63	9.3	15.0	7.6	12.2	6.1	9.8	3.2	5.1
	1st	6.24	6.9	11.1	5.6	9.0	4.5	7.2	2.4	3.9
	L	9.42	4.6	7.4	3.7	6.0	3.0	4.8	1.6	2.6
Deep Reduction	LL	14.56	3.0	4.8	2.4	3.9	1.9	3.1	1.0	1.6
Hi Rev.	Rev.	2.89	15.0	24.1	12.1	19.5	9.8	15.8	5.1	8.2
Lo Rev.	Rev.	9.85	4.4	7.1	3.6	5.8	2.9	4.7	1.5	2.4
Deep Reduction	Rev.	15.22	2.8	4.5	2.3	3.7	1.9	3.1	1.0	1.6
Deep Reduction @ 1,200 rpm	LL	14.56	1.7	2.7	1.4	2.3	1.1	1.8	.6	1.0
Deep Reduction @ 1,200 rpm	Rev.	15.22	1.6	2.6	1.3	2.1	1.0	1.6	.6	1.0

Turning Ability

Turning circle diameter	Curb clearance circle diameter	Vehicle clearance circle diameter	
		Over outside of front bumper	Over outside of front bumper counterweight "A"
Centerline of outer front tire	Outside of outer front tire		
98' 6" (30.02 m)	99' 10" (30.43 m)	104' 2" (31.75 m)	105' 10" (32.26 m)

GENERAL INFORMATION ONLY

HC-228H Load Hoisting Performance

Available line speed and line pull - based on ISUZU 6SA1T at 2100 rpm full load speed.

Line pulls are not based on wire rope strength. See wire rope chart for maximum permissible single part of line working loads.

Front and Rear Drum: Line speeds and pulls

16-3/4" (.43 m) Root Dia. - 7/8" (22 mm) dia. rope													
Single line pull		First layer speed				Fourth layer speed				Seventh layer speed			
		Front Drum		Rear Drum		Front Drum		Rear Drum		Front Drum		Rear Drum	
lbs	kgs	fpm	m/min	fpm	m/min	fpm	m/min	fpm	m/min	fpm	m/min	fpm	m/min
1,000	454	224	68	363	111	291	89	471	144	357	109	579	176
5,000	2 268	224	68	363	111	291	89	471	144	357	109	579	176
10,000	4 536	224	68	332	101	291	89	341	104	331	101	353	108
15,000	6 804	219	67	233	71	227	69	238	73	233	71	-	-
20,000	9 072	171	52	180	55	176	54	-	-	180	55	-	-
25,000	9 979	140	43	-	-	140	43	-	-	140	43	-	-

Wire rope: size, type and working strength

Wire rope application	Size: diameter		Type	Max permissible load	
	inches	mm		lbs	kg
Boom hoist	7/8	22	W	22,700	10 297
Main load hoist	7/8	22	N	22,700	10 297
Auxiliary hoist	7/8	22	P	13,000	5 896
Boom pendants	1-1/4	32	N	53,200	24 100

GENERAL INFORMATION ONLY

Wire rope: types available

- Type "N" - 6 X 25 (6 X 19 class), filler wire, extra improved plow steel, preformed, independent wire rope center, right lay, regular lay.
- Type "W" - 6 X 26 (6 X 19 class), extra improved plow steel, preformed, independent wire rope center, right lay, alternate lay.
- Type "P" - 19 X 7 non-rotating, extra improved plow steel, preformed, wire strand core.

Upperstructure

Frame

All-welded, precision machined unit;

Fuel tank

76 gallon (290 L) capacity

Power transmission

All functions hydraulically powered allowing positive, precise control, with independent or simultaneous operation of all crane functions.

Engine Specifications

Isuzu 6SA1T with oil filter, oil cooler, air cleaner, fuel filter, water separator, hour meter, tachometer and electrical shutdown.

Number of cylinders	6
Bore and stroke - inch - (mm)	4 - 17/32 X 5 - 5/16 (115 X 135)
Piston displacement - (in ³) - (cm ³)	513 (8413)
Engine rpm at full load speed Hi-idle rpm	2100 2350
Net engine horsepower at full load speed, (HP)	195 (145 kw)
Peak torque - foot pounds - (joule)	513 696
Peak torque - rpm	1400
Electrical system Batteries	24 volt 2 - 12 volt

Hydraulic System

Hydraulic pumps

Two variable displacement piston pumps operating at 4000 PSI powers main drum, auxiliary drum, and boomhoist functions. One fixed displacement gear pump operating at 3000 PSI powers swing functions. One fixed displacement gear pump operating at 1210 PSI powers pilot control system, clutches, brakes and pump controls.

Hydraulic reservoir

78 US gallon (295 L), equipped with sight level gauge.

Relief valves

Each function is equipped with relief valves to protect the circuit from overload or shock.

Hydraulic filtration

Ten micron, full flow line filter furnished in control circuit. All oil is filtered prior to return to sump tank.

Hydraulic motors

Main hoist drum, auxiliary hoist drum, boomhoist, and swing are powered by axial piston motors.

Counterbalance valves

Hoist motors are equipped with counterbalance valves to provide positive load lowering and prevent accidental load drop when hydraulic power is suddenly reduced.

GENERAL INFORMATION ONLY

Principal Operating Functions

Control system

Remote controlled hydraulic servo for main drum and auxiliary drum. Mechanical linkage controls swing. Function speed is proportional to lever movement. Levers are adjustable for operator comfort.

Load hoisting and lowering

Main and auxiliary hoist drums are driven by individual axial piston motors and reduction gearing. Load hoisting or lowering is provided by actuating or reversing a hydraulic motor. Smooth, precise, power load lowering is attained with automatic hydraulic brake. The control lever provides two speeds for hoisting and lowering. Hoisting or lowering speeds are proportional to lever movement.

Load hoist drums

Main (front) and auxiliary (rear) hoist drums are 16-3/4" (.43 m) root diameter grooved for 7/8" (22 mm) wire rope. Mounted on anti-friction bearings.

Drum clutches

Speed-o-Matic® power hydraulic two-shoe clutches; internal expanding, lined shoes. Clutch spiders are splined to shafts; clutch drums are integral with hoist drums.

Load hoist clutches - Front and rear main drums - clutch drums 20" diameter, 5" face width. Swept area is 314 square inches.

Drum brakes

External contracting band type; operated by foot pedal equipped with a locking latch. Operator may select automatic brake mode (spring applied, hydraulically released), which will apply brakes when the hoist control lever is in the neutral position.

Drum rotation indicators

Standard for front and rear drums. Audible-type indicators.

Drum locking pawl

Standard for front and rear drums; electrically actuated and prevents drum rotation in a lowering direction.

Anti two-block system

Standard: A switch mounted on the boom peak activates a buzzer to warn the operator of a two-block condition and simultaneously disengages hoist function while applying the hoist brakes.

Swing system

Independent, hydraulic swing is driven; by an axial piston motor through a gear reduction system.

Swing brake - Spring applied, hydraulically released; controlled by button on swing control lever.

Swing lock - Mechanically controlled, 360° locking mechanism.

Swing speed - 0 to 2.2 r.p.m.

Boomhoist / lowering system

Independent, hydraulic boomhoist is driven by an axial piston motor through a gear reduction system. Boom hoisting or lowering is performed by actuating or reversing the motor.

Boomhoist drum

Single grooved lagging 10-11/16" (.27 m) root diameter.

Boomhoist drum locking pawl

Electrically operated.

Boomhoist brake

Spring applied, hydraulically released, multiple disc type brake. Brake is automatically applied when control lever is in neutral position.

Boomhoist limiting device - Restricts hoisting boom beyond recommended minimum radius.

Electrical system

24 volt negative ground system, with two 12-volt batteries. Standard lighting system includes: two 70 watt headlights mounted on machine front and one interior cab light.

Operator's cab

Full vision, modular compartment with safety glass panels. The completely independent cab is insulated against noise and vibration. Sliding operator's door, swing up roof window. Standard equipment includes: heater, defroster, windshield wiper, dry chemical fire extinguisher, sun visor, bubble-type level, fuel gauge, tachometer, hydraulic temperature gauge, engine oil pressure gauge, coolant temperature gauge and service monitor system.

Machinery cab

Hinged doors (one on right side, two on left side) for machinery access. Equipped with roof-top access ladder, electric warning horn and skid resistant finish on roof.

Catwalks

Standard on operator side. Catwalks remove for reduced travel width.

GENERAL INFORMATION ONLY

■ **Bail**

Pinned to revolving frame. Six sheaves are provided for 14-part boomhoist wire rope reeving. Sheaves mounted on anti-friction bearings, sealed for lifetime lubrication.

■ **Counterweight**

Counterweight "A" – 23,000 lbs. (10 433 kg)

Counterweight "B" – 20,000 lbs. (9 072 kg)

Boom and Jib

■ **Tubular Boom**

Two-piece basic boom 50' (15.24 m) long with open throat top section. Boom 70" (1.77 m) wide, 62" (1.57 m) deep at connections. Alloy steel round tubular cords 4" (0.10 m) outside diameter.

■ **Base Section**

20' (6.10 m) long; boomfeet on 55" (1.40 m) centers.

■ **Boom Extensions**

Available in 10', 20', 30' and 40' (3.05, 6.10, 9.14 and 12.19 m) lengths with appropriate length pendants.

■ **Boom Connections**

In-line pin connections.

■ **Boom Top Section**

Open throat; 30' (9.14 m) long.

■ **Boompoint Machinery**

Six 21" (0.53 m) root diameter sheaves mounted on lifetime sealed anti-friction bearings for lifting crane applications.

■ **Boom Live Mast**

Supports boomhoist bridle and boom pendants. Required for all boom lengths. May be used as short boom for assembling and disassembling counterweight, outriggers and boom, but is not intended for general crane service. Refer to operator's manual for boom live mast lifting capacities.

Note: The mast may be self-stored either over the back of the machinery house or forward of the boomfoot during transportation. Resulting weight transfer will significantly affect axle loadings (see axle load chart on page 2).

■ **Tubular Jib**

Two-piece basic jib 30' (9.14 m) long; 36" (0.91 m) wide, 30" (0.76 m) deep at connections. Alloy steel tubular chords 2-1/4" (57 mm) outside diameter.

■ **Base Section**

15' (4.57 m) long; mounted to boom headshaft hubs.

■ **Jib Extensions**

Available in 10', 15', 20', 30' and 40' (3.05, 4.57, 6.10, 9.14 and 12.19 m) lengths; maximum jib length permitted - 70' (21.34 m).

■ **Jib Connections**

In-line pin connections.

■ **Jib Tip Section**

15' (4.57 m) long; single peak sheave 21" (0.53 m) root diameter mounted on anti-friction bearings.

■ **Jib Mast**

12' 7-5/8" (6.85 m) high, mounted on jib base section. One deflector sheave, mounted on anti-friction bearings, mounted within mast to guide jib load hoist line. Jib frontstay line and jib backstay line pin at top of jib mast.

GENERAL INFORMATION ONLY